

AN8847SB

Head amplifier IC for CD-ROM drive (for 32 times speed or more)

■ Overview

The AN8847SB is a head amplifier IC for digital servo. It can configure an efficient CD-ROM system in combination with the MN662753, and allows a full-automatic adjustment of tracking balance-gain-offset and focus balance-gain-offset with fewer external parts.

Built-in functions are a variable equalizer, high band RF amp. and AGC which meet CAV playback with 32 times speed or more.

■ Features

- Variable equalizer which meets CAV playback with 32 times speed or more.
 - Wide band RF amp. and AGC ($f_c = 30$ MHz or more (-3 dB))
 - Balance adjustment function built-in
Focus error amp./tracking error amp.
 - CD-RW playback compatible.
- Variable gain
- Focus error amp./tracking error amp.
(to $+16.9$ dB)
- OFTR/BDO detection
 - APC amp.

■ Applications

- CD/CD-ROM drive

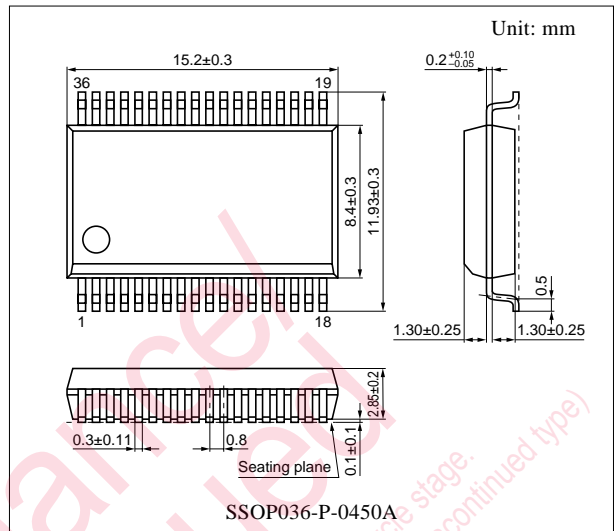

■ Block Diagram

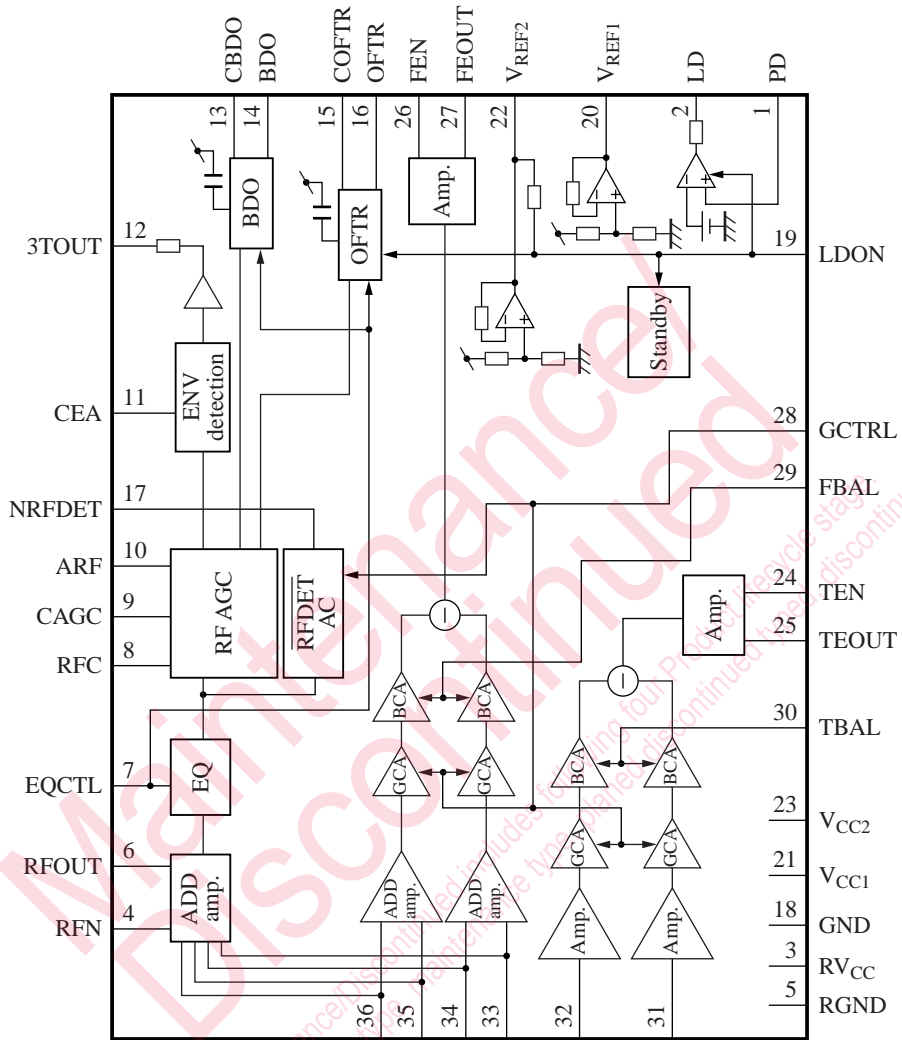

■ Pin Descriptions

Pin No.	Description	Pin No.	Description
1	APC amp. input pin	18	GND pin
2	APC amp. output pin	19	APC & standby control pin
3	Power supply pin (R)	20	V _{REF1} output pin
4	RF addition amp. inverted input pin	21	Power supply pin 1
5	GND pin (R)	22	V _{REF2} output pin
6	RF addition amp. output pin	23	Power supply pin 2
7	EQ characteristics control pin	24	TE amp. inverted input pin
8	Capacitor connection pin for HPF of AGC input	25	TE amp. output pin
9	AGC loop filter connection pin	26	FE amp. inverted input pin
10	AGC output pin	27	FE amp. output pin
11	Capacitor connection pin for HPF amp.	28	GCTL pin
12	3TENV output pin	29	FBAL control pin
13	Capacitor connection pin for RF dark-side envelope detection	30	TBAL control pin
14	BDO output pin	31	Tracking signal input pin 1
15	Capacitor connection pin for RF right-side envelope detection	32	Tracking signal input pin 2
16	OFTR output pin	33	Focus signal input pin 4
17	NRFDET output pin	34	Focus signal input pin 2
		35	Focus signal input pin 3
		36	Focus signal input pin 1

■ Absolute Maximum Ratings

Parameter	Symbol	Rating	Unit
Supply voltage R *1	V _{CCR}	5.8	V
Supply voltage 1 *1	V _{CC1}	5.8	V
Supply voltage 2 *1	V _{CC2}	5.8	V
Supply current R *1	I _{CCR}	97.1	mA
Supply current 1 *1	I _{CC1}	7.4	mA
Supply current 2 *1	I _{CC2}	2.43	mA
Power dissipation *1, *2	P _D	403	mW
Operating ambient temperature *1	T _{opr}	-20 to +75	°C
Storage temperature *1	T _{stg}	-55 to +125	°C

Note) *1: Except for the power dissipation, operating ambient temperature and storage temperature, all ratings are for T_a = 25°C.

*2: The value for the independent package (without a heat sink) at T_a = 75°C.

■ Recommended Operating Range

Parameter	Symbol	Range	Unit
Supply voltage R	V _{CCR}	4.5 to 5.5	V
Supply voltage 1	V _{CC1}	4.5 to 5.5	V
Supply voltage 2	V _{CC2}	3.0 to 5.5	V

■ Electrical Characteristics at $T_a = 25^\circ\text{C}$

Parameter	Symbol	Conditions	Min	Typ	Max	Unit
Current consumption with no load R	I_{TOTALR}	$V_{\text{CC1}} = 5\text{ V}$, $V_{\text{CC2}} = 3.3\text{ V}$ $V_{\text{EQCTL}} = V_{\text{REF2}} + 0.75\text{ V}$	49.4	70.6	91.8	mA
Current consumption with no load 1	I_{TOTAL1}	$V_{\text{CC1}} = 5\text{ V}$, $V_{\text{CC2}} = 3.3\text{ V}$ $V_{\text{EQCTL}} = V_{\text{REF2}} + 0.75\text{ V}$	3.8	5.4	7.0	mA
Current consumption with no load 2	I_{TOTAL2}	$V_{\text{CC1}} = 5\text{ V}$, $V_{\text{CC2}} = 3.3\text{ V}$	1.24	1.77	2.30	mA
V_{REF1} output voltage	V_{REF1}	$V_{\text{CC1}} = 5\text{ V}$, $V_{\text{CC2}} = 3.3\text{ V}$	2.27	2.50	2.73	V
V_{REF2} output voltage	V_{REF2}	$V_{\text{CC1}} = 5\text{ V}$, $V_{\text{CC2}} = 3.3\text{ V}$	1.50	1.65	1.80	V
Focus error amp.						
Focus error amp. output offset voltage	$V_{\text{FO-OF}}$	$V_{\text{CC1}} = 5\text{ V}$, $V_{\text{CC2}} = 3.3\text{ V}$	-90	0	90	mV
Focus error offset balance crosstalk amount	$V_{\text{FO-OFB}}$	$V_{\text{CC1}} = 5\text{ V}$, $V_{\text{CC2}} = 3.3\text{ V}$ $V_{\text{FB}} = V_{\text{REF2}} \pm 0.5\text{ V}$	-150	0	150	mV
Focus error amp. V-V conversion gain	G_{FO}	$V_{\text{CC1}} = 5\text{ V}$, $V_{\text{CC2}} = 3.3\text{ V}$ $V_{\text{GC}} = V_{\text{REF2}} - 0.75\text{ V}$	12.3	14.4	16.5	dB
Focus error amp. V-V conversion relative gain	ΔG_{FO}	$V_{\text{CC1}} = 5\text{ V}$, $V_{\text{CC2}} = 3.3\text{ V}$ $V_{\text{GC}} = V_{\text{REF2}} - 0.75\text{ V}$	-1.5	0	1.5	dB
Focus error amp. balance output 1-H	$B_{\text{FO1-H}}$	$V_{\text{CC1}} = 5\text{ V}$, $V_{\text{CC2}} = 3.3\text{ V}$ $V_{\text{FB}} = V_{\text{REF2}} + 0.5\text{ V}$	1.08	1.35	1.62	—
Focus error amp. balance output 1-L	$B_{\text{FO1-L}}$	$V_{\text{CC1}} = 5\text{ V}$, $V_{\text{CC2}} = 3.3\text{ V}$ $V_{\text{FB}} = V_{\text{REF2}} - 0.5\text{ V}$	0.45	0.65	0.85	—
Focus error amp. balance relative output 2-H	B_{FOH}	$V_{\text{CC1}} = 5\text{ V}$, $V_{\text{CC2}} = 3.3\text{ V}$ $V_{\text{FB}} = V_{\text{REF2}} + 0.5\text{ V}$	4.35	6.35	8.35	dB
Focus error amp. balance relative output 2-L	B_{FOL}	$V_{\text{CC1}} = 5\text{ V}$, $V_{\text{CC2}} = 3.3\text{ V}$ $V_{\text{FB}} = V_{\text{REF2}} - 0.5\text{ V}$	-8.35	-6.35	-4.35	dB
Focus error amp. frequency characteristics	G_{FOF}	$V_{\text{CC1}} = 5\text{ V}$, $V_{\text{CC2}} = 3.3\text{ V}$ $f = 3\text{ kHz}$, 60 kHz	-4.5	-3.0	-1.5	dB
Focus error amp. GCTRL gain ratio $\times 4$	B_{FO4}	$V_{\text{CC1}} = 5\text{ V}$, $V_{\text{CC2}} = 3.3\text{ V}$ $V_{\text{GC}} = V_{\text{REF2}}$	3.3	4.3	5.3	—
Tracking error amp.						
Tracking error amp. output offset voltage	$V_{\text{TR-OF}}$	$V_{\text{CC1}} = 5\text{ V}$, $V_{\text{CC2}} = 3.3\text{ V}$	-60	0	60	mV
Tracking error offset balance crosstalk amount	$V_{\text{TR-OFB}}$	$V_{\text{CC1}} = 5\text{ V}$, $V_{\text{CC2}} = 3.3\text{ V}$ $V_{\text{TB}} = V_{\text{REF2}} \pm 0.5\text{ V}$	-200	0	200	mV
Tracking error amp. V-V conversion gain	G_{TR}	$V_{\text{CC1}} = 5\text{ V}$, $V_{\text{CC2}} = 3.3\text{ V}$ $V_{\text{GC}} = V_{\text{REF2}} - 0.75\text{ V}$	12.2	14.3	16.4	dB
Tracking error amp. V-V conversion relative gain	ΔG_{TR}	$V_{\text{CC1}} = 5\text{ V}$, $V_{\text{CC2}} = 3.3\text{ V}$ $V_{\text{GC}} = V_{\text{REF2}} - 0.75\text{ V}$	-1.5	0	1.5	dB
Tracking error amp. balance output 1-H	$B_{\text{TR1-H}}$	$V_{\text{CC1}} = 5\text{ V}$, $V_{\text{CC2}} = 3.3\text{ V}$ $V_{\text{TB}} = V_{\text{REF2}} + 0.5\text{ V}$	0.45	0.65	0.85	—
Tracking error amp. balance output 1-L	$B_{\text{TR1-L}}$	$V_{\text{CC1}} = 5\text{ V}$, $V_{\text{CC2}} = 3.3\text{ V}$ $V_{\text{TB}} = V_{\text{REF2}} - 0.5\text{ V}$	1.08	1.35	1.62	—

■ Electrical Characteristics at $T_a = 25^\circ\text{C}$ (continue)

Parameter	Symbol	Conditions	Min	Typ	Max	Unit
Tracking error amp. (continued)						
Tracking error amp. balance relative output 2-H	B_{TRH}	$V_{CC1} = 5\text{ V}, V_{CC2} = 3.3\text{ V}$ $V_{TB} = V_{REF2} + 0.5\text{ V}$	-8.35	-6.35	-4.35	dB
Tracking error amp. balance relative output 2-L	B_{TRL}	$V_{CC1} = 5\text{ V}, V_{CC2} = 3.3\text{ V}$ $V_{TB} = V_{REF2} - 0.5\text{ V}$	4.35	6.35	8.35	dB
Tracking error amp. frequency characteristics	G_{TRF}	$V_{CC1} = 5\text{ V}, V_{CC2} = 3.3\text{ V}$ $f = 30\text{ kHz}, 500\text{ kHz}$	-4.5	—	0	dB
Tracking error amp. GCTRL gain ratio $\times 4$	B_{TR4}	$V_{CC1} = 5\text{ V}, V_{CC2} = 3.3\text{ V}$ $V_{GC} = V_{REF2}$	3.3	4.3	5.3	—
RF addition amp.						
RF addition amp. output offset voltage	V_{RAOF}	$V_{CC1} = 5\text{ V}, V_{CC2} = 3.3\text{ V}$	-200	0	200	mV
RF addition amp. addition gain	G_{RAD}	$V_{CC1} = 5\text{ V}, V_{CC2} = 3.3\text{ V}$	-1.5	0	1.5	dB
RF addition amp. addition relative gain 1	ΔG_{RAD1}	$V_{CC1} = 5\text{ V}, V_{CC2} = 3.3\text{ V}$	-1.0	0	1.0	dB
RF addition amp. addition relative gain 2	ΔG_{RAD2}	$V_{CC1} = 5\text{ V}, V_{CC2} = 3.3\text{ V}$	-1.0	0	1.0	dB
RF addition amp. addition relative gain 3	ΔG_{RAD3}	$V_{CC1} = 5\text{ V}, V_{CC2} = 3.3\text{ V}$	-1.0	0	1.0	dB
RF addition amp. full-addition gain	G_{RADA}	$V_{CC1} = 5\text{ V}, V_{CC2} = 3.3\text{ V}$	10.5	12.0	13.5	dB
RF addition amp. full-addition frequency characteristics *	G_{RADDF}	$V_{CC1} = 5\text{ V}, V_{CC2} = 3.3\text{ V}$ $f = 500\text{ kHz}, 40\text{ MHz}$	-2.88	0.12	3.12	dB
Variable EQ characteristics						
EQ characteristics $\times 1-1$ *	G_{EQ1-1}	$f = 10\text{ kHz}, 100\text{ kHz}$ $V_{EQCTL} = V_{REF2} - 0.75\text{ V}$	-1.5	0	1.5	dB
EQ characteristics $\times 1-3$ *	G_{EQ1-3}	$f = 1.4\text{ MHz}$ $V_{EQCTL} = V_{REF2} - 0.75\text{ V}$	2.5	4.0	5.5	dB
EQ characteristics $\times 32-1$ *	G_{EQ32-1}	$f = 2\text{ MHz}$ $V_{EQCTL} = V_{REF2} + 0.75\text{ V}$	-1.5	0	1.5	dB
EQ characteristics $\times 32-3$ *	G_{EQ32-3}	$f = 32\text{ MHz}$ $V_{EQCTL} = V_{REF2} + 0.75\text{ V}$	0.5	2.0	3.5	dB
AGC						
AGC max. gain	G_{MAGC}	$f = 500\text{ kHz}, V_{IN} = 20\text{ mV[p-p]}$	20.0	23.0	26.0	dB
AGC operating gain	G_{AGC}	$f = 500\text{ kHz}, V_{IN} = 500\text{ mV[p-p]}$	3.0	6.0	9.0	dB
AGC compression factor	ΔG_{AGC}	$f = 500\text{ kHz}, V_{IN} = 100\text{ mV[p-p]}$	-1.97	0.53	3.03	dB

Note) *: The values mentioned above are subject to change according to the state of a printed circuit board, a socket, etc.

■ Electrical Characteristics at $T_a = 25^\circ\text{C}$ (continued)

Parameter	Symbol	Conditions	Min	Typ	Max	Unit
NRF detection						
NRF det. detection level	V_{RDA1}	$f = 500 \text{ kHz}, V_{GC} = V_{REF2} - 0.75 \text{ V}$	73	105	137	mV[p-p]
NRF det. high-level output voltage	V_{RDAH}	$f = 500 \text{ kHz}, V_{GC} = V_{REF2} - 0.75 \text{ V}$	4.2	—	—	V
NRF det. low-level output voltage	V_{RDAL}	$f = 500 \text{ kHz}, V_{GC} = V_{REF2} - 0.75 \text{ V}$	—	—	0.8	V
BDO						
CBDO detection current	I_{BDO}	$V_{CC1} = 5 \text{ V}, V_{CC2} = 3.3 \text{ V}$ $V_{EQCTL} = V_{REF2} - 0.5 \text{ V}$	1.07	1.49	1.91	μA
CBDO detection current ratio	B_{IBD4}	$V_{CC1} = 5 \text{ V}, V_{CC2} = 3.3 \text{ V}$ $V_{EQCTL} = V_{REF2}$	4.4	5.4	6.4	—
BDO high-level output voltage	V_{BDOH}	$V_{CC1} = 5 \text{ V}, V_{CC2} = 3.3 \text{ V}$ $f = 5 \text{ kHz}, \text{rectangular wave}$	4.2	—	—	V
BDO low-level output voltage	V_{BDOL}	$V_{CC1} = 5 \text{ V}, V_{CC2} = 3.3 \text{ V}$ $f = 5 \text{ kHz}, \text{sine wave}$	—	—	0.8	V
OFTR						
COFTR detection current	I_{OFTR}	$V_{CC1} = 5 \text{ V}, V_{CC2} = 3.3 \text{ V}$ $V_{LDON} = V_{REF2} - 0.5 \text{ V}$	1.07	1.49	1.91	μA
COFTR detection current ratio	B_{IOFTR4}	$V_{CC1} = 5 \text{ V}, V_{CC2} = 3.3 \text{ V}$ $V_{LDON} = V_{REF2}$	3.1	3.9	4.7	—
OFTR high-level output voltage	V_{OFTRH}	$V_{CC1} = 5 \text{ V}, V_{CC2} = 3.3 \text{ V}$ $f = 5 \text{ kHz}, \text{rectangular wave}$	4.2	—	—	V
OFTR low-level output voltage	V_{OFTRL}	$V_{CC1} = 5 \text{ V}, V_{CC2} = 3.3 \text{ V}$ $f = 5 \text{ kHz}, \text{rectangular wave}$	—	—	0.8	V
OFTR sensitivity	V_{OFT_S}	$f = 470 \text{ kHz}, \text{sine wave}$ $V_{LDON} = V_{REF2} + 0.75 \text{ V}$	0	—	1.2	V
3TENV						
CEA to ENV transfer characteristics	$G_{CEA-ENV}$	$V_{CC1} = 5 \text{ V}, V_{CC2} = 3.3 \text{ V}$	25.0	28.0	31.0	dB
CEA input impedance	Z_{CEA}	$V_{CC1} = 5 \text{ V}, V_{CC2} = 3.3 \text{ V}$	6.5	8.5	10.5	k Ω
ENV amp. output impedance	Z_{ENV}	$V_{CC1} = 5 \text{ V}, V_{CC2} = 3.3 \text{ V}$	6.0	8.0	10.0	k Ω
ENV amp. offset voltage	V_{ENVOF}	$V_{CC1} = 5 \text{ V}, V_{CC2} = 3.3 \text{ V}$	-120	0	120	mV
ENV amp. operation	V_{ENV}	$V_{CC1} = 5 \text{ V}, V_{CC2} = 3.3 \text{ V}$ $f = 800 \text{ kHz}, \text{AM modulation}$	210	420	630	mV[p-p]
LD APC						
LD operating reference voltage	V_{LD}	$V_{CC1} = 5 \text{ V}, V_{CC2} = 3.3 \text{ V}$	139	170	201	mV
LDON operating voltage	V_{LDON}	$V_{CC1} = 5 \text{ V}, V_{CC2} = 3.3 \text{ V}$	—	—	-0.35	V
Standby						
Current consumption at no load in a standby mode	I_{STBY}	$V_{CC1} = 5 \text{ V}, V_{CC2} = 3.3 \text{ V}$ $V_{LDON} = V_{REF2} - 0.75 \text{ V}$	3.61	5.16	6.71	mA

■ Application Circuit Example

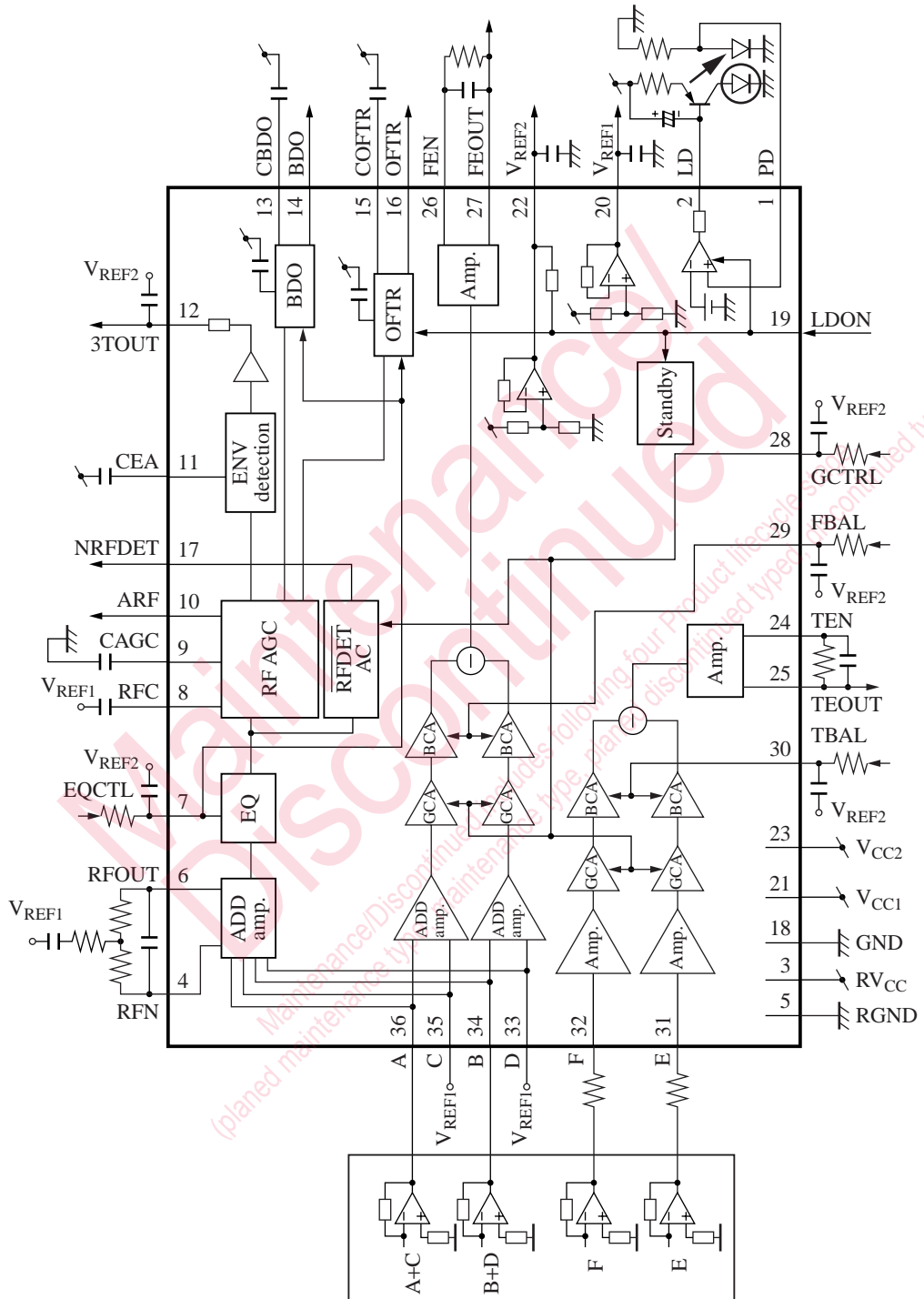

Request for your special attention and precautions in using the technical information and semiconductors described in this book

- (1) If any of the products or technical information described in this book is to be exported or provided to non-residents, the laws and regulations of the exporting country, especially, those with regard to security export control, must be observed.
- (2) The technical information described in this book is intended only to show the main characteristics and application circuit examples of the products, and no license is granted under any intellectual property right or other right owned by our company or any other company. Therefore, no responsibility is assumed by our company as to the infringement upon any such right owned by any other company which may arise as a result of the use of technical information described in this book.
- (3) The products described in this book are intended to be used for standard applications or general electronic equipment (such as office equipment, communications equipment, measuring instruments and household appliances).
Consult our sales staff in advance for information on the following applications:
 - Special applications (such as for airplanes, aerospace, automobiles, traffic control equipment, combustion equipment, life support systems and safety devices) in which exceptional quality and reliability are required, or if the failure or malfunction of the products may directly jeopardize life or harm the human body.
 - Any applications other than the standard applications intended.
- (4) The products and product specifications described in this book are subject to change without notice for modification and/or improvement. At the final stage of your design, purchasing, or use of the products, therefore, ask for the most up-to-date Product Standards in advance to make sure that the latest specifications satisfy your requirements.
- (5) When designing your equipment, comply with the range of absolute maximum rating and the guaranteed operating conditions (operating power supply voltage and operating environment etc.). Especially, please be careful not to exceed the range of absolute maximum rating on the transient state, such as power-on, power-off and mode-switching. Otherwise, we will not be liable for any defect which may arise later in your equipment.
 - Even when the products are used within the guaranteed values, take into the consideration of incidence of break down and failure mode, possible to occur to semiconductor products. Measures on the systems such as redundant design, arresting the spread of fire or preventing glitch are recommended in order to prevent physical injury, fire, social damages, for example, by using the products.
- (6) Comply with the instructions for use in order to prevent breakdown and characteristics change due to external factors (ESD, EOS, thermal stress and mechanical stress) at the time of handling, mounting or at customer's process. When using products for which damp-proof packing is required, satisfy the conditions, such as shelf life and the elapsed time since first opening the packages.
- (7) This book may be not reprinted or reproduced whether wholly or partially, without the prior written permission of Matsushita Electric Industrial Co., Ltd.