

SN5491A, SN54LS91, SN7491A, SN74LS91 8-BIT SHIFT REGISTERS

MARCH 1974 — REVISED MARCH 1988

- For applications in:
Digital Computer Systems
Data-Handling Systems
Control Systems

TYPE	TYPICAL MAXIMUM CLOCK FREQUENCY	TYPICAL POWER DISSIPATION
'91A	18 MHz	175 mW
'LS91	18 MHz	60 mW

SN5491A, SN54LS91 . . . J PACKAGE
 SN7491A . . . N PACKAGE
 SN74LS91 . . . D OR N PACKAGE
 (TOP VIEW)

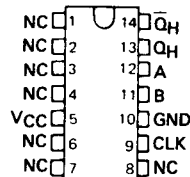

SN5491A, SN54LS91 . . . W PACKAGE
 (TOP VIEW)

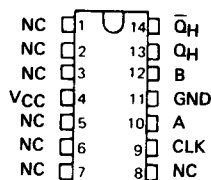

NC - No internal connection

description

These monolithic serial-in, serial-out, 8-bit shift registers utilize transistor-transistor logic (TTL) circuits and are composed of eight R-S master-slave flip-flops, input gating, and a clock driver. Single-rail data and input control are gated through inputs A and B and an internal inverter to form the complementary inputs to the first bit of the shift register. Drive for the internal common clock line is provided by an inverting clock driver. This clock pulse inverter/driver causes these circuits to shift information one bit on the positive edge of an input clock pulse.

FUNCTION TABLE

INPUTS AT t_n		OUTPUTS AT $t_n + 8$	
A	B	Q_H	\bar{Q}_H
H	H	H	L
L	X	L	H
X	L	L	H

t_n = Reference bit time,
clock low

$t_n + 8$ = Bit time after 8
low-to-high
clock transitions.

logic symbol†

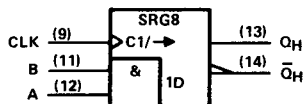

† This symbol is in accordance with ANSI/IEEE Std 91-1984 and IEC Publication 617-12.

schematics of inputs and outputs

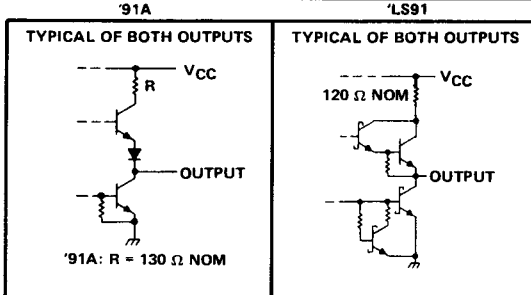
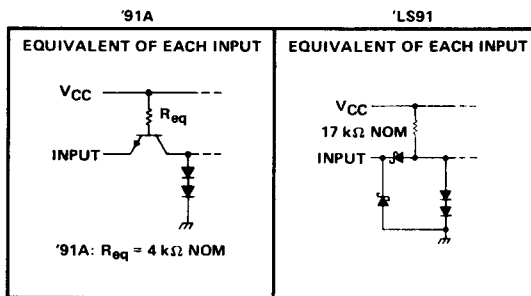

2
TTL Devices

PRODUCTION DATA documents contain information current as of publication date. Products conform to specifications per the terms of Texas Instruments standard warranty. Production processing does not necessarily include testing of all parameters.



SN5491A, SN7491A 8-BIT SHIFT REGISTERS

logic diagram (positive logic)

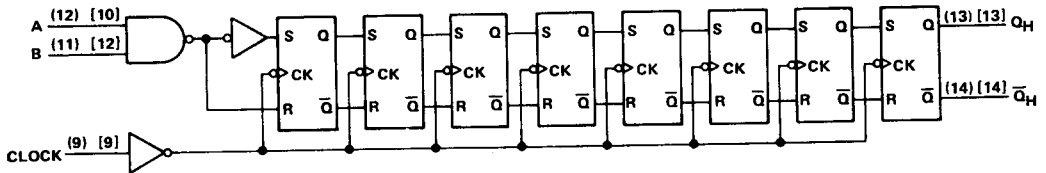

Pin numbers shown in () are for the D, J or N packages and pin numbers shown in [] are for the W package.

absolute maximum ratings over operating free-air temperature range (unless otherwise noted)

Supply voltage, V_{CC} (see Note 1)	7 V
Input voltage (see Note 2)	5.5 V
Operating free-air temperature range: SN5491A	-55°C to 125°C
SN7491A	0°C to 70°C
Storage temperature range	-65°C to 150°C

- NOTES: 1. Voltage values are with respect to network ground terminal.
2. Input signals must be zero or positive with respect to network ground terminal.

recommended operating conditions

	SN5491A			SN7491A			UNIT
	MIN	NOM	MAX	MIN	NOM	MAX	
Supply voltage, V_{CC}	4.5	5	5.5	4.75	5	5.25	V
High-level output current, I_{OH}	-400			-400			μ A
Low-level output current, I_{OL}	16			16			mA
Width of clock input pulse, t_w	25			25			ns
Setup time, t_{SU} (see Figure 1)	25			25			ns
Hold time, t_H (see Figure 1)	0			0			ns
Operating free-air temperature, T_A	-55	125		0	70		°C

electrical characteristics over recommended operating free-air temperature range (unless otherwise noted)

PARAMETER	TEST CONDITIONS†	SN5491A			SN7491A			UNIT
		MIN	NOM	MAX	MIN	NOM	MAX	
V_{IH} High-level input voltage		2			2			V
V_{IL} Low-level input voltage				0.8			0.8	V
V_{OH} High-level output voltage	$V_{CC} = \text{MIN}$, $V_{IH} = 2 \text{ V}$, $V_{IL} = 0.8 \text{ V}$, $I_{OH} = -400 \mu\text{A}$	2.4	3.5		2.4	3.5		V
V_{OL} Low-level output voltage	$V_{CC} = \text{MIN}$, $V_{IH} = 2 \text{ V}$, $V_{IL} = 0.8 \text{ V}$, $I_{OL} = 16 \text{ mA}$		0.2	0.4		0.2	0.4	V
I_I Input current at maximum input voltage	$V_{CC} = \text{MAX}$, $V_I = 5.5 \text{ V}$			1			1	mA
I_{IH} High-level input current	$V_{CC} = \text{MAX}$, $V_I = 2.4 \text{ V}$			40			40	μ A
I_{IL} Low-level input current	$V_{CC} = \text{MAX}$, $V_I = 0.4 \text{ V}$			-1.6			-1.6	mA
I_{OS} Short-circuit output current‡	$V_{CC} = \text{MAX}$	-20		-57	-18		-57	mA
I_{CC} Supply current	$V_{CC} = \text{MAX}$, See Note 3		35	50		35	58	mA

† For conditions shown as MIN or MAX, use the appropriate value specified under recommended operating conditions.

‡ All typical values are at $V_{CC} = 5 \text{ V}$, $T_A = 25^\circ \text{C}$.

§ Not more than one output should be shorted at a time.

NOTE 3: I_{CC} is measured after the eighth clock pulse with the output open and A and B inputs grounded.

switching characteristics, $V_{CC} = 5 \text{ V}$, $T_A = 25^\circ \text{C}$

PARAMETER	TEST CONDITIONS	MIN	TYP	MAX	UNIT
f_{max} Maximum clock frequency	$C_L = 15 \text{ pF}$,	10	18		MHz
t_{PLH} Propagation delay time, low-to-high-level output	$R_L = 400 \Omega$,		24	40	ns
t_{PHL} Propagation delay time, high-to-low-level output	See Figure 1		27	40	ns

2

TTL Devices

SN54LS91, SN74LS91 8-BIT SHIFT REGISTERS

absolute maximum ratings over operating free-air temperature range (unless otherwise noted)

Supply voltage, V_{CC} (see Note 1)	7 V
Input voltage	7 V
Operating free-air temperature range: SN54LS91	-55°C to 125°C
SN74LS91	0°C to 70°C
Storage temperature range	-65°C to 150°C

NOTES: 1. Voltage values are with respect to network ground terminal.

recommended operating conditions

	SN54LS91			SN74LS91			UNIT
	MIN	NOM	MAX	MIN	NOM	MAX	
Supply voltage, V_{CC}	4.5	5	5.5	4.75	5	5.25	V
High-level output current, I_{OH}			-400			-400	μ A
Low-level output current, I_{OL}			4			8	mA
Width of clock input pulse, t_W	25			25			ns
Setup time, t_{SU} (see Figure 1)	25			25			ns
Hold time, t_H (see Figure 1)	0			0			ns
Operating free-air temperature, T_A	-55		125	0		70	C

electrical characteristics over recommended operating free-air temperature range (unless otherwise noted)

PARAMETER	TEST CONDITIONS [†]	SN54LS91			SN74LS91			UNIT
		MIN	TYP [‡]	MAX	MIN	TYP [‡]	MAX	
V_{IH} High-level input voltage		2			2			V
V_{IL} Low-level input voltage				0.7			0.8	V
V_{IK} Input clamp voltage	$V_{CC} = \text{MIN}, I_I = -18 \text{ mA}$			-1.5			-1.5	V
V_{OH} High-level output voltage	$V_{CC} = \text{MIN}, V_{IH} = 2 \text{ V}, V_{IL} = V_{IL \text{ max}}, I_{OH} = -400 \mu\text{A}$	2.5	3.5		2.7	3.5		V
V_{OL} Low-level output voltage	$V_{CC} = \text{MIN}, V_{IH} = 2 \text{ V}, V_{IL} = V_{IL \text{ max}}$	$I_{OL} = 4 \text{ mA}$		0.25	0.4	0.25	0.4	V
		$I_{OL} = 8 \text{ mA}$				0.35	0.5	
I_I Input current at maximum input voltage	$V_{CC} = \text{MAX}, V_I = 7 \text{ V}$			0.1			0.1	mA
I_{IH} High-level input current	$V_{CC} = \text{MAX}, V_I = 2.7 \text{ V}$			20			20	μ A
I_{IL} Low-level input current	$V_{CC} = \text{MAX}, V_I = 0.4 \text{ V}$			-0.4			-0.4	mA
I_{OS} Short-circuit output current [§]	$V_{CC} = \text{MAX}$	-20		-100	-20		-100	mA
I_{CC} Supply current	$V_{CC} = \text{MAX},$ See Note 3		12	20		12	20	mA

[†] For conditions shown as MIN or MAX, use the appropriate value specified under recommended operating conditions.

[‡] All typical values are at $V_{CC} = 5 \text{ V}, T_A = 25^\circ \text{C}$.

[§] Not more than one output should be shorted at a time, and duration of the short-circuit should not exceed one second.

NOTE 3: I_{CC} is measured after the eighth clock pulse with the output open and A and B inputs grounded.

switching characteristics, $V_{CC} = 5 \text{ V}, T_A = 25^\circ \text{C}$

PARAMETER	TEST CONDITIONS	MIN	TYP	MAX	UNIT
f_{max} Maximum clock frequency	$C_L = 15 \text{ pF},$	10	18		MHz
t_{PLH} Propagation delay time, low-to-high-level output	$R_L = 2 \text{ k}\Omega,$		24	40	ns
t_{PHL} Propagation delay time, high-to-low-level output	See Figure 1		27	40	ns

2

TTL Devices

SN5491A, SN54LS91, SN7491A, SN74LS91 8-BIT SHIFT REGISTERS

PARAMETER MEASUREMENT INFORMATION

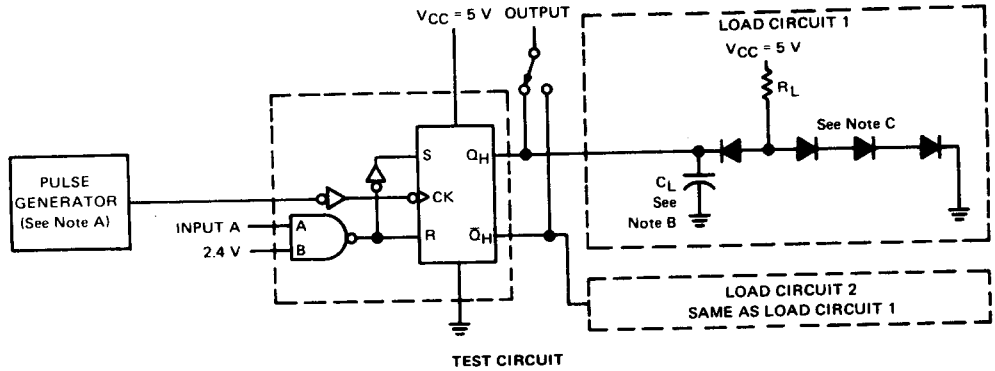

2

TTL Devices

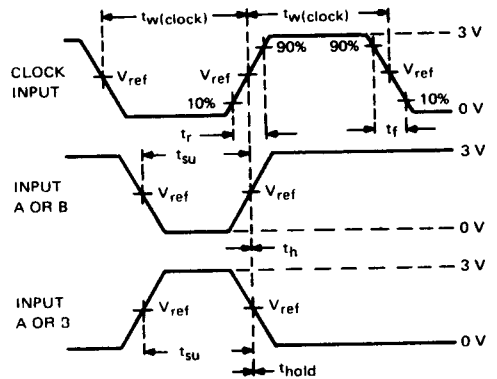
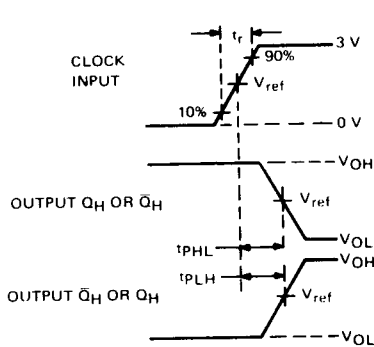
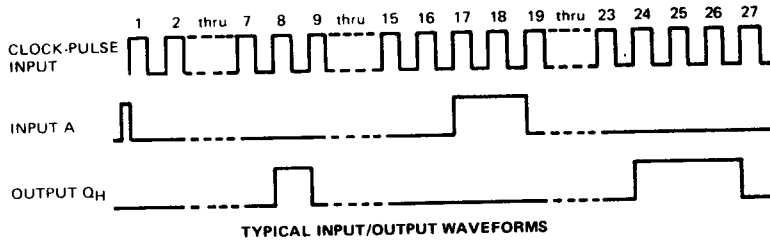

PROPAGATION DELAY TIMES VOLTAGE WAVEFORMS

SWITCHING TIMES VOLTAGE WAVEFORMS

- NOTES: A. The generator has the following characteristics: $t_w(\text{clock}) = 500 \text{ ns}$, $\text{PRR} \leq 1 \text{ MHz}$, $Z_{\text{out}} \approx 50 \Omega$. For SN5491A/SN7491A, $t_r \leq 10 \text{ ns}$ and $t_f \leq 10 \text{ ns}$; for SN54LS91, $t_r = 15 \text{ ns}$, and $t_f = 6 \text{ ns}$.
 B. C_L includes probe and jig capacitance.
 C. All diodes are 1N3064 or equivalent.
 D. For SN5491A/SN7491A, $V_{\text{ref}} = 1.5 \text{ V}$; for SN54LS91/SN74LS91, $V_{\text{ref}} = 1.3 \text{ V}$.

FIGURE 1—SWITCHING TIMES