



Micro Commercial Components

Micro Commercial Components
 20736 Marilla Street Chatsworth
 CA 91311
 Phone: (818) 701-4933
 Fax: (818) 701-4939

2SC4115S
2SC4115S-Q
2SC4115S-R
2SC4115S-S

Features

- Power dissipation: $P_{CM} = 0.3W(T_{amb}=25^{\circ}C)$
- Collector current: $I_{CM} = 3A$
- Collector-base voltage: $V_{(BR)CBO} = 40V$
- Operating and storage junction temperature range
 $T_J, T_{stg}: -55^{\circ}C$ to $+150^{\circ}C$

Electrical Characteristics @ 25°C Unless Otherwise Specified

Symbol	Parameter	Min	Typ	Max	Unit
V_{CEO}	Collector-Emitter Voltage ($I_C = -50 \mu A, I_E = 0$)	20	---	---	V
V_{CBO}	Collector-Base Voltage ($I_C = -1 \mu A, I_B = 0$)	40	---	---	V
V_{EBO}	Emitter-Base Voltage ($I_E = -50 \mu A, I_C = 0$)	6.0	---	---	V
I_{CBO}	Collector cut-off Current ($V_{CB} = -20V, I_E = 0$)	---	---	0.1	μA
I_{EBO}	Emitter cut-off Current ($V_{EB} = -5V, I_C = 0$)	---	---	0.1	μA
h_{FE}	DC current gain ($V_{CE} = -2V, I_C = -0.1A$)	120	---	560	---
$V_{CE(sat)}$	Collector-Emitter Saturation Voltage ($I_C = -2A, I_B = -0.1A$)	---	---	0.5	V
f_T	Transition Frequency ($V_{CE} = 2.0V_{dc}, I_C = 0.5A_{dc}$)	200	---	---	MHz

Measured Using Pulse Current

CLASSIFICATION OF h_{FE}

Rank	Q	R	S
Range	120-270	180-390	270-560
Marking	4115Q	4115R	4115S

NPN
Plastic-Encapsulate
Transistors

TO-92S

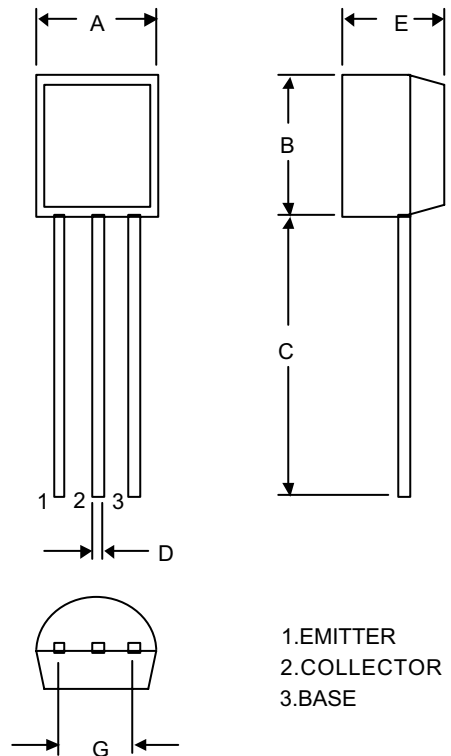

DIM	INCHES		MM		NOTE
	MIN	MAX	MIN	MAX	
A	.16	---	4.00	---	
B	.12	---	3.00	---	
C	.59	---	15.00	---	
D	.02	---	0.45	---	
E	.08	---	2.00	---	
G	.20	---	5.00	---	