

### FEATURES

- InGaP HBT Technology
- -47 dBc ACPR @  $\pm 10$  MHz, +27 dBm
- 29 dB Gain
- High Efficiency
- Low Transistor Junction Temperature
- Matched for a 50  $\Omega$  System
- Low Profile Miniature Surface Mount Package; RoHS Compliant
- Multi-Carrier Capability

### APPLICATIONS

- LTE, WCDMA, and HSDPA Air Interfaces
- Picocell, Femtocell, Home Nodes
- Customer Premises Equipment (CPE)

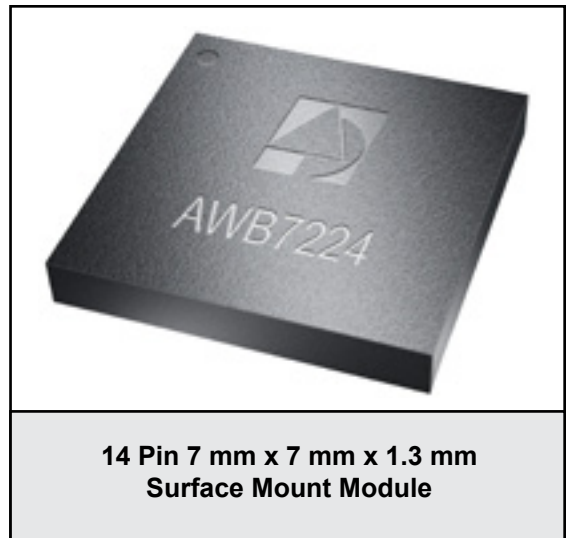

### PRODUCT DESCRIPTION

The AWB7224 is a fully matched, Multi-Chip-Module (MCM) designed for picocell, femtocell, and customer premises equipment (CPE) applications. Consisting of two parallel path high linearity, high efficiency power amplifiers, the device meets the extremely demanding needs of small cell infrastructure architectures. Designed for LTE, WCDMA and HSDPA air interfaces operating in the 728 MHz to 768 MHz bands, the AWB7224 delivers up to +27 dBm of LTE (E-TM1.1)

power through an external 90-degree hybrid coupler, with an ACPR of -47 dBc. The device operates from a convenient +4.5 V supply and provides 29 dB of RF gain. The AWB7224 is manufactured using an advanced InGaP HBT MMIC technology offering state-of-the-art reliability, temperature stability, and ruggedness. Its 7 mm x 7 mm x 1.3 mm surface mount package incorporates RF matching networks optimized for output power, efficiency, and linearity in a 50  $\Omega$  system.

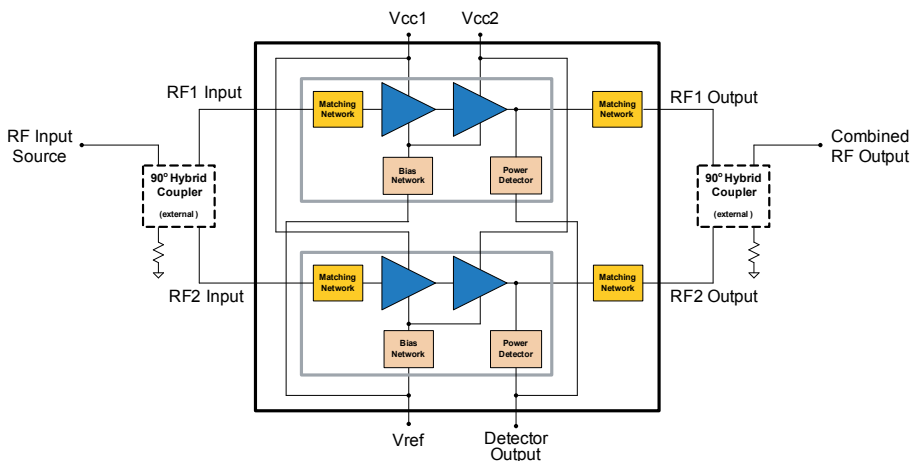

**Figure 1: Block Diagram**

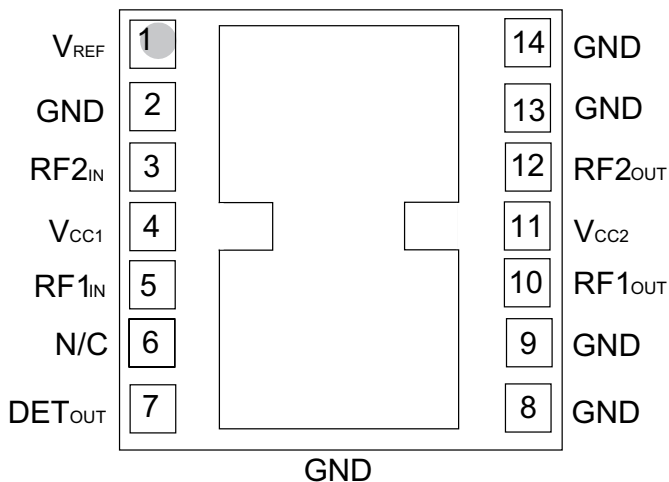

Figure 2: Pinout (X-ray Top View)

Table 1: Pin Description

PIN	NAME	DESCRIPTION
1	V <sub>REF</sub>	Reference Voltage
2	GND	Ground
3	RF2 <sub>IN</sub>	RF2 Input
4	V <sub>CC1</sub>	Supply Voltage
5	RF1 <sub>IN</sub>	RF1 Input
6	N/C	No Connection
7	DET <sub>OUT</sub>	Detector Output
8	GND	Ground
9	GND	Ground
10	RF1 <sub>OUT</sub>	RF1 Output
11	V <sub>CC2</sub>	Supply Voltage
12	RF2 <sub>OUT</sub>	RF2 Output
13	GND	Ground
14	GND	Ground

## ELECTRICAL CHARACTERISTICS

Table 2: Absolute Minimum and Maximum Ratings

PARAMETER	MIN	MAX	UNIT
Supply Voltage ( $V_{CC}$ )	0	+5	V
Reference Voltage ( $V_{REF}$ )	0	+3.5	V
RF Output Power ( $P_{OUT}$ )	-	+30 <sup>(1)</sup>	dBm
Storage Temperature ( $T_{STG}$ )	-40	+150	°C

Stresses in excess of the absolute ratings may cause permanent damage. Functional operation is not implied under these conditions. Exposure to absolute ratings for extended periods of time may adversely affect reliability.

Notes:

(1) At output of external 90° hybrid coupler.

Table 3: Operating Ranges

PARAMETER	MIN	TYP	MAX	UNIT	COMMENTS
Operating Frequency (f)	728	-	768	MHz	
Supply Voltage ( $V_{CC}$ )	+3.6	+4.5	+4.65	V	
Reference Voltage ( $V_{REF}$ )	+2.75 0	+2.85 -	+2.95 +0.5	V	PA "on" PA "shut down"
RF Output Power ( $P_{OUT}$ )	-	+27	-	dBm	Using external 90° hybrid couplers
Case Temperature ( $T_C$ )	-40	-	+85	°C	

The device may be operated safely over these conditions; however, parametric performance is guaranteed only over the conditions defined in the electrical specifications.

**Table 4: Electrical Specifications**  
**(T<sub>c</sub> = +25 °C, V<sub>CC</sub> = +4.5 V, V<sub>REF</sub> = +2.85 V, 50 Ω system)**

PARAMETER	MIN	TYP	MAX	UNIT	COMMENTS
Gain <sup>(2)</sup>	-	29	-	dB	728 - 768 MHz
ACPR <sup>(1), (2), (3)</sup> @ 10 MHz @ 20 MHz	- -	-47 -57	- -	dBc	
Power-Added Efficiency <sup>(1), (2), (3)</sup>	-	13	-	%	
Thermal Resistance	-	TBD	-	°C/W	Junction to Case
Quiescent Current (I <sub>q</sub> )	-	265	-	mA	
Reference Current	-	10	-	mA	through V <sub>REF</sub> pin
Leakage Current	-	3	10	μA	V <sub>CC</sub> = +5 V, V <sub>REF</sub> = 0 V
Harmonics <sup>(2)</sup> 2fo 3fo, 4fo	- -	-50 -60	- -	dBc	
Input Return Loss <sup>(2)</sup>	-	20	-	dB	
Output Return Loss <sup>(2)</sup>	-	20	-	dB	
P1dB	-	TBD	-	dBm	CW tone
Spurious Output Level <sup>(2)</sup> (all spurious outputs)	-	-	-60	dBc	P <sub>OUT</sub> ≤ +27 dBm In-band load VSWR < 5:1 Out-of-band load VSWR < 10:1 Applies over all voltage and temperature operating ranges
Load mismatch stress with no permanent degradation or failure <sup>(2)</sup>	8:1	-	-	VSWR	V <sub>CC</sub> = +4.5 V, P <sub>OUT</sub> = + 27 dBm Applies over full operating temperature range

## Notes:

(1) ACPR and Efficiency measured at 748 MHz.

(2) P<sub>OUT</sub> = +27 dBm, using specified external 90° hybrid couplers.

(3) LTE E-TM1.1 (10 MHz).

### APPLICATION INFORMATION

To ensure proper performance, refer to all related Application Notes on the ANADIGICS web site: <http://www.anadigics.com>

#### Shutdown Mode

The power amplifier may be placed in a shutdown mode by applying logic low levels (see Operating Ranges table) to the  $V_{REF}$  voltage.

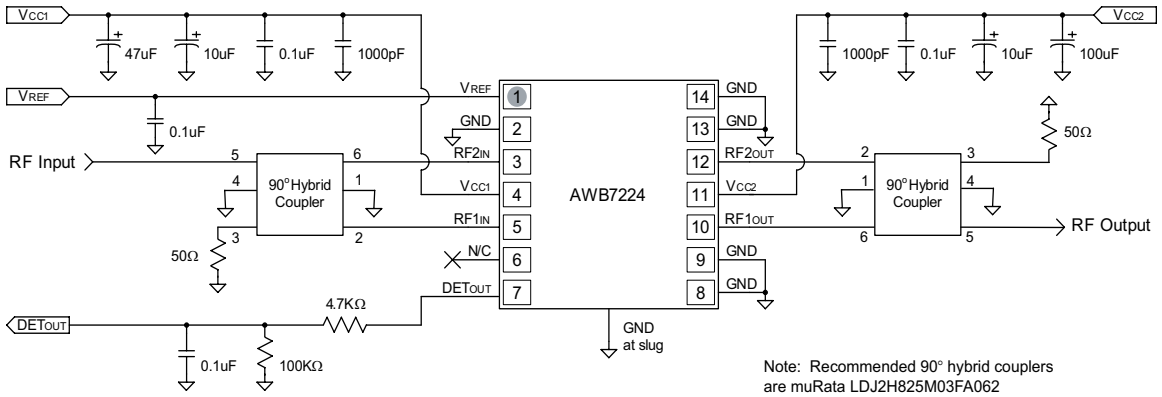
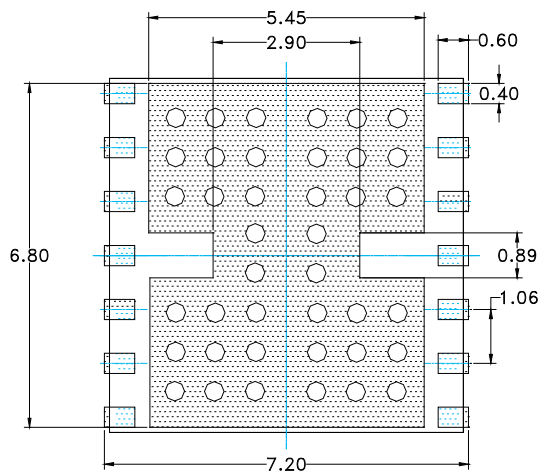

Figure 3: Application Circuit Schematic



PCB METAL  
TOP (X-RAY) VIEW

ONLY PACKAGE I/O's AND  
GROUND REQUIREMENTS  
SHOWN.

NOTES:

- (1) UNLESS SPECIFIED DIMENSIONS ARE SYMMETRICAL ABOUT CENTER LINES SHOWN.
- (2) DIMENSIONS IN MILLIMETERS.
- (3) VIAS SHOWN IN PCB METAL VIEW ARE FOR REFERENCE ONLY. NUMBER & SIZE OF THERMAL VIAS REQUIRED DEPENDENT ON HEAT DISSIPATION REQUIREMENT AND THE PCB PROCESS CAPABILITY.

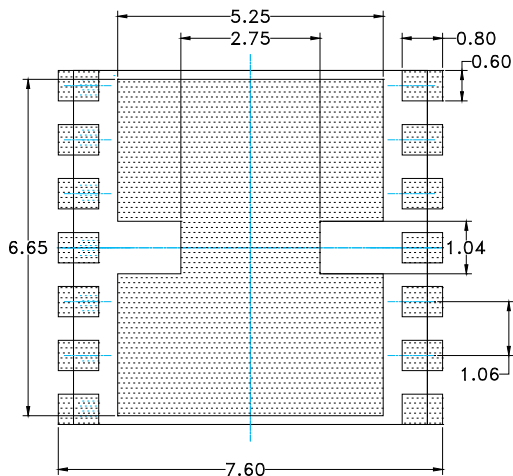

PCB SOLDER MASK  
TOP (X-RAY) VIEW

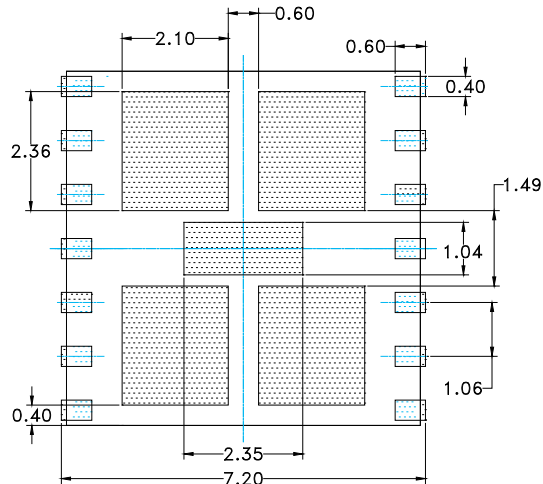

STENCIL APERTURE  
TOP (X-RAY) VIEW

Figure 4: PCB Footprint

PACKAGE OUTLINE

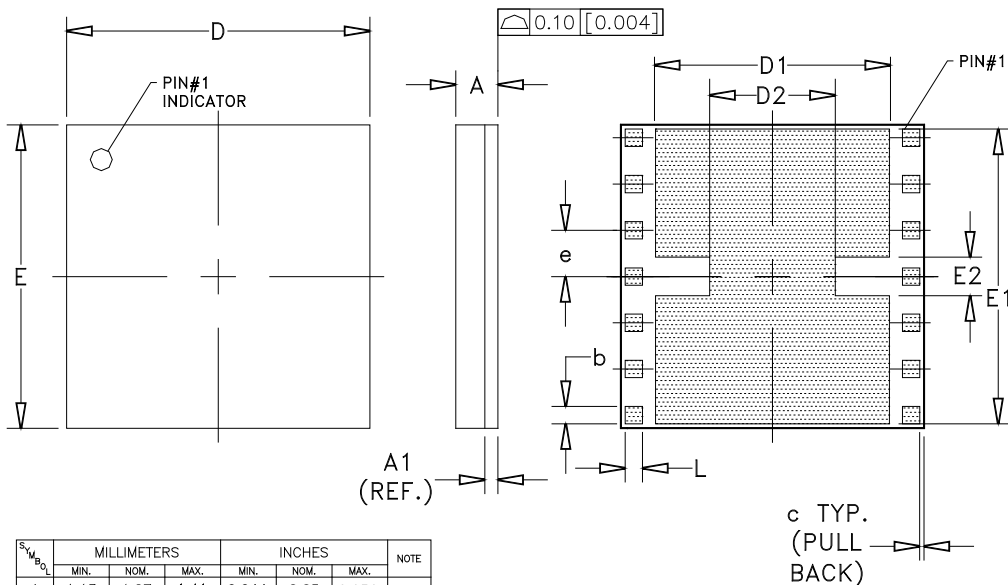

SYMBOL	MILLIMETERS			INCHES			NOTE
	MIN.	NOM.	MAX.	MIN.	NOM.	MAX.	
A	1.13	1.27	1.41	0.044	0.05	0.056	—
A1	0.27 (REF)			0.011 (REF)			—
b	0.387	0.400	0.413	0.0152	0.0157	0.0162	14X
c	—	0.10	—	—	0.004	—	—
D	6.88	7.00	7.12	0.270	0.275	0.280	—
D1	5.30	5.45	5.60	0.208	0.214	0.220	—
D2	2.87	2.90	2.93	0.113	0.114	0.115	—
E	6.88	7.00	7.12	0.270	0.275	0.280	—
E1	6.78	6.80	6.82	0.266	0.267	0.268	—
E2	0.86	0.89	0.92	0.034	0.035	0.036	—
e	1.07			0.0421			6X
L	0.387	0.400	0.413	0.0152	0.0157	0.0162	14X

NOTES:

1. CONTROLLING DIMENSIONS: MILLIMETERS
2. UNLESS SPECIFIED TOLERANCE=±0.076[0.003].
3. PADS (INCLUDING CENTER) SHOWN UNIFORM SIZE FOR REFERENCE ONLY. ACTUAL PAD SIZE AND LOCATION WILL VARY WITHIN MIN. AND MAX. DIMENSIONS ACCORDING TO SPECIFIC LAMINATE DESIGN.

Figure 5: Package Outline - 14 Pin 7 mm x 7 mm x 1.3 mm Surface Mount Module

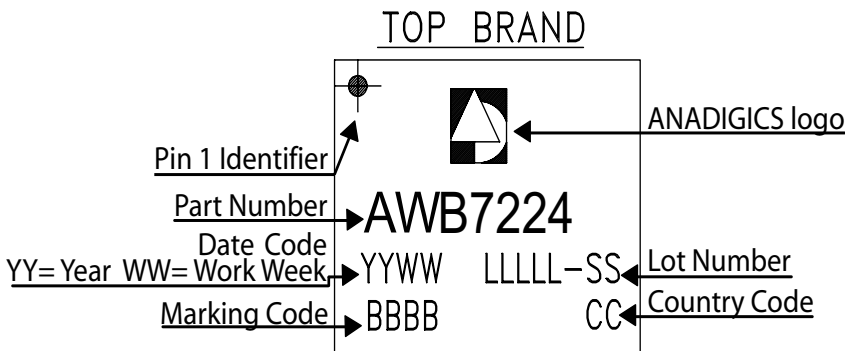

Figure 6: Branding Specification

COMPONENT PACKAGING

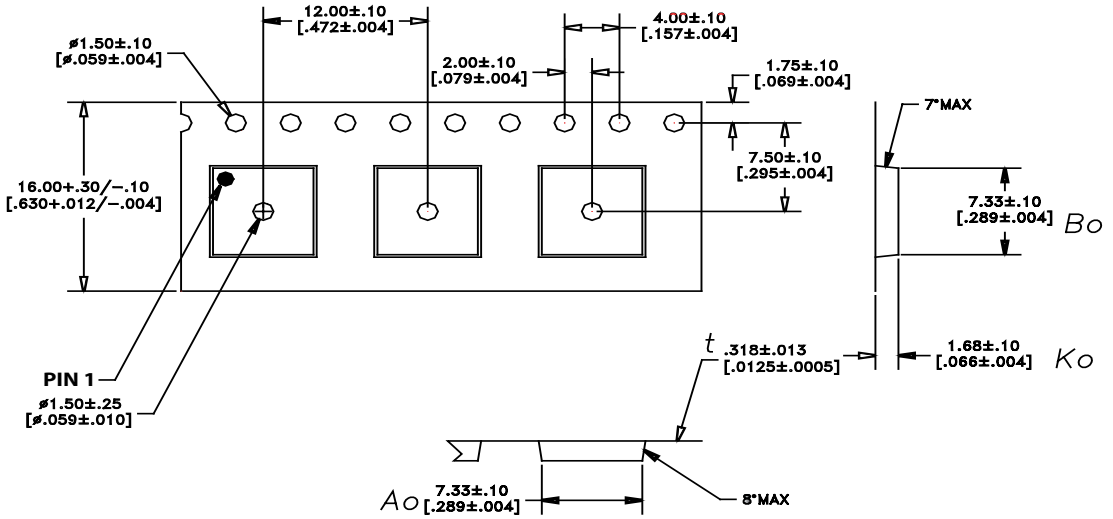

Figure 7: Tape & Reel Packaging

Table 5: Tape & Reel Dimensions

PACKAGE TYPE	TAPE WIDTH	POCKET PITCH	REEL CAPACITY	MAX REEL DIA
7 mm x 7 mm x 1.3 mm	16 mm	12 mm	2500	13"



**ANADIGICS, Inc.**

141 Mount Bethel Road

Warren, New Jersey 07059, U.S.A.

Tel: +1 (908) 668-5000

Fax: +1 (908) 668-5132

URL: <http://www.anadigics.com>

**IMPORTANT NOTICE**

ANADIGICS, Inc. reserves the right to make changes to its products or to discontinue any product at any time without notice. The product specifications contained in Advanced Product Information sheets and Preliminary Data Sheets are subject to change prior to a product's formal introduction. Information in Data Sheets have been carefully checked and are assumed to be reliable; however, ANADIGICS assumes no responsibilities for inaccuracies. ANADIGICS strongly urges customers to verify that the information they are using is current before placing orders.

**WARNING**

ANADIGICS products are not intended for use in life support appliances, devices or systems. Use of an ANADIGICS product in any such application without written consent is prohibited.