



**HL02U SERIES**  
**2 WATT**  
**UNREGULATED**

**DC/DC CONVERTERS**

**24 PIN DUAL-IN-LINE-PACKAGE AND SMD**

**FEATURES**

- LOW COST
- INTERNAL FILTERING
- SURFACE MOUNT CONSTRUCTION
- TEMPERATURE RANGE:  
-25°C TO +70°C
- HIGH EFFICIENCY
- LOW OUTPUT NOISE
- NON-CONDUCTIVE CASE

**DESCRIPTION**

The HL02U Series offers an extensive selection of input and output voltages to choose from. These miniature, unregulated DC/DC converters come in 24-pin DIP and SMD packages. This small size is possible through the use of surface mount manufacturing technologies.

The HL02U Series utilizes a 110KHz push-pull oscillator in the input stage with internal filtering to reduce the output noise and maintaining good efficiency.

The use of surface mount construction and automated manufacturing processes increase consistency and reliability while reducing overall cost.

**ABSOLUTE MAXIMUM RATINGS**

Internal Power Dissipation.....	0.90W
Short Circuit Duration.....	30 Sec
Lead Temperature (soldering, 10 seconds max).....	+300°C *

\* Note: Refer to Reflow Profile for SMD Models.

**ORDERING INFORMATION**

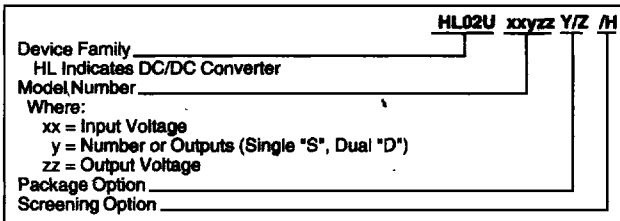

# ELECTRICAL SPECIFICATIONS

Specifications typical at  $T_A = +25^\circ\text{C}$ , nominal input voltage, rated output current unless otherwise specified.

MODEL	NOMINAL INPUT VOLTAGE (VDC)	RATED OUTPUT VOLTAGE (VDC)	RATED OUTPUT CURRENT (mA)	INPUT CURRENT		EFFICIENCY (%)
				NO LOAD (mA)	RATED LOAD (mA)	
HL02U05S05	5	5	400	40	540	74
HL02U05S12	5	12	167	40	480	83
HL02U05S15	5	15	133	40	480	83
HL02U12S05	12	5	400	30	230	72
HL02U12S12	12	12	167	30	210	79
HL02U12S15	12	15	133	30	210	79
HL02U15S05	15	5	400	30	190	70
HL02U15S12	15	12	167	30	170	78
HL02U15S15	15	15	133	30	170	78
HL02U24S05	24	5	400	20	125	72
HL02U24S12	24	12	167	20	110	78
HL02U24S15	24	15	133	20	110	78
HL02U05D05	5	$\pm 5$	$\pm 200$	40	540	74
HL02U05D12	5	$\pm 12$	$\pm 83$	40	490	82
HL02U05D15	5	$\pm 15$	$\pm 67$	40	490	82
HL02U12D05	12	$\pm 5$	$\pm 200$	30	230	72
HL02U12D12	12	$\pm 12$	$\pm 83$	30	210	79
HL02U12D15	12	$\pm 15$	$\pm 67$	30	210	79
HL02U15D05	15	$\pm 5$	$\pm 200$	30	190	70
HL02U15D12	15	$\pm 12$	$\pm 83$	30	170	78
HL02U15D15	15	$\pm 15$	$\pm 67$	30	170	78
HL02U24D05	24	$\pm 5$	$\pm 200$	20	120	72
HL02U24D12	24	$\pm 12$	$\pm 83$	20	110	78
HL02U24D15	24	$\pm 15$	$\pm 67$	20	110	78

# COMMON SPECIFICATIONS

Specifications typical at  $T_A = +25^\circ\text{C}$ , nominal input voltage, rated output current unless otherwise specified.

PARAMETER	CONDITIONS	MIN	TYP	MAX	UNITS
<b>INPUT</b>					
Voltage Range		4.75 11.4 14.25 22.8	5 12 15 24 30	5.25 12.6 15.75 26.2 100	VDC
Reflected Ripple Current					mAp-p
<b>ISOLATION</b>					
Rated Voltage		500			VDC
Test Voltage	60 Hz, 10 Seconds	500			Vpk
Resistance			1		G $\Omega$
Capacitance			25		pF
Leakage Current	$V_{iso} = 240\text{VAC}, 60\text{Hz}$		2		$\mu\text{Arms}$
<b>OUTPUT</b>					
Rated Power			2		W
Voltage Setpoint Accuracy			$\pm 3$	$\pm 5$	%
Temperature Coefficient			$\pm 0.02$		$\% / ^\circ\text{C}$
Ripple & Noise	BW = DC to 10MHz BW = 10Hz to 2MHz		50 10	100	mVp-p mVrms
Line Regulation	High Line to Low Line		$\pm 1$	$\pm 1.5$	$\% / \%$
Load Regulation	Rated Load to 1/4 Load		$\pm 3$	$\pm 15$	%
<b>GENERAL</b>					
Switching Frequency			110		kHz
Package Weight			12		g
MTTF per MIL-HDBK-217, Rev. F	Circuit Stress Method		200		kHr
Ground Benign	$T_A = +25^\circ\text{C}$ $T_A = +70^\circ\text{C}$		40		kHr
<b>TEMPERATURE</b>					
Specification		-25		+70	$^\circ\text{C}$
Operation		-40		+85	$^\circ\text{C}$
Storage		-40		+110	$^\circ\text{C}$

# MECHANICAL Package/Pinout "Y" and "Z"

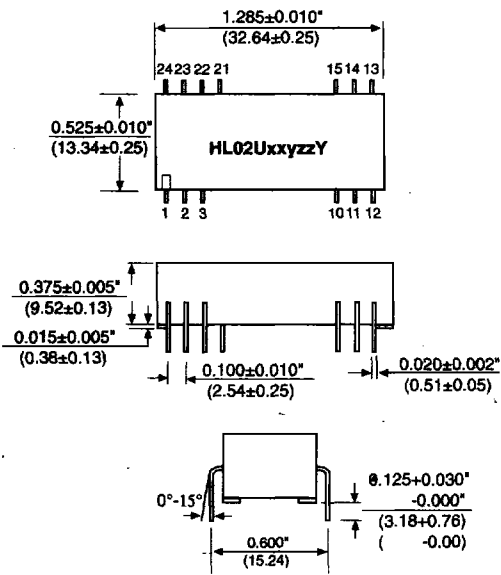

**DIP PACKAGE**

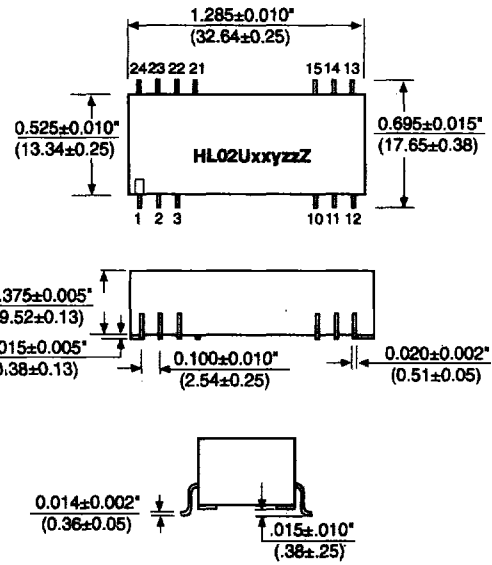

**SMD PACKAGE**

NU = Do Not Use.

NC = No Internal Connection.

Duplicate pin functions are internally connected.

All dimensions are in inches (millimeters).

GRID: 0.100 inches (2.54 millimeters)

Typically Marked with: specific model ordered, date code, job code and Logo.

**MATERIAL:** Units are encapsulated with a low thermal resistance molding compound which has excellent chemical resistance, wide operating temperature range, and good electrical properties even in high humidity environments. The encapsulant and outer shell of the unit have UL94V-0 ratings. Lead material is phosphor bronze with a solder plated surface to allow ease of solderability.

PIN CONNECTIONS		
PIN#	SINGLES	DUALS
1	+VIN	+VIN
2	NU	-VOUT
3	NU	Common
10	-VOUT	Common
11	+VOUT	+VOUT
12	-VIN	-VIN
13	-VIN	-VIN
14	+VOUT	+VOUT
15	-VOUT	Common
21	NC	NC
22	NU	Common
23	NU	-VOUT
24	+VIN	+VIN

## RECOMMENDED LAND PATTERN

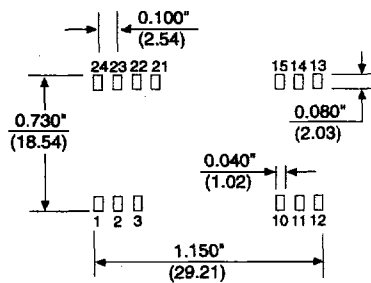

## RECOMMENDED REFLOW PROFILE

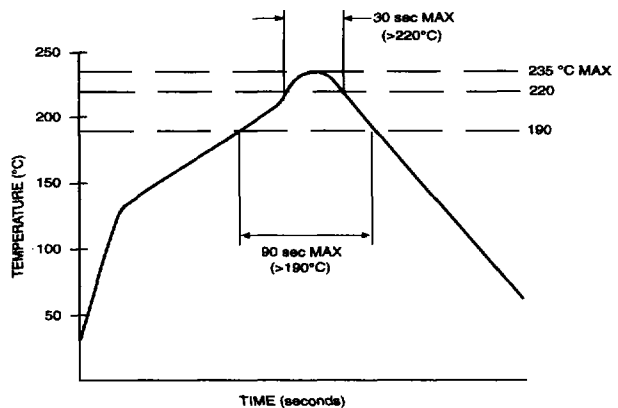

# TYPICAL PERFORMANCE CURVES

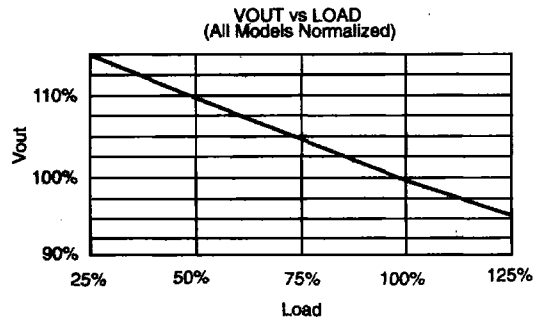
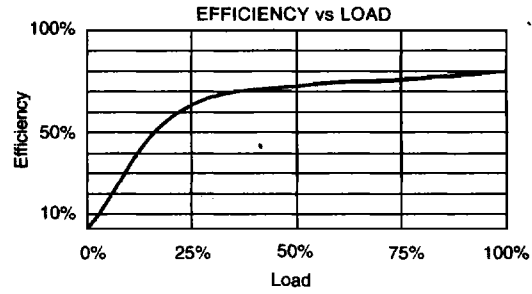
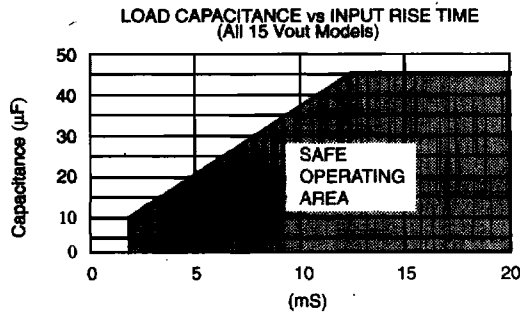
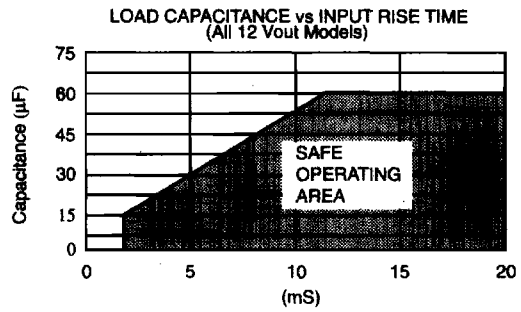
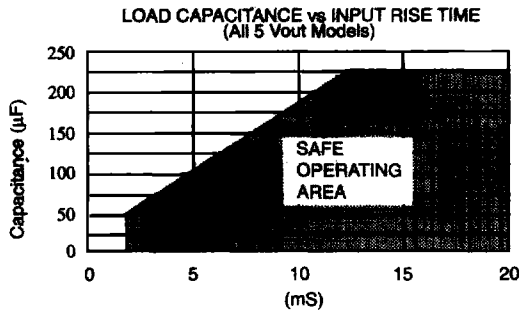

## NOTES:

- 1.) When operated within the SAFE OPERATING AREA as defined by the above curves, the output voltage of HL02U devices is guaranteed to be within 95% of its steady-state value within 100 milliseconds after the input voltage has reached 95% of its steady-state value.
- 2.) For dual output models, total load capacitance is the sum of the capacitances on the plus and minus outputs.