

Dear customer

LAPIS Semiconductor Co., Ltd. ("LAPIS Semiconductor"), on the 1st day of October, 2020, implemented the incorporation-type company split (shinsetsu-bunkatsu) in which LAPIS established a new company, LAPIS Technology Co., Ltd. ("LAPIS Technology") and LAPIS Technology succeeded LAPIS Semiconductor's LSI business.

Therefore, all references to "LAPIS Semiconductor Co., Ltd.", "LAPIS Semiconductor" and/or "LAPIS" in this document shall be replaced with "LAPIS Technology Co., Ltd."

Furthermore, there are no changes to the documents relating to our products other than the company name, the company trademark, logo, etc.

Thank you for your understanding.

LAPIS Technology Co., Ltd.
October 1, 2020

ML9478C

Static, 1/2 Duty, 1/3 Duty, 1/4 Duty 80 Outputs LCD Driver

GENERAL DESCRIPTION

The ML9478C is an LCD driver LSI, consists of a 80-bit shift register, a 320-bit data latch, 80 sets of LCD drivers, and a common signal generation circuit.

It can directly drive an LCD up to 80 segments for static display, 160 segments for 1/2-duty display, 240 segments for 1/3-duty display, and 320 segments for 1/4-duty display.

The three-wire serial interface and I²C interface are selectable.

FEATURES

- Logic power supply voltage : 2.7 to 5.5 V
- LCD drive power supply voltage : 4.5 to 5.5 V
- Maximum number of segments
 - Static display : 80 segments
 - 1/2-duty display : 160 segments
 - 1/3-duty display : 240 segments
 - 1/4-duty display : 320 segments
- Interface with microcomputer :
 - Serial interface : DATA, CLOCK, LOAD
 - CLOCK transfer speed up to 1 MHz
 - I²C interface : SDA, SCL, SDAACK
 - SCL transfer speed up to 400 kHz
- Built-in CR oscillator circuit using the internal resistor or External resistor
- Cascade connectable (up to sixteen chips)
- Built-in common signal generation circuit
- Built-in common output intermediate-value voltage generation circuit
- Built-in POC (Power On Clear) circuit
- Gold bump chip (ML9478CDVWA)

BLOCK DIAGRAM

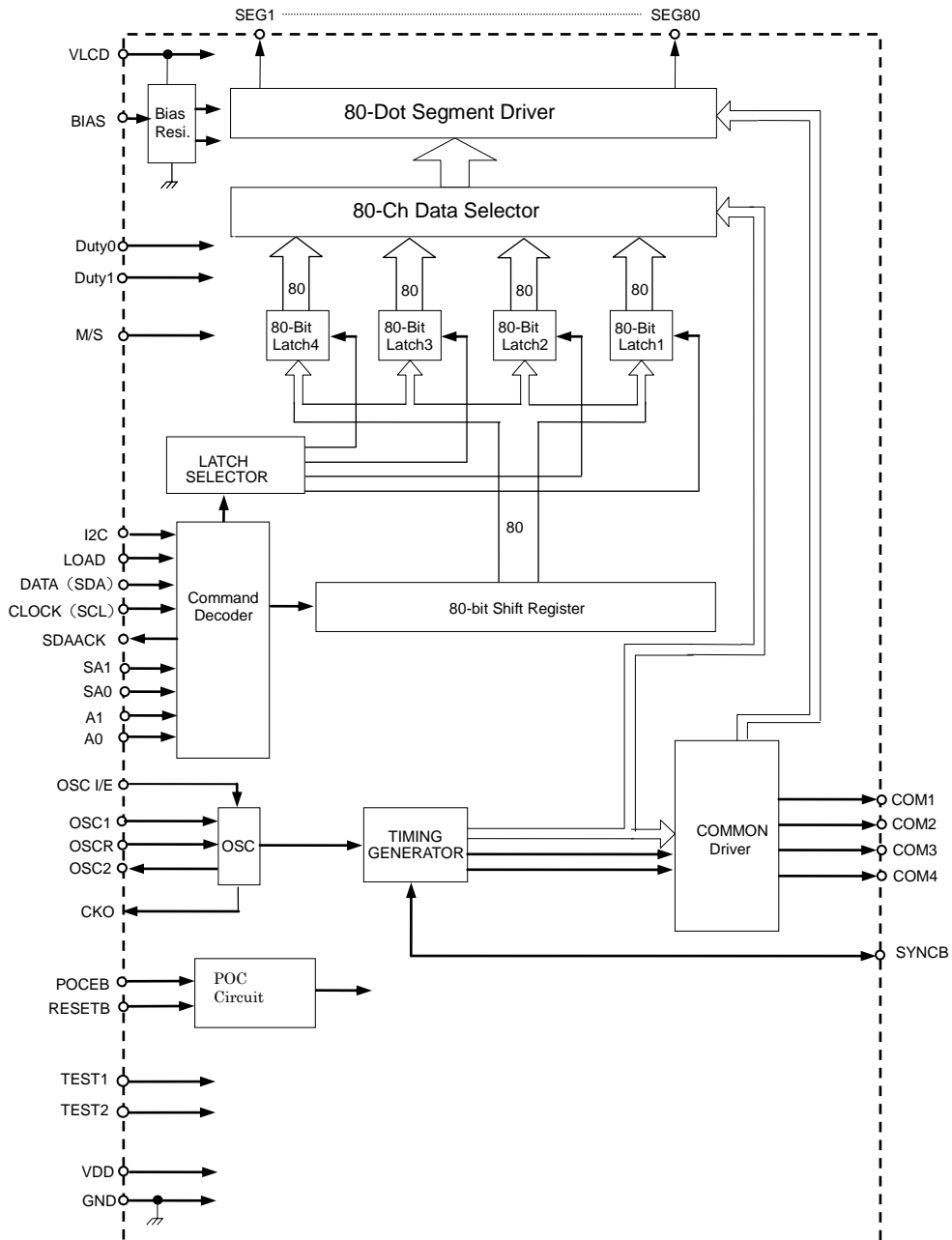

ABSOLUTE MAXIMUM RATINGS

Item	Symbol	Condition	Rating	Unit
Logic power supply voltage	V _{DD}	T _a = 25°C	-0.3 to 6.0	V
LCD drive power supply voltage	V _{LCD}	T _a = 25°C	-0.3 to 6.0	V
Input voltage	V _I	T _a = 25°C	- 0.3 to V _{DD} + 0.3	V
Output short-circuit current	I _S	T _a = 25°C	-2.0 to +2.0	mA
Chip temperature	T _C	—	125	°C
Storage temperature	T _{STG}	—	-55 to +150	°C

Note: Do not use the ML9478C by short-circuiting one output pin to another output pin as well as to other pin (input pin, input/output pin, or power supply pin).

RECOMMENDED OPERATION CONDITIONS

Item	Symbol	Condition	Range	Unit
Logic power supply voltage	V _{DD} *	—	2.7 to 5.5	V
LCD drive power supply voltage	V _{LCD} *	—	4.5 to 5.5	V
OSC IN clock frequency	f _{CP1}	—	up to 10	kHz
Data clock frequency	f _{CP2}	—	up to 1.0	MHz
SCL clock frequency	f _{SCL}	—	up to 400	kHz
Operating temperature	T _a	—	-40 to +105	°C

Note(*): Use at V_{DD} ≤ V_{LCD}.

The relation between OSC IN clock frequency and frame frequency is as the equation below.

$$f_{\text{FRM}} = f_{\text{OSC}} / 24$$

Recommended setting range for external component (oscillator circuit)

(V_{DD} = 2.7 to 5.5 V, V_{LCD} = 4.5 to 5.5 V, T_a = -40 to +105°C)

Item	Symbol	Condition	Min	TYP	Max	Unit
Oscillation resistor	R _f	—	423	470	517	kΩ
Frame frequency	f _{FRM}	(F1,F0)=(0,1)	47	75	114	Hz

The relation between oscillation resistor and frame frequency is as the equation below.

$$f_{\text{FRM}} = f_{\text{OSC}} / (16 \times 24)$$

$$f_{\text{OSC}} = 1 / (\text{Device coefficient} \times \text{External resistor } R_f)$$

$$\text{Device coefficient} = 73.8 \times 10^{-12} \pm 25\%$$

ELECTRICAL CHARACTERISTICS

DC Characteristics

($V_{DD} = 2.7$ to 5.5 V, $V_{LCD} = 4.5$ to 5.5 V, $T_a = -40$ to $+105^\circ\text{C}$)

Item	Symbol	Condition	Min.	Typ.	Max.	Unit	Applicable pin	
"H" input voltage	V_{IH}	—	$0.8V_{DD}$	—	V_{DD}	V	(*1)	
"L" input voltage	V_{IL}	—	GND	—	$0.2V_{DD}$	V	(*1)	
Input leakage current 1	I_{L1}	$V_I = V_{DD}$ or 0 V	-1.0	—	1.0	μA	(*8)	
Input leakage current 2	I_{L2}	$V_I = V_{DD}$ or 0V POCEB="H"	-1.0	—	1.0	μA	RESETB	
Pull-up current	I_{pu}	$V_{DD} = 5.0\text{V}$, $V_I = 0$ V POCEB = "L"	30	—	140	μA	RESETB	
"H" output voltage	V_{OH}	$I_O = -600\mu\text{A}$	$0.9V_{DD}$	—	—	V	CKO, SYNCB	
"L" output voltage 1	V_{OL1}	$I_O = 600\mu\text{A}$	—	—	$0.1V_{DD}$	V	CKO, SYNCB	
"L" output voltage 2	V_{OL2}	$I_O = 600\mu\text{A}$	—	—	$0.1V_{DD}$	V	SDAACK	
Driver ON resistor	Segment	V_{OHS}	$V_{LCD} = 5\text{V}$	—	5	15	$\text{k}\Omega$	SEG1 to SEG80
	Common	V_{OHC}	$V_{LCD} = 5\text{V}$	—	5	12	$\text{k}\Omega$	COM 1 to COM4

(*1): DATA(SDA), CLOCK(SCL), LOAD, M/S, SYNCB, Duty1, Duty0, BIAS, SA1,SA0, A1, A0, OSC1, OSC I/E, I2C, POCEB, **RESETB**

(*8): DATA(SDA), CLOCK(SCL), LOAD, M/S, SYNCB, Duty1, Duty0, BIAS, SA1, SA0, A1, A0, OSC1, OSC I/E, I2C, POCEB

($V_{DD} = 2.7$ to 5.5 V, $V_{LCD} = 4.5$ to 5.5 V, $T_a = -40$ to $+105^\circ\text{C}$)

Item	Symbol	Condition	Min.	Typ.	Max.	Unit	Applicable pin	
Static supply current	I_{DD5}	$V_{DD}=V_{LCD}=5.5$ V Input pin fixed to "H" or "L"	—	8	15	μA	VDD	
	I_{LCD5}	Oscillation stopped, output no-load POCEB="L"	—	9	15	μA	VLCD	
Dynamic supply current 1	I_{DD1}	$V_{DD}=V_{LCD}= 5.5$ V (*2)(*3) Clock OSC1 external input	(*6)	—	10	18	μA	VDD
	I_{LCD1}	$f_{CP1}=1.8\text{kHz}$	(*7)	—	9	15	μA	VLCD
Dynamic supply current 2	I_{DD2}	$V_{DD}=V_{LCD}= 5.5$ V (*2)(*3) Internal oscillation	(*6)	—	61	90	μA	VDD
	I_{LCD2}		(*7)	—	9	15	μA	VLCD
Dynamic supply current 3	I_{DD3}	$V_{DD}=V_{LCD}= 5.5$ V (*2)(*4)(*6) Internal oscillation	—	130	250	μA	VDD	
	I_{LCD3}	At three-wire serial IF data input	—	9	15	μA	VLCD	
Dynamic supply current 4	I_{DD4}	$V_{DD}=V_{LCD}= 5.5$ V (*2)(*5)(*6) Internal oscillation	—	202	330	μA	VDD	
	I_{LCD4}	At I ² C IF data input	—	9	15	μA	VLCD	

(*2): M/S = "H", 1/4-duty, 1/3-bias, (F1,F0) = (1,1) 95 Hz, POCEB = "L", output pin no-load.

(*3): Three-wire serial or I²C interface. Input pin fixed to "H" or "L".

(*4): Serial interface, data input frequency = 1 MHz.

(*5): I²C interface, data input frequency = 400 kHz.

(*6): Alternately inputs "0" and "1" for LCD display data (checkered display).

(*7): Inputs all "1s" for LCD display data (all illuminated).

Switching Characteristics

- OSC timing

($V_{DD} = 2.7$ to 5.5 V, $V_{LCD} = 4.5$ to 5.5 V, $T_a = -40$ to $+105^\circ\text{C}$)

Item	Symbol	Condition	Min.	Typ.	Max.	Unit	Applicable pin
OSC IN clock frequency (external input)	f_{CP1}	Clock input from OSC1. OSC2 and OSCR open. OSC I/E = "L"	—	1.8	10	kHz	OSC1
Clock pulse width (External input)	t_{WCP1}		40	—	—	μs	OSC1
Clock rise and fall time (external input)	t_{OSC}		—	—	(*1)	μs	OSC1
External Rf clock frequency (Internal oscillation)	f_{OSC1}	Between OSC1 and OSC2 $R_f = 470\text{k}\Omega$ (F1,F0)=(0,1) OSCR open. OSC I/E = "H"	18	28.8	44	kHz	OSC1, OSC2
Internal clock frequency (Internal oscillation)	f_{OSC2}	OSC1 open. (F1,F0)=(0,1) OSC2 and OSCR short-circuited. OSC I/E = "H"	18	28.8	44	kHz	OSC1, OSCR, OSC2

The relation between OSC IN clock frequency and frame frequency is as the equation below.

$$f_{FRM} = f_{OSC} / 24$$

(*1) t_{OSC} is a reference value.

The longer the clock rise and fall time, the more susceptible to extraneous noises around the threshold value.
Make the rise as steep as possible. Reference value: $\text{max}=2\mu\text{s}$.

- Serial interface timing

($V_{DD} = 2.7$ to 5.5 V, $V_{LCD} = 4.5$ to 5.5 V, $T_a = -40$ to $+105^\circ\text{C}$)

Item	Symbol	Condition	Min.	Typ.	Max.	Unit	Applicable pin
Data clock frequency	f_{CP2}		—	—	1	MHz	CLOCK
Data clock pulse width	t_{WCP2}		100	—	—	ns	CLOCK
Data setup time	t_{SU}		50	—	—	ns	DATA
Data hold time	t_{HD}		50	—	—	ns	CLOCK
CLOCK-LOAD timing	t_{CL}		100	—	—	ns	CLOCK
LOAD-CLOCK timing	t_{LC}		100	—	—	ns	LOAD
LOAD pulse width	t_{WLD}		100	—	—	ns	LOAD
Signal rise and fall time	t_{sr}, t_{sf}		—	—	(*2)	ns	CLOCK, DATA, LOAD

(*2) t_{sr} and t_{sf} shall be reference values.

The longer the clock rise and fall time, the more susceptible to extraneous noises around the threshold value.
Make the rise as steep as possible. Reference value: $\text{max}=10\text{ns}$.

- I²C interface timing

(V_{DD} = 2.7 to 5.5 V, V_{LCD} = 4.5 to 5.5 V, Ta = -40 to +105°C)

Item	Symbol	Condition	Min.	Typ.	Max.	Unit	Applicable pin
SCL clock frequency	f _{SCL}		—	—	400	kHz	SCL
Hold time (repeat) "STATRT" condition	t _{HD,STA}		0.6	—	—	μs	SCL,SDA
SCL "L" pulse width	t _{LOW}		1.3	—	—	μs	SCL
SCL "H" pulse width	t _{HIGH}		0.6	—	—	μs	SCL
Setup time for repeat "START" condition	t _{SU,STA}		0.6	—	—	μs	SCL,SDA
Data hold time	t _{HD,DAT}		0	—	—	ns	SCL,SDA
Data setup time	t _{SU,DAT}		200	—	—	ns	SCL,SDA
Setup time for "STOP" condition	t _{SU,STO}		0.6	—	—	μs	SCL,SDA
Bus free time between "STOP" condition and "START" condition	t _{BUF}		1.3	—	—	μs	SCL
Data valid acknowledge time	t _{VD,ACK}		—	—	1.2	μs	SCL,SDAAACK
Signal rise and fall time	t _{ir,tif}		—	—	(*3)	μs	SCL,SDA
Data bus load capacitance	C _b		—	—	400	pF	SDA,SDAAACK
Noise pulse width tolerance	t _{wf}		—	—	50	ns	SCL,SDA

(*3) t_{ir} and t_{tif} shall be reference values.

The longer the clock rise and fall time, the more susceptible to extraneous noises around the threshold value.
Make the rise as steep as possible. Reference value: max=0.1μs.

REFERENCE DATA

Frame frequency Characteristics

VDD=5.5V/2.7V Rf=470Ω

Frame frequency $f_{FRM} = f_{OSC} / (16 \times 24)$

$f_{OSC} = 1 / (\text{Device coefficient} \times \text{External resistor } R_f)$

Device coefficient = $73.8 \times 10^{-12} \pm 25\%$

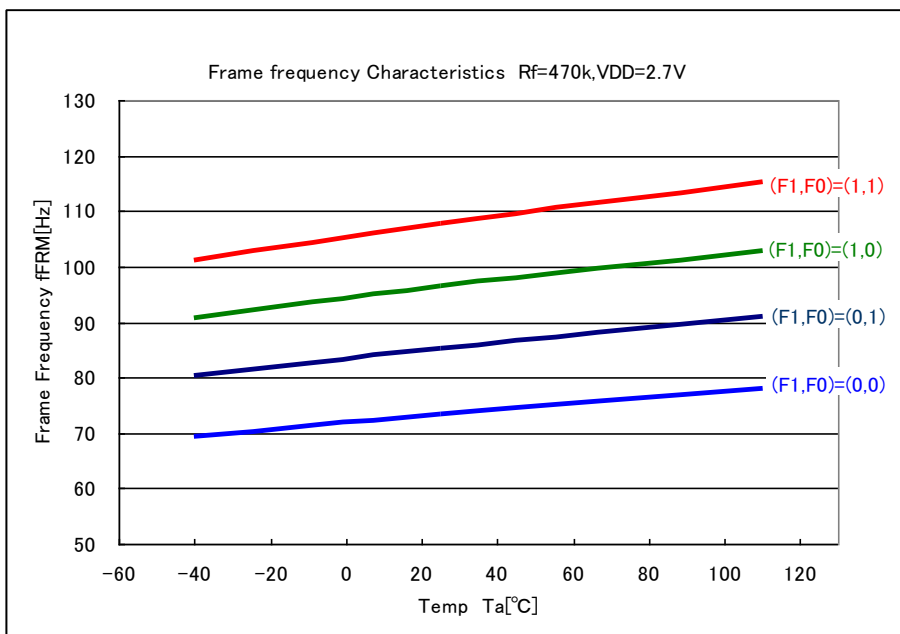
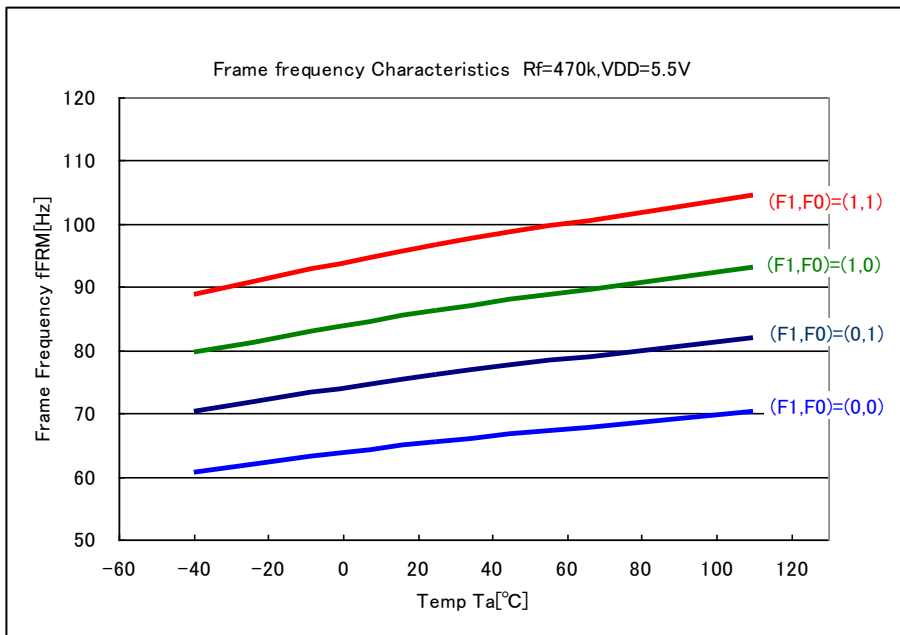

POWER ON/OFF TIMING

To turn on the power supply, raise the logic power supply first, then LCD drive power supply in order to prevent the IC from malfunctioning.

To fall the power supply, fall the LCD drive power supply first, then the logic power supply.

For a VDD pin ranging from 0 V to VDDmin, set $V_{DD} \geq V_{LCD}$ and $t_1 \geq 0$ [ns].

To enable the Internal POC circuit, the VDD power supply rise time t_2 range needs to be $100 [\mu s] \leq t_2 \leq 500$ [ms].

For the VDD power supply to turn OFF then turn ON again, it is necessary to secure the POC discharge time $t_3 \geq 100$ [ms].

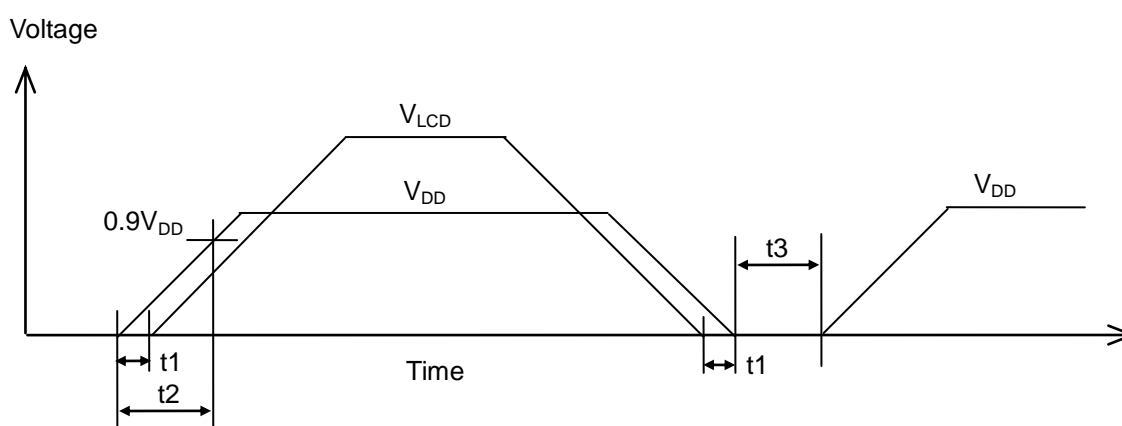

INITIALIZATION SIGNAL TIMING

When RESETB signal is externally input

The RESETB pin input is valid both for POCEB = "L" and "H". Usable in combination with the POC.

Keep the RESETB pin at "L" level until the VDD reaches VDDmin. ($t_4 \geq 200$ [ns])

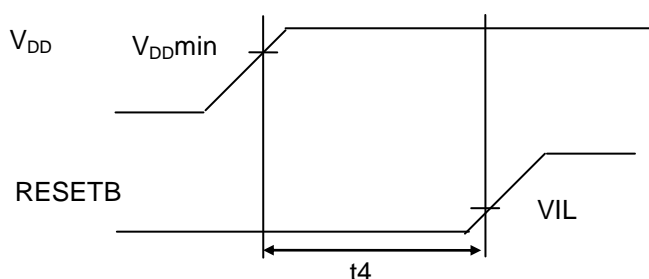

When Internal POC circuit is used

When using the Internal POC circuit in the initialization, set the POCEB pin to "L".

At this time, the power ON/OFF timing conditions are t₁ to t₃ above mentioned.

When RESETB pin POC circuit is used

If the power ON/OFF timing conditions t₁ to t₃ cannot be kept, the RESETB pin needs to have a capacitance to configure the POC circuit. For this case, connect a capacitance value according to the power supply rise time.

For the power supply rise time t₂ and external capacitance value, use the following formula as a guide:

$$C_{RST} [F] > t_2 [\text{sec}] / (30 \times 10^3)$$

PIN DESCRIPTIONS

Pad number	Symbol	I/O	Description
67-68	M/S	I	This is the input to switch between the master and slave modes. It has a schmitt circuit. When this pin is "H", the mode is master. When this pin is "L", the mode is slave.
6-7 4-5	Duty0 Duty1 *1	I	Display duty switch pins. These have schmitt circuits. Duty0="L", Duty1="L" : Static (COM1=COM2=COM3=COM4) Duty0="H", Duty1="L" : 1/2Duty (COM1=COM3, COM2=COM4) Duty0="L", Duty1="H" : 1/3Duty (COM2=COM4) Duty0="H", Duty1="H" : 1/4Duty
73-74	BIAS	I	This pin sets the LCD bias. It has a schmitt circuit. BIAS="L": 1/3bias BIAS="H": 1/2bias
14-15 12-13	SA1 SA0	I	Slave address input pins. These have schmitt circuits.
10-11 8-9	A1 A0	I	Sub address input pins. These have schmitt circuits.
71-72	OSC I/E	I	This input selects whether to use the external clock input mode or to use the Internal oscillation mode or external oscillation mode. It has a schmitt circuit. When this pin is "H", the mode is the Internal or external Rf oscillation mode. When this pin is "L", the mode is the external clock input mode. Use the slave chip as it is connected to GND.
46-48 53-55 49-52	OSC1, OSCR, OSC2 *2	I I O	These pins are for the oscillator circuit to generate common signals. The OSC1 and OSCR pins are input pins and have a schmitt circuit. OSC2 is an output pin. It becomes an output when the OSC I/E pin = "H" and a high impedance when the OSC I/E pin = "L". 【 In the master mode (M/S pin = "H") 】 Three types are selectable: Internal oscillation mode, external oscillation mode, and external clock input mode. •Internal oscillation mode: Set the OSC I/E pin to "H", short the OSCR and OSC2 pins, and open the OSC1 pin. •External Rf oscillation mode: Set the OSC I/E pin to "H", connect an oscillation resistor Rf between the OSC1 and OSC2 pins, and open the OSCR pin. •External clock input mode: Set the OSC I/E pin to "L", open the OSCR and OSC2 pins, and input the external clock to the OSC1 pin. 【 In the slave mode (M/S pin = "L") 】 Open the OSCR and OSC2 pins and connect the OSC1 pin to the ML9478C's CKO pin that has been set to the master mode.
56-56	CKO	O	Clock output pin. In the master mode (M/S pin = "H"), the 1/16 division signal of the oscillation frequency is output. In the slave mode (M/S pin = "L"), the output is fixed to "L". For a cascade connection, connect this pin to the OSC1 pin of the chip that has been set to the slave mode.

60-63	SYNCB	I/O	Input/output pin for common synchronization. It has a schmitt circuit. It becomes the synchronization signal output pin in the master mode (M/S pin = "H"). It becomes the synchronization signal input pin in the slave mode (M/S pin = "L"). For cascade connection, connect all of the involved ML9478Cs' SYNC pins by the common line.
65-66	I2C	I	Interface switching pin. It has a schmitt circuit. When this pin is "H", the interface is I ² C. When this pin is "L", the interface is three-wire serial.
20-21	DATA (SDA)	I	Display data input pin. It has a schmitt circuit. I2C="L": Serial interface; DATA Input the display data in the order of SEG80, SEG79, ... , SEG2, and SEG1. The display data turns on at "H" and turns off at "L". I2C="H": I ² C interface; SDA Input the display data in units of 8 bits. The display data turns on at "H" and turns off at "L". This pin has a built-in noise filter through which noises in widths up to 50 ns are removed. This noise filter is valid only when I2C = "H".
22-23	CLOCK (SCL)	I	Shift clock input pin for display data. It has a schmitt circuit. I2C="L": Serial interface; CLOCK The display data input to the DATA pin is serially input to the shift register at the CLOCK signal rise. I2C="H": I ² C interface; SCL The display data input to the SDA pin is serially input to the shift register at the SCL signal rise. This pin has a built-in noise filter through which noises in widths up to 50 ns are removed. This noise filter is valid only when I2C = "H".
24-25	LOAD	I	Input pin for the load signal of display data. It has a schmitt circuit. I2C="L": Serial interface; LOAD The display data in the shift register is transmitted as is to the segment driver for the "H" duration. When this pin is brought into "L", the shift register is disconnected from the segment driver. The display data in the shift register immediately before it become "L" is held in the data latch and transmitted to the segment driver. I2C="H": I ² C interface Use this pin as it is connected to GND.
17-19	SDAACK	O	I2C="L": Serial interface Use this pin as it is opened. I2C="H": I ² C interface The I ² C bus acknowledge output signal. Normally, use it as it is connected with the SDA pin. Connect an external pull-up resistor whenever necessary, as it is an open drain pin. The pull-up connection destination supply voltage shall be the V _{DD} supply voltage or less.
69-70	POCEB	I	Internal POC circuit enable pin. It has a schmitt circuit. When this pin is "H", the POC circuit becomes OFF and the constant current (8μA) is cut. The RESETB pin pull-up resistor is cut as well. When this pin is "L", the POC circuit becomes ON. The RESETB pin is connected to a pull-up resistor.
44-45	RESETB *3	I	Reset signal input pin for initializing inside the IC. It has a schmitt circuit. The "L" level enables the reset. This pin has an Internal pull-up resistor. Open when POCEB = "H". Pull-up when POCEB = "L". The power-on reset operation is available by connecting an external capacitor.

77-78 75-76	TEST1 TEST2	I	Pin for testing the IC. It has an Internal pull-down resistor. Use it as it is connected to GND.
95-134 139-178	SEG1 ~SEG80	O	Outputs for LCD display. Connected to the segment pins on the LCD panel. In the display off mode, all the outputs are fixed to GND.
85-88 135-138 183-186	COM1 ~COM4	O	Outputs for LCD display. Connected to the common pins on the LCD panel. The output pins are located at three positions: both ends of the chip and between SEG40 and SEG41. Each is connected inside the chip. Use the COM pins in accordance with the panel to be used. In the display off mode, all the outputs are fixed to GND. When the slave is set (M/S="L"), COM1 to COM4 outputs are GND level fixed.
32-37	VDD	-	Power supply pin for logic circuit.
38-43	VLCD	-	Power supply pin for LCD driver.
26-31	GND	-	Ground pin.
16 64	VDDO	-	VDD output pin. Use this pin when fixing the mode setting input pin to "H" on the COG.
3 79	GNDO	-	Ground output pin. Use this pin when fixing the mode setting input pin to "L" on the COG.
1-2 80-84 89-94 179-182 187-190	DUMMY	-	Floating pin. At this time, avoid this pin from shorting with pins other than DUMMY in the wiring on the COG.

*1: For details of the COM /SEG waveform when a duty is selected, refer to "Common waveform" on page 18 and "Common Segment waveform" on page 19 to 23.

*2: Oscillator circuit configuration

- When M/S = "H", OSC I/E = "H"

[Internal Rf oscillation mode]

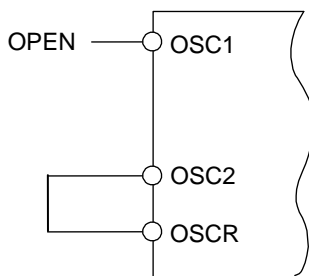

[External Rf oscillation mode]

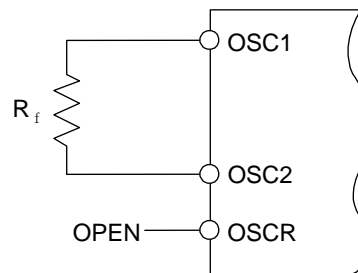

- External clock input mode when M/S = "H" and OSC I/E = "L"

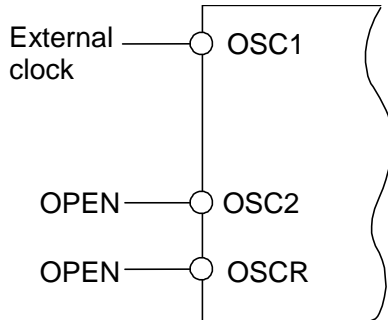

- M/S = "L", slave mode, external clock input mode

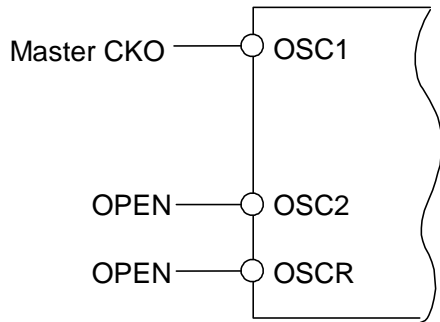

*3: Reset circuit configuration

- External input to RESETB when POCEB = "H"

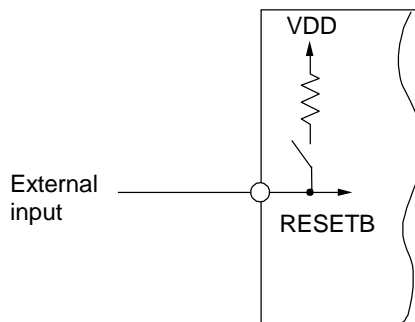

- POC circuit configuration when POCEB = "L"

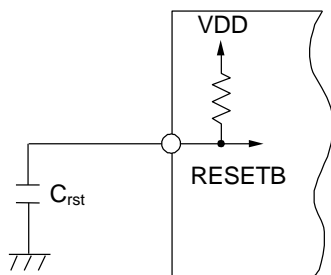

DESCRIPTION

Operation description (Serial interface)

• Display data input

As described in the Data configuration section, the display data consists of the data field that corresponds to each segment on/off and the command field that indicates the display data input. When inputting the display data, the "F3" command is set in the command field. When the "F1" or "F2" command is set in the command field, the display data in the data field becomes invalid. The data input to the DATA pin is loaded to the shift register at the CLOCK pulse rise, transferred to the display data latch during the LOAD pulse at the "H" level, then output via the segment driver.

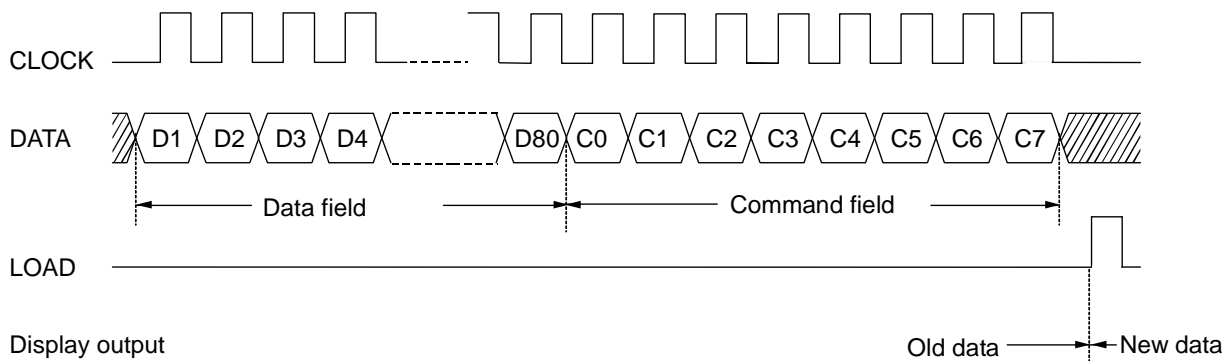

• Display on, Display off

The display becomes off at power-on reset. To display, write the display on command. The display off is the command that makes all segments off. Writing the display off command turns off the lights regardless of the display data. **The display off command is executed after 24 (maximum) OSC1 clocks are input.** The display on is the command to release the display off. Writing the display on command returns the display to the original state.

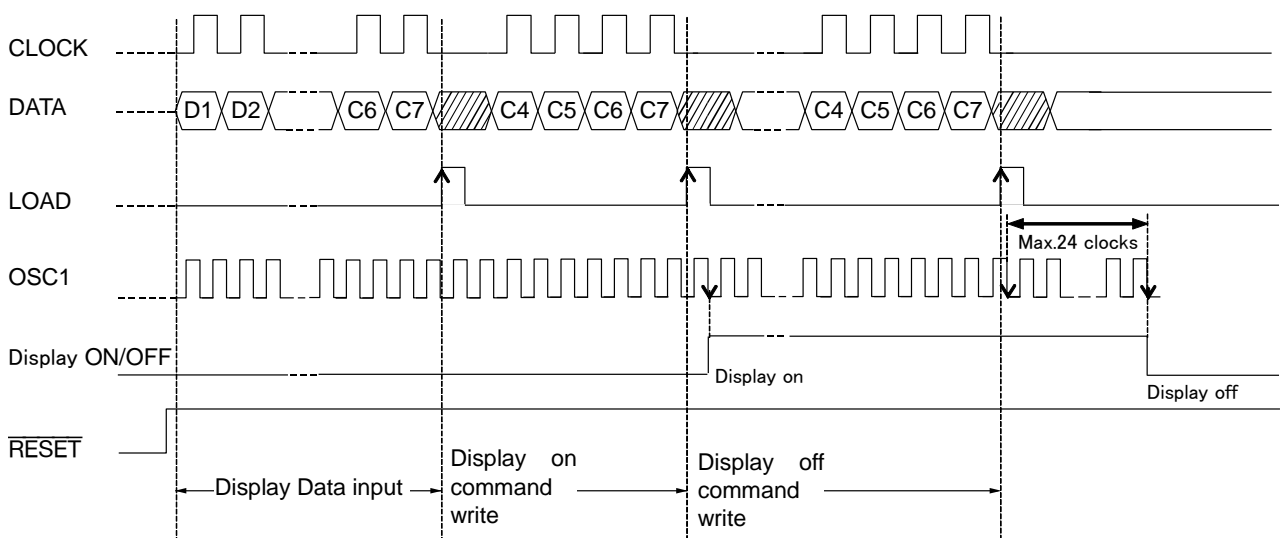

List of Commands

Command name	C7	C6	C5	C4	C3	C2	C1	C0	Operation
F0	0	0	0	0	x	x	x	x	Disabled
F1	0	1	F1 (*2)	F0 (*2)	x	x	x	x	Frame frequency setting (F1,F0)=(0, 0): 65Hz (F1,F0)=(0, 1): 75Hz (F1,F0)=(1, 0): 85Hz (F1,F0)=(1, 1): 95Hz (valid for Internal CR oscillation)
F2	1	0	1	D (*2)	x	x	x	x	Display on/off "0" : Off (COM=SEG=GND) "1" : On
F3(*1)	1	1	SA1	SA0	A1	A0	Co1	Co0	Data write address setting (Co1,Co0)=(0, 0): Corresponding to common 1 (Co1,Co0)=(0, 1): Corresponding to common 2 (Co1,Co0)=(1, 0): Corresponding to common 3 (Co1,Co0)=(1, 1): Corresponding to common 4 SA1, SA0, A1, A0: Chip address

x: Don't care

(*1): For the I²C interface, SA1 and SA0 are set at a slave address.
These bits become "Don't care".

(*2): The register is set to the following value by the RESETB = "L" input or by the power-on POC.
F1="0", F0="0", D="0"

Data configuration

- Data configuration (Serial interface)

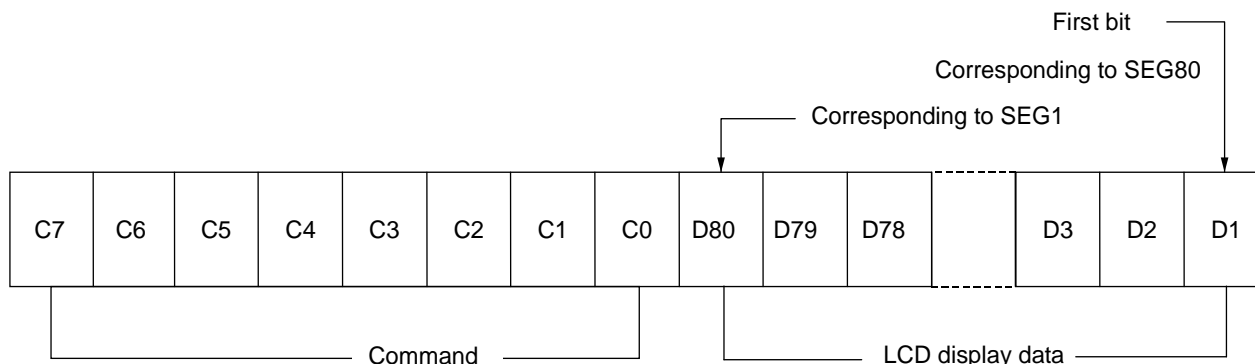

Note 1 : The commands F1 and F2 settings become valid when the least four bits of C4 to C7 are input.
(The bits from D1 to D80 and from C0 to C3 are not necessary.)

Note 2 : If the dummy bit is needed for the reason of number of transfer bits, put it on the first bit side.

Note 3 : The command execution follows the contents of the C7 to C0 registers immediately before the LOAD becomes "H".

• Data configuration (I²C interface)

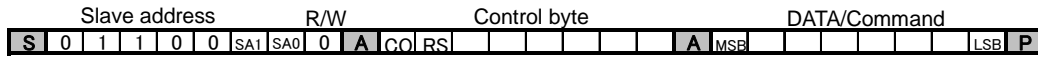

Slave address: 0 1 1 0 0 1

CO: Consecutive control byte setting bit
 0: Last control byte, 1: Consecutive control byte
 RS: Command/data setting bit
 0: Command data, 1: Display data

For the I²C interface, each IC is assigned with a 7-bit slave address. The first one byte in the transfer consists of this 7-bit slave address and the R/W bit that indicates the data transfer direction. Always input "0" to the eighth R/W bit because the ML9478C is a write-only LSI.

The eight bits next to the slave address is a control byte. The first one bit is CO: consecutive command setting bit and the next one bit is RS: command/data setting bit (the remaining six bits are the Don't care bits).

When CO = "0": Means the last control byte.

When CO = "1": Means the control bytes are successively input.

When RS = "0": Means the data to be input next is the command data.

When RS = "1": Means the data to be input next is the display data.

The display data can be successively input.

Example of Data Setting

- When inputting two commands

When inputting two commands

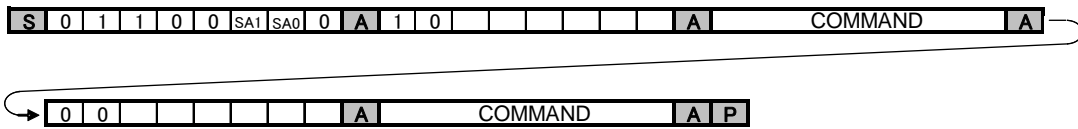

- When inputting the command and display data

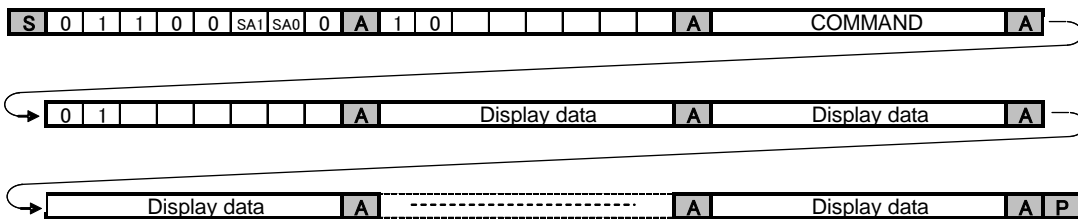

Data write method

• Serial interface

The data is written to the address set by the data write setting command (F3).

For the Serial interface, the data is written in units of 80 bits.

Written from D80 to SEG1, D79 to SEG2, ... , D2 to SEG79, and D1 to SEG80.

	MSB				Segment output								LSB			
	1	2	3	4	32	33	34	35	36	37	38	39	40			
COM1	D80	D79	D78	D77	D49	D48	D47	D46	D45	D44	D43	D42	D41			
COM2	D80	D79	D78	D77	D49	D48	D47	D46	D45	D44	D43	D42	D41			
COM3	D80	D79	D78	D77	D49	D48	D47	D46	D45	D44	D43	D42	D41			
COM4	D80	D79	D78	D77	D49	D48	D47	D46	D45	D44	D43	D42	D41			

	MSB				Segment output								LSB			
	41	42	43	44	72	73	74	75	76	77	78	79	80			
COM1	D40	D39	D38	D37	D9	D8	D7	D6	D5	D4	D3	D2	D1			
COM2	D40	D39	D38	D37	D9	D8	D7	D6	D5	D4	D3	D2	D1			
COM3	D40	D39	D38	D37	D9	D8	D7	D6	D5	D4	D3	D2	D1			
COM4	D40	D39	D38	D37	D9	D8	D7	D6	D5	D4	D3	D2	D1			

• I²C interface

The data is written to the address set by the slave address.

For the I²C interface, the data is written to the specified address starting with the LSB side in units of 8 bits.

(The data is written in the order from SEG73-80, SEG65-SEG72, ... , SEG9-16, and SEG1-SEG8.)

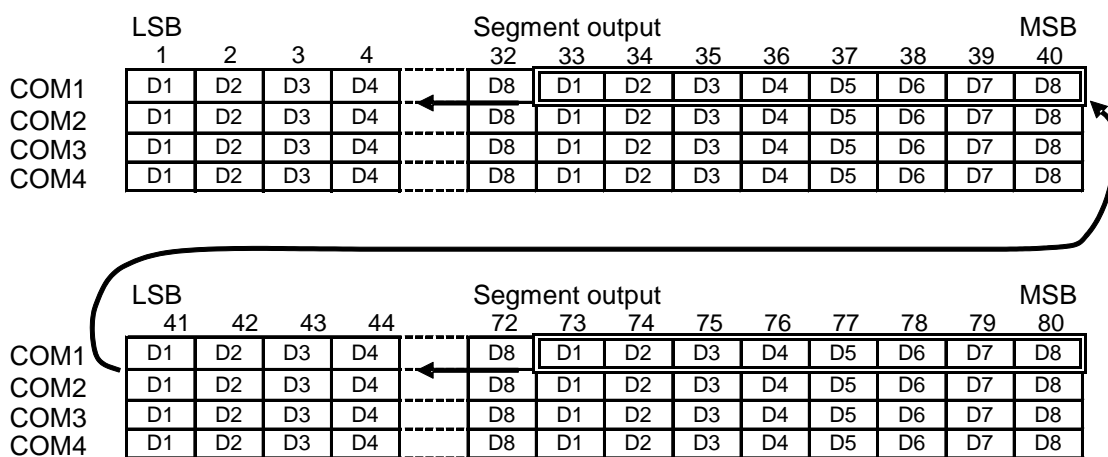

● Common waveforms

(1) At static

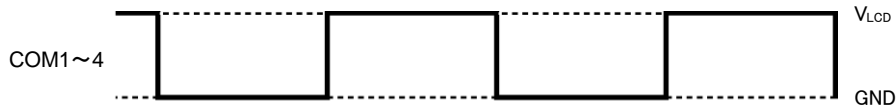

(2) At 1/2-duty

At 1/2-bias

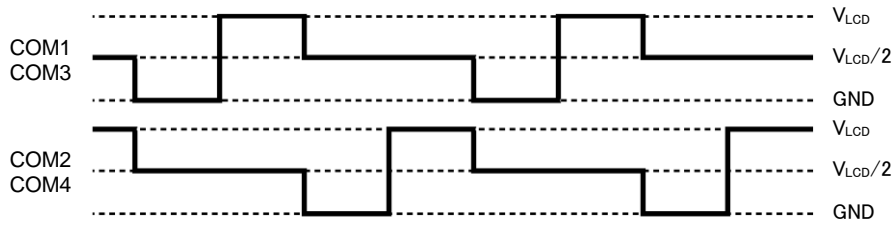

At 1/3-bias

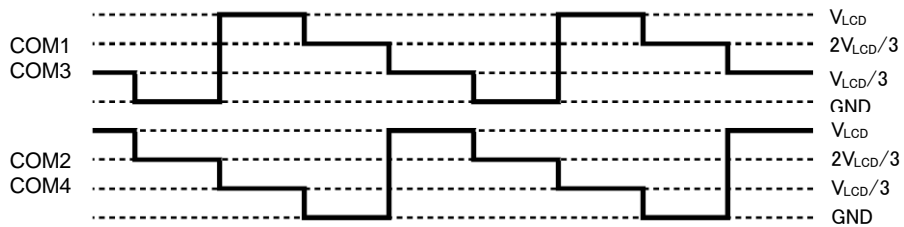

(3) At 1/3-duty

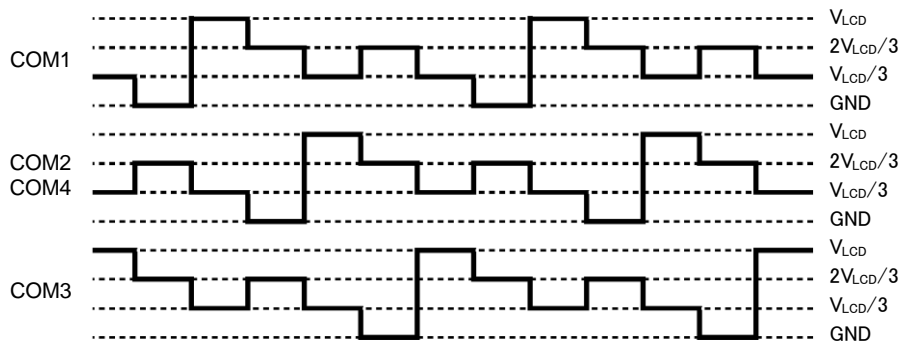

(4) At 1/4-duty

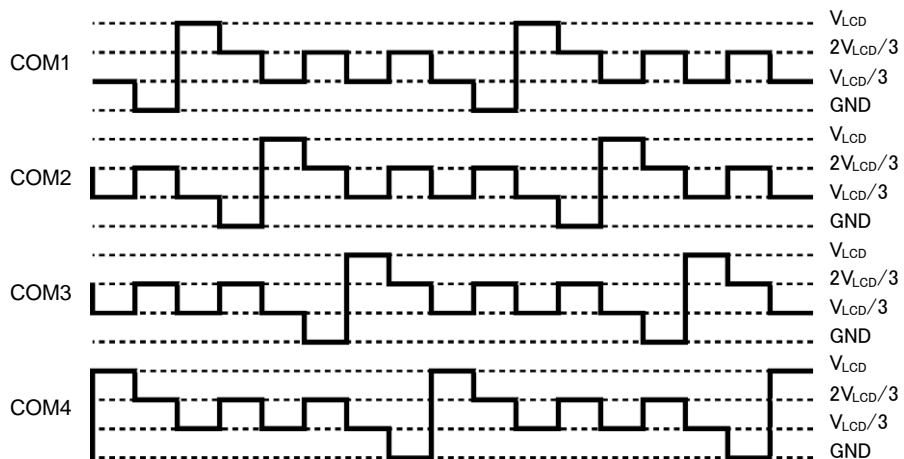

● Common segment output waveform
 •At Static

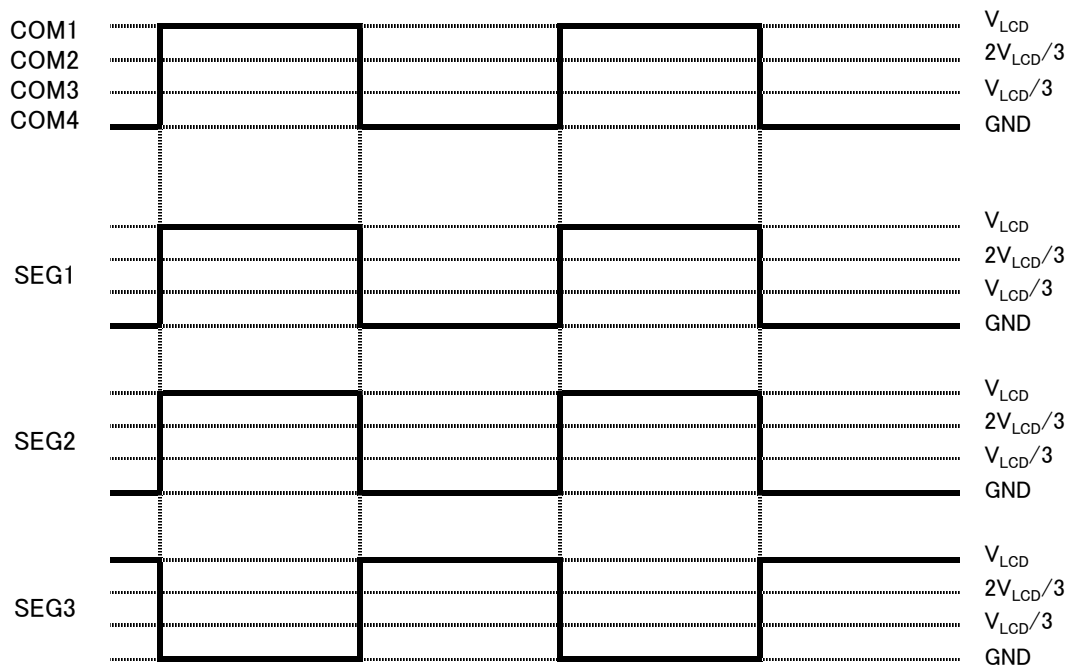
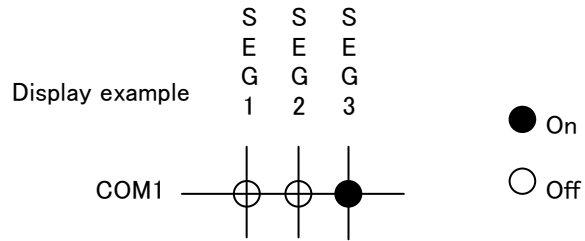

● Common and segment output waveforms

• At 1/2Duty, 1/2bias

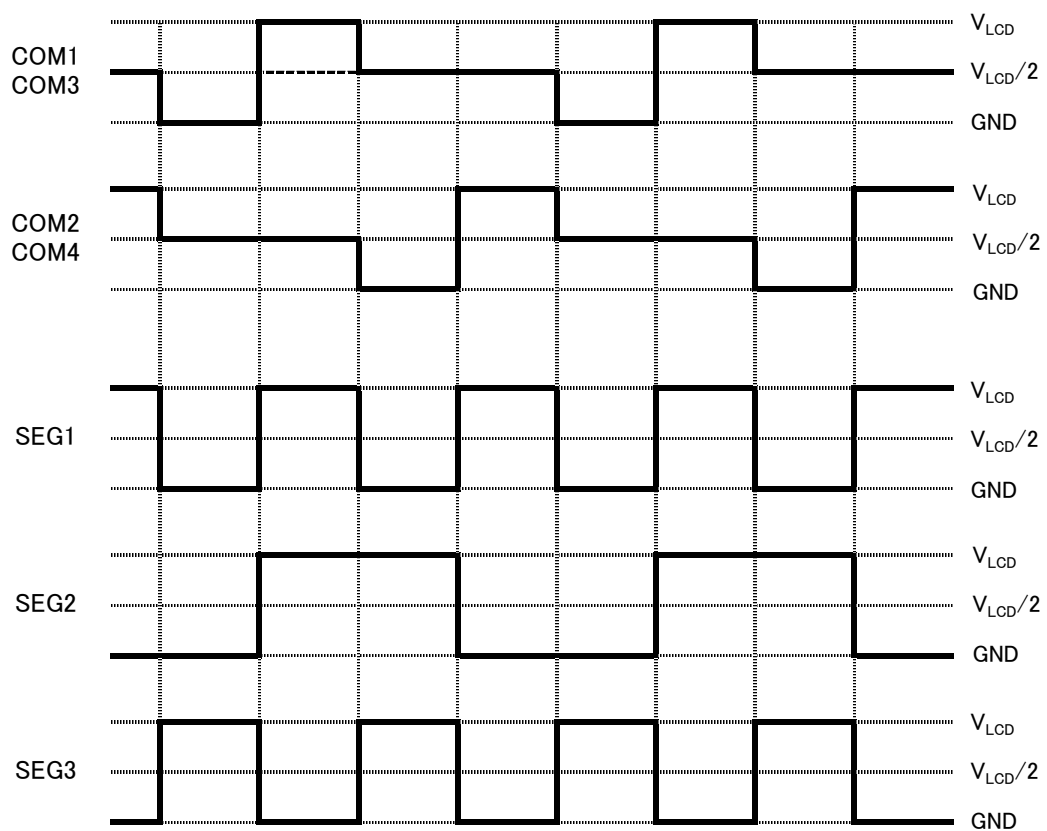
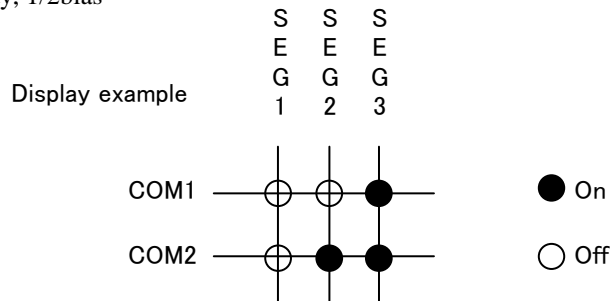

● Common and segment output waveforms

• At 1/2Duty, 1/3bias

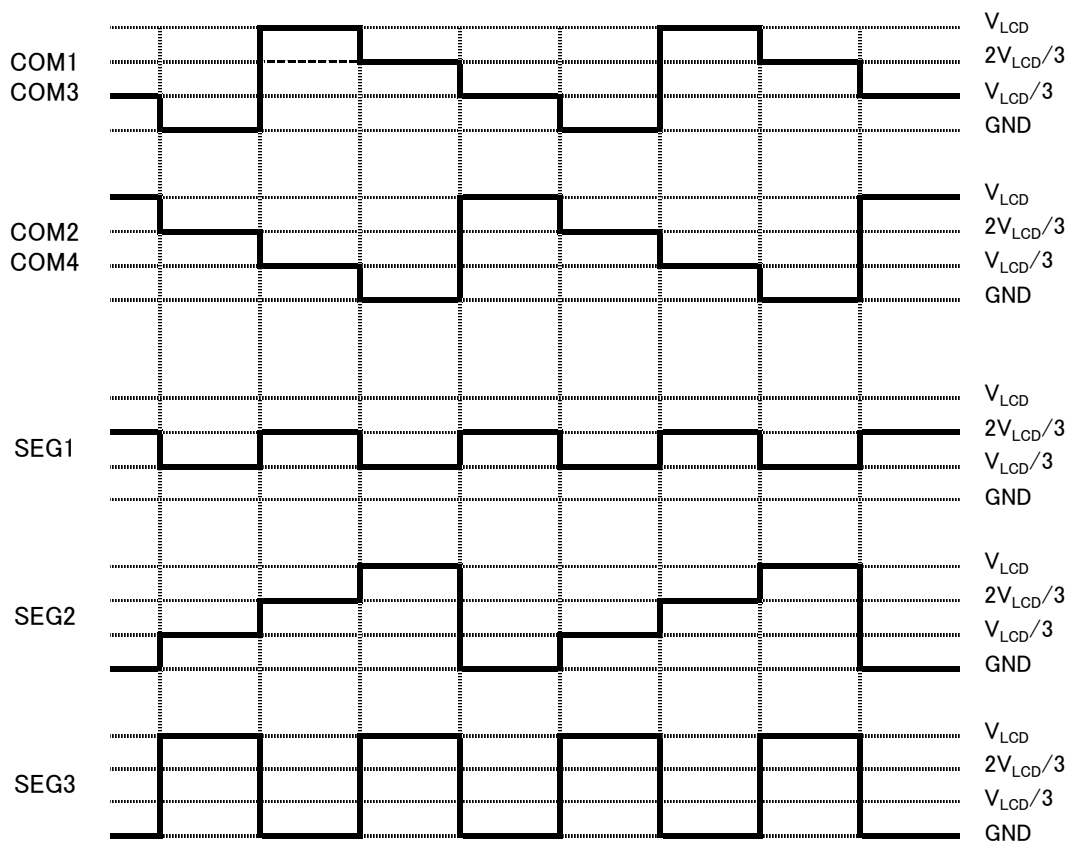
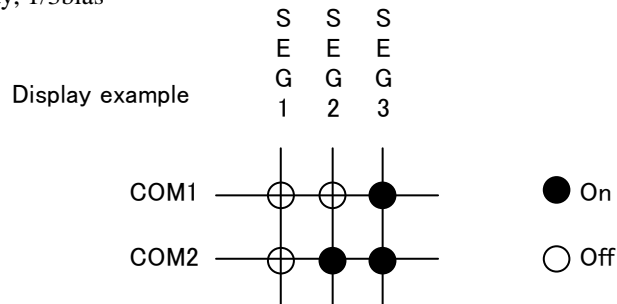

● Common and segment output waveforms

• At 1/3Duty, 1/3bias

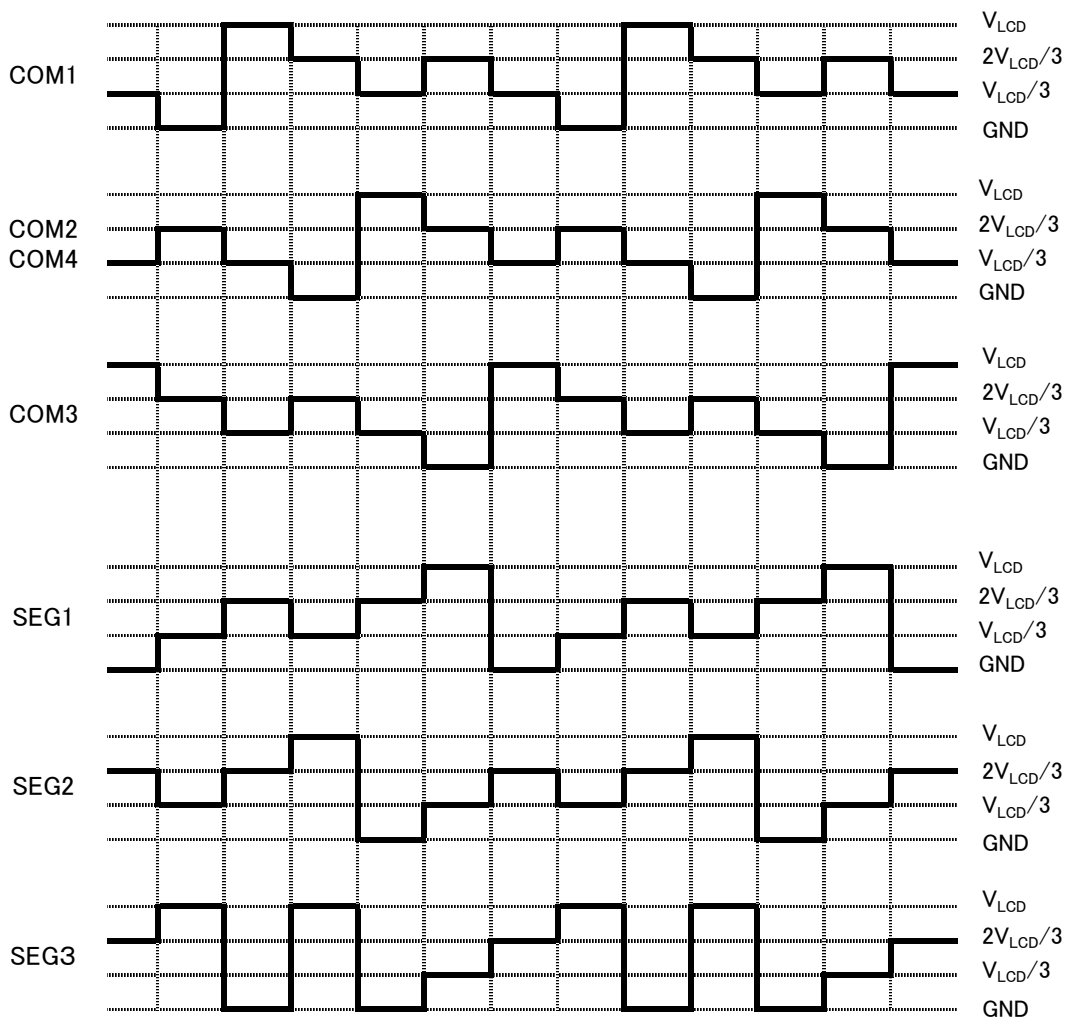
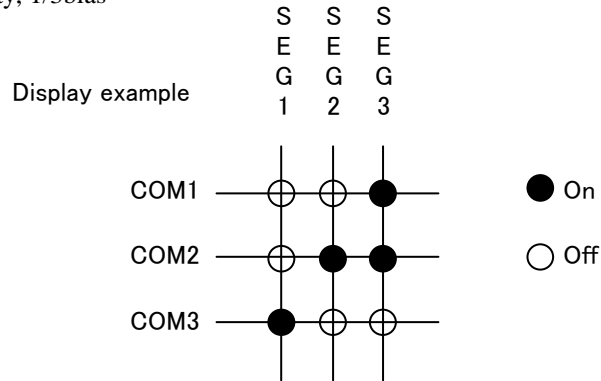

● Common and segment output waveforms
 • At 1/4Duty, 1/3bias

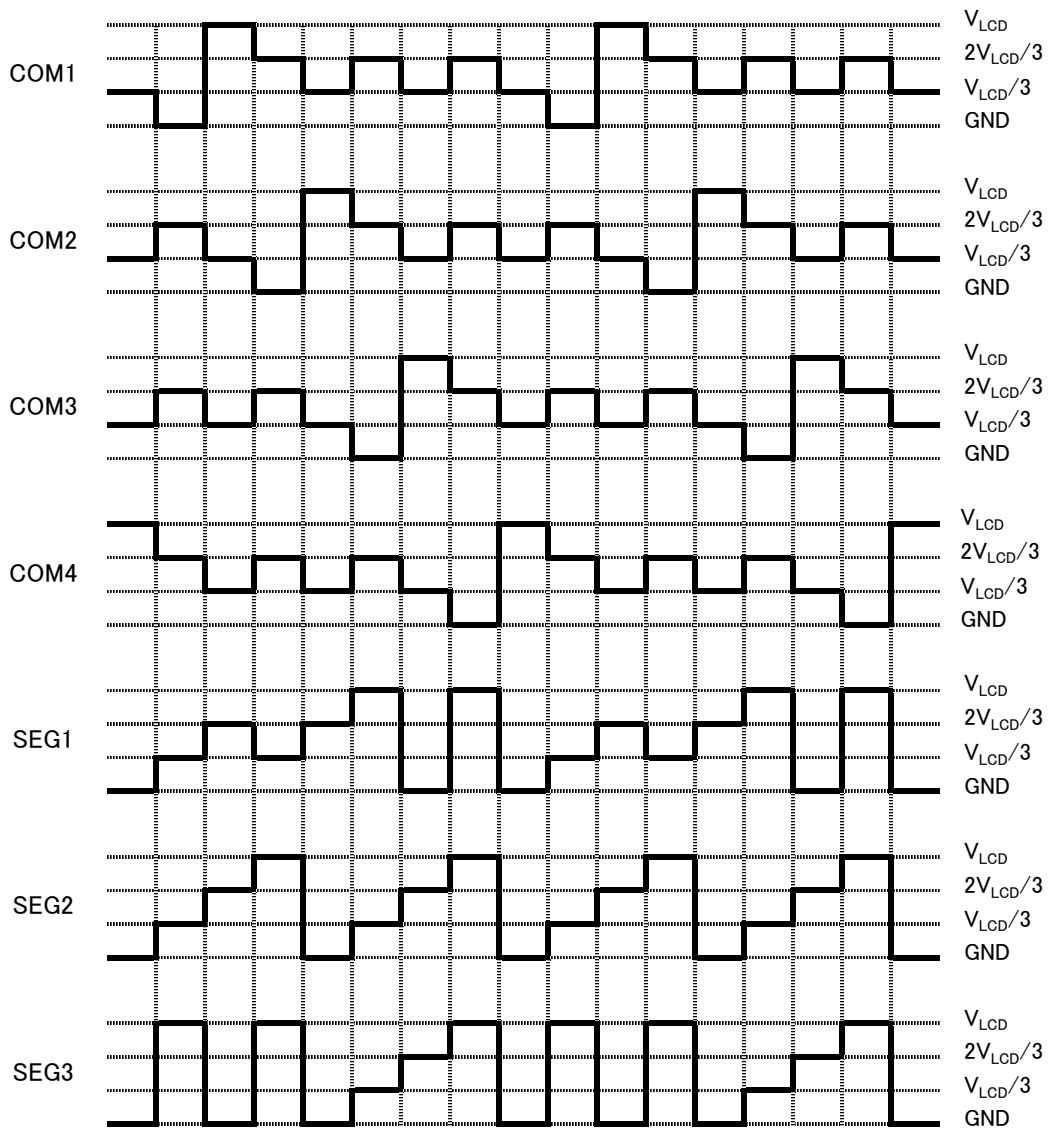
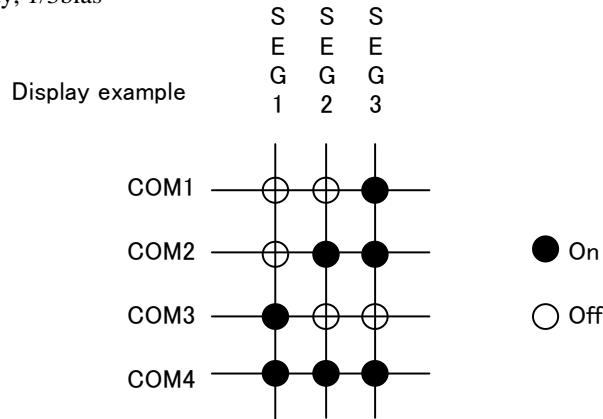

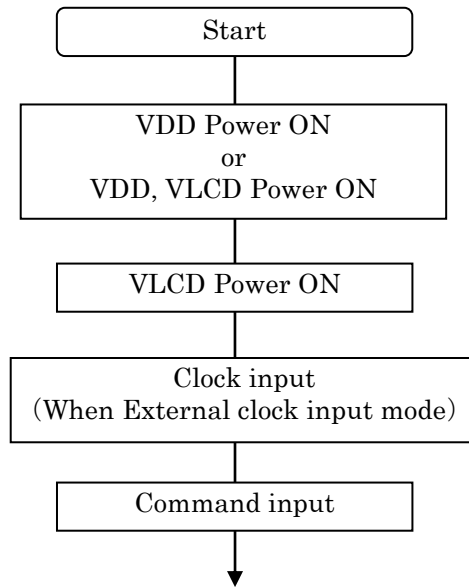
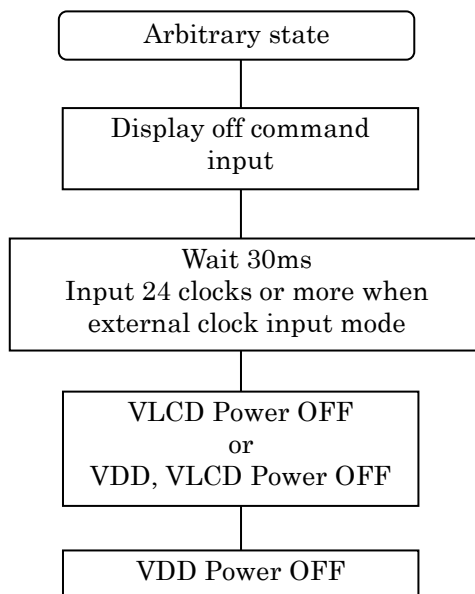
Power on Sequence**Power off Sequence**

EXAMPLE OF APPLICATION CIRCUIT

Cascade configuration 1

Serial interface

Internal CR oscillator circuit used

1/4Duty

RESETB pin + external capacitance connection to configure POC circuit

The common outputs of the slave chip output GND-level. So Com1 to Com4 set to open.

[External component]

$C_p = 0.1 \text{ } [\mu\text{F}]$ (bypass capacitor between power supplies)

$C_{rst} = 4.7 \text{ } [\mu\text{F}]$ (capacitance for external POC circuit)

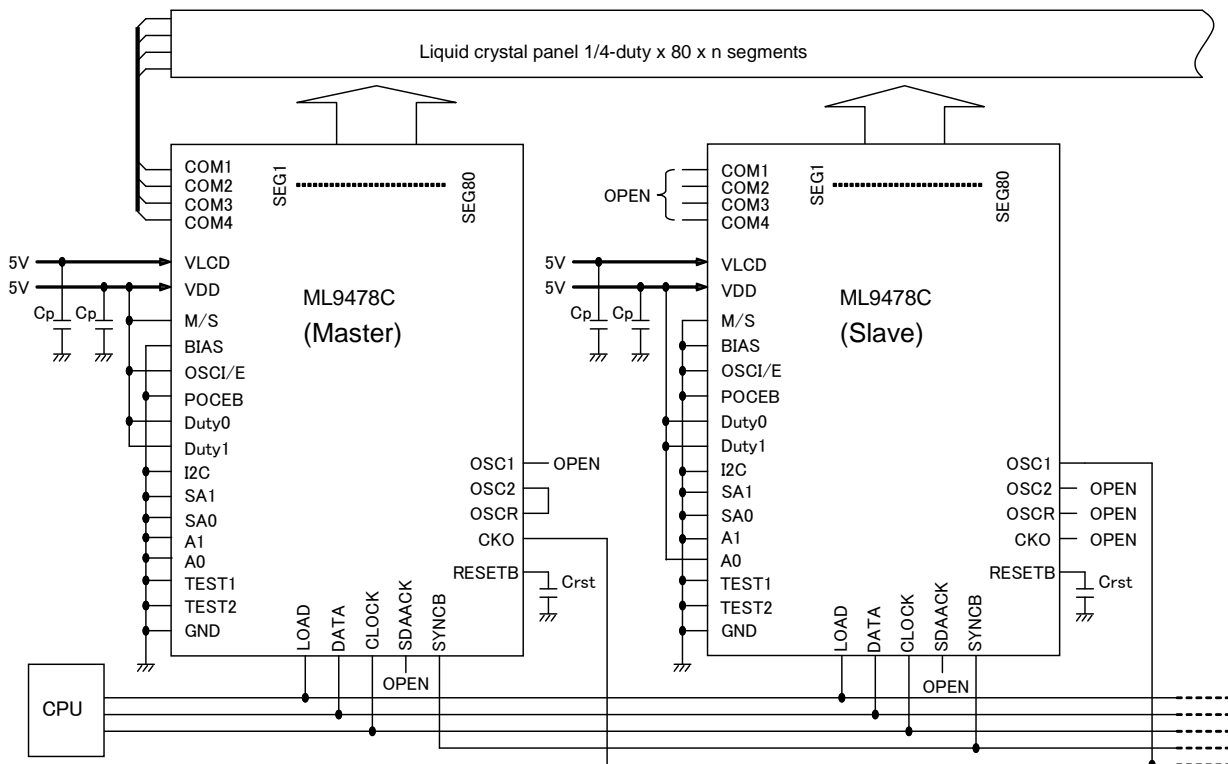

Cascade configuration 2

I²C interface

External Rf-based CR oscillator circuit used

1/4Duty

External RESETB signal input

The common outputs of the slave chip output GND-level. So Com1 to Com4 set to open.

[External component]

C_p = 0.1 [μF] (bypass capacitor between power supplies),

R_f = 470 [kΩ] (external R, resistor for CR oscillator circuit),

R_{up} = Resistor for SDA data bus pull-up

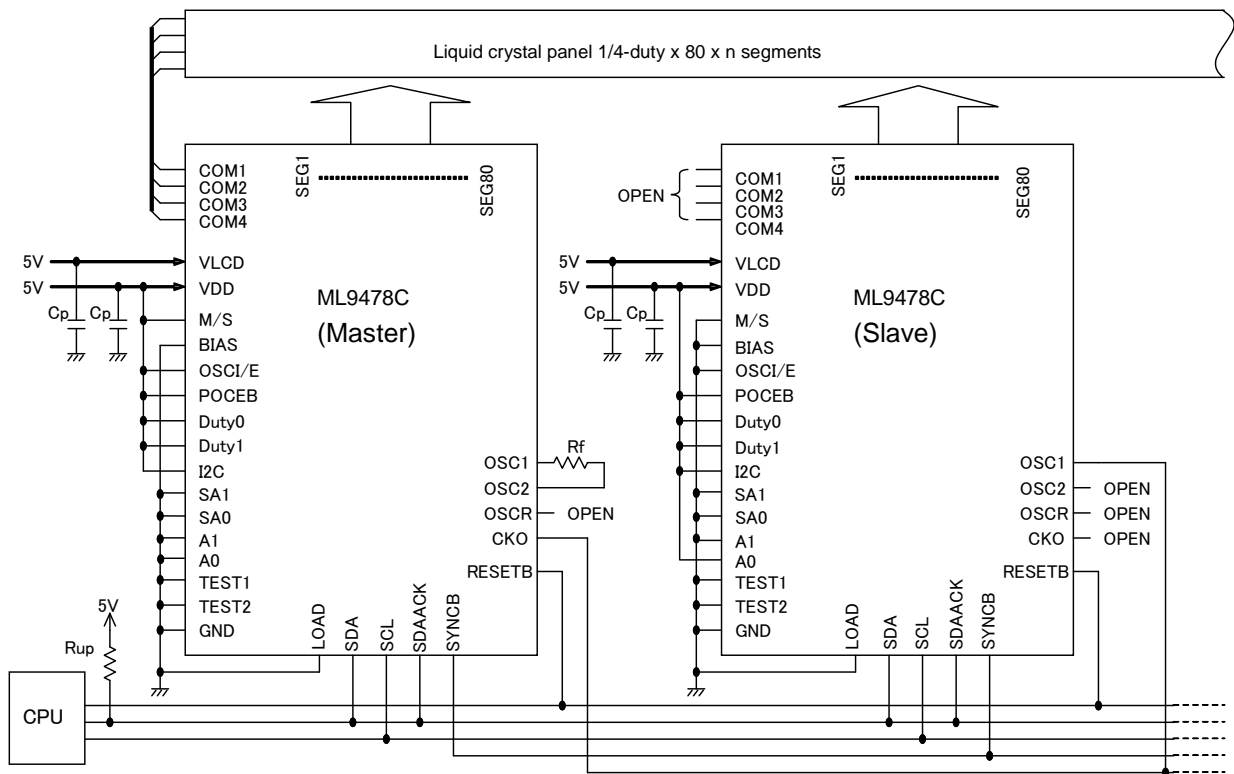

PAD CONFIGURATION

Pad layout (pattern face)

Chip size : 4.80 mm x 0.90 mm
 Chip thickness : 400 μm ± 20 μm
 Minimum bump pitch : 50 μm
 Bump height : 15 μm ± 3 μm

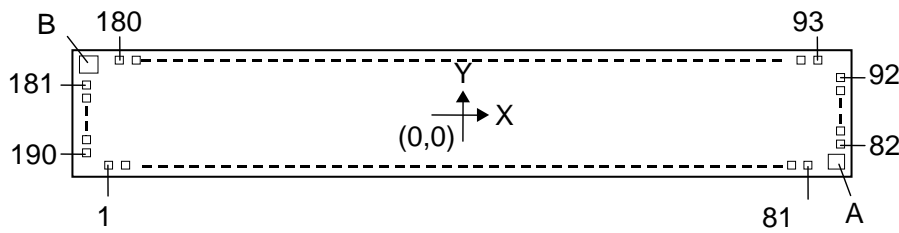

Bump and alignment mark dimensions (pattern face)

PAD No.1~81 : 32 μm x 80 μm
 PAD No.82~190 : 30 μm x 84 μm
 Alignment marks A and B : See below

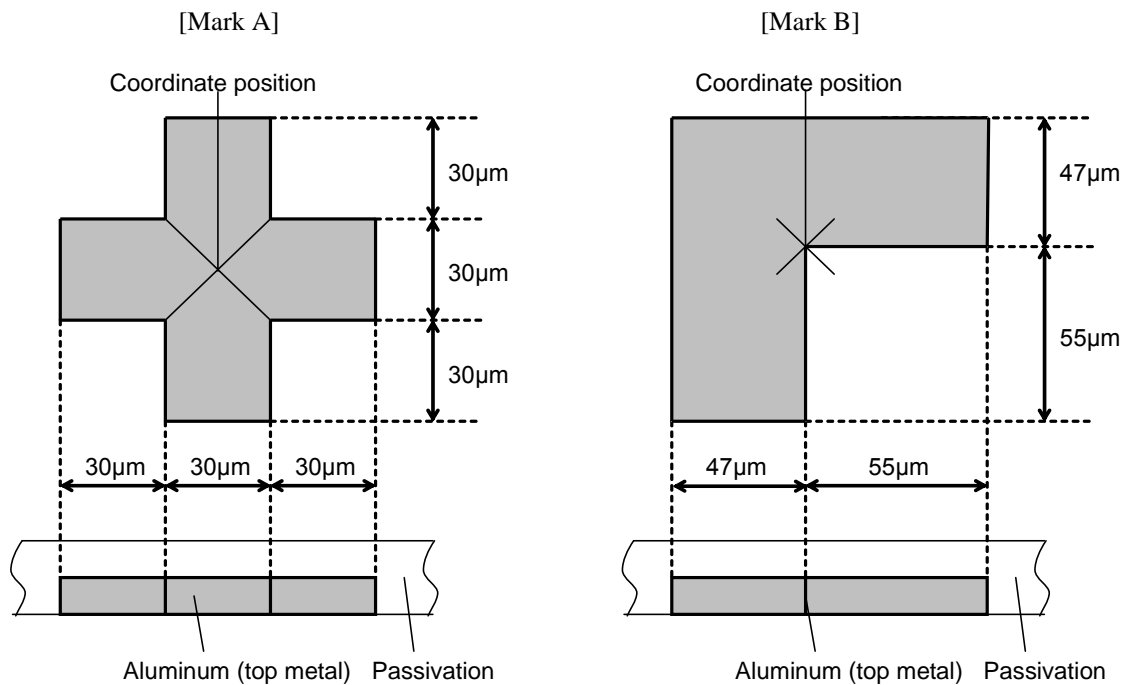

Alignment mark	X-coordinate (μm)	Y-coordinate (μm)
Mark A	2289	-308
Mark B	-2289	309

Pad center coordinates

Pad number	Pad name	X-coordinate (μm)	Y-coordinate (μm)	Pad number	Pad name	X-coordinate (μm)	Y-coordinate (μm)
1	DUMMY	-2206	-308	41	VLCD	27	-308
2	DUMMY	-2149	-308	42	VLCD	81	-308
3	GNDO	-2092	-308	43	VLCD	135	-308
4	Duty1	-2035	-308	44	RESETB	192	-308
5	Duty1	-1978	-308	45	RESETB	244	-308
6	Duty0	-1921	-308	46	OSC1	298	-308
7	Duty0	-1869	-308	47	OSC1	350	-308
8	A0	-1815	-308	48	OSC1	404	-308
9	A0	-1763	-308	49	OSC2	458	-308
10	A1	-1709	-308	50	OSC2	510	-308
11	A1	-1657	-308	51	OSC2	564	-308
12	SA0	-1603	-308	52	OSC2	618	-308
13	SA0	-1549	-308	53	OSCR	672	-308
14	SA1	-1492	-308	54	OSCR	724	-308
15	SA1	-1436	-308	55	OSCR	776	-308
16	VDDO	-1379	-308	56	CKO	830	-308
17	SDAACK	-1322	-308	57	CKO	882	-308
18	SDAACK	-1265	-308	58	CKO	934	-308
19	SDAACK	-1208	-308	59	CKO	986	-308
20	DATA(SDA)	-1151	-308	60	SYNCB	1040	-308
21	DATA(SDA)	-1094	-308	61	SYNCB	1092	-308
22	CLOCK(SCL)	-1037	-308	62	SYNCB	1144	-308
23	CLOCK(SCL)	-980	-308	63	SYNCB	1196	-308
24	LOAD	-923	-308	64	VDDO	1250	-308
25	LOAD	-866	-308	65	I2C	1304	-308
26	GND	-809	-308	66	I2C	1356	-308
27	GND	-752	-308	67	M/S	1413	-308
28	GND	-695	-308	68	M/S	1465	-308
29	GND	-638	-308	69	POCEB	1522	-308
30	GND	-581	-308	70	POCEB	1574	-308
31	GND	-524	-308	71	OSCI/E	1628	-308
32	VDD	-467	-308	72	OSCI/E	1680	-308
33	VDD	-412	-308	73	BIAS	1737	-308
34	VDD	-357	-308	74	BIAS	1789	-308
35	VDD	-302	-308	75	TEST2	1846	-308
36	VDD	-247	-308	76	TEST2	1900	-308
37	VDD	-192	-308	77	TEST1	1957	-308
38	VLCD	-135	-308	78	TEST1	2014	-308
39	VLCD	-81	-308	79	GNDO	2071	-308
40	VLCD	-27	-308	80	DUMMY	2128	-308

ML9478C

Pad number	Pad name	X-coordinate (μm)	Y-coordinate (μm)	Pad number	Pad name	X-coordinate (μm)	Y-coordinate (μm)
81	DUMMY	2185	-308	125	SEG31	585	309
82	DUMMY	2289	-232	126	SEG32	535	309
83	DUMMY	2289	-182	127	SEG33	485	309
84	DUMMY	2289	-132	128	SEG34	435	309
85	COM1	2289	-82	129	SEG35	385	309
86	COM2	2289	-32	130	SEG36	335	309
87	COM3	2289	18	131	SEG37	285	309
88	COM4	2289	68	132	SEG38	235	309
89	DUMMY	2289	118	133	SEG39	185	309
90	DUMMY	2289	168	134	SEG40	135	309
91	DUMMY	2289	218	135	COM1	85	309
92	DUMMY	2289	268	136	COM2	35	309
93	DUMMY	2185	309	137	COM3	-15	309
94	DUMMY	2135	309	138	COM4	-65	309
95	SEG1	2085	309	139	SEG41	-115	309
96	SEG2	2035	309	140	SEG42	-165	309
97	SEG3	1985	309	141	SEG43	-215	309
98	SEG4	1935	309	142	SEG44	-265	309
99	SEG5	1885	309	143	SEG45	-315	309
100	SEG6	1835	309	144	SEG46	-365	309
101	SEG7	1785	309	145	SEG47	-415	309
102	SEG8	1735	309	146	SEG48	-465	309
103	SEG9	1685	309	147	SEG49	-515	309
104	SEG10	1635	309	148	SEG50	-565	309
105	SEG11	1585	309	149	SEG51	-615	309
106	SEG12	1535	309	150	SEG52	-665	309
107	SEG13	1485	309	151	SEG53	-715	309
108	SEG14	1435	309	152	SEG54	-765	309
109	SEG15	1385	309	153	SEG55	-815	309
110	SEG16	1335	309	154	SEG56	-865	309
111	SEG17	1285	309	155	SEG57	-915	309
112	SEG18	1235	309	156	SEG58	-965	309
113	SEG19	1185	309	157	SEG59	-1015	309
114	SEG20	1135	309	158	SEG60	-1065	309
115	SEG21	1085	309	159	SEG61	-1115	309
116	SEG22	1035	309	160	SEG62	-1165	309
117	SEG23	985	309	161	SEG63	-1215	309
118	SEG24	935	309	162	SEG64	-1265	309
119	SEG25	885	309	163	SEG65	-1315	309
120	SEG26	835	309	164	SEG66	-1365	309
121	SEG27	785	309	165	SEG67	-1415	309
122	SEG28	735	309	166	SEG68	-1465	309
123	SEG29	685	309	167	SEG69	-1515	309
124	SEG30	635	309	168	SEG70	-1565	309

REVISION HISTORY

Document No.	Issue Date	Page		Description
		Previous Edition	New Edition	
FEDL9478C-01	Apr .25,2012	–	–	Final edition 1 issued
FEDL9478C-02	Dec.18.2017	P4	P4	Add VIH/VIL applicable pin :RESETB
		P14	P14	Add Display off comment and timing
		P24	P24	Add Power ON/OFF sequence

Notes

- 1) The information contained herein is subject to change without notice.
- 2) Although LAPIS Semiconductor is continuously working to improve product reliability and quality, semiconductors can break down and malfunction due to various factors. Therefore, in order to prevent personal injury or fire arising from failure, please take safety measures such as complying with the derating characteristics, implementing redundant and fire prevention designs, and utilizing backups and fail-safe procedures. LAPIS Semiconductor shall have no responsibility for any damages arising out of the use of our Products beyond the rating specified by LAPIS Semiconductor.
- 3) Examples of application circuits, circuit constants and any other information contained herein are provided only to illustrate the standard usage and operations of the Products. The peripheral conditions must be taken into account when designing circuits for mass production.
- 4) The technical information specified herein is intended only to show the typical functions of the Products and examples of application circuits for the Products. No license, expressly or implied, is granted hereby under any intellectual property rights or other rights of LAPIS Semiconductor or any third party with respect to the information contained in this document; therefore LAPIS Semiconductor shall have no responsibility whatsoever for any dispute, concerning such rights owned by third parties, arising out of the use of such technical information.
- 5) The Products are intended for use in general electronic equipment (i.e. AV/OA devices, communication, consumer systems, gaming/entertainment sets) as well as the applications indicated in this document.
- 6) The Products specified in this document are not designed to be radiation tolerant.
- 7) For use of our Products in applications requiring a high degree of reliability (as exemplified below), please contact and consult with a LAPIS Semiconductor representative: transportation equipment (i.e. cars, ships, trains), primary communication equipment, traffic lights, fire/crime prevention, safety equipment, medical systems, servers, solar cells, and power transmission systems.
- 8) Do not use our Products in applications requiring extremely high reliability, such as aerospace equipment, nuclear power control systems, and submarine repeaters.
- 9) LAPIS Semiconductor shall have no responsibility for any damages or injury arising from non-compliance with the recommended usage conditions and specifications contained herein.
- 10) LAPIS Semiconductor has used reasonable care to ensure the accuracy of the information contained in this document. However, LAPIS Semiconductor does not warrant that such information is error-free and LAPIS Semiconductor shall have no responsibility for any damages arising from any inaccuracy or misprint of such information.
- 11) Please use the Products in accordance with any applicable environmental laws and regulations, such as the RoHS Directive. For more details, including RoHS compatibility, please contact a ROHM sales office. LAPIS Semiconductor shall have no responsibility for any damages or losses resulting non-compliance with any applicable laws or regulations.
- 12) When providing our Products and technologies contained in this document to other countries, you must abide by the procedures and provisions stipulated in all applicable export laws and regulations, including without limitation the US Export Administration Regulations and the Foreign Exchange and Foreign Trade Act.
- 13) This document, in part or in whole, may not be reprinted or reproduced without prior consent of LAPIS Semiconductor.

Copyright 2017 LAPIS Semiconductor Co., Ltd.

LAPIS Semiconductor Co., Ltd.

2-4-8 Shinyokohama, Kouhoku-ku,
Yokohama 222-8575, Japan
<http://www.lapis-semi.com/en/>