

DESCRIPTION

This family is a 16M bit dynamic RAM organized 4,194,304 x 4-bit configuration with Extended Data Out mode CMOS DRAMs. Extended data out mode is a kind of page mode which is useful for the read operation. The circuit and process design allow this device to achieve high performance and low power dissipation. Optional features are access time(50, 60 or 70ns) and refresh cycle(2K ref. or 4K ref.) and power consumption (Normal or Low power with self refresh). Hyundai's advanced circuit design and process technology allow this device to achieve high bandwidth, low power consumption and high reliability.

FEATURES

- Extended data out operation
- Read-modify-write Capability
- TTL compatible inputs and outputs
- /CAS-before-/RAS, /RAS-only, Hidden and Self refresh capability
- JEDEC standard pinout
- 24/26-pin Plastic SOJ (300mil)
24/26-pin Plastic TSOP-II (300mil)
- Single power supply of 5V ± 10%
- Early write or output enable controlled write
- Max. Active power dissipation
- Fast access time and cycle time

Speed	2K refresh	4K refresh
50	798mW	605mW
60	660mW	495mW
70	550mW	440mW

Speed	tRAC	tCAC	tHPC
50	50ns	13ns	20ns
60	60ns	15ns	25ns
70	70ns	18ns	30ns

- Refresh cycle

Part number	Refresh	Normal	SL-part
HY5117404C	2K	32ms	256ms
HY5116404C	4K	64ms	

ORDERING INFORMATION

Part Name	Refresh	Power	Package
HY5117404CJ	2K		24/26Pin SOJ
HY5117404CSLJ	2K	SL-part	24/26Pin SOJ
HY5117404CT	2K		24/26Pin TSOP-II
HY5117404CSLT	2K	SL-part	24/26Pin TSOP-II
HY5116404CJ	4K		24/26Pin SOJ
HY5116404CSLJ	4K	SL-part	24/26Pin SOJ
HY5116404CT	4K		24/26Pin TSOP-II
HY5116404CSLT	4K	SL-part	24/26Pin TSOP-II

*SL : Low power with self refresh

FUNCTIONAL BLOCK DIAGRAM

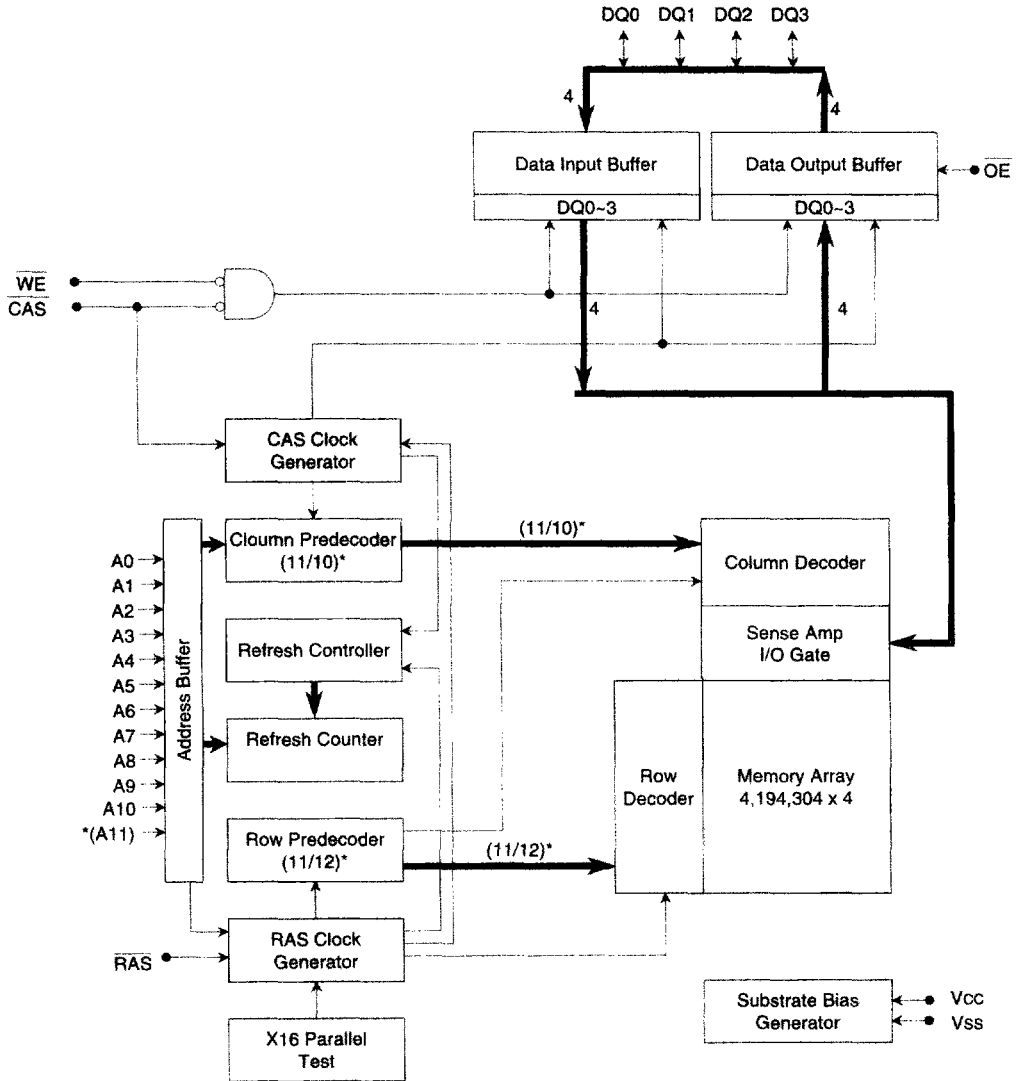

*(A11) for 4K refresh part
(2K Refresh / 4K Refresh)*

PIN CONFIGURATION (Marking Side)

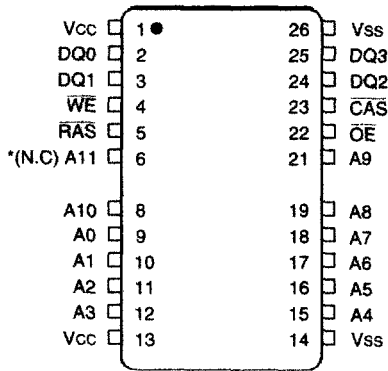

24/26Pin Plastic SOJ (300mil)

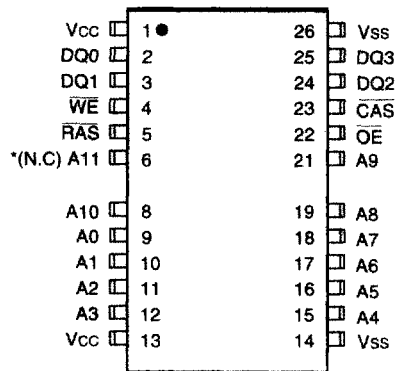

24/26Pin Plastic TSOP-II (300mil)

(N.C)* : For 2K refresh product

PIN DESCRIPTION

Pin Name	Parameter
/RAS	Row Address Strobe
/CAS	Column Address Strobe
/WE	Write Enable
/OE	Output Enable
A0-A11	Address Input (4K Refresh Product)
A0-A10	Address Input (2K Refresh Product)
DQ0-DQ3	Data In/Out
Vcc	Power (5V)
Vss	Ground
NC	No Connection

ABSOLUTE MAXIMUM RATING

Symbol	Parameter	Rating	Unit
T _A	Ambient Temperature	0 to 70	°C
T _{STG}	Storage Temperature	-55 to 150	°C
V _{IN} , V _{OUT}	Voltage on Any Pin relative to V _{SS}	-1.0 to 7.0	V
V _{CC}	Voltage on V _{CC} relative to V _{SS}	-1.0 to 7.0	V
I _{OS}	Short Circuit Output Current	50	mA
P _D	Power Dissipation	1	W
T _{SOLDER}	Soldering Temperature · Time	260 · 10	°C · sec

Note : Operation at or above Absolute Maximum Ratings can adversely affect device reliability

RECOMMENDED DC OPERATING CONDITIONS

(T_A = 0°C to 70°C)

Symbol	Parameter	Min	Typ	Max	UNIT
V _{CC}	Power Supply Voltage	4.5	5.0	5.5	V
V _{IH}	Input High Voltage	2.4	-	V _{CC} +1.0	V
V _{IL}	Input Low Voltage	-1.0	-	0.8	V

Note : All voltages are referenced to V_{SS}.

DC OPERATING CHARACTERISTIC

Symbol	Parameter	Test condition	Min	Max	Unit
I _{LI}	Input Leakage Current (Any input)	V _{SS} ≤ V _{IN} ≤ V _{CC} - 1.0 All other pins not under test = V _{SS}	-10	10	μA
I _{LO}	Output Leakage Current (Any input)	V _{SS} ≤ V _{OUT} ≤ V _{CC} /RAS & /CAS at V _{IH}	-10	10	μA
V _{OL}	Output Low Voltage	I _{OL} = 4.2mA	-	0.4	V
V _{OH}	Output High Voltage	I _{OH} = -5.0mA	2.4	-	V

DC CHARACTERISTICS

(TA = 0°C to 70°C, Vcc = 5V ± 10%, Vss = 0V, unless otherwise noted.)

Symbol	Parameter	Test condition	Speed	Max. Current		Unit
				2K Ref	4K Ref	
Icc1	Operating Current	/RAS, /CAS Cycling tRC = tRC(min.)	50	145	110	mA
			60	120	90	
			70	100	80	
Icc2	TTL Standby Current	/RAS, /CAS ≥ VIH Other inputs ≥ Vss	SL-part	2 1	2 1	mA
Icc3	/RAS-only Refresh Current	/RAS Cycling, /CAS = VIH tRC = tRC(min.)	50	145	110	mA
			60	120	90	
			70	100	80	
Icc4	EDO mode Current	/CAS Cycling, /RAS = VIL tHPC = tHPC(min.)	50	120	90	mA
			60	100	80	
			70	80	70	
Icc5	CMOS Standby Current	/RAS = /CAS ≥ Vcc - 0.2V	SL-part	1 300	1 300	mA μA
Icc6	/CAS-before-/RAS Refresh Current	/RAS & /CAS = 0.2V tRC = tRC(min.)	50	145	110	mA
			60	120	90	
			70	100	80	
Icc7	Battery Back-up Current (SL-part)	tRC=125μs (2K Ref), 62.5μs (4K Ref) /CAS = CBR cycling or 0.2V /OE & /WE = Vcc - 0.2V Address = Vcc-0.2V or 0.2V DQ0-DQ3 = Vcc-0.2, 0.2V or Open	tRAS ≤ 300ns	300	300	μA
			tRAS ≤ 1μs	500	500	
Icc8	Self Refresh Current (SL-part)	/RAS & /CAS = 0.2V Other pins are same as Icc7		300	300	μA

Note

- Icc1, Icc3, Icc4 and Icc6 depend on output loading and cycle rates(tRC and tHPC).
- Specified values are obtained with output unloaded.
- Icc is specified as an average current. In Icc1, Icc3, Icc6, address can be changed only once while /RAS=VIL. In Icc4, address can be changed maximum once while /CAS=VIH within one EDO mode cycle time tHPC.
- Only /RAS(max.) = 1μs is applied to refresh of battery backup but tRAS(max.) = 10μs is to applied to normal functional operation.
- Icc5(max.) = 300μA, Icc7 and Icc8 are applied to SL-part only.

AC CHARACTERISTICS

(TA = 0 °C to 70 °C, VCC = 5V ± 10% , VSS = 0V, unless otherwise noted.)

Symbol	Parameter	50ns		60ns		70ns		Unit	Note
		Min	Max	Min	Max	Min	Max		
tRC	Random read or write cycle time	84	-	104	-	124	-	ns	
tRWC	Read-modify-write cycle time	113	-	137	-	160	-	ns	
tHPC	EDO mode cycle time	20	-	25	-	30	-	ns	2
tHPRWC	EDO mode read-modify-write cycle time	61	-	70	-	78	-	ns	2
tRAC	Access time from /RAS	-	50	-	60	-	70	ns	5,6,7
tCAC	Access time from /CAS	-	13	-	15	-	18	ns	5,6
tAA	Access time from column address	-	25	-	30	-	35	ns	5
tCPA	Access time from column precharge	-	30	-	35	-	40	ns	5
tCLZ	/CAS to output low impedance	3	-	3	-	3	-	ns	5
tCEZ	Output buffer turn-off delay from /CAS	3	13	3	15	3	18	ns	8
tT	Transition time(rise and fall)	2	50	2	50	2	50	ns	3
tRP	/RAS precharge time	30	-	40	-	50	-	ns	
tRAS	/RAS pulse width	50	10K	60	10K	70	10K	ns	
tRASP	/RAS pulse width(EDO mode)	50	200K	60	200K	70	200K	ns	
tRSH	/RAS hold time	13	-	15	-	18	-	ns	
tCSH	/CAS hold time	40	-	45	-	50	-	ns	
tCAS	/CAS pulse width	8	10K	11	10K	14	10K	ns	
tRCD	/RAS to /CAS delay time	18	37	20	45	20	52	ns	6
tRAD	/RAS to column address delay time	10	25	15	30	15	35	ns	7
tCRP	/CAS to /RAS precharge time	5	-	5	-	5	-	ns	11
tCP	/CAS precharge time	8	-	10	-	12	-	ns	
tASR	Row address set-up time	0	-	0	-	0	-	ns	
tRAH	Row address hold time	8	-	10	-	10	-	ns	
tASC	Column address set-up time	0	-	0	-	0	-	ns	
tCAH	Column address hold time	10	-	10	-	10	-	ns	
tRAL	Column address to /RAS lead time	25	-	30	-	35	-	ns	
tRCS	Read command set-up time	0	-	0	-	0	-	ns	
tRCH	Read command hold time referenced to /CAS	0	-	0	-	0	-	ns	9
tRRH	Read command hold time referenced to /RAS	0	-	0	-	0	-	ns	9
tWCH	Write command hold time	8	-	10	-	10	-	ns	
tWP	Write command pulse width	8	-	10	-	10	-	ns	
tRWL	Write command to /RAS lead time	10	-	12	-	12	-	ns	
tCWL	Write command to /CAS lead time	10	-	12	-	12	-	ns	

AC CHARACTERISTICS

Continued

Symbol	Parameter	50ns		60ns		70ns		Unit	Note
		Min	Max	Min	Max	Min	Max		
tDS	Data-in set-up time	0	-	0	-	0	-	ns	10
tDH	Data-in hold time		-	10	-	10	-	ns	10
tREF	Refresh period(2048 cycles)	-	32	-	32	-	32	ms	
	Refresh period(4096 cycles)	-	64	-	64	-	64	ms	
	Refresh period(SL-part)	-	256	-	256	-	256	ms	
tWCS	Write command set-up time	0	-	0	-	0	-	ns	11
tCWD	/CAS to /WE delay time	30	-	34	-	40	-	ns	11
tRWD	/RAS to /WE delay time	67	-	79	-	92	-	ns	11
tAWD	Column address to /WE delay time	42	-	49	-	57	-	ns	11
tCSR	/CAS set-up time(CBR cycle)	5	-	5	-	5	-	ns	
tCHR	/CAS hold time(CBR cycle)	10	-	10	-	10	-	ns	
tRPC	/RAS to /CAS precharge time	5	-	5	-	5	-	ns	
tCPT	/CAS precharge time(CBR counter test)	15	-	20	-	25	-	ns	
tROH	/RAS hold time referenced to /OE	10	-	10	-	10	-	ns	
tOEA	/OE access time	-	13	-	15	-	18	ns	
tOED	/OE to data delay time	13	-	15	-	18	-	ns	
tOEZ	Output buffer turn-off delay time from /OE	3	13	3	15	3	18	ns	8
tOEH	/OE command hold time	13	-	15	-	18	-	ns	
tCPWD	/WE delay time from /CAS precharge	47	-	54	-	62	-	ns	11
tRHCP	/RAS hold time from /CAS precharge	30	-	35	-	40	-	ns	
tWRP	/WE to /RAS precharge time(CBR cycle)	10	-	10	-	10	-	ns	
tWRH	/WE to /RAS hold time(CBR cycle)	10	-	10	-	10	-	ns	
tRASS	/RAS pulse width(self refresh)	100K	-	100K	-	100K	-	ns	
tRPS	/RAS Precharge Time (Self refresh)	90	-	110	-	130	-	ns	
tCHS	/CAS Hold Time (Self refresh)	-50	-	-50	-	-50	-	ns	
tDOH	Output Data Hold Time	5	-	5	-	5	-	ns	
tREZ	Output Buffer Turn Off Delay Time from /RAS	3	13	3	15	3	18	ns	
tWEZ	Output Buffer Turn Off Delay Time from /WE	3	13	3	15	3	18	ns	
tWED	/WE to Data Delay Time	13	-	15	-	18	-	ns	
tOEP	/OE Precharge Time	5	-	5	-	5	-	ns	
tWPE	/WE Pulse Width (EDO cycle)	5	-	5	-	5	-	ns	
tOCH	/OE to /CAS Hold Time	5	-	5	-	5	-	ns	
tCHO	/CAS Hold Time to /OE	5	-	5	-	5	-	ns	

TEST MODE

Symbol	Parameter	50ns		60ns		70ns		Unit	Note
		Min	Max	Min	Max	Min	Max		
tRC	Random read or write cycle time	89	-	109	-	129	-	ns	
tRWC	Read-modify-write cycle time	118	-	142	-	165	-	ns	
tHPC	EDO mode cycle time	25	-	30	-	35	-	ns	2
tHPRWC	EDO mode read-modify-write cycle time	66	-	75	-	83	-	ns	2
tRAC	Access time from /RAS	-	55	-	65	-	75	ns	5,6,7
tCAC	Access time from /CAS	-	18	-	20	-	23	ns	5,6
tAA	Access time from column address	-	30	-	35	-	40	ns	5,7
tCPA	Access time from column precharge	-	35	-	40	-	45	ns	5
tRAS	/RAS pulse width	55	10K	65	10K	75	10K	ns	
tRASP	/RAS pulse width(EDO mode)	55	200K	65	200K	75	200K	ns	
tRSH	/RAS hold time	18	-	20	-	23	-	ns	
tCSH	/CAS hold time	45	-	50	-	55	-	ns	
tCAS	/CAS pulse width	13	10K	16	10K	19	10K	ns	
tRAL	Column address to /RAS lead time	30	-	35	-	40	-	ns	
tCWD	/CAS to /WE delay time	35	-	39	-	45	-	ns	11
tRWD	/RAS to /WE delay time	72	-	84	-	97	-	ns	11
tAWD	Column address to /WE delay time	47	-	54	-	62	-	ns	11
tOEA	/OE access time	-	18	-	20	-	23	ns	
tOED	/OE to data delay Time	18	-	20	-	23	-	ns	
tOEH	/OE command hold time	18	-	20	-	23	-	ns	
tCPWD	/WE delay time from /CAS precharge	52	-	59	-	67	-	ns	11

In test mode, data are written into 16 sectors (each is composed of 1M bits) in parallel and retrieved the same way. Column address A0 and A1 are not used. If, upon reading, 4-bit data from 4sectors connected to one DQ pin are equal (all '1's or '0's), the DQ pin indicates a '1'. If they are not equal, the DQ indicates a '0'. The 4Mx4 DRAM can be tested in the same way as a 1Mx4 DRAM is tested.

/WE (when in /CAS-before-/RAS cycle) puts the 4Mx4 DRAM into Test Mode and a /CAS-before-/RAS or a /RAS-only refresh cycle put it back into Normal Mode. /WE (when in /CAS-before-/RAS cycle) shall be used for the refresh operation in the test mode. The test mode function reduces test time(1/4 in case of N test pattern).

NOTE

1. An initial pause of 200 μ s is required after power-up followed by 8 /RAS only refresh cycles before proper device operation is achieved. In case of using internal refresh counter, a minimum of 8 CBR refresh cycles instead of 8 /RAS-only refresh cycles are required.
2. $t_{ASC} \geq t_{CP}(\min)$, assume $t_t=2ns$.
3. $V_{IH}(\min.)$ and $V_{IL}(\max.)$ are reference levels for measuring timing of input signals. Transition times are measured between $V_{IH}(\min.)$ and $V_{IL}(\max.)$
4. The minimum specifications are used only to indicate cycle time at which proper operation over the full temperature range ($T_A=0$ to $70^\circ C$) is assured.
5. Measured at $V_{OH}=2.0V$ and $V_{OL}=0.8V$ with a load equivalent to 2TTL loads and 100pF.
6. Operation within the $t_{RCD}(\max.)$ limit ensures that $t_{RAC}(\max.)$ can be met. $t_{RCD}(\max.)$ is specified as a reference point only. If t_{RCD} is greater than the specified $t_{RCD}(\max.)$ limit, then access time is controlled by t_{CAC} .
7. Operation within the $t_{RAD}(\max.)$ limit ensures that $t_{RAC}(\max.)$ can be met. $t_{RAD}(\max.)$ is specified as a reference point only. If t_{RAD} is greater than the specified $t_{RAD}(\max.)$ limit, then access time is controlled by t_{AA} .
8. t_{WEZ} , t_{REZ} , t_{CEZ} and t_{OEZ} define the time at which the output achieves the open circuit condition and is not referenced to output voltage levels.
9. Either t_{RCH} or t_{RRH} must be satisfied for a read cycle.
10. These parameters are referenced to /CAS leading edge in early write cycles and to /WE leading edge in read-modify-write cycles.
11. t_{WCS} , t_{RWD} , t_{CWD} , t_{AWD} and t_{CPWD} are not restrictive operating parameters. They are included in the data sheet as electrical characteristics only. If $t_{WCS} \geq t_{WCS}(\min.)$, the cycle is an early write cycle and data out pin will remain open circuit (high impedance) through the entire cycle. If $t_{RWD} \geq t_{RWD}(\min.)$, $t_{CWD} \geq t_{CWD}(\min.)$, $t_{AWD} \geq t_{AWD}(\min.)$, and $t_{CPWD} \geq t_{CPWD}(\min.)$, the cycle is a read-modify-write cycle and data out will contain data read from the selected cell. If neither of the above sets of conditions is satisfied, the condition of the data out (at access time) is indeterminate.
12. If /RAS goes to high before /CAS high going, the open circuit condition of the output is achieved by /CAS high going. If /CAS goes to high before /RAS high going, the open circuit condition of the output is achieved by /RAS high going.

CAPACITANCE

($T_A = 25^\circ C$, $V_{CC} = 5V \pm 10\%$, $V_{SS} = 0V$ and $f=1MHz$, unless otherwise noted.)

Symbol	Parameter	Typ.	Max	Unit
CIN1	Input Capacitance (A0-A11)	-	5	pF
CIN2	Input Capacitance (/RAS, /CAS, /WE, /OE)	-	7	pF
CDQ	Data Input / Output Capacitance (DQ0-DQ3)	-	7	pF