

### Octal Bus Buffer

The TC74HC688A is a high speed CMOS 8-Bit EQUALITY COMPARATOR fabricated with silicon gate C<sup>2</sup>MOS technology.

They achieve the high speed operation similar to equivalent LSTTL while maintaining the CMOS low power dissipation.

The TC75HC688A compares two 8-bit binary or BCD words applied inputs P0 ~ P7, and inputs Q0 ~ Q7, and indicates whether or not they are equal.

A signal active low enable is provided to facilitate cascading of several packages to compare of words greater than 8 bits.

All inputs are equipped with protection circuits against static discharge or transient excess voltage.

### Features

- High Speed:  $t_{pd} = 17\text{ns}(\text{Typ.})$  at  $V_{CC} = 5\text{V}$
- Low Power Dissipation:  $I_{CC} = 4\mu\text{A}(\text{Max.})$  at  $T_a = 25^\circ\text{C}$
- High Noise Immunity:  $V_{NIH} = V_{NIL} = 28\% V_{CC} (\text{Min})$
- Output Drive Capability: 10 LSTTL Loads
- Symmetrical Output Impedance:  $|I_{OH}| = I_{OL} = 4\text{mA}(\text{Min.})$
- Balanced Propagation Delays:  $t_{pLH} = t_{pHL}$
- Wide Operating Voltage Range:  $V_{CC}(\text{opr}) = 2\text{V} \sim 6\text{V}$
- Pin and Function Compatible with 74LS688

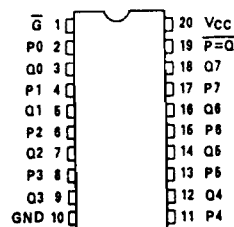
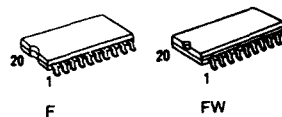
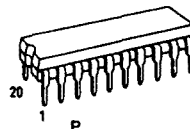

(TOP VIEW)

Pin Assignment

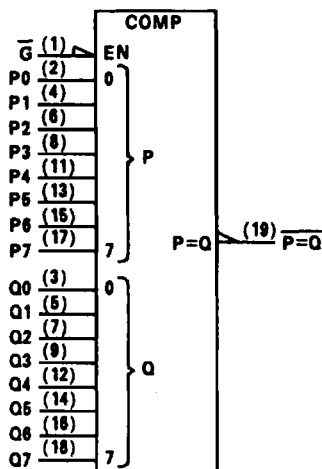

IEC Logic Symbol

### Truth Table

Inputs		Output
P, Q	$\bar{G}$	$P=Q$
$P=Q$	L	L
$P \neq Q$	L	H
X	H	H

X: "Don't Care"

## Absolute Maximum Ratings

Parameter	Symbol	Value	Unit
Supply Voltage Range	$V_{CC}$	-0.5 ~ 7	V
DC Input Voltage	$V_{IN}$	-0.5 - $V_{CC}$ + 0.5	V
DC Output Voltage	$V_{OUT}$	-0.5 - $V_{CC}$ + 0.5	V
Input Diode Current	$I_{IK}$	±20	mA
Output Diode Current	$I_{OK}$	±20	mA
DC Output Current	$I_{OUT}$	±25	mA
DC $V_{CC}$ /Ground Current	$I_{CC}$	±50	mA
Power Dissipation	$P_D$	500(DIP)*180(MFP)	mW
Storage Temperature	$T_{stg}$	-65 ~ 150	°C
Lead Temperature 10sec	$T_L$	300	°C

\*500mW in the range of  $T_a = -40^\circ\text{C} \sim 65^\circ\text{C}$ . From  $T_a = 65^\circ\text{C}$  to  $85^\circ\text{C}$  a derating factor of -10mW/°C shall be applied until 300mW.

## Recommended Operating Conditions

Parameter	Symbol	Value	Unit
Supply Voltage	$V_{CC}$	2 ~ 6	V
Input Voltage	$V_{IN}$	0 - $V_{CC}$	V
Output Voltage	$V_{OUT}$	0 - $V_{CC}$	V
Operating Temperature	$T_{opr}$	-40 ~ 85	°C
Input Rise and Fall Time	$t_r, t_f$	0 ~ 1000( $V_{CC} = 2.0\text{V}$ ) 0 ~ 500( $V_{CC} = 4.5\text{V}$ ) 0 ~ 400( $V_{CC} = 6.0\text{V}$ )	ns

## DC Electrical Characteristics

Parameter	Symbol	Test Condition	$T_a = 25^\circ\text{C}$			$T_a = -40 \sim 85^\circ\text{C}$		Unit		
			$V_{CC}$	Min.	Typ.	Max.	Min.		Max.	
High-Level Input Voltage	$V_{IH}$	-	2.0	1.5	-	-	1.5	-	V	
			4.5	3.15	-	-	3.15	-		
			6.0	4.2	-	-	4.2	-		
Low-Level Input Voltage	$V_{IL}$	-	2.0	-	-	0.5	-	0.5	V	
			4.5	-	-	1.35	-	1.35		
			6.0	-	-	1.8	-	1.8		
High-Level Output Voltage	$V_{OH}$	$V_{IN} = V_{IH}$ or $V_{IL}$	$I_{OH} = -20\mu\text{A}$	2.0	1.9	2.0	-	1.9	-	V
				4.5	4.4	4.5	-	4.4	-	
				6.0	5.9	6.0	-	5.9	-	
Low-Level Output Voltage	$V_{OL}$	$V_{IN} = V_{IH}$ or $V_{IL}$	$I_{OL} = 20\mu\text{A}$	2.0	-	0.0	0.1	-	0.1	V
				4.5	-	0.0	0.1	-	0.1	
				6.0	-	0.0	0.1	-	0.1	
Low-Level Output Voltage	$V_{OL}$	$V_{IN} = V_{IH}$ or $V_{IL}$	$I_{OL} = 6\text{mA}$ $I_{OL} = 7.8\text{mA}$	4.5	-	0.17	0.26	-	0.33	V
				6.0	-	0.18	0.26	-	0.33	
				6.0	-	-	-	-	-	
3-State Output Off-State Current	$I_{OZ}$	$V_{IN} = V_{IH}$ or $V_{IL}$ $V_{OUT} = V_{CC}$ or GND	6.0	-	-	±0.5	-	±5.0	μA	
Input Leakage Current	$I_{IN}$	$V_{IN} = V_{CC}$ or GND	6.0	-	-	±0.1	-	±1.0		
Quiescent Supply Current	$I_{CC}$	$V_{IN} = V_{CC}$ or GND	6.0	-	-	4.0	-	40.0		

**AC Electrical Characteristics ( $C_L = 15\text{pF}$ ,  $V_{CC} = 5\text{V}$ ,  $T_a = 25^\circ\text{C}$ )**

Parameter	Symbol	Test Condition	Min.	Typ.	Max.	Unit
Output Transition Time	$t_{TLH}$ $t_{THL}$	–	–	4	8	ns
Propagation Delay Time ( $P_n$ , $Q_n$ - $P=Q$ )	$t_{PLH}$ $t_{PHL}$	–	–	17	29	
Propagation Delay Time ( $G$ - $P=Q$ )	$t_{PLH}$	–	–	10	18	

**AC Electrical Characteristics ( $C_L = 50\text{pF}$ , Input  $t_r = t_f = 6\text{ns}$ )**

Parameter	Symbol	Test Condition	$T_a = 25^\circ\text{C}$			$T_a = -40 \sim 85^\circ\text{C}$		Unit	
			$V_{CC}$	Min.	Typ.	Max.	Min.		Max.
Output Transition Time	$t_{TLH}$ $t_{THL}$	–	2.0	–	30	75	–	95	ns
			4.5	–	8	15	–	19	
			6.0	–	7	13	–	16	
Propagation Delay Time ( $P_n$ , $Q_n$ - $P=Q$ )	$t_{PLH}$ $t_{PHL}$	–	2.0	–	60	170	–	215	
			4.5	–	21	34	–	43	
			6.0	–	17	29	–	37	
Propagation Delay Time ( $G$ - $P=Q$ )	$t_{PLH}$ $t_{PHL}$	–	2.0	–	40	110	–	140	
			4.5	–	13	22	–	28	
			6.0	–	10	19	–	24	
Input Capacitance	$C_{IN}$	–	–	5	10	–	10	pF	
Power Dissipation Capacitance	$C_{PD}(1)$	–	–	32	–	–	–		

Note (1)  $C_{PD}$  is defined as the value of the internal equivalent capacitance which is calculated from the operating current consumption without load. Average operating current can be obtained by the equation:

$$I_{CC(opp)} = C_{PD} \cdot V_{CC} \cdot f_{IN} + I_{CC}$$

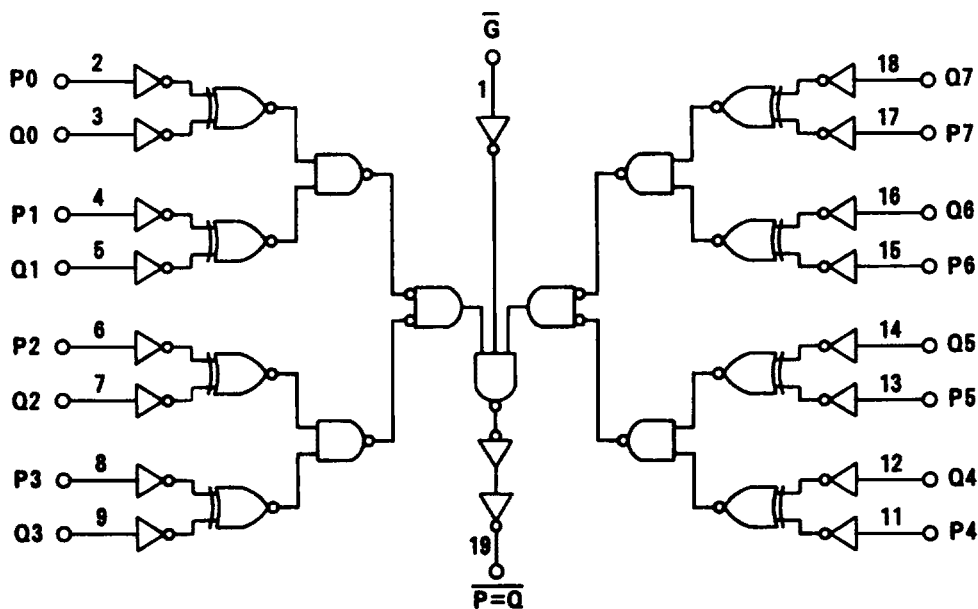

Logic Diagram