

**SPI Real-Time Clock/ Calendar with 5μAh Integrated Backup Power**

**Features**

- Integrated rechargeable solid state battery with power-fail detect and automatic switchover, providing greater than 30 hours of RTC backup
- Smallest commercially available RTC with integrated backup power in compact 5mm x 5mm 1.4mm QFN package
- Temperature compensated charge control
- Integrated EnerChip™ recharged at VDD > 2.5V
- SMT assembly - lead-free reflow solder tolerant
- Real time clock provides year, month, day, week-day, hours, minutes, and seconds based on a 32.768 kHz quartz crystal
- Resolution: seconds to years
- Watchdog functionality
- Freely programmable timer and alarm with interrupt capability
- 3-line SPI-bus with separate, but combinable data input and output
- Integrated oscillator load capacitors for C<sub>L</sub> = 7 pF
- Internal Power-On Reset (POR)
- Open-drain interrupt and clock output pins
- Programmable offset register for frequency adjustment
- Eco-friendly, RoHS compliant - tested

**Applications**

- Wireless sensors and RFID tags
- Power Bridging
- Consumer appliances
- Business and industrial systems
  - (A) Time keeping application
  - (B) Battery powered devices
  - (C) Metering
  - (D) High duration timers
  - (E) Daily alarms
  - (F) Low standby power applications

**Part Numbering Example: CCBC34123 T- A5**

| CCBC34123 | T                              | QFN              | A5              |
|-----------|--------------------------------|------------------|-----------------|
| SERIES    | SHIPPING PKG                   | PACKAGE STYLE    | OPERATING TEMP. |
|           | T = Tube<br>Z1 = 1K<br>Z5 = 5K | QFN = 16-pin QFN | -20°C to +70°C  |

**Electrical Properties**

|                                 |                                 |
|---------------------------------|---------------------------------|
| Minimum VDD to Charge EnerChip: | 2.5V                            |
| Energy Capacity (typical):      | 5μAh                            |
| Recharge time to 80%:           | 10 minutes                      |
| Charge/ Discharge cycles:       | >5000 to 10% depth-of-discharge |

**Physical Properties**

|                        |                   |
|------------------------|-------------------|
| Package size:          | 5mm x 5mm x 1.4mm |
| Operating temperature: | -20°C to +70°C    |
| Storage temperature:   | -40°C to +125°C   |

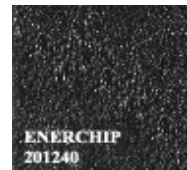

5mm x 5mm x  
1.4mm 16-QFN  
Package

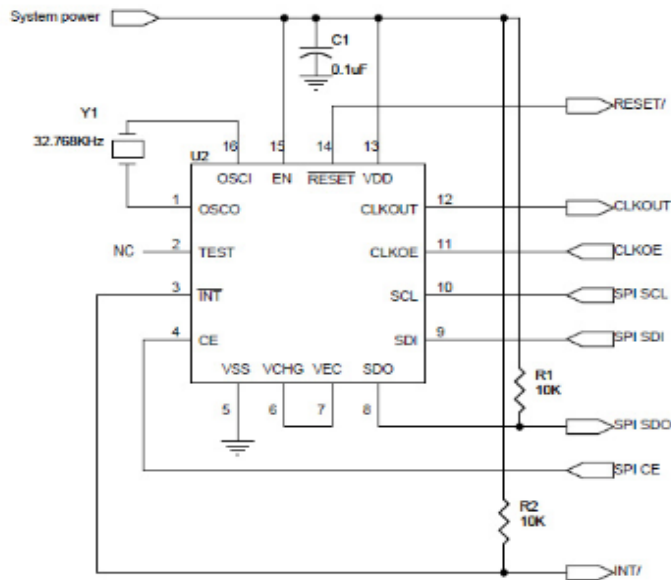

**Figure 1: CCBC34123 Pin-out Diagram**

### General Description

The EnerChip™ RTC CBC34123-M5C combines a Real-Time Clock (RTC) and calendar optimized for low power applications with an integrated rechargeable solid state backup battery and all power management functions. The EnerChip™ RTC ensures a seamless transition from main power to backup power in the event of power loss. The integrated power management circuit ensures thousands of charge-discharge cycles from the integrated EnerChip™ and manages battery charging, discharge cutoff, power switchover, and temperature compensation to maximize the service life of the device. The CCBC34123 provides greater than 30 hours of backup time in the event main power is interrupted. Typical blackout times are less than 4 hours. The EnerChip™ has extremely low self-discharge, recharges quickly, is non-flammable, and RoHS-compliant. The EnerChip™ is charged automatically anytime VDD is above 2.5V.

Data is transferred serially via a Serial Peripheral Interface (SPI-bus) with a maximum data rate of 6.25 Mbit/s. Alarm and timer functions provide the option to generate a wake-up signal on an interrupt pin. An offset register allows fine tuning of the clock.

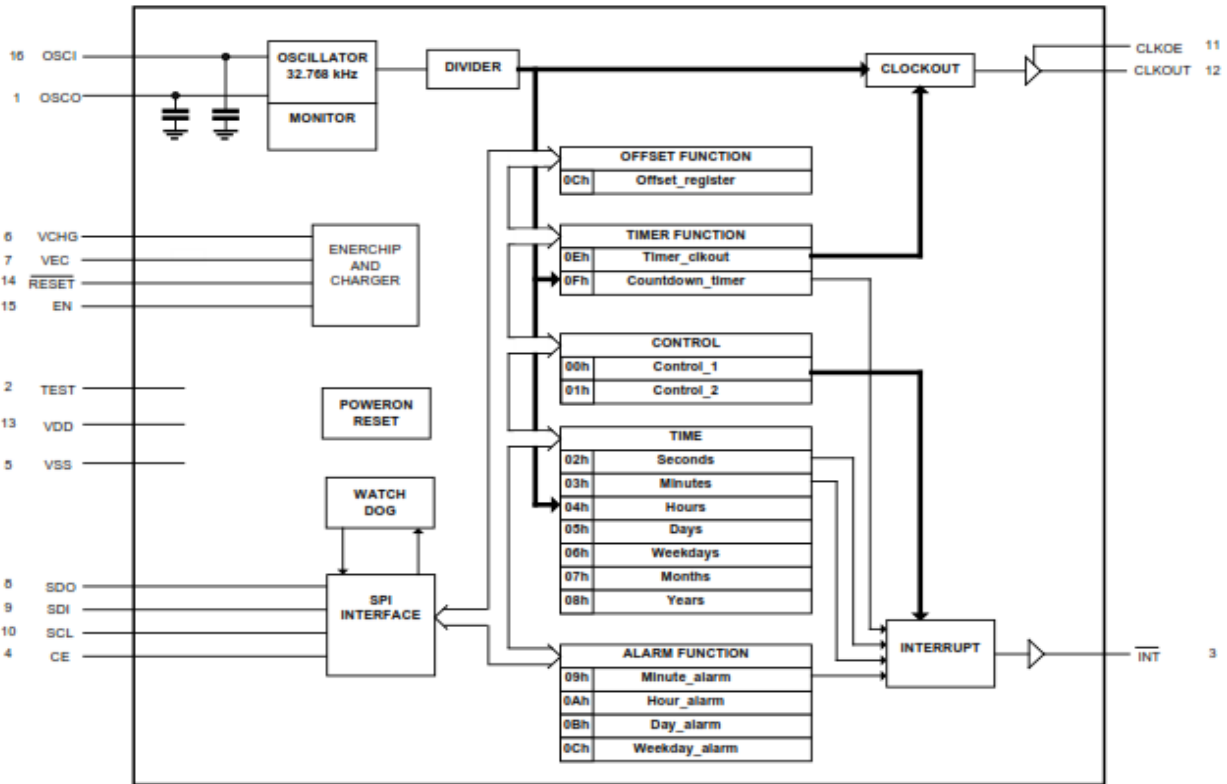

Figure 2: CCBC34123 Block Diagram with Registers

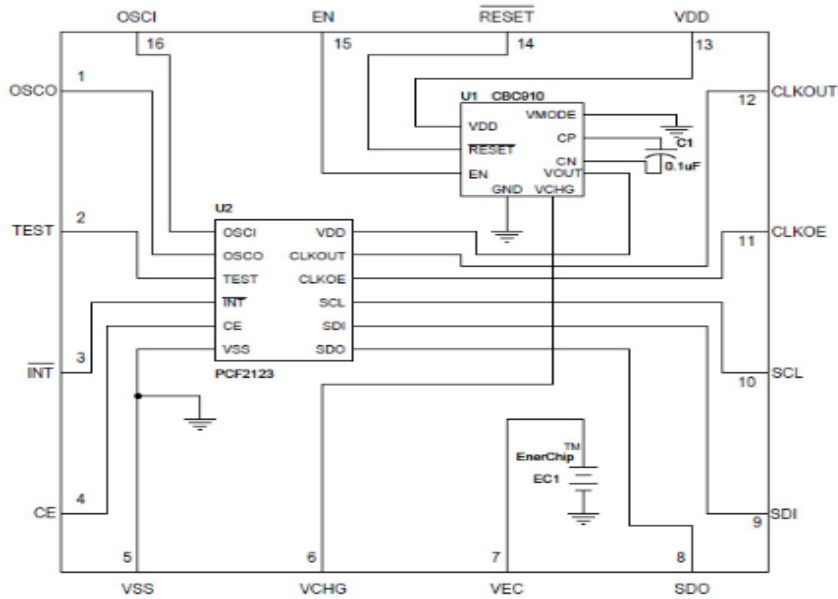

Figure 3: Internal Schematic of CBC34123 EnerChip™ RTC

## CCBC34123-RTC Input/Output Descriptions

| Pin Number | Label  | Description   |
|------------|--------|---|
| 1          | OSCO   | Oscillator output; high-impedance node; minimize wire length between quartz and package   |
| 2          | TEST   | Test pin; not user accessible; connect to VSS or leave floating (internally pulled down)  |
| 3          | INT/   | Interrupt output (open-drain; active LOW)   |
| 4          | CE     | Chip enable input (active HIGH) with internal pull down   |
| 5          | VSS    | Ground  |
| 6          | VCHG   | 4.1V (typical) charging source - connect to VBAT and/or optional EnerChip(s)  |
| 7          | VEC    | Positive terminal of integrated thin film battery - connect to VCHG and nothing else  |
| 8          | SDO    | Serial data output, push-pull; high-impedance when not driving; can be connected to SDI for single wire data line                                 |
| 9          | SDI    | Serial data input; may float when CE is inactive  |
| 10         | SCL    | Serial clock input; may float when CE is inactive   |
| 11         | CLKOE  | CLKOUT enable or disable pin; enable is active HIGH; connect to VSS for low power operation   |
| 12         | CLKOUT | Clock output (open-drain)   |
| 13         | VDD    | Supply voltage; positive or negative steps in VDD can affect oscillator performance; recommend 100nF decoupling close to the device (see Fig. 30) |
| 14         | RESET/ | Output signal indicating RTC is operating in backup power mode  |
| 15         | EN     | Charge pump enable; activates VCHG 4.1V (typ.) charging source  |
| 16         | OSCI   | Oscillator input; high-impedance node; minimize wire length between quartz and package  |

**Package Dimensions**

5mm x 5mm x 1.4mm

**Pad Pitch**

0.8mm

**Pad Dimensions**

0.4mm x 0.3mm

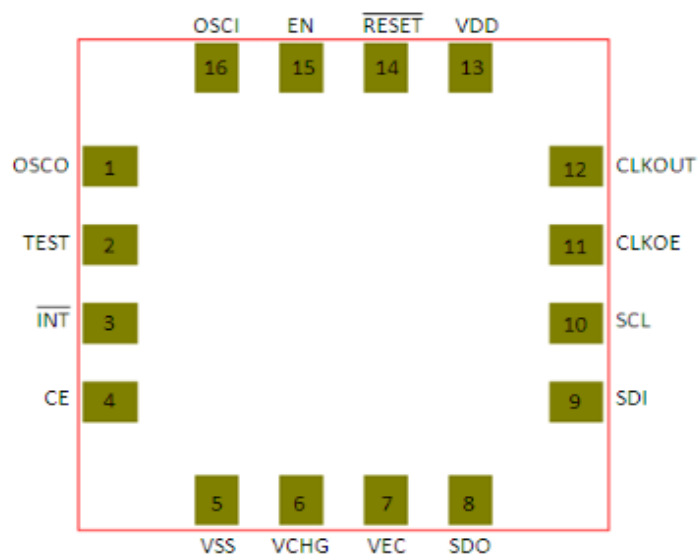

Figure 4: CBC34123 EnerChip™ RTC Package Pin-Out (top view, looking through package)

**Absolute Maximum Ratings**

| PARAMETER                    | CONDITION | MIN       | TYPICAL | MAX      | UNITS |
|------------------------------|-----------|-----------|---------|----------|-------|
| VDD with respect to GND      | 25 °C     | GND - 0.3 | -       | 6.0      | V     |
| ENABLE Input Voltage         | 25 °C     | GND - 0.3 | -       | VDD+0.3  | V     |
| VBAT <sup>(1)</sup>          | 25 °C     | 3.0       | -       | 4.15     | V     |
| VCHG <sup>(1)</sup>          | 25 °C     | 3.0       | -       | 4.15     | V     |
| RESET Output Voltage         | 25 °C     | GND - 0.3 | -       | VOUT+0.3 | V     |
| CP, Flying Capacitor Voltage | 25 °C     | GND - 0.3 | -       | 6.0      | V     |
| CN                           | 25 °C     | GND - 0.3 | -       | VDD+0.3  | V     |

(1) No external connections to these pins are allowed, except parallel EnerChips™.

**Integrated EnerChip™ Thin Film Battery Operating Characteristics**

| PARAMETER  | CONDITION              | MIN                    | TYPICAL            | MAX                 | UNITS      |        |
|--|------------------------|------------------------|--------------------|---------------------|------------|--------|
| Self-Discharge (5 yr. average)                               | Non-recoverable        | -                      | 2.5                | -                   | % per year |        |
|  | Recoverable            | -                      | 1.5 <sup>(1)</sup> | -                   | % per year |        |
| Operating Temperature  | -                      | -20                    | 25                 | +70                 | °C         |        |
| Storage Temperature  | -                      | -40                    | -                  | +125 <sup>(2)</sup> | °C         |        |
| Recharge Cycles<br>(to 80% of rated capacity)                | 25 °C                  | 10% depth-of-discharge | 5000               | -                   | -          | cycles |
|  |                        | 50% depth-of discharge | 1000               | -                   | -          | cycles |
|  | 40 °C                  | 10% depth-of-discharge | 2500               | -                   | -          | cycles |
|  |                        | 50% depth-of-discharge | 500                | -                   | -          | cycles |
| Recharge Time (to 80% of rated capacity; 4.1V charge; 25 °C) | Charge cycle 2         | -                      | 11                 | 22                  | minutes    |        |
|  | Charge cycle 1000      | -                      | 45                 | 70                  |            |        |
| Capacity   | 150nA discharge; 25 °C | 5                      | -                  | -                   | μAh        |        |

(1) First month recoverable self-discharge is 5% average.

(2) Storage temperature is for uncharged EnerChip™ CC device.

**Note:** All specification contained within this document are subject to change without notice.

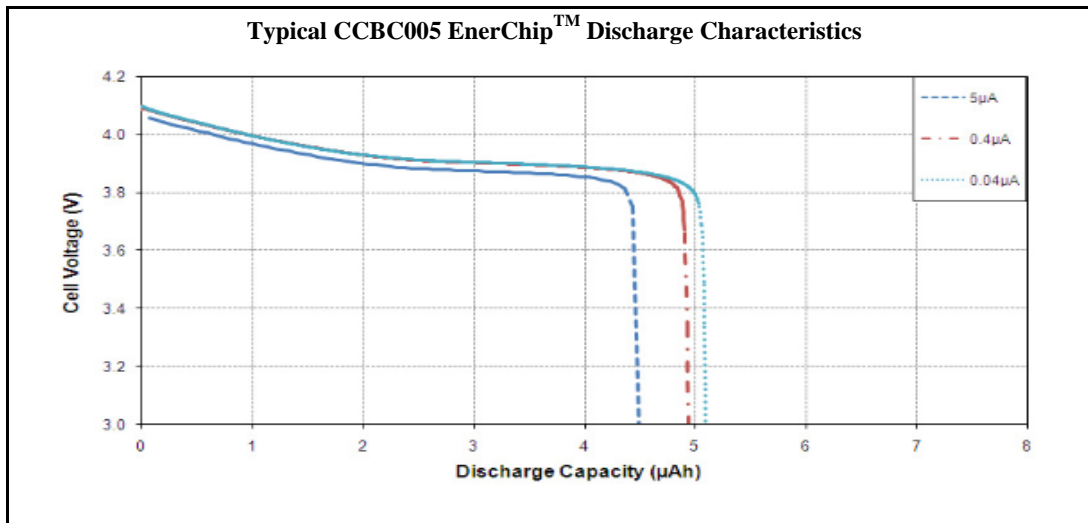

### Functional Description of Integrated PCF2123 Real-Time Clock

The PCF2123 contains 16 8-bit registers with an auto-incrementing address counter, an on-chip 32.768 kHz oscillator with two integrated load capacitors, a frequency divider which provides the source clock for the Real Time Clock (RTC), a programmable clock output, and a 6.25 Mbit/s SPI-bus. An offset register allows fine tuning of the clock.

All 16 registers are designed as addressable 8-bit parallel registers although not all bits are implemented.

- The first two registers (memory address 00h and 01h) are used as control registers.
- The memory addresses 02h through 08h are used as counters for the clock function (seconds up to years). The registers Seconds, Minutes, Hours, Days, Weekdays, Months, and Years are all coded in Binary Coded Decimal (BCD) format. When one of the RTC registers is written or read the contents of all counters are frozen. Therefore, faulty writing or reading of the clock and calendar during a carry condition is prevented.
- Addresses 09h through 0Ch define the alarm condition.
- Address 0Dh defines the offset calibration.
- Address 0Eh defines the clock out and timer mode.
- Address registers 0Eh and 0Fh are used for the countdown timer function. The countdown timer has four selectable source clocks allowing for countdown periods in the range from 244 ms up to four hours. There are also two pre-defined timers which can be used to generate an interrupt once per second or once per minute. These are defined in register Control\_2 (01h).

### Low Power Operation

Minimum power operation will be achieved by reducing the number and frequency of switching signals inside the IC, i.e., low frequency timer clocks and a low frequency CLKOUT will result in lower operating power. A second prime consideration is the series resistance  $R_s$  of the quartz used.

### Power Consumption with Respect to Quartz Series Resistance

The series resistance acts as a loss element. Low  $R_s$  will reduce current consumption further.

## PCF2123 Register Overview

16 registers are available. The time registers are encoded in the Binary Coded Decimal (BCD) format to simplify application use. Other registers are either bit-wise or standard binary.

Bit positions labeled as '-' are not implemented and will return a '0' when read. The bit position labeled as '--' is not implemented and will return a '0' or '1' when read. Bit positions labeled with N should always be written with logic '0' <sup>(1)</sup>.

| Address                             | Register name   | Bit                  |                        |                     |  |    |                        |          |     |
|-------------------------------------|-----------------|----------------------|------------------------|---------------------|--|----|------------------------|----------|-----|
|                                     |                 | 7                    | 6                      | 5                   | 4  | 3  | 2                      | 1        | 0   |
| <b>Control and status registers</b> |                 |                      |                        |                     |  |    |                        |          |     |
| 00h                                 | Control_1       | EXT_TEST             | N                      | STOP                | SR   | N  | 12_24                  | CIE      | N   |
| 01h                                 | Control_2       | MI                   | SI                     | MSF                 | TI_TP  | AF | TF                     | AIE      | TIE |
| <b>Time and date registers</b>      |                 |                      |                        |                     |  |    |                        |          |     |
| 02h                                 | Seconds         | OS                   | SECONDS (0 to 59)      |                     |  |    |                        |          |     |
| 03h                                 | Minutes         | --                   | MINUTES (0 to 59)      |                     |  |    |                        |          |     |
| 04h                                 | Hours           | -                    | -                      | AMPM                | HOURS (1 to 12) in 12 h mode<br>HOURS (0 to 23) in 24 h mode           |    |                        |          |     |
| 05h                                 | Days            | -                    | -                      | DAYS (1 to 31)      |  |    |                        |          |     |
| 06h                                 | Weekdays        | -                    | -                      | -                   | -  | -  | WEEKDAYS (0 to 6)      |          |     |
| 07h                                 | Months          | -                    | -                      | -                   | MONTHS (1 to 12)   |    |                        |          |     |
| 08h                                 | Years           | YEARS (0 to 99)      |                        |                     |  |    |                        |          |     |
| <b>Alarm registers</b>              |                 |                      |                        |                     |  |    |                        |          |     |
| 09h                                 | Minute_alarm    | AE_M                 | MINUTE_ALARM (0 to 59) |                     |  |    |                        |          |     |
| 0Ah                                 | Hour_alarm      | AE_H                 | -                      | AMPM                | HOUR_ALARM (1 to 12) in 12 h mode<br>HOUR_ALARM (0 to 23) in 24 h mode |    |                        |          |     |
| 0Bh                                 | Day_alarm       | AE_D                 | -                      | DAY_ALARM (1 to 31) |  |    |                        |          |     |
| 0Ch                                 | Weekday_alarm   | AE_W                 | -                      | -                   | -  | -  | WEEKDAY_ALARM (0 to 6) |          |     |
| <b>Offset register</b>              |                 |                      |                        |                     |  |    |                        |          |     |
| 0Dh                                 | Offset_register | MODE                 | OFFSET[6:0]            |                     |  |    |                        |          |     |
| <b>Timer registers</b>              |                 |                      |                        |                     |  |    |                        |          |     |
| 0Eh                                 | Timer_clkout    | -                    | COF[2:0]               |                     |  | TE | -                      | CTD[1:0] |     |
| 0Fh                                 | Countdown_timer | COUNTDOWN_TIMER[7:0] |                        |                     |  |    |                        |          |     |

**Power Supply Current Characteristics**
**T<sub>a</sub> = -20°C to +70°C**

| CHARACTERISTIC   | SYMBOL               | CONDITION   | MIN                   | MAX | UNITS |    |
|--|----------------------|---|-----------------------|-----|-------|----|
| Quiescent Current  | I <sub>Q</sub>       | ENABLE=GND  | V <sub>DD</sub> =3.3V | -   | 3.5   | μA |
|  |                      |   | V <sub>DD</sub> =5.5V | -   | 6.0   | μA |
|  |                      | ENABLE=V <sub>DD</sub>  | V <sub>DD</sub> =3.3V | -   | 35    | μA |
|  |                      |   | V <sub>DD</sub> =5.5V | -   | 38    | μA |
| EnerChip Cutoff Current<br>(I <sub>QBATON</sub> adds to RTC<br>current when in backup<br>mode) | I <sub>QBATOFF</sub> | V <sub>BAT</sub> < V <sub>BATCO</sub> ,<br>V <sub>OUT</sub> =0                          | -                     | 0.5 | nA    |    |
|  | I <sub>QBATON</sub>  | V <sub>BAT</sub> > V <sub>BATCO</sub> ,<br>ENABLE=V <sub>DD</sub> , I <sub>OUT</sub> =0 | -                     | 42  | nA    |    |

**Interface Logic Signal Characteristics**
**V<sub>DD</sub> = 2.5V to 5.5V, T<sub>a</sub> = -20°C to +70°C**

| CHARACTERISTIC              | SYMBOL          | CONDITION   | MIN                                       | MAX  | UNITS |
|-----------------------------|-----------------|---|---|------|-------|
| High Level Input Voltage    | V <sub>IH</sub> | -   | V <sub>DD</sub> - 0.5                     | -    | Volts |
| Low Level Input Voltage     | V <sub>IL</sub> | -   | -   | 0.5  | Volts |
| High Level Output Voltage   | V <sub>OH</sub> | V <sub>DD</sub> > V <sub>TH</sub> (see Figures 4<br>and 5) I <sub>L</sub> =10μA | V <sub>DD</sub> -<br>0.04V <sup>(1)</sup> | -    | Volts |
| Low Level Output Voltage    | V <sub>OL</sub> | I <sub>L</sub> = -100μA   | -   | 0.3  | Volts |
| Logic Input Leakage Current | I <sub>IN</sub> | 0 < V <sub>IN</sub> < V <sub>DD</sub>   | -1.0                                      | +1.0 | nA    |

<sup>(1)</sup> RESET tracks V<sub>DD</sub>; RESET = V<sub>DD</sub> - (I<sub>OUT</sub> × R<sub>OUT</sub>).

**RESET Signal AC/DC Characteristics**
**V<sub>DD</sub> = 2.5V to 5.5V, T<sub>a</sub> = -20°C to +70°C**

| CHARACTERISTIC  | SYMBOL              | CONDITION  | MIN  | MAX  | UNITS |
|---|---------------------|--|------|------|-------|
| V <sub>DD</sub> Rising to $\overline{\text{RESET}}$<br>Rising   | t <sub>RESETH</sub> | V <sub>DD</sub> rising from 2.8V to 3.1V<br>in <10μs   | 60   | 200  | ms    |
| V <sub>DD</sub> Falling to $\overline{\text{RESET}}$<br>Falling   | t <sub>RESETL</sub> | V <sub>DD</sub> falling from 3.1V to 2.8V<br>in <100ns | 0.5  | 2    | μs    |
| TRIP Voltage<br>V <sub>DD</sub> Rising  | V <sub>RESET</sub>  | V <sub>MODE</sub> =GND                                 | 2.85 | 3.15 | V     |
| $\overline{\text{RESET}}$ Hysteresis<br>Voltage <sup>(3)</sup><br>(V <sub>DD</sub> to $\overline{\text{RESET}}$ ) | V <sub>HYST</sub>   | V <sub>MODE</sub> =V <sub>DD</sub>                     | 60   | 100  | mV    |
|   |                     | V <sub>MODE</sub> =GND                                 | 45   | 75   |       |
|   |                     | V <sub>MODE</sub> = V <sub>DD</sub> /2                 | 30   | 50   |       |

<sup>(2)</sup> Users- selectable trip voltage can be set by placing a resistor divider from the V<sub>MODE</sub> pin to GND. Refer to Figure 8.

<sup>(3)</sup> The Hysteresis is a function of trip level in Mode 2. Refer to Figure 9.

**Charge Pump Characteristics**
**V<sub>DD</sub> = 2.5V to 5.5V, Ta = -20°C to +70°C**

| CHARACTERISTIC                               | SYMBOL              | CONDITION  | MIN   | MAX   | UNITS              |
|--|---------------------|--|-------|-------|--------------------|
| ENABLE=V <sub>DD</sub> to Charge Pump Active | t <sub>CPON</sub>   | ENABLE to 3rd charge pump pulse, V <sub>DD</sub> =3.3V   | 60    | 80    | μs                 |
| ENABLE Falling to Charge Pump Inactive       | t <sub>CPOFF</sub>  | -  | 0     | 1     | μs                 |
| Charge Pump Frequency                        | f <sub>CP</sub>     | -  | -     | 120   | KHz <sup>(1)</sup> |
| Charge Pump Resistance                       | R <sub>CP</sub>     | Delta V <sub>BAT</sub> , for I <sub>BAT</sub> charging current of 1μA to 100μA<br>C <sub>FLY</sub> =0.1μF, C <sub>BAT</sub> =1.0μF | 150   | 300   | Ω                  |
| V <sub>CHG</sub> Output Voltage              | V <sub>CP</sub>     | C <sub>FLY</sub> =0.1μF, C <sub>BAT</sub> =1.0μF, I <sub>OUT</sub> =1μA, Temp=+25°C  | 4.075 | 4.125 | V                  |
| V <sub>CHG</sub> Temp. Coefficient           | T <sub>CCP</sub>    | I <sub>OUT</sub> =1μA, Temp=+25°C  | -2.0  | -2.4  | mV/°C              |
| Charge Pump Current Drive                    | I <sub>CP</sub>     | I <sub>BAT</sub> =1mA<br>C <sub>FLY</sub> =0.1μF, C <sub>BAT</sub> =1.0μF  | 1.0   | -     | mA                 |
| Charge Pump on Voltage                       | V <sub>ENABLE</sub> | ENABLE=V <sub>DD</sub>   | 2.5   | -     | V                  |

*(1) f<sub>cp</sub> = 1/t<sub>CPPER</sub>*
**Additional Characteristics**
**Ta = -20°C to +70°C**

| CHARACTERISTIC                     | SYMBOL             | CONDITION  | LIMITS |      | UNITS |
|------------------------------------|--------------------|--|--------|------|-------|
|                                    |                    |  | MIN    | MAX  |       |
| V <sub>BAT</sub> Cutoff Threshold  | V <sub>BATCO</sub> | I <sub>OUT</sub> =1μA  | 2.75   | 3.25 | V     |
| Cutoff Temp. Coefficient           | T <sub>CCO</sub>   | -  | +1     | +2   | mV/°C |
| V <sub>BAT</sub> Cutoff Delay Time | t <sub>COOFF</sub> | V <sub>BAT</sub> from 40mV above to 20mV below V <sub>BATCO</sub><br>I <sub>OUT</sub> =1μA | 40     | -    | ms    |

**Note: All specification contained within this document are subject to change without notice.**
**Disclaimer of Warranties; As Is**

The information provided in this data sheet is provided "As Is" and Cardinal Components Inc. disclaims all representations or warranties of any kind, express or implied, relating to this data sheet and the Cardinal Components Inc. EnerChip™ product described herein, including without limitation, the implied warranties of merchantability, fitness for a particular purpose, non-infringement, title, or any warranties arising out of course of dealing, course of performance, or usage of trade. Cardinal Components Inc. EnerChip™ products are not approved for use in life critical applications. Users shall confirm suitability of the Cardinal Components Inc. EnerChip™ product in any products or applications in which the Cardinal Components Inc. EnerChip™ product is adopted for use and are solely responsible for all legal, regulatory, and safety-related requirements concerning their products and applications and any use of the Cardinal Components Inc. EnerChip™ product described herein in any such product or applications. EnerChip™ is a Trademark of Cymbet Corporation.

