

# 256Mbit GDDR3 SDRAM

**Revision 1.3**

**May 2007**

## **Notice**

**INFORMATION IN THIS DOCUMENT IS PROVIDED IN RELATION TO SAMSUNG PRODUCTS, AND IS SUBJECT TO CHANGE WITHOUT NOTICE.**

**NOTHING IN THIS DOCUMENT SHALL BE CONSTRUED AS GRANTING ANY LICENSE, EXPRESS OR IMPLIED, BY ESTOPPEL OR OTHERWISE,**

**TO ANY INTELLECTUAL PROPERTY RIGHTS IN SAMSUNG PRODUCTS OR TECHNOLOGY. ALL INFORMATION IN THIS DOCUMENT IS PROVIDED**

**ON AS "AS IS" BASIS WITHOUT GUARANTEE OR WARRANTY OF ANY KIND.**

1. For updates or additional information about Samsung products, contact your nearest Samsung office.
2. Samsung products are not intended for use in life support, critical care, medical, safety equipment, or similar applications where Product failure could result in loss of life or personal or physical harm, or any military or defense application, or any governmental procurement to which special terms or provisions may apply.

**\* Samsung Electronics reserves the right to change products or specification without notice.**

**Revision History**

Revision	Month	Year	History
0.0	March	2006	- <b>Target Spec</b>
0.1	November	2006	- Changed speed bin organization
1.0	January	2007	- <b>Final Spec</b> - Added current data and IBIS data
1.1	February	2007	- Added Power dissipation data on page 48. - Added comment on page 23. - Corrected typo
1.2	March	2007	- Corrected typo on page 53.
1.3	May	2007	- Added revision ID on page 16.

## 2M x 32Bit x 4 Banks Graphic Double Data Rate 3 Synchronous DRAM with Uni-directional Data Strobe

### 1.0 FEATURES

- 1.8V  $\pm$  0.1V power supply for device operation for -BC\*\*
- 1.8V  $\pm$  0.1V power supply for I/O interface for -BC\*\*
- 1.9V  $\pm$  0.1V power supply for device operation for -BJ\*\*
- 1.9V  $\pm$  0.1V power supply for I/O interface for -BJ\*\*
- On-Die Termination (ODT)
- Output Driver Strength adjustment by EMRS
- Calibrated output drive
- 1.8V Pseudo Open drain compatible inputs/outputs
- 4 internal banks for concurrent operation
- Differential clock inputs (CK and  $\overline{\text{CK}}$ )
- Commands entered on each positive CK edge
- CAS latency : 7, 8, 9, 10, 11, 12 (clock)
- Programmable Burst length : 4 and 8
- Programmable Write latency : 1, 2, 3, 4, 5, 6 and 7 (clock)
- Single ended READ strobe (RDQS) per byte
- Single ended WRITE strobe (WDQS) per byte
- RDQS edge-aligned with data for READs
- WDQS center-aligned with data for WRITEs
- Data Mask(DM) for masking WRITE data
- Auto & Self refresh modes
- Auto Precharge option
- 32ms, auto refresh (4K cycle)
- 136 Ball FBGA
- Maximum clock frequency up to 1000MHz
- Maximum data rate up to 2.0Gbps/pin
- DLL for outputs
- Boundary scan function with SEN pin
- Mirror function with MF pin

### 2.0 ORDERING INFORMATION

Part NO.	Max Freq.	Max Data Rate	VDD&VDDQ	Package
K4J55323QI-BJ1A	1000MHz	2.0Gbps/pin	1.9V $\pm$ 0.1V	136 Ball FBGA
K4J55323QI-BJ11	900MHz	1.8Gbps/pin		
K4J55323QI-BC12	800MHz	1.6Gbps/pin	1.8V $\pm$ 0.1V	
K4J55323QI-BC14	700MHz	1.4Gbps/pin		

### 3.0 GENERAL DESCRIPTION

#### FOR 2M x 32Bit x 4 Bank GDDR3 SDRAM

The K4J55323QI is 268,435,456 bits of hyper synchronous data rate Dynamic RAM organized as 4 x 2,097,152 words by 32 bits, fabricated with SAMSUNG's high performance CMOS technology. Synchronous features with Data Strobe allow extremely high performance up to 8.0GB/s/chip. I/O transactions are possible on both edges of the clock cycle. Range of operating frequencies, and programmable latencies allow the device to be useful for a variety of high performance memory system applications.

4.0 PIN CONFIGURATION

Normal Package (Top View)

	1	2	3	4	5	6	7	8	9	10	11	12
A	VDDQ	VDD	VSS	ZQ					MF	VSS	VDD	VDDQ
B	VSSQ	DQ0	DQ1	VSSQ					VSSQ	DQ9	DQ8	VSSQ
C	VDDQ	DQ2	DQ3	VDDQ					VDDQ	DQ11	DQ10	VDDQ
D	VSSQ	WDQS0	RDQS0	VSSQ					VSSQ	RDQS1	WDQS1	VSSQ
E	VDDQ	DQ4	DM0	VDDQ					VDDQ	DM1	DQ12	VDDQ
F	VDD	DQ6	DQ5	$\overline{\text{CAS}}$					$\overline{\text{CS}}$	DQ13	DQ14	VDD
G	VSS	VSSQ	DQ7	BA0					BA1	DQ15	VSSQ	VSS
H	VREF	A1	$\overline{\text{RAS}}$	CKE					$\overline{\text{WE}}$	RFM	A5	VREF
J	VSSA	RFU1	RFU2	VDDQ					VDDQ	$\overline{\text{CK}}$	CK	VSSA
K	VDDA	A10	A2	A0					A4	A6	A8/AP	VDDA
L	VSS	VSSQ	DQ25	A11					A7	DQ17	VSSQ	VSS
M	VDD	DQ24	DQ27	A3					A9	DQ19	DQ16	VDD
N	VDDQ	DQ26	DM3	VDDQ					VDDQ	DM2	DQ18	VDDQ
P	VSSQ	WDQS3	RDQS3	VSSQ					VSSQ	RDQS2	WDQS2	VSSQ
R	VDDQ	DQ28	DQ29	VDDQ					VDDQ	DQ21	DQ20	VDDQ
T	VSSQ	DQ30	DQ31	VSSQ					VSSQ	DQ23	DQ22	VSSQ
V	VDDQ	VDD	VSS	SEN					RESET	VSS	VDD	VDDQ

Note :

1. RFU1 is reserved for future use
2. RFU2 is reserved for future use
3. RFM : When the MF ball is tied LOW, RFM(H10) receiver is disabled and it recommended to be driven to a static LOW state, however, either static HIGH or floating state on this pin will not cause any problem for the DRAM. When the MF ball is tied HIGH, RAS(H3) becomes RFM due to mirror function and the receiver is disabled. It recommended to be driven to a static LOW state, however, either static HIGH or floating state on this pin will not cause any problem for the DRAM

Please refer to Mirror Function Signal Mapping table at page 22.

## 5.0 INPUT/OUTPUT FUNCTIONAL DESCRIPTION

Symbol	Type	Function
CK, $\overline{CK}$	Input	<b>Clock:</b> CK and $\overline{CK}$ are differential clock inputs. CMD, ADD inputs are sampled on the crossing of the positive edge of CK and negative edge of $\overline{CK}$ . Output (read) data is referenced to the crossings of CK and $\overline{CK}$ (both directions of crossing). CK, $\overline{CK}$ should be maintained stable, except self-refresh mode
CKE	Input	<b>Clock Enable:</b> CKE HIGH activates, and CKE Low deactivates, internal clock signals and device input buffers and output drivers. Taking CKE Low provides Precharge Power-Down and Self Refresh operation (all banks idle), or Active Power-Down (row Active in any bank). CKE is synchronous for power down entry and exit, and for self refresh entry. CKE is asynchronous for self refresh exit. CKE must be maintained high throughout read and write accesses. Input buffers, excluding CK, $\overline{CK}$ and CKE are disabled during power-down. Input buffers, excluding CKE, are disabled during self refresh.
CS	Input	<b>Chip Select:</b> All commands are masked when $\overline{CS}$ is registered HIGH. $\overline{CS}$ provides for external bank selection on systems with multiple banks. $\overline{CS}$ is considered part of the command code.
$\overline{RAS}$ , $\overline{CAS}$ , $\overline{WE}$	Input	<b>Command Inputs:</b> $\overline{RAS}$ , $\overline{CAS}$ and $\overline{WE}$ (along with $\overline{CS}$ ) define the command being entered.
DM0 ~DM3	Input	<b>Input Data Mask:</b> DM is an input mask signal for write data. Input data is masked when DM is sampled HIGH coincident with that input data during a Write access. DM is sampled on both edges of clock. Although DM pins are input only, the DM loading matches the DQ and WDQS loading.
BA0,BA1	Input	<b>Bank Address Inputs:</b> BA0 and BA1 define to which bank an Active, Read, Write or Precharge command is being applied.
A0 ~ A11	Input	<b>Address Inputs:</b> Provided the row address for Active commands and the column address and Auto Precharge bit for Read/Write commands to select one location out of the memory array in the respective bank. A8 is sampled during a Precharge command to determine whether the Precharge applies to one bank (A8 LOW) or all banks (A8 HIGH). If only one bank is to be precharged, the bank is selected by BA0, BA1,BA2. The address inputs also provide the op-code during Mode Register Set commands. Row addresses : RA0 ~ RA11, Column addresses : CA0 ~ CA7, CA9 . Column address CA8 is used for auto precharge.
DQ0 ~ DQ31	Input/ Output	<b>Data Input/ Output:</b> Bi-directional data bus.
RDQS0 ~ RDQS3	Output	<b>READ Data Strobe:</b> Output with read data. RDQS is edge-aligned with read data.
WDQS0 ~ WDQS3	Input	<b>WRITE Data Strobe:</b> Input with write data. WDQS is center-aligned to the inout data.
NC/RFU		<b>No Connect:</b> No internal electrical connection is present.
V <sub>DDQ</sub>	Supply	DQ Power Supply
V <sub>SSQ</sub>	Supply	DQ Ground
V <sub>DD</sub>	Supply	Power Supply
V <sub>SS</sub>	Supply	Ground
V <sub>DDA</sub>	Supply	DLL Power Supply
V <sub>SSA</sub>	Supply	DLL Ground
V <sub>REF</sub>	Supply	<b>Reference voltage:</b> 0.7*VDDQ , <b>2 Pins :</b> (H12) for Data input , (H1) for CMD and ADDRESS
MF	Input	Mirror Function for clamshell mounting of DRAMs. VDDQ CMOS input.
ZQ	Reference	Resistor connection pin for On-die termination.
RES	Input	Reset pin: RESET pin is a VDDQ CMOS input
SEN	Input	<b>Scan enable :</b> Must tie to the ground in case not in use. VDDQ CMOS input.
RFM	Input	<b>Reserved for Mirror Function :</b> When the MF ball is tied low, RFM(H10) is recommended to be driven to logic low state. When the MF ball is tied high, RAS(H3) switch to RFM and is recommended to be driven to logic low state

6.0 BLOCK DIAGRAM (2Mbit x 32I/O x 4 Bank)

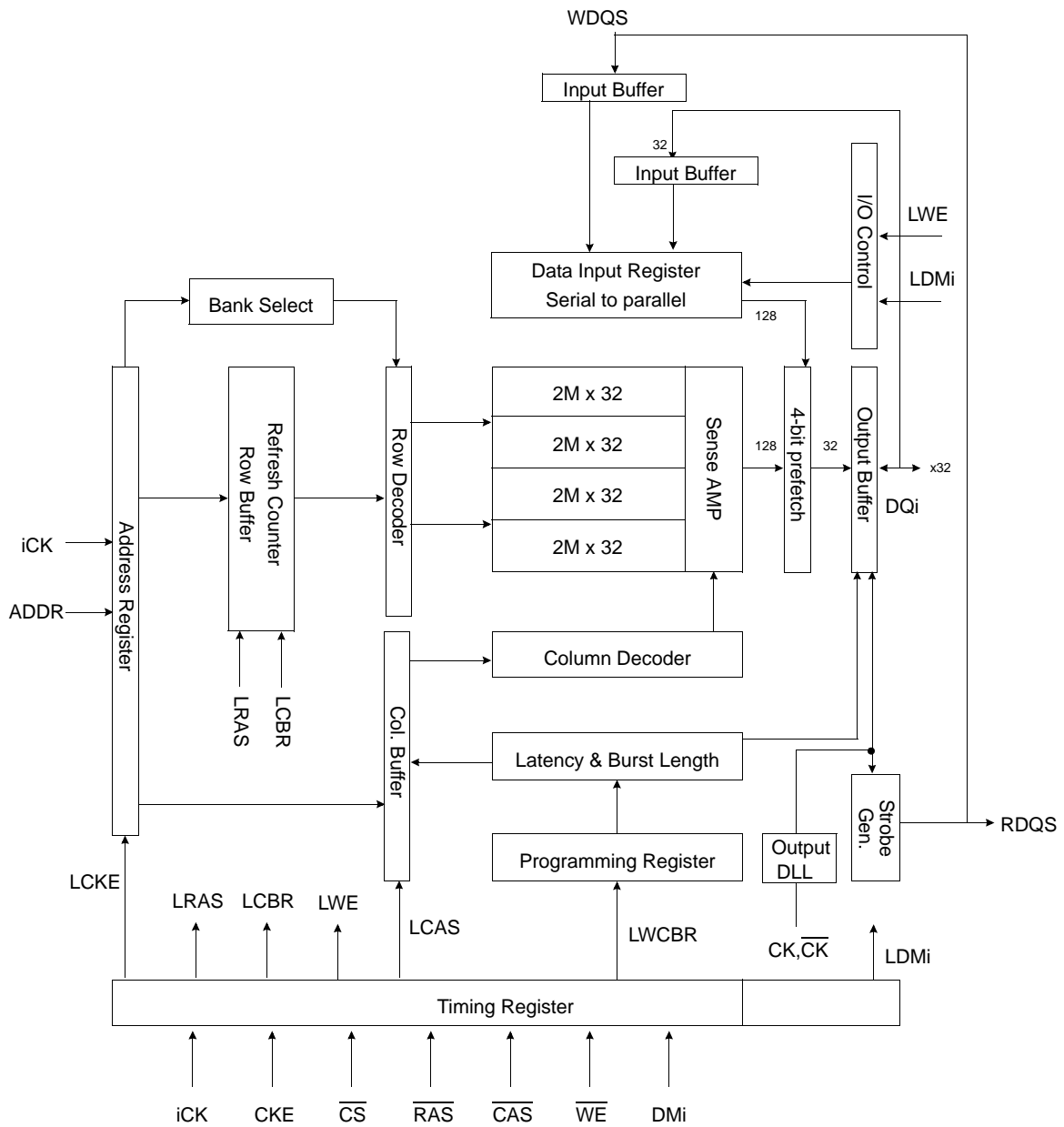

\* iCK : internal clock

7.0 FUNCTIONAL DESCRIPTION

7.1 Simplified State Diagram

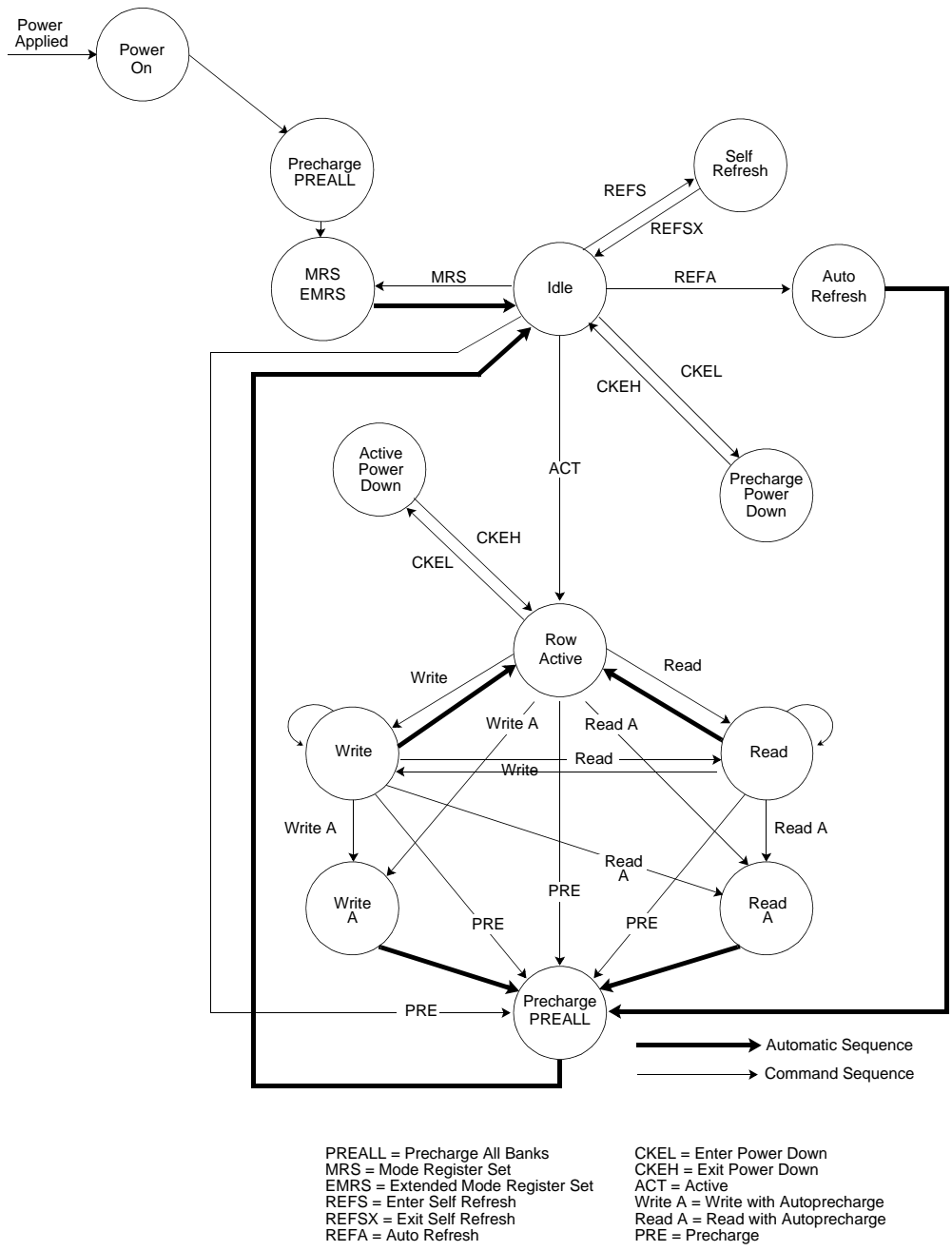

7.2 INITIALIZATION

GDDR3 SDRAMs must be powered up and initialized in a predefined manner. Operational procedures other than those specified may result in undefined operation.

1. Apply power and keep CKE/RESET at low state ( All other inputs may be undefined)
  - Apply VDD and VDDQ simultaneously
  - Apply VDDQ before Vref. ( Inputs are not recognized as valid until after  $V_{REF}$  is applied )
  - The VDD voltage ramp time must be no greater than 200 ms from when VDD ramps from 300 mV to VDD min and the power voltage ramps are without any slope reversal
2. Required minimum 100us for the stable power before RESET pin transition to HIGH
  - Upon power-up the address/command active termination value will automatically be set based off the state of RESET and CKE.
  - On the rising edge of RESET the CKE pin is latched to determine the address and command bus termination value.
    - If CKE is sampled at a zero the address termination is set to 1/2 of ZQ.
    - If CKE is sampled at a one the address termination is set to ZQ.
  - RESET must be maintained at a logic LOW level and CS at a logic high value during power-up to ensure that the DQ outputs will be in a High-Z state, all active terminators off, and all DLLs off.
3. Minimum 200us delay required prior to applying any executable command after stable power and clock.
4. Once the 200us delay has been satisfied, a DESELECT or NOP command should be applied, then RESET and CKE should be brought to HIGH,
5. Issue a PRECHARGE ALL command following after NOP command.
6. Issue a EMRS command (BA1BA0="01") to enable the DLL.
7. Issue MRS command (BA0BA1 = "00") to reset the DLL and to program the operating parameters.
  - 20K clock cycles are required between the DLL to lock.
8. Issue a PRECHARGE ALL command
9. Issue at least two AUTO refresh command to update the driver impedance and calibrate the output drivers.

Following these requirements, the GDDR3 SDRAM is ready for normal operation.

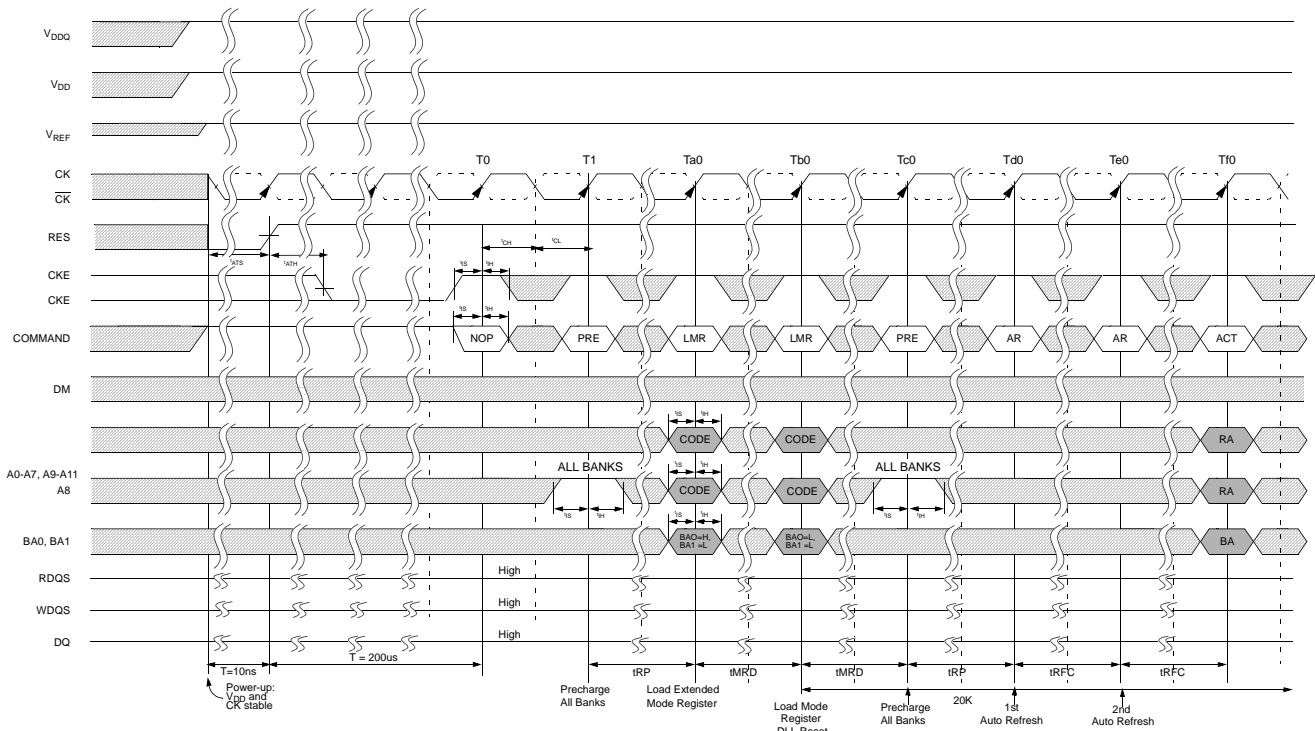

7.3 MODE REGISTER SET(MRS)

The mode register stores the data for controlling the various operating modes of GDDR3 SDRAM. It programs CAS latency, addressing mode, test mode and various vendor specific options to make GDDR3 SDRAM useful for variety of different applications. The default value of the mode register is not defined, therefore the mode register must be written after EMRS setting for the proper operation. The mode register is written by asserting low on  $\overline{CS}$ ,  $\overline{RAS}$ ,  $\overline{CAS}$  and  $\overline{WE}$  (The GDDR3 SDRAM should be in active mode with CKE already high prior to writing into the mode register). The state of address pins A0 ~ A11 and BA0, BA1 in the same cycle as  $\overline{CS}$ ,  $\overline{RAS}$ ,  $\overline{CAS}$  and  $\overline{WE}$  going low is written in the mode register. Minimum clock cycles specified as tMRD are required to complete the write operation in the mode register. The mode register contents can be changed using the same command and clock cycle requirements during operation as long as all banks are in the idle state. The mode register is divided into various fields depending on functionality. The Burst length uses A0 ~ A1. CAS latency (read latency from column address) uses A2, A6 ~ A4. A7 is used for test mode. A8 is used for DLL reset. A9 ~ A11 are used for Write latency. Refer to the table for specific codes for various addressing modes and CAS latencies.

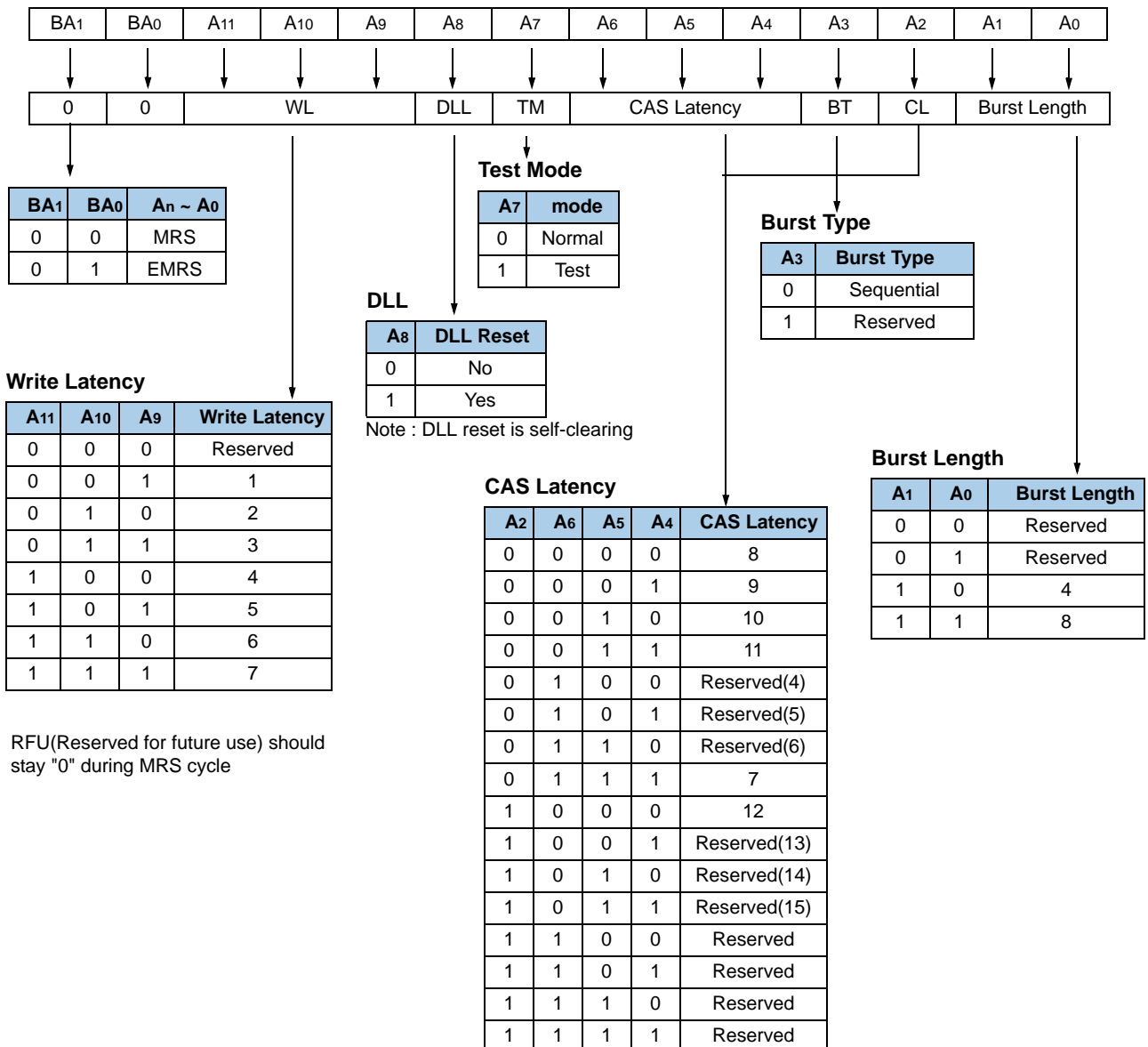

RFU(Reserved for future use) should stay "0" during MRS cycle

## PROGRAMMABLE IMPEDANCE OUTPUT BUFFER AND ACTIVE TERMINATOR

The GDDR3 SDRAM is equipped with programmable impedance output buffers and Active Terminators. This allows a user to match the driver impedance to the system. To adjust the impedance, an external precision resistor(RQ) is connected between the ZQ pin and Vss. The value of the resistor must be six times of the desired output impedance.

For example, a 240Ω resistor is required for an output impedance of 40 Ω. To ensure that output impedance is one sixth the value of RQ (within 10 %), the range of RQ is 120Ω to 360Ω (20Ω to 60Ω) output impedance.

MF,SEN, RES, CK and /CK are not internally terminated. CK and /CK will be terminated on the system module using external 1% resistors. The output impedance is updated during all AUTO REFRESH commands and NOP commands when a READ is not in progress to compensate for variations in voltage supply and temperature. The output impedance updates are transparent to the system. Impedance updates do not affect device operation, and all data sheet timing and current specifications are met during update. To guarantee optimum output driver impedance after power-up, the GDDR3(x32) needs at least 20us after the clock is applied and stable to calibrate the impedance upon power-up. The user may operate the part with less than 20us, but the optimal output impedance is not guaranteed. The value of ZQ is also used to calibrate the internal address/command termination resistors. The two termination values that are selectable during power up are 1/2 of ZQ and ZQ. The value of ZQ is used to calibrate the internal DQ termination resistors. The two termination values that are selectable are 1/4 of ZQ and 1/2 of ZQ.

## BURST LENGTH

Read and write accesses to the GDDR3 SDRAM are burst oriented, with the burst length being programmable, as shown in MRS table. The burst length determines the maximum number of column locations that can be accessed for a given READ or WRITE command. Reserved states should not be used, as unknown operation or incompatibility with future versions may result. When a READ or WRITE command is issued, a block of columns equal to the burst length is effectively selected. All accesses for that burst take place within the block, meaning that the burst will wrap within the block if a boundary is reached. The block is uniquely selected by A2-Ai when the burst length is set to four (Where Ai is the most significant column address bit for a given configuration). The remaining (least significant) address bit(s) is (are) used to select the starting location within the block. The programmable burst length applies to both READ and WRITE bursts.

## BURST TYPE

Accesses within a given burst must be programmed to be sequential; this is referred to as the burst type and is selected via bit M3. This device does not support the interleaved burst mode found in GDDR SDRAM devices. The ordering of accesses within a burst is determined by the burst length, the burst type, and the starting column address, as shown in below table: Burst Definition

Burst Definition

Burst Length	Starting Column Address			Order of Accesses Within a Burst
				Type= Sequential
4	A2	A1	A0	
	0	0	0	0 - 1 - 2 - 3
8	A2	A1	A0	
	0	0	0	0 - 1 - 2 - 3 - 4 - 5 - 6 - 7
	1	0	0	4 - 5 - 6 - 7 - 0 - 1 - 2 - 3

Note : 1. For a burst length of four, A2-A7 select the block of four burst; A0-A1 select the starting column within the block and must be set to zero  
2. For a burst length of eight, A3-A7 select the block of eight burst; A0-A2 select the starting column within the block.

CAS LATENCY (READ LATENCY)

The CAS latency is the delay, in clock cycles, between the registration of a READ command and the availability of the first bit of output data. The latency can be set to 7~12 clocks. If a READ command is registered at clock edge  $n$ , and the latency is  $m$  clocks, the data will be available nominally coincident with clock edge  $n+m$ . Below table indicates the operating frequencies at which each CAS latency setting can be used. Reserved states should not be used as unknown operation or incompatibility with future versions may result.

CAS Latency

SPEED	Allowable operating frequency (MHz)					
	CL=12	CL=11	CL=10	CL=9	CL=8	CL=7
-BJ1A	≤ 1000		-	-	-	-
-BJ11		≤ 900				
-BC12		≤ 800				
-BC14			≤ 700	-	-	-

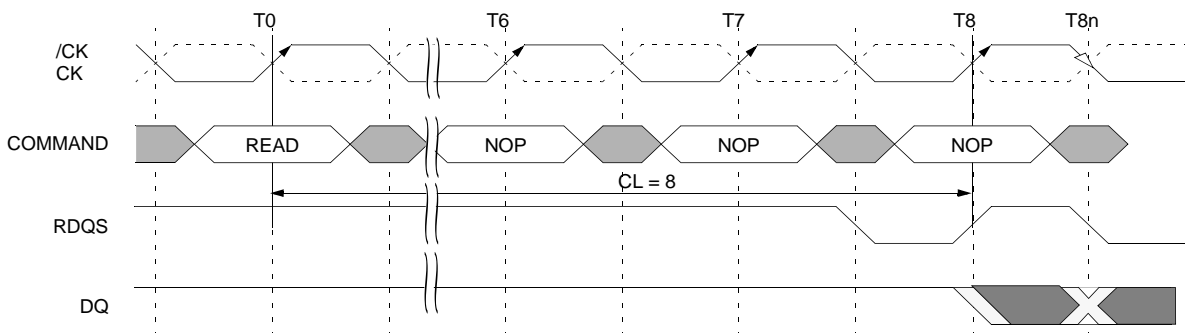
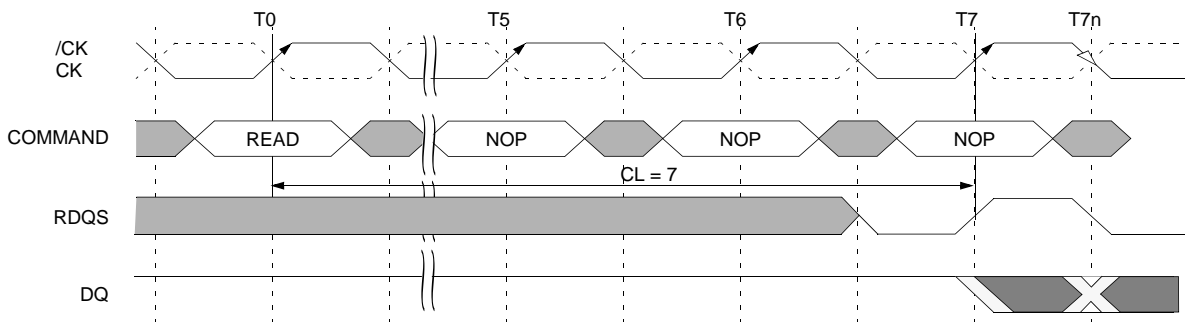

Burst Length = 4 in the cases shown  
Shown with nominal  $t_{AC}$  and nominal  $t_{DSDQ}$

■ DON'T CARE    □ TRANSITIONING DATA

WRITE LATENCY

The Write latency (WL) is the delay, in clock cycles, between the registration of a WRITE command and the availability of the first bit of input data. The latency can be set from 1 to 7 clocks depending in the operating frequency and desired current draw. When the write latencies are set to 1 or 2 or 3 clocks, the input receivers never turn off when the WRITE command is registered. If a WRITE command is registered at clock edge  $n$ , and the latency is  $m$  clocks, the data will be available nominally coincident with clock edge  $n+m$ . Reserved states should not be used as unknown operation or incompatibility with future versions may result.

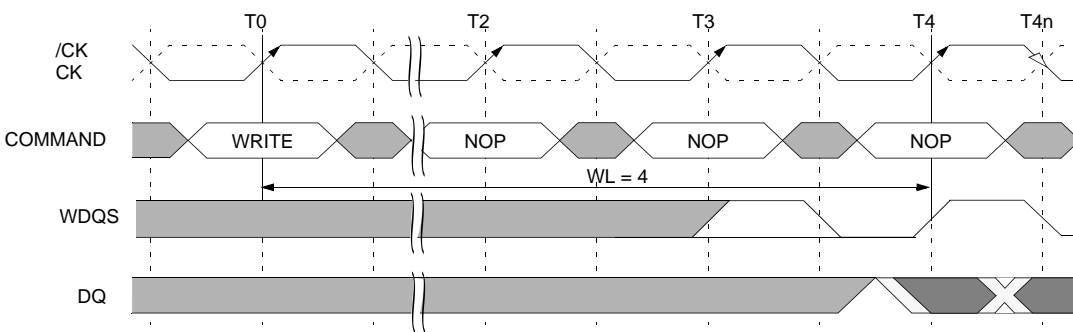
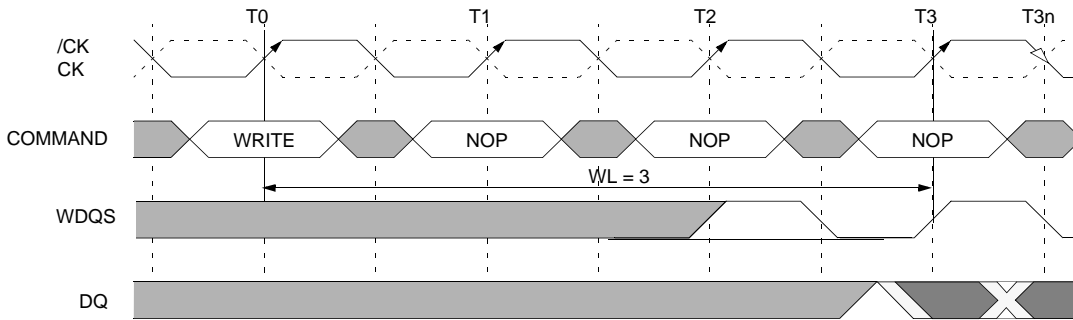

Burst Length = 4 in the cases shown

■ DON'T CARE    □ TRANSITIONING DATA

**TEST MODE**

The normal operating mode is selected by issuing a MODE REGISTER SET command with bits A7 set to zero, and bits A0-A6 and A8-A11 set to the desired values. Test mode is entered by issuing a MODE REGISTER SET command with bit A7 set to one, and bits A0-A6 and A8-A11 set to the desired values. Test mode functions are specific to each Dram Manufacturer and its exact functions are hidden from the user.

**DLL RESET**

The normal operating mode is selected by issuing a MODE REGISTER SET command with bit A7 set to zero, and bits A0-A6 and A8-A11 set to the desired values. A DLL reset is initiated by issuing a MODE REGISTER SET command with bit A8 set to one, and bits A0-A7 and A9-A11 set to the desired values. When a DLL Reset is complete the GDDR3 SDRAM reset bit 8 of the mode register to a zero. After DLL Reset MRS, Power down can not be issued within 10 clock.

In case the clock frequency need to be changed after the power-up, 256Mb GDDR3 doesn't require DLL reset. Instead, DLL should be disabled first before the frequency changed and then change the clock frequency as needed. After the clock frequency changed, there needed some time till clock become stable and then enable the DLL and then 20K cycle required to lock the DLL

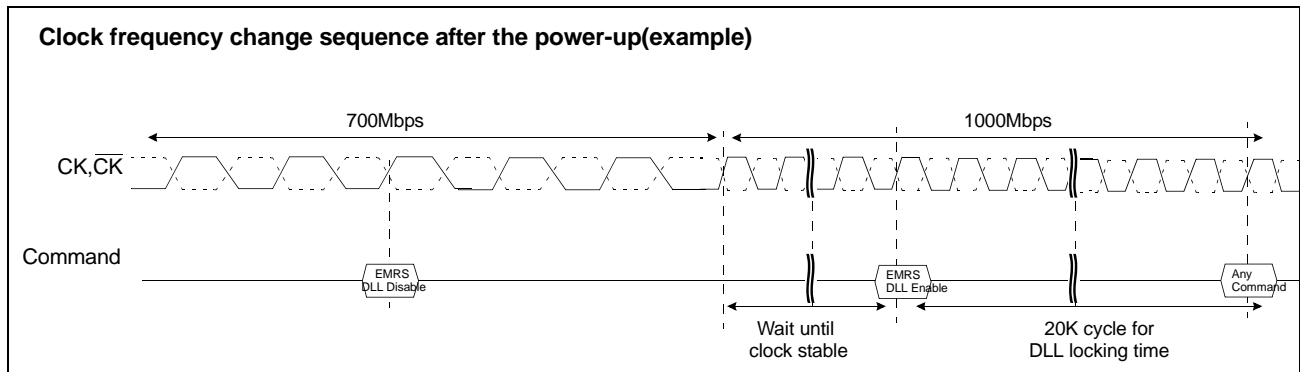

7.4 EXTENDED MODE REGISTER SET(EMRS)

The extended mode register stores the data output driver strength and on-die termination options. The extended mode register is written by asserting low on CS, RAS, CAS, WE and high on BA0(The GDDR3 SDRAM should be in all bank precharge with CKE already high prior to writing into the extended mode register). The state of address pins A0 ~ A11 and BA0,BA1 in the same cycle as CS, RAS, CAS and WE going low are written in the extended mode register. The minimum clock cycles specified as tMRD are required to complete the write operation in the extended mode register. 4 kinds of the output driver strength are supported by EMRS (A1, A0) code. The mode register contents can be changed using the same command and clock cycle requirements during operation as long as all banks are in the idle state. "High" on BA0 is used for EMRS. Refer to the table for specific codes.

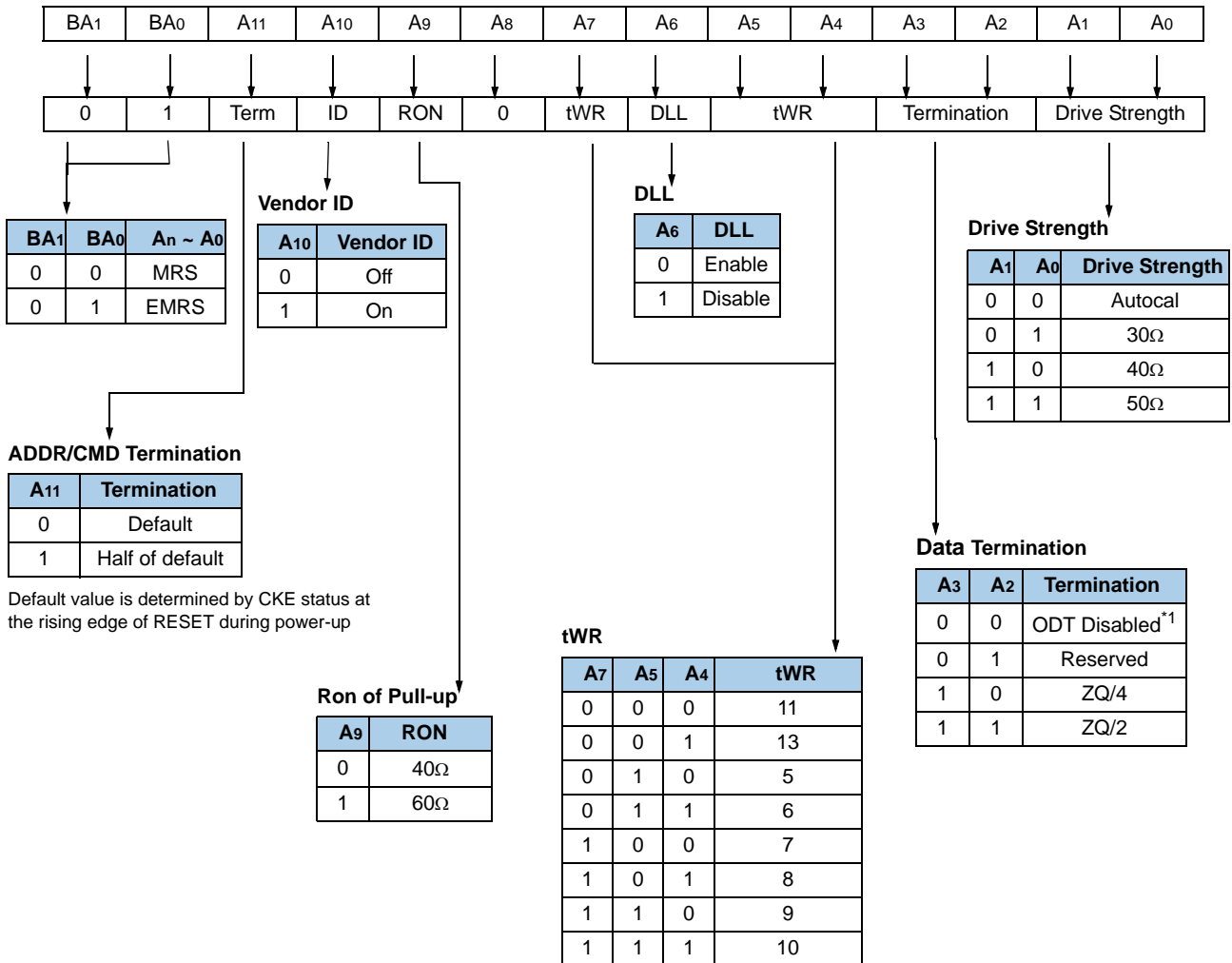

RFU(Reserved for future use) should stay "0" during EMRS cycle

\* ZQ : Resistor connection pin for On-die termination

\* 1 : ALL ODT will be disabled

**DLL ENABLE/DISABLE**

The DLL must be enabled for normal operation. DLL enable is required during power-up initialization and upon returning to normal operation after disabling the DLL for debugging or evaluation. (When the device exits self refresh mode, the DLL is enabled automatically.) Any time the DLL is enabled, 20K clock cycles must occur before an any command can be issued.

**DATA TERMINATION**

The Data Termination, DT, is used to determine the value of the internal data termination resistors. The GDDR3 SDRAM supports 60 $\Omega$  and 120 $\Omega$  termination. The termination may also be disabled for testing and other purposes.

**DATA DRIVER IMPEDANCE**

The Data Driver impedance (DZ) is used to determine the value of the data drivers impedance. When auto calibration is used the data driver impedance is set to RQ/6 and it's tolerance is determined by the calibration accuracy of the device. When any other value is selected the target impedance is set nominally to the desired impedance. However, the accuracy is now determined by the device's specific process corner, applied voltage and operating temperature.

**ADDITIVE LATENCY**

The Additive Latency function (AL) is used to optimize the command bus efficiency. The AL value is used to determine the number of clock cycles that is to be added to CL after CAS is captured by the rising edge of CK. Thus the total CAS latency is determined by adding CL and AL.

7.5 MANUFACTURERS VENDOR CODE AND REVISION IDENTIFICATION

The Manufacturers Vendor Code, V, is selected by issuing a EXTENDED MODE REGISTER SET command with bits A10 set to one, and bits A0-A9 and A11 set to the desired values. When the V function is enabled the GDDR3 SDRAM will provide its manufacturers vendor code on DQ[3:0] and revision identification on DQ[7:4]

Manufacturer	DQ[3:0]	Manufacturer	DQ[3:0]	Manufacturer	DQ[3:0]	Revision ID	DQ[7:4]
Reserved	0	Hynix	6	Reserved	C	G-die	0000
Samsung	1	Mosel	7	Reserved	D	I-die	1001
Infineon	2	Winbond	8	Reserved	E		
Elpida	3	ESMT	9	Micron	F		
Etron	4	Reserved	A				
Nanya	5	Reserved	B				

Vendor ID Read

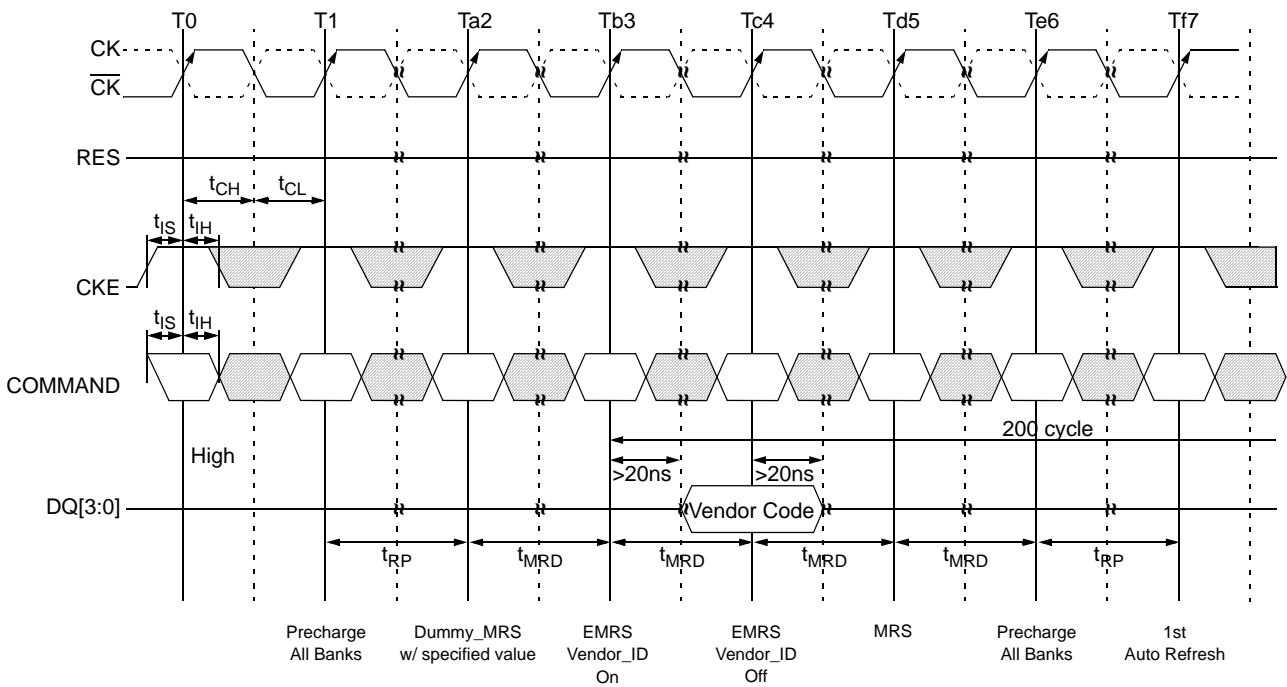

■ DON'T CARE □ TRANSITIONING DATA

7.6 Clock frequency change sequence during the device operation

Both existing tCK and desired tCK are in DLL-On mode

- Change frequency from existing frequency to desired frequency
- Issue Precharge All Banks command
- Issue MRS command to reset the DLL while other fields are valid and required 20K tCK to lock the DLL
- Issue Precharge All Banks command. Issue at least Auto-Refresh command

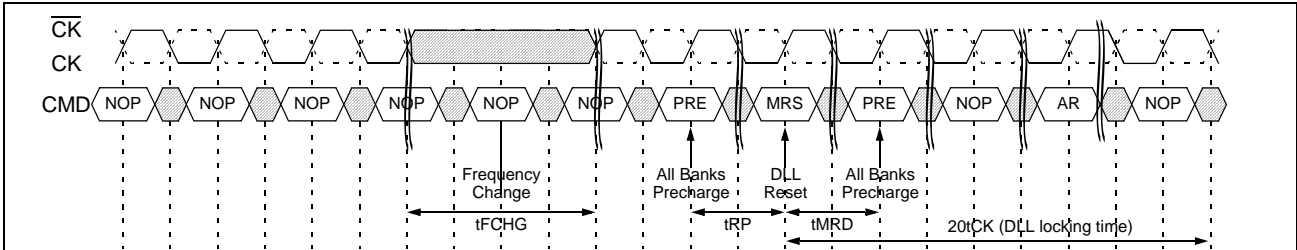

Existing tCK is in DLL-on mode while desired tCK is in DLL-off mode

- Issue Precharge All Banks command
- Issue EMRS command to disable the DLL
- Issue Precharge All Banks command
- Change the frequency from existing to desired.
- Issue Auto-Refresh command at least two. Issue MRS command

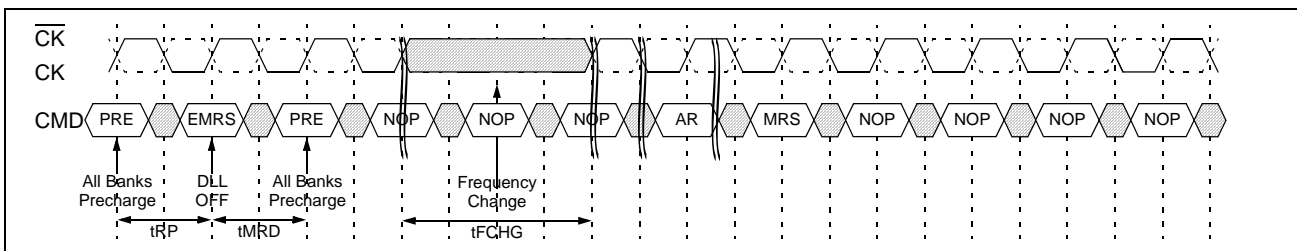

Clock frequency change in case existing tCK is in DLL-off mode while desired tCK is in DLL-on mode

- Issue Precharge All Banks command and issue EMRS command to disable the DLL.
- Issue Precharge All Banks command.
- Change the clock frequency from existing to desired
- Issue Precharge All Banks command.
- Issue EMRS command to enable the DLL
- Issue MRS command to reset the DLL and required 20K tCK to lock the DLL.
- Issue Precharge All Banks command.
- Issue Auto-Refresh command at least two

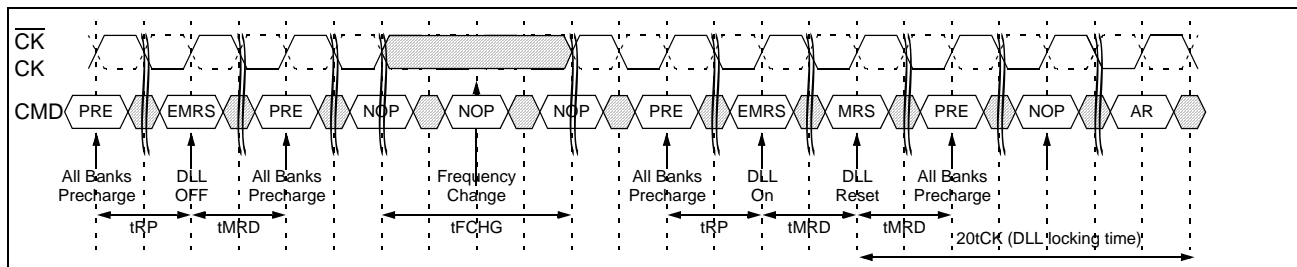

7.7 BOUNDARY SCAN FUNCTION

GENERAL INFORMATION

The 256Mb GDDR3 incorporates a modified boundary scan test mode as an optional feature. This mode doesn't operate in accordance with IEEE Standard 1149.1 - 1990. To save the current GDDR3 ball-out, this mode will scan parallel data input and output and the scanned data through WDQS0 pin controlled by an add-on pin, SEN which is located at V4 of 136 ball package. For the normal device operation other than boundary scan, there required device re-initialization by device power-off and then power-on.

DISABLING THE SCAN FEATURE

It is possible to operate the 256Mb GDDR3 without using the boundary scan feature. SEN(at V-4 of 136 ball package) should be tied LOW(VSS) to prevent the device from entering the boundary scan mode. The other pins which are used for scan mode, RES, MF, WDQS0 and CS# will be operating at normal GDDR3 function when SEN is de-asserted.

Figure 1. Internal Block Diagram (Reference Only)

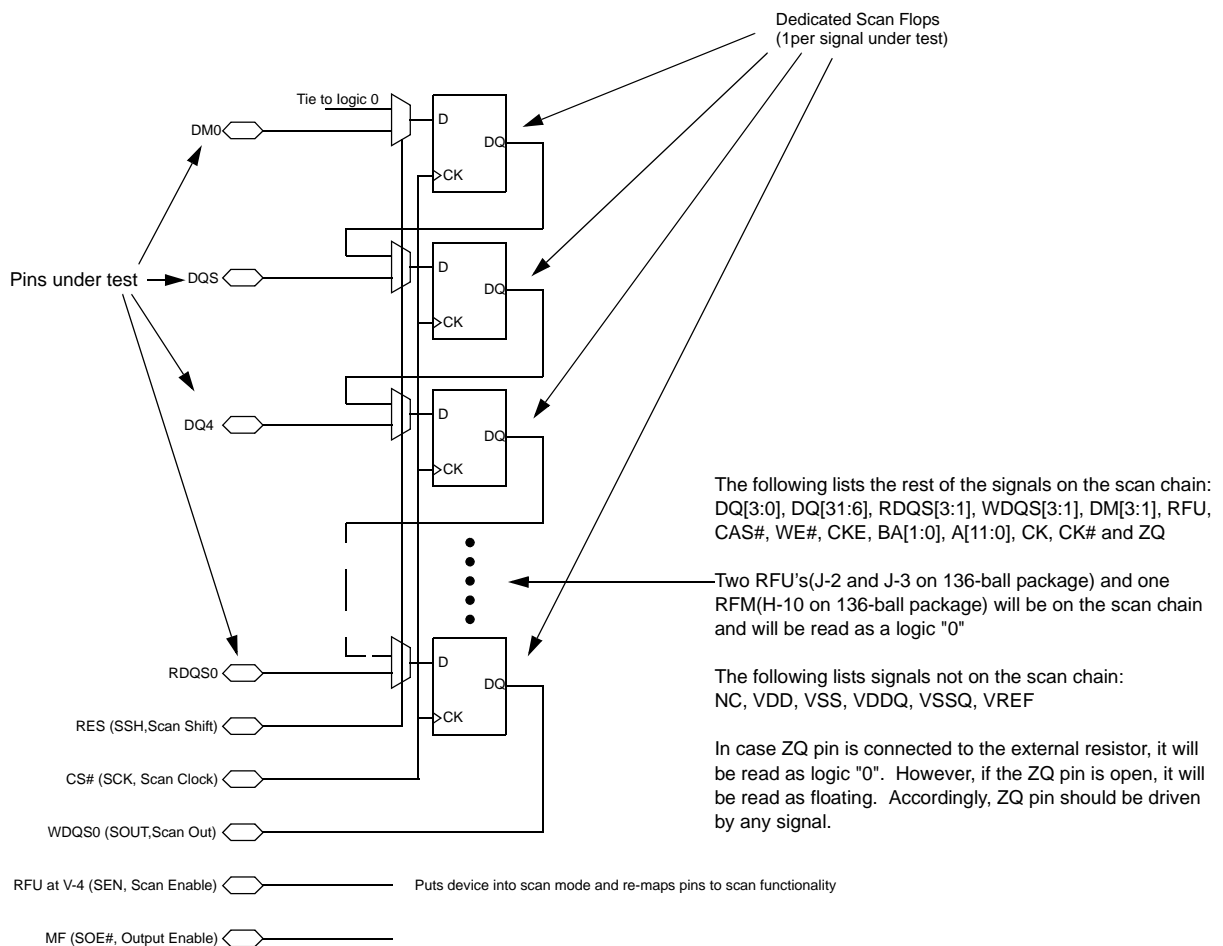

## BOUNDARY SCAN EXIT ORDER

BIT#	BALL	BIT#	BALL	BIT#	BALL	BIT#	BALL	BIT#	BALL	BIT#	BALL
1	D-3	13	E-10	25	K-11	37	R-10	49	L-3	61	G-4
2	C-2	14	F-10	26	K-10	38	T-11	50	M-2	62	F-4
3	C-3	15	E-11	27	K-9	39	T-10	51	M-4	63	F-2
4	B-2	16	G-10	28	M-9	40	T-3	52	K-4	64	G-3
5	B-3	17	F-11	29	M-11	41	T-2	53	K-3	65	E-2
6	A-4	18	G-9	30	L-10	42	R-3	54	K-2	66	F-3
7	B-10	19	H-9	31	N-11	43	R-2	55	L-4	67	E-3
8	B-11	20	H-10	32	M-10	44	P-3	56	J-3		
9	C-10	21	H-11	33	N-10	45	P-2	57	J-2		
10	C-11	22	J-11	34	P-11	46	N-3	58	H-2		
11	D-10	23	J-10	35	P-10	47	M-3	59	H-3		
12	D-11	24	L-9	36	R-11	48	N-2	60	H-4		

\*Note :

1. When the device is in scan mode, the mirror function will be disabled and none of the pins are remapped.
2. Since the other input of the MUX for DM0 tied to GND, the device will output the continuous zeros after scanning a bit #67, if the chip stays in scan shift mode.
3. Two RFU balls(#56and #57) and one RFM ball(#20) in the scan order will be read as a logic"0".

## SCAN PIN DESCRIPTION

Package Ball	Symbol	Normal Function	Type	Description
V-9	SSH	RES	Input	Scan shift. Capture the data input from the pad at logic LOW and shift the data on the chain at logic HIGH.
F-9	SCK	$\overline{CS}$	Input	Scan Clock. Not a true clock, could be a single pulse or series of pulses. All scan inputs will be referenced to rising edge of the scan clock.
D-2	SOUT	WDQS0	Output	Scan Output.
V-4	SEN	RFU	Input	Scan Enable. Logic HIGH would enable the device into scan mode and will be disabled at logic LOW. Must be tied to GND when not in use.
A-9	$\overline{SOE}$	MF	Input	Scan Output Enable. Enables (registered LOW) and disables (registered HIGH) SOUT data. This pin will be tied to VDD or GND through a resistor (typically 1K $\Omega$ ) for normal operation. Tester needs to overdrive this pin guarantee the required input logic level in scan mode.

\*Note :

1. When SEN is asserted, no commands are to be executed by the GDDR3 SDRAM. This applies to both user commands and manufacturing commands which may exist while RES is de-asserted.
2. All scan functionalities are valid only after the appropriate power-up and initialization sequence. (RES and CKE, to set the ODT of the C/A)
3. In scan mode, the ODT for the address and control lines set to a nominal termination value of ZQ. The ODT for DQ's will be disabled. It is not necessary for the termination to be calibrated.
4. In a double-load clam-shell configuration, SEN will be asserted to both devices. Separate two  $\overline{SOE}$ 's should be provided to top and bottom devices to access the scanned output. When either of the devices is in scan mode, SOE for the other device which not in a scan will be disabled.

SCAN DC ELECTRICAL CHARACTERISTICS AND OPERATING CONDITIONS

PARAMETER/CONDITON	SYMBOL	MIN	MAX	UNITS	NOTES
Input High (Logic 1) Voltage	$V_{IH}(DC)$	$V_{REF}+0.15$	-	V	1,2
Input Low (Logic 0) Voltage	$V_{IL}(DC)$	-	$V_{REF}-0.15$	V	1,2

\*Note : 1. The parameter applies only when SEN is asserted.  
 2. All voltages referenced to GND.

Figure 2. Scan Capture Timing

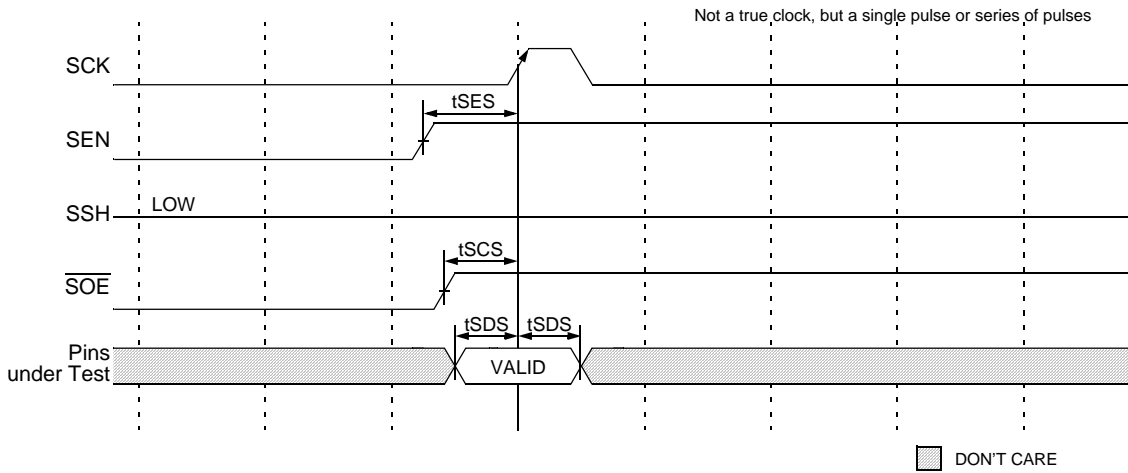
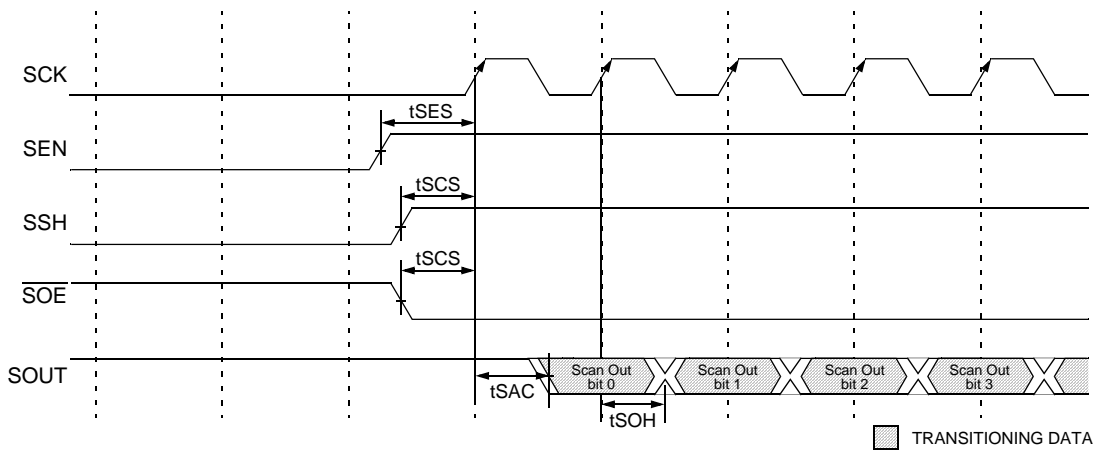

Figure 3. Scan Shift Timing



SCAN AC ELECTRICAL CHARACTERISTICS

PARAMETER/CONDITON	SYMBOL	MIN	MAX	UNITS	NOTES
<b>Clock</b>					
Clock cycle time	tSCK	40	-	ns	1
<b>Scan Command Time</b>					
Scan enable setup time	tSES	20	-	ns	1,2
Scan enable hold time	tSEH	20	-	ns	1
Scan command setup time for SSH, SOE# and SOUT	tSCS	14	-	ns	1
Scan command hold time for SSH, SOE# and SOUT	tSCH	14	-	ns	1
<b>Scan Capture Time</b>					
Scan capture setup Time	tSDS	10	-	ns	1
Scan capture hold Time	tSCH	10	-	ns	1
<b>Scan Shift Time</b>					
Scan clock to valid scan output	tSAC	-	6	ns	1
Scan clock to scan output hold	tSOH	1.5	-	ns	1

\*Note : 1. The parameter applies only when SEN is asserted.  
 2. Scan Enable should be issued earlier than other Scan Commands by 3ns.

Figure 4. Scan Initialization Sequence

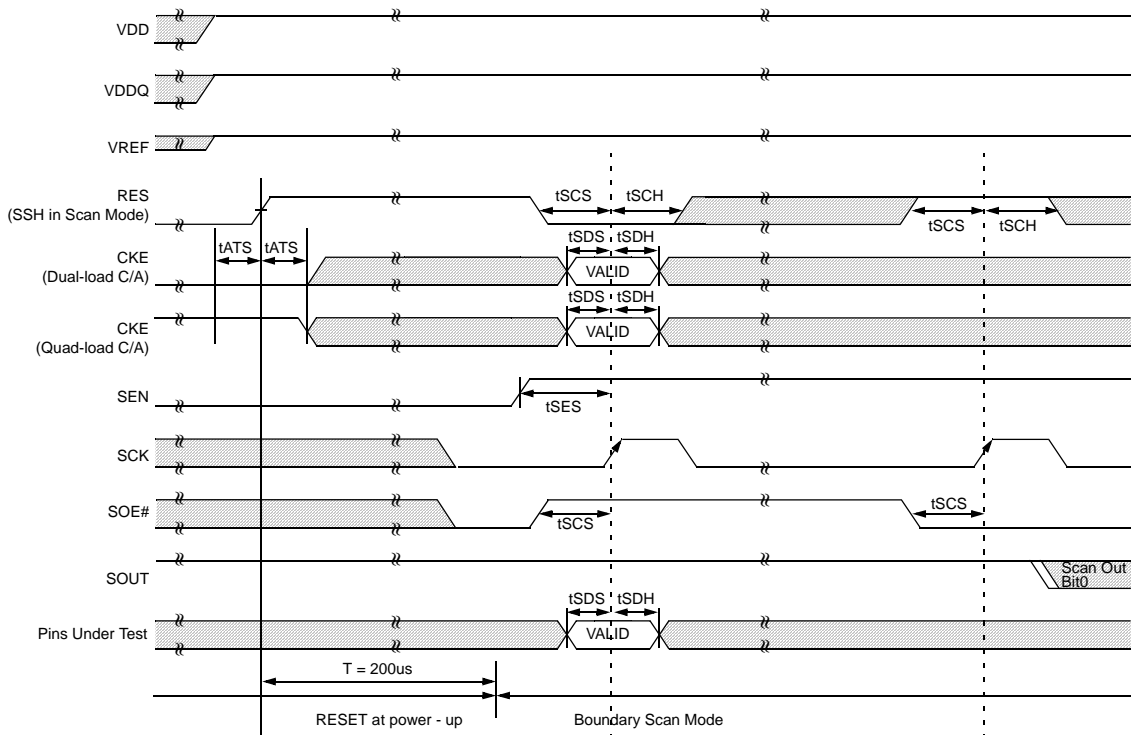

Note : To set the pre-defined ODT for C/A, a boundary scan mode should be issued after an appropriate ODT initialization sequence with RES and CKE signals

## 7.8 Mirror Function

The GDDR3 SDRAM provides a mirror function (MF) ball to change the physical location of the control lines and all address lines which helps to route devices back to back. The MF ball will affect  $\overline{\text{RAS}}$ ,  $\overline{\text{CAS}}$ ,  $\overline{\text{WE}}$ ,  $\overline{\text{CS}}$  and CKE on balls H3, F4, H9, F9 and H4 respectively and A0, A1, A2, A3, A4, A5, A6, A7, A8, A9, A10, A11, BA0 and BA1 on balls K4, H2, K3, M4, K9, H11, K10, L9, K11, M9, K2, L4, G4 and G9 respectively and only detects a DC input. The MF ball should be tied directly to VSS or VDD depending on the control line orientation desired. When the MF ball is tied low the ball orientation is as follows,  $\overline{\text{RAS}}$  - H3,  $\overline{\text{CAS}}$  - F4,  $\overline{\text{WE}}$  - H9,  $\overline{\text{CS}}$  - F9, CKE - H4, A0 - K4, A1 - H2, A2 - K3, A3 - M4, A4 - K9, A5 - H11, A6 - K10, A7 - L9, A8 - K11, A9 - M9, A10 - K2, A11 - L4, BA0 - G4 and BA1 - G9. The high condition on the MF ball will change the location of the control balls as follows;  $\overline{\text{CS}}$  - F4,  $\overline{\text{CAS}}$  - F9,  $\overline{\text{RAS}}$  - H10,  $\overline{\text{WE}}$  - H4, CKE - H9, A0 - K9, A1 - H11, A2 - K10, A3 - M9, A4 - K4, A5 - H2, A6 - K3, A7 - L4, A8 - K2, A9 - M4, A10 - K11, A11 - L9, BA0 - G9 and BA1 - G4.

**Mirror Function Signal Mapping**

PIN	MF LOGIC STATE	
	HIGH	LOW
RAS	H10	H3
CAS	F9	F4
WE	H4	H9
CS	F4	F9
CKE	H9	H4
A0	K9	K4
A1	H11	H2
A2	K10	K3
A3	M9	M4
A4	K4	K9
A5	H2	H11
A6	K3	K10
A7	L4	L9
A8	K2	K11
A9	M4	M9
A10	K11	K2
A11	L9	L4
BA0	G9	G4
BA1	G4	G9

7.9 OPERATIONS

7.9.1 BANK/ROW ACTIVATION

Before any READ or WRITE commands can be issued to a banks within the GDDR3 SDRAM, a row in that bank must be “opened.” This is accomplished via the ACTIVE command, which selects both the bank and the row to be activated.

After a row is opened with an ACTIVE command, a READ or WRITE command may be issued to that row, subject to the  $t_{RCD}$  specification.  $t_{RCD(min)}$  should be divided by the clock period and rounded up to the next whole number to determine the earliest clock edge after the ACTIVE command in which a READ or WRITE command can be entered. For example, a  $t_{RCD}$  specification of 16ns with a 800MHz clock (1.25ns period) results in 12.8 clocks rounded to 13. This is reflected in below figure, which covers any case where  $12 < t_{RCD(min)}/t_{CK} \leq 13$ .

The same procedure is used to convert other specification limits from time units to clock cycles).

A subsequent ACTIVE command to a different row in the same bank can only be issued after the previous active row has been “closed”(precharged). The minimum time interval between successive ACTIVE commands to the same bank is defined by  $t_{RC}$ .

A subsequent ACTIVE command to another bank can be issued while the first bank is being accessed, which results in a reduction of total row access overhead. The minimum time interval between successive ACTIVE commands to different banks is defined by  $t_{RRD}$ .

\* Any system or application incorporating random access memory products should be properly designed, tested and qualified to ensure proper use or access of such memory products. Disproportionate, excessive and/or repeated access to a particular address or addresses may result in reduction of product life.

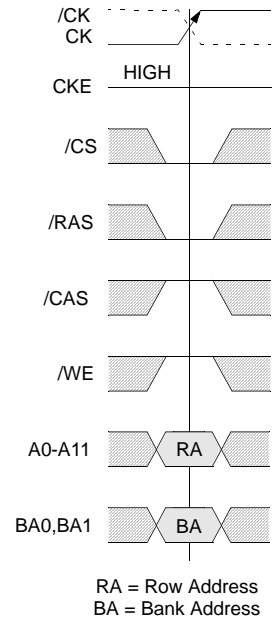

Activating a Specific Row in a Specific Bank

Example : Meeting  $t_{RCD}$

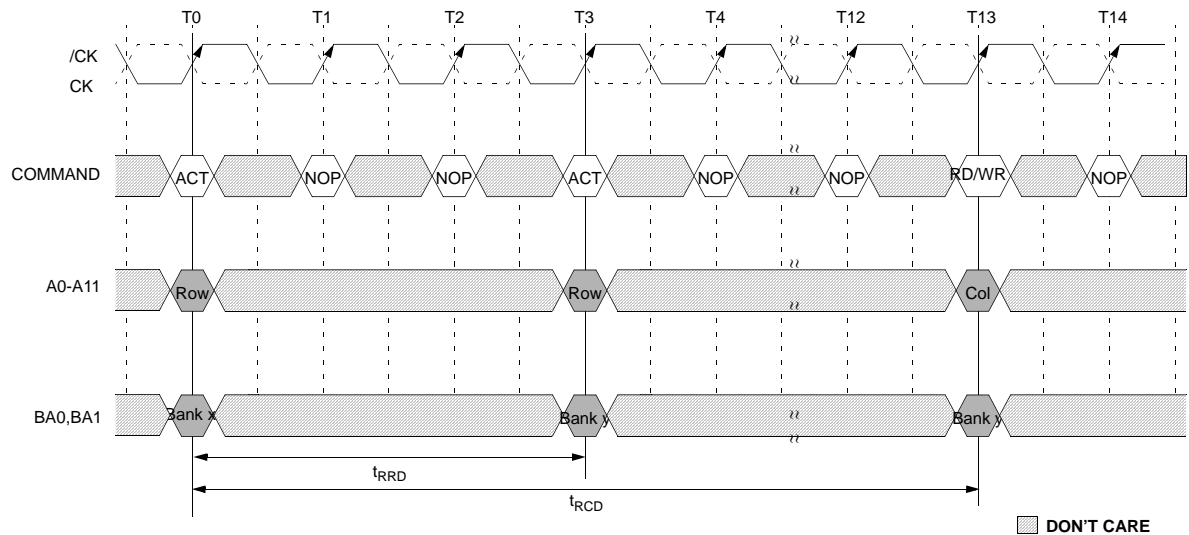

7.9.2 READs

READ bursts are initiated with a READ command, as below figure. The starting column and bank addresses are provided with the READ command and auto precharge is either enabled or disabled for that burst access. If auto precharge is enabled, the row being accessed is precharged at the completion of the burst after  $t_{RAS(min)}$  has been met. For the generic READ commands used in the following illustrations, auto precharge is disabled.

During READ bursts, the valid data-out element from the starting column address will be available following the CAS Latency after the READ command. Each subsequent data-out element will be valid nominally at the next positive or negative strobe edge. READ burst figure shows general timing for 2 of the possible CAS latency settings. The GDDR3(x32) drives the output data edge aligned to the crossing of CK and /CK and to RDQS. The initial HIGH transition LOW of RDQS is known as the read preamble ; the half cycle coincident with the last data-out element is known as the read postamble.

Upon completion of a burst, assuming no other commands have been initiated, the DQs will go High-Z. A detailed explanation of  $t_{DQSQ}$  (valid data-out skew),  $t_{DV}$  (data-out window hold), the valid data window are depicted in Data Output Timing (1) figure. A detailed explanation of  $t_{AC}$  (DQS and DQ transition skew to CK) is shown in Data Output Timing (2) figure.

Data from any READ burst may be concatenated with data from a subsequent READ command. A continuous flow of data can be maintained. The first data element from the new burst follows the last element of a completed burst. The new READ command should be issued x cycles after the first READ command, where x equals the number of data element nibbles (nibbles are required by the 4n-prefetch architecture) depending on the burst length. This is shown in consecutive READ bursts figure. Nonconsecutive read data is shown for illustration in nonconsecutive READ bursts figure. Full-speed random read accesses within a page (or pages) can be performed as shown in Random READ accesses figure. Data from a READ burst cannot be terminated or truncated.

During READ commands the GDDR3 Dram disables its data terminators.

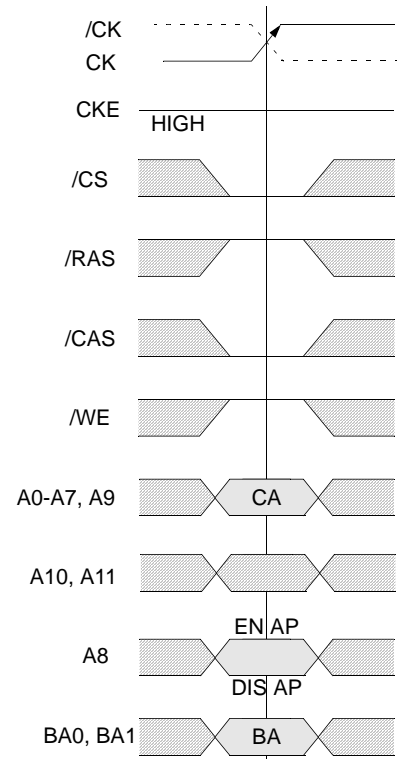

CA = Column Address  
 BA = Bank Address  
 EN AP = Enable Auto Precharge  
 DIS AP = Disable Auto Precharge

■ DON'T CARE

READ Command

Data Output Timing (1) -  $t_{DQSQ}$ ,  $t_{QH}$  and Data Valid Window

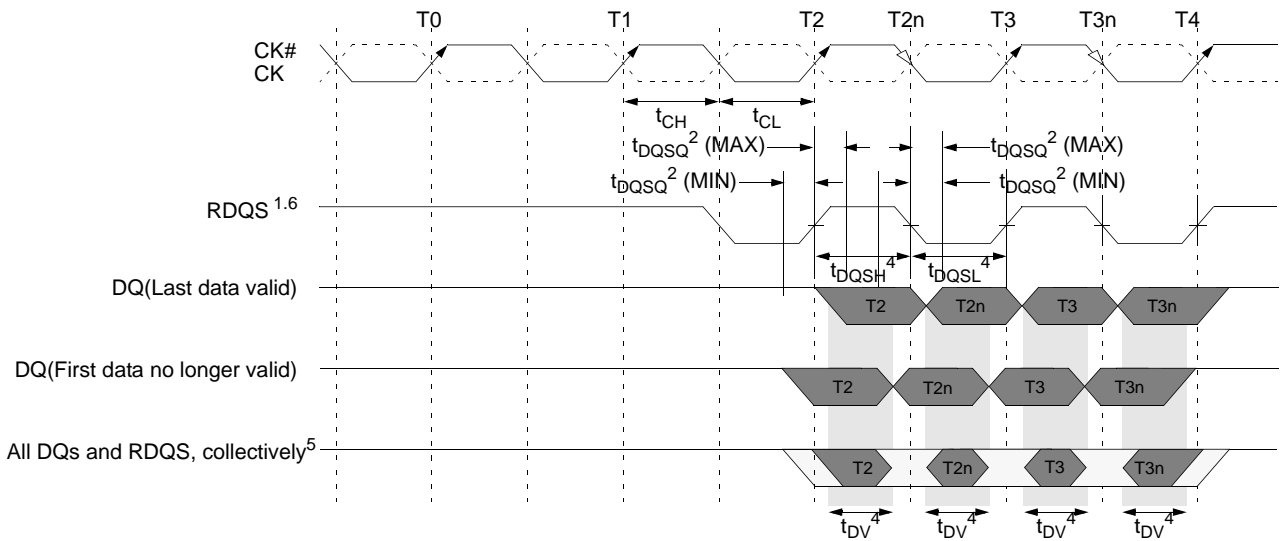

Data Output Timing (2) -  $t_{DQSQ}$ ,  $t_{QH}$  and Data Valid Window

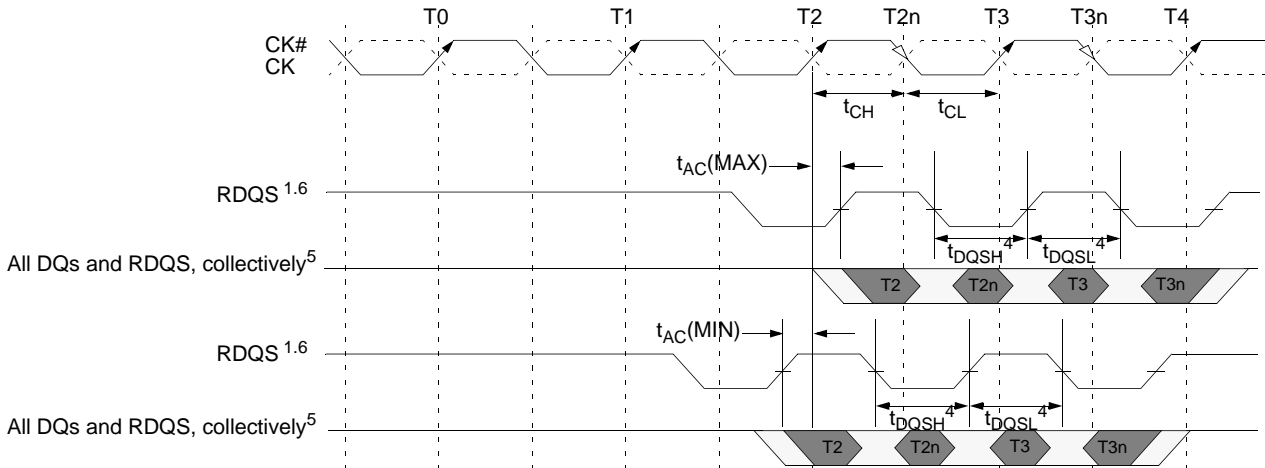

- Note :**
1.  $t_{DQSQ}$  represents the skew between the 8 DQ lines and the respective RDQS pin.
  2.  $t_{DQSQ}$  is derived at each RDQS clock edge and is not cumulative over time and begins with first DQ transition and ends with the last valid transition of DQs.
  3.  $t_{AC}$  is show in the nominal case
  4.  $t_{DQHP}$  is the lesser of  $t_{DQSL}$  or  $t_{DQSH}$  strobe transition collectively when a bank is active.
  5. The data valid window is derived for each RDQS transitions and is defined by  $t_{DV}$ .
  6. There are 4 RDQS pins for this device with RDQS0 in relation to DQ0-DQ7, RDQS1 in relation DQ8-DQ15, RDQS2 in relation to DQ16-24 and RDQS3 in relation to DQ25-DQ31.
  7. This diagram only represents one of the four byte lanes.
  8.  $t_{AC}$  represents the relationship between DQ, RDQS to the crossing of CK and /CK.

READ Burst

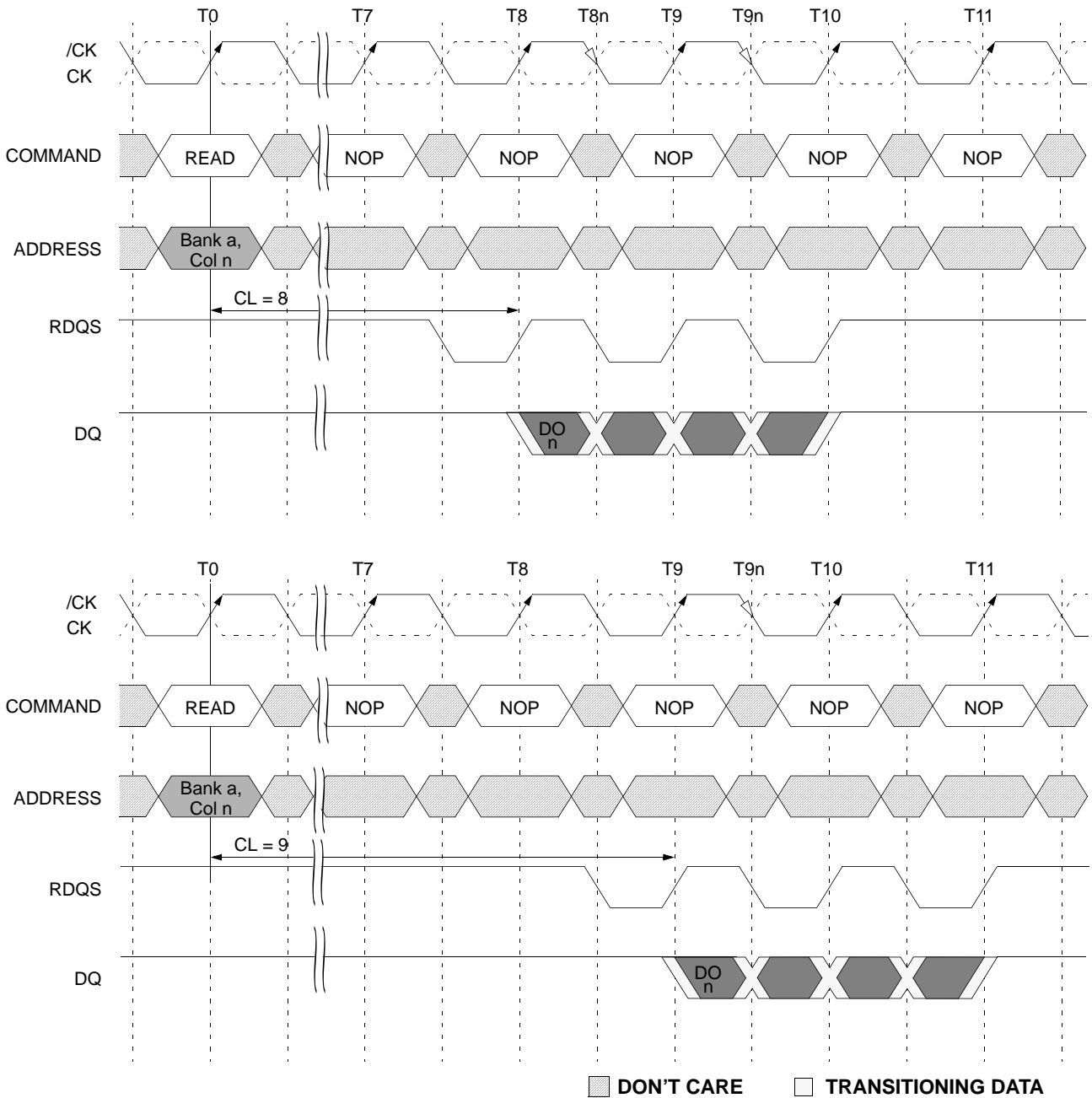

- NOTE :**
1. DO *n*=data-out from column *n*.
  2. Burst length = 4
  3. Three subsequent elements of data-out appear in the programmed order following DQ *n*.
  4. Shown with nominal  $t_{AC}$  and  $t_{DQSQ}$ .
  5. RDQS will start driving high 1/2 clock cycle prior to the first falling edge.

Consecutive READ Bursts

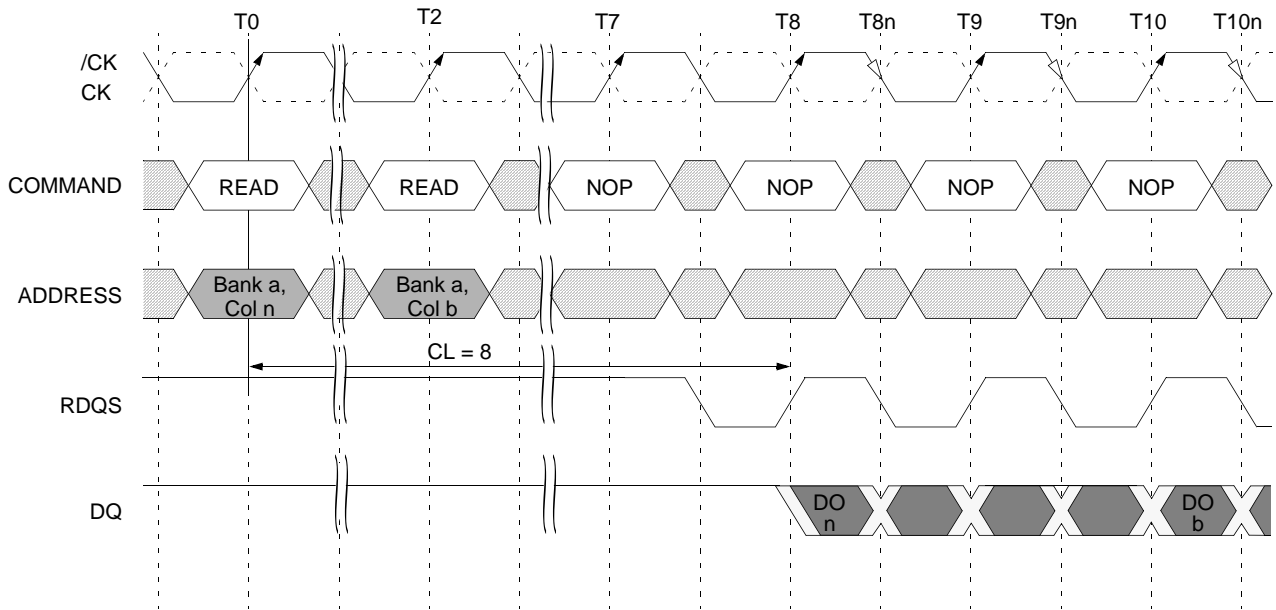

■ DON'T CARE □ TRANSITIONING DATA

- NOTE** :
1. DO *n* (or *b*) = data-out from column *n* (or column *b*).
  2. Burst length = 4
  3. Three subsequent elements of data-out appear in the programmed order following DQ *n*.
  4. Three subsequent elements of data-out appear in the programmed order following DQ *b*.
  5. Shown with nominal  $t_{AC}$  and  $t_{DQSQ}$ .
  6. Example applies when READ commands are issued to different devices or nonconsecutive READs.
  7. RDQS will start driving high one half-clock cycle prior to the first falling edge of RDQS.

Nonconsecutive READ Bursts

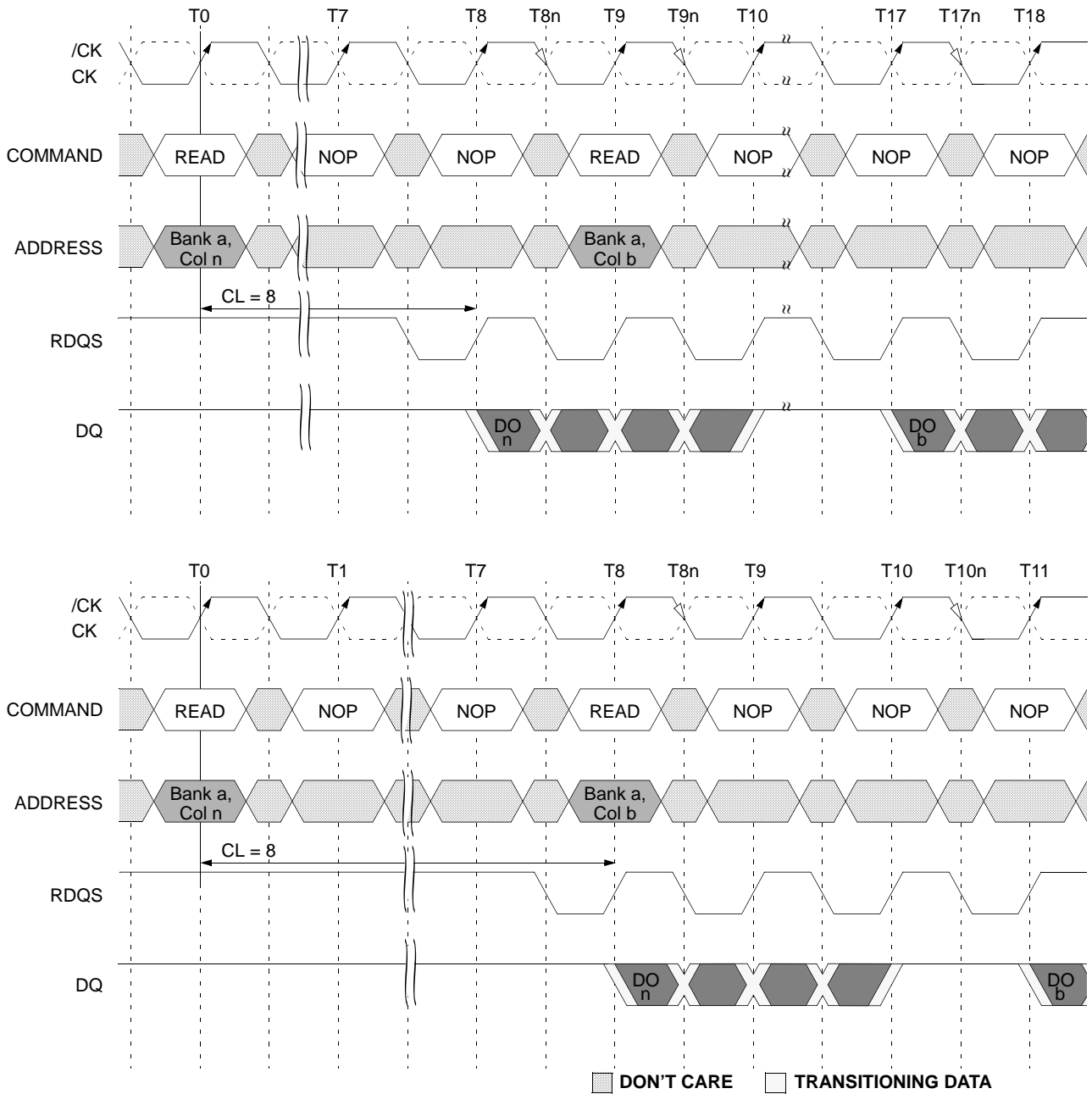

- NOTE :**
1. DO *n* (or *b*) = data-out from column *n* (or column *b*).
  2. Burst length = 4
  3. Three subsequent elements of data-out appear in the programmed order following DQ *n*.
  4. Three subsequent elements of data-out appear in the programmed order following DQ *b*.
  5. Shown with nominal  $t_{AC}$  and  $t_{DQSQ}$ .
  6. Example applies when READ commands are issued to different devices or nonconsecutive READs.
  7. RDQS will start driving high one half-clock cycle prior to the first falling edge of RDQS.

Random READ Accesses

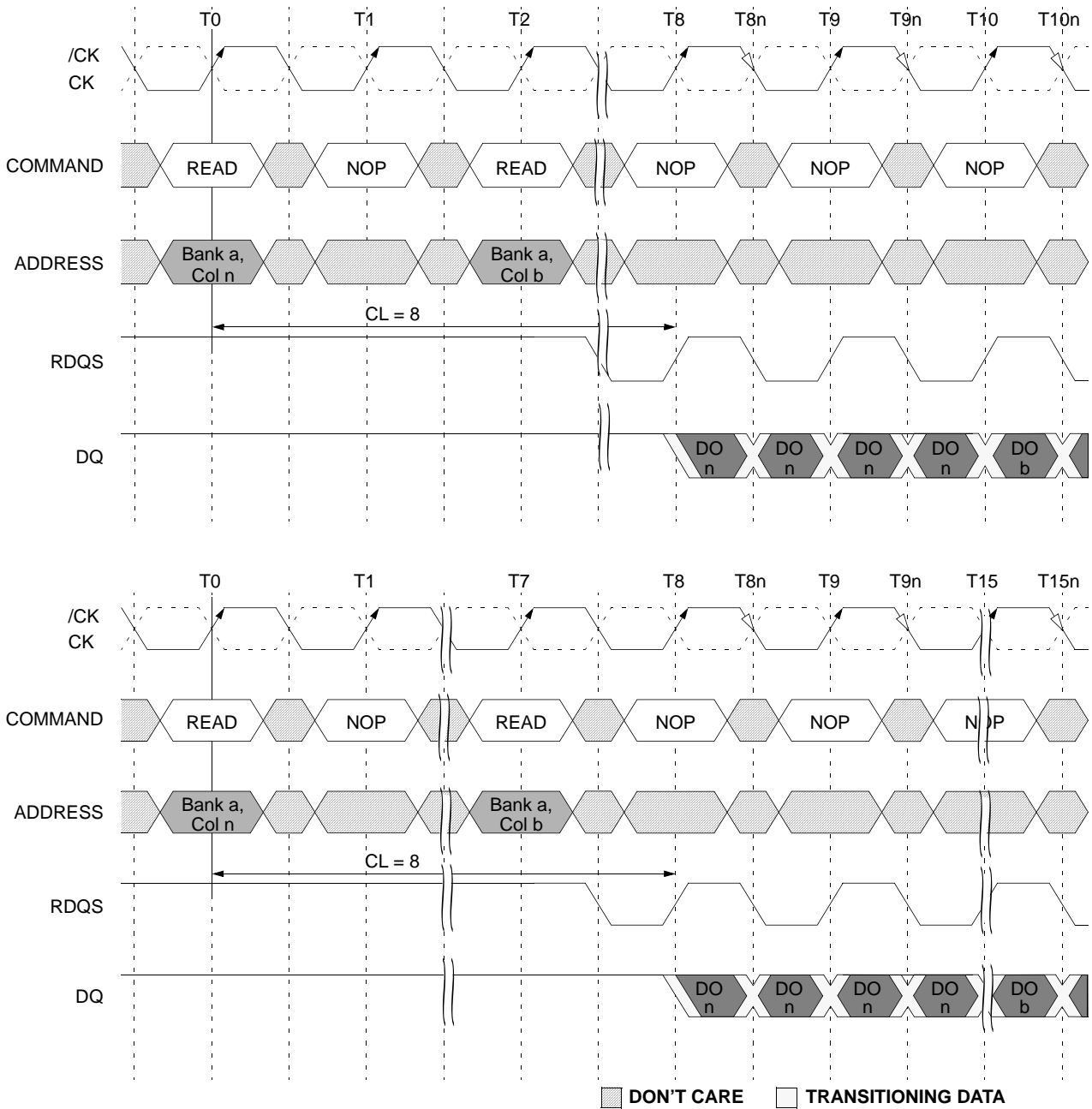

- NOTE :**
1. DO *n* (or *x* or *b* or *g*) = data-out from column *n* (or column *x* or column *x* or column *b* or column *g*).
  2. Burst length = 4
  3. *n'* or *x* or *b'* or *g'* indicates the next data-out following DO *n* or DO *x* or DO *b* OR DO *g*, respectively
  4. READs are to an active row in any bank.
  5. Shown with nominal  $t_{AC}$  and  $t_{DQSQ}$ .
  6. RDQS will start driving high one half-clock cycle prior to the first falling edge of RDQS.

READ to WRITE

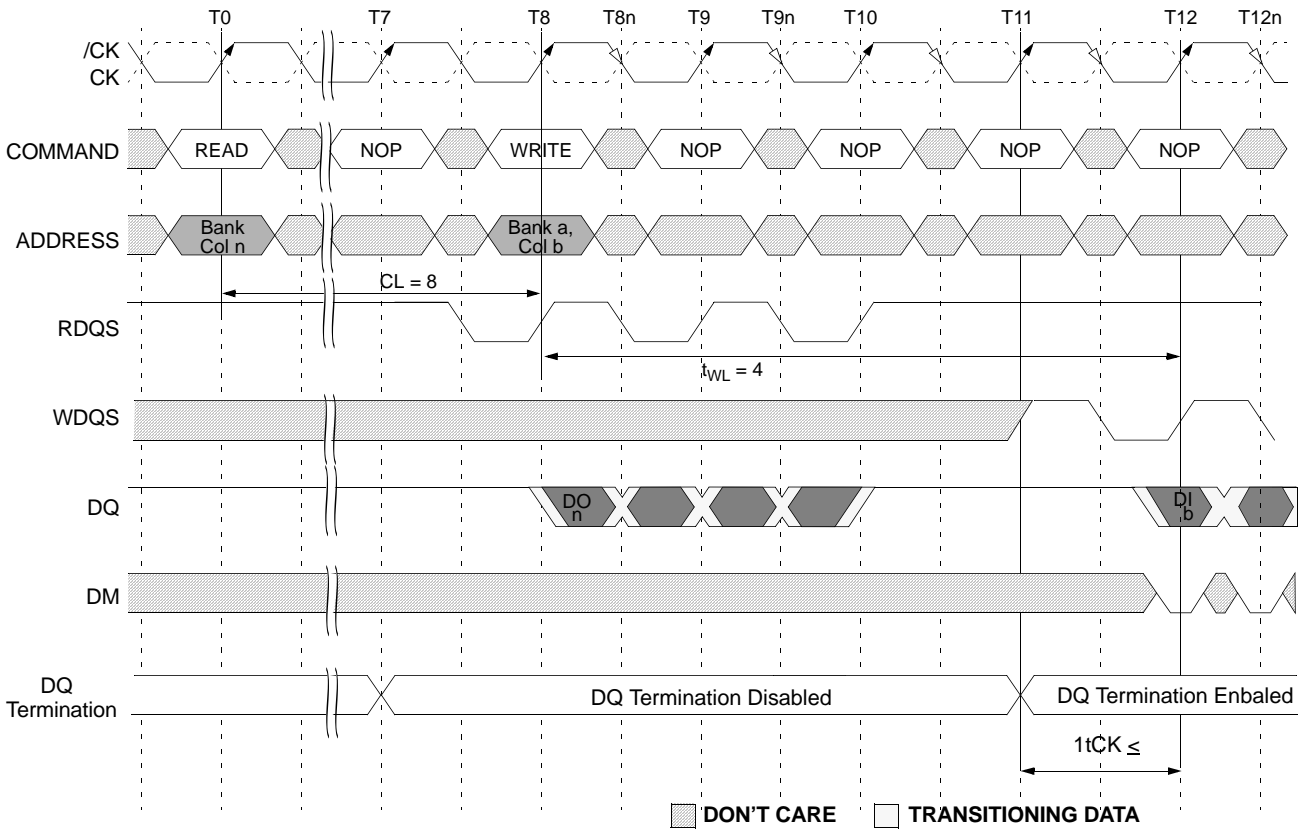

- NOTE :**
1. DO *n* = data-out from column *n*.
  2. DI *b* = data-in from column *b*.
  3. Burst length = 4
  4. One subsequent element of data-out appears in the programmed order following DO *n*.
  5. Data-in elements are applied following DI *b* in the programmed order.
  6. Shown with nominal  $t_{AC}$  and  $t_{DQSQ}$ .
  7.  $t_{DQSS}$  in nominal case.
  8. RDQS will start driving high one half-clock cycle prior to the first falling edge of RDQS.
  9. The gap between data termination enable to the first data-in should be greater than 1tCK

READ to PRECHARGE

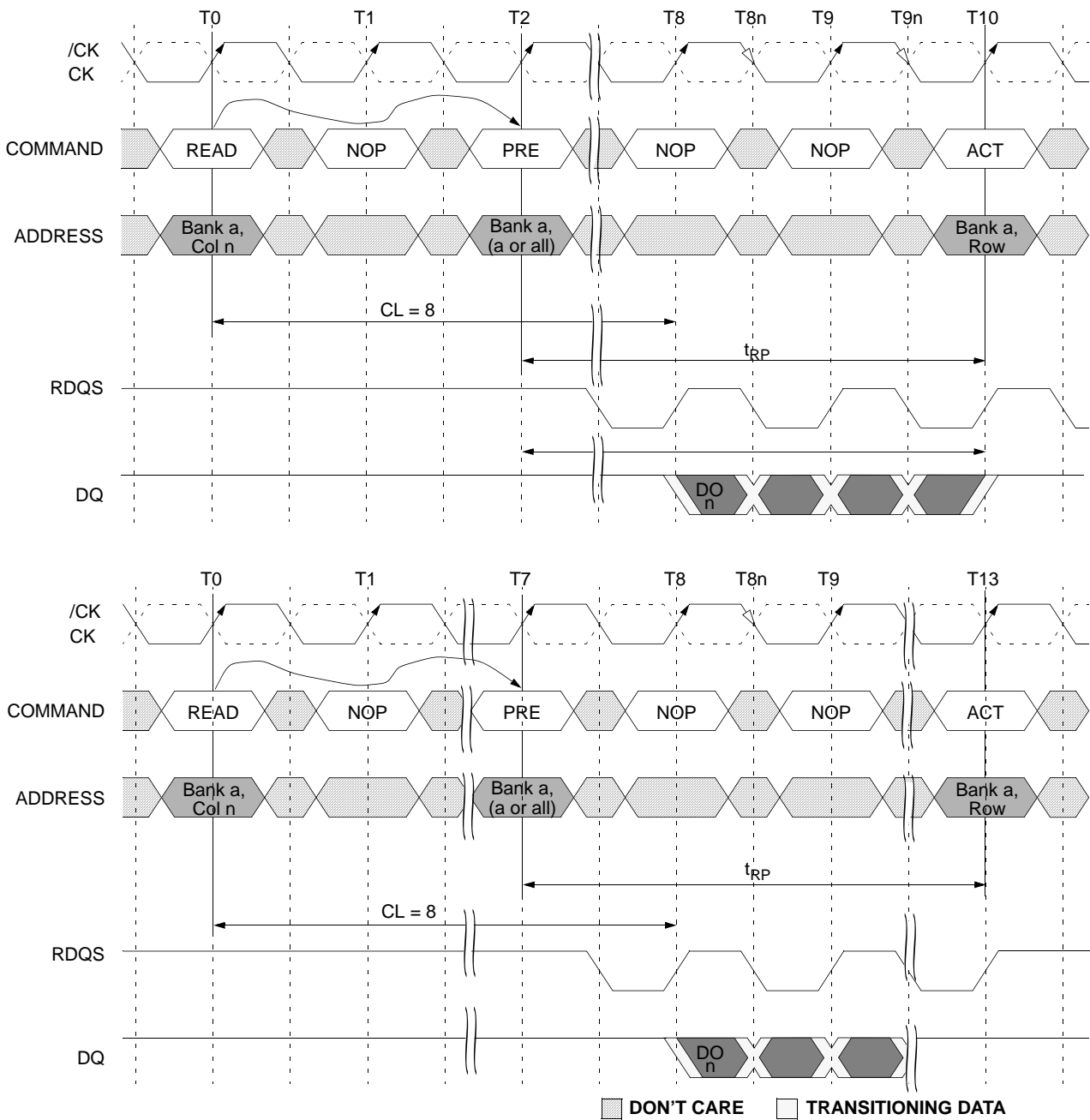

- NOTE:**
1. DO *n* (or *b*) = data-out from column *n* (or column *b*).
  2. Burst length = 4
  3. Three subsequent elements of data-out appear in the programmed order following DQ *n*.
  4. Three subsequent elements of data-out appear in the programmed order following DQ *b*.
  5. Shown with nominal t<sub>AC</sub> and t<sub>DQSQ</sub>.
  6. Example applies when READ commands are issued to different devices or nonconsecutive READS.
  7. RDQS will start driving high one half-clock cycle prior to the first falling edge of RDQS.

7.9.3 WRITES

WRITE bursts are initiated with a WRITE command, as shown in Figure. The starting column and bank addresses are provided with the WRITE command, and auto precharge is either enabled or disabled for that access. If auto precharge is enabled, the row being accessed is precharged at the completion of the burst. For the generic WRITE commands used in the following illustrations, auto precharge is disabled.

During WRITE bursts, the first valid data-in element will be registered in a rising edge of WDQS following the WRITE latency set in the mode register and subsequent data elements will be registered on successive edges of WDQS. Prior to the first valid WDQS edge a half cycle is needed and specified as the WRITE Preamble; the half cycle in WDQS following the last data-in element is known as the write postamble.

The time between the WRITE command and the first valid falling edge of WDQS ( $t_{DQSS}$ ) is specified with a relative to the write latency. All of the WRITE diagrams show the nominal case, and where the two extreme cases (i.e.,  $t_{DQSS(min)}$  and  $t_{DQSS(max)}$ ) might not be intuitive, they have also been included. Write Burst figure shows the nominal case and the extremes of  $t_{DQSS}$  for a burst of 4. Upon completion of a burst, assuming no other commands have been initiated, the DQs will remain High-Z and any additional input data will be ignored. Data for any WRITE burst may not be truncated with a subsequent WRITE command. The new WRITE command can be issued on any positive edge of clock following the previous WRITE command after the burst has completed. The new WRITE command should be issued  $x$  cycles after the first WRITE command should be equals the number of desired nibbles (nibbles are required by 4n-prefetch architecture).

An example of nonconsecutive WRITES is shown in Nonconsecutive WRITE to READ figure. Full-speed random write accesses within a page or pages can be performed as shown in Random WRITE cycles figure. Data for any WRITE burst may be followed by a subsequent READ command.

Data for any WRITE burst may be followed by a subsequent PRECHARGE command. To follow a WRITE the WRITE burst,  $t_{WR}$  should be met as shown in WRITE to PRECHARGE figure.

Data for any WRITE burst can not be truncated by a subsequent PRECHARGE command.

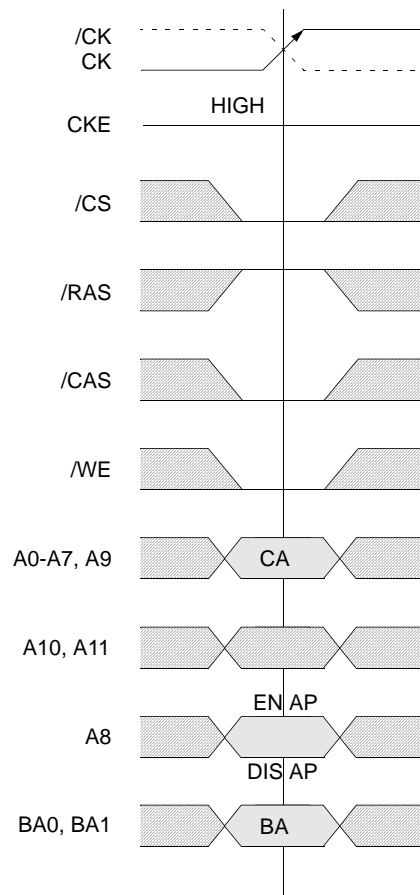

CA = Column Address  
 BA = Bank Address  
 EN AP = Enable Auto Precharge  
 DIS AP = Disable Auto Precharge

■ DON'T CARE

WRITE Command

WRITE Burst

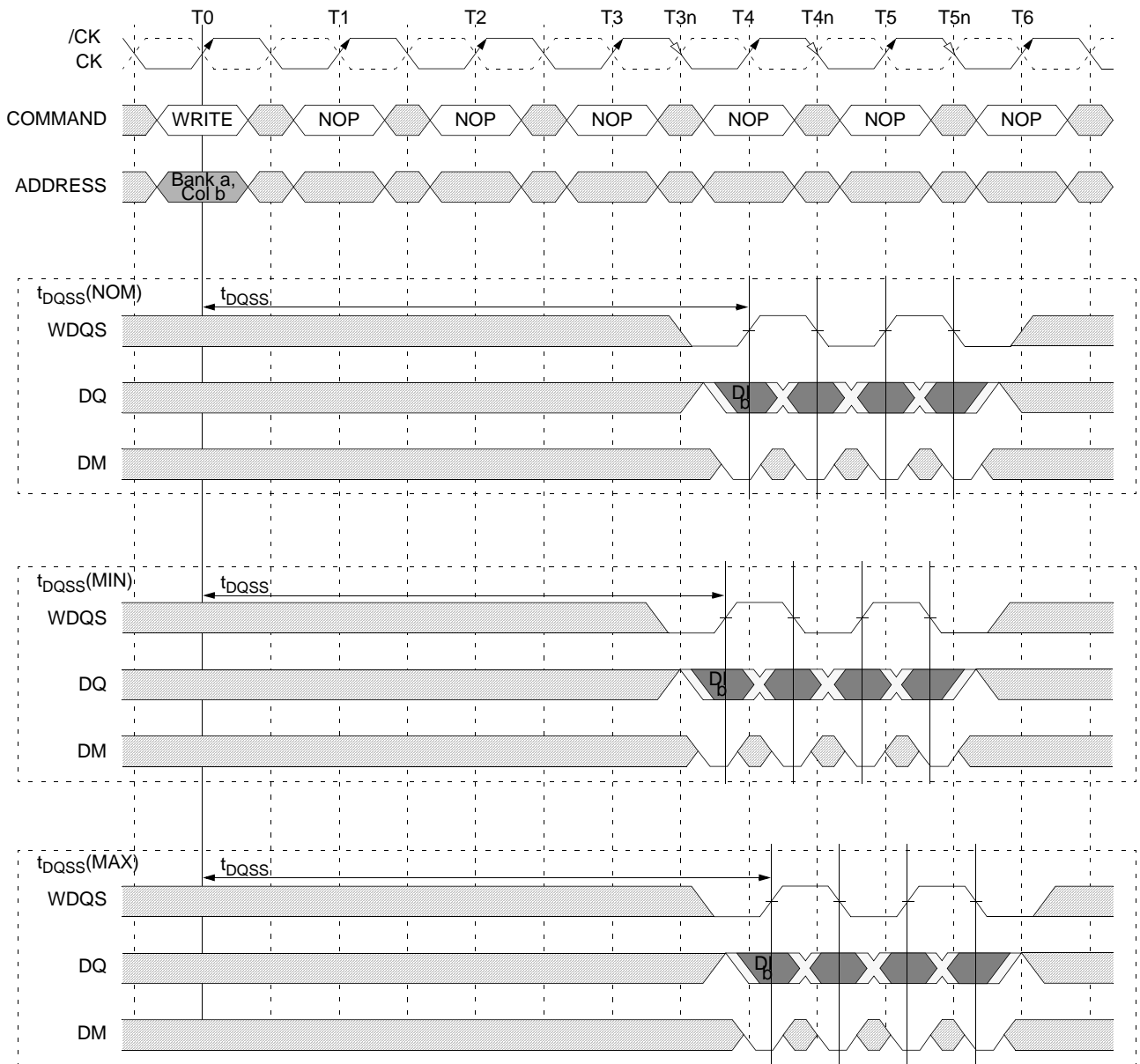

■ DON'T CARE □ TRANSITIONING DATA

- NOTE :**
1. DI b = data-in for column b.
  2. Three subsequent elements of data-in are applied in the programmed order following DI b.
  3. A burst of 4 is shown.
  4. A8 is LOW with the WRITE command (auto precharge is disabled).
  5. Write latency is set to 4

Consecutive WRITE to WRITE

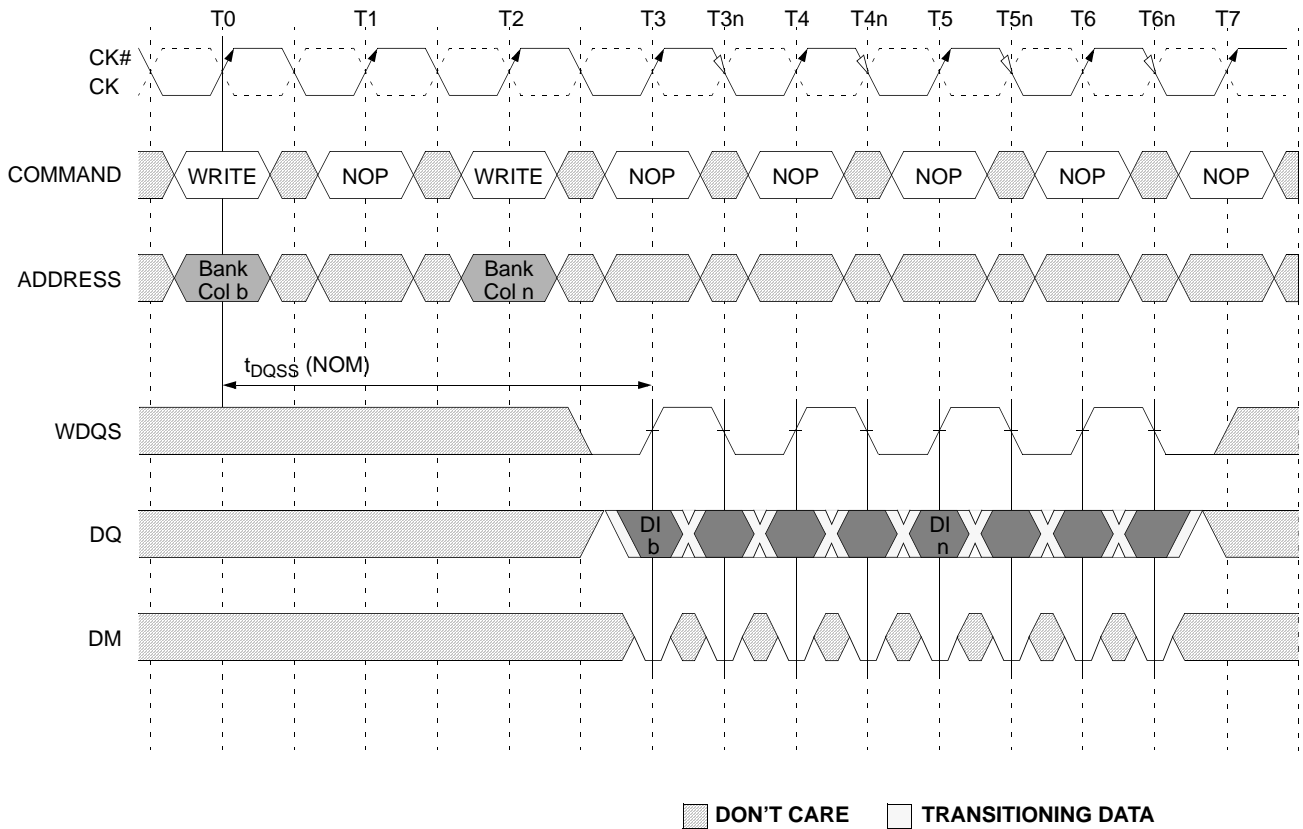

- NOTE:**
1. DI *b*, etc. = data-in for column *b*, etc.
  2. Three subsequent elements of data-in are applied in the programmed order following DI *b*.
  3. Three subsequent elements of data-in are applied in the programmed order following DI *n*.
  4. Burst of 4 is shown.
  5. Each WRITE command may be to any bank of the same device.
  6. Write latency is set to 3

Nonconsecutive WRITE to WRITE

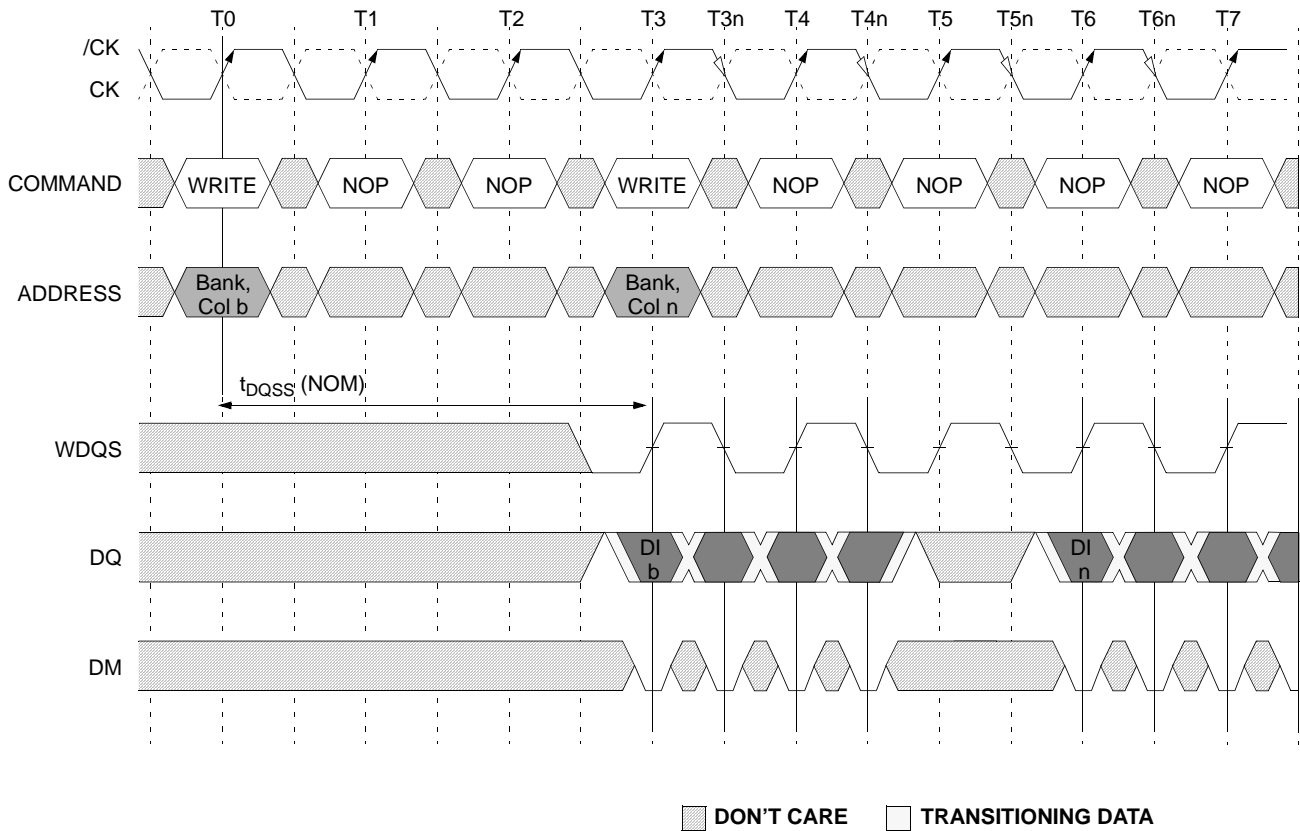

- NOTE:**
1. DI b, etc. = data-in for column b, etc.
  2. Three subsequent elements of data-in are applied in the programmed order following DI b.
  3. Three subsequent elements of data-in are applied in the programmed order following DI n.
  4. burst of 4 is shown.
  5. Each WRITE command may be to any bank.
  6. Write latency is set to 3

Random WRITE Cycles

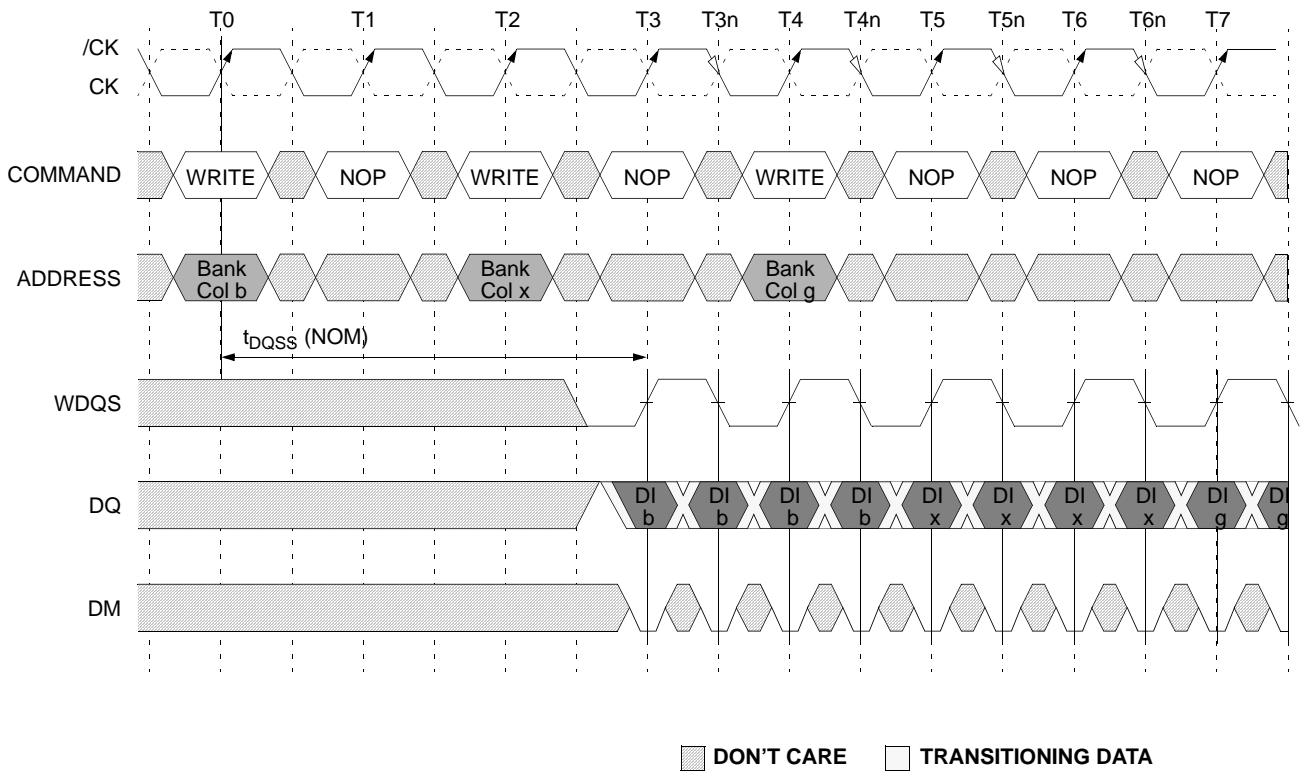

- NOTE :**
1. DI b, etc. = data-in for column b, etc.
  2. b: etc. = the next data - in following DI b. etc., according to the programmed burst order.
  3. Programmed burst length = 4 cases shown.
  4. Each WRITE command may be to any bank.
  5. Last write command will have the rest of the nibble on T8 and T8n
  6. Write latency is set to 3

WRITE to READ

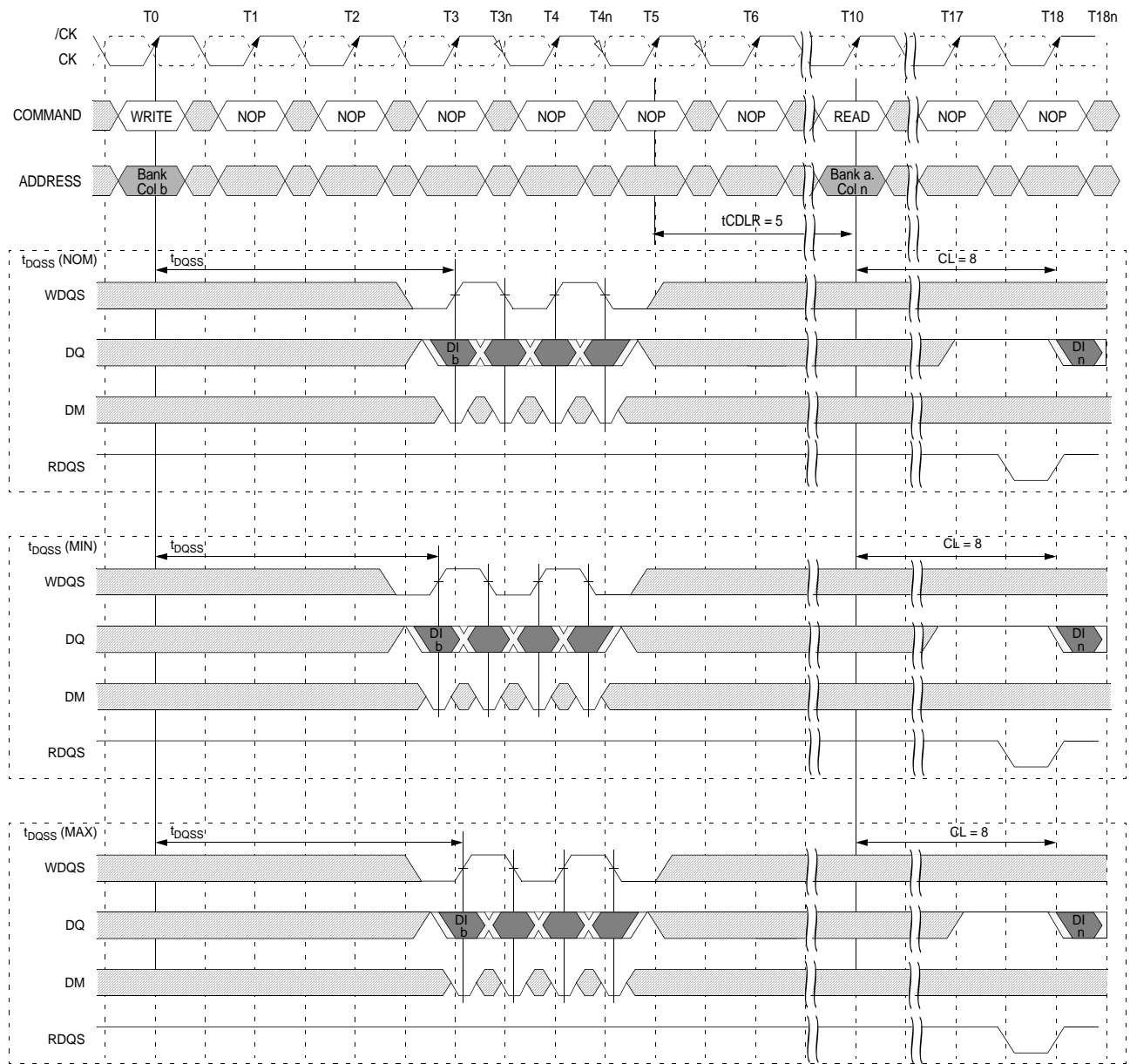

■ DON'T CARE □ TRANSITIONING DATA

- NOTE :**
1. DI *b* = data-in for column *b*.
  2. Three subsequent elements of data-in in the programmed order following DI *b*.
  3. A burst of 4 is shown.
  4.  $t_{CDLR}$  is referenced from the first positive CK edge after the last data-in pair.
  5. The READ and WRITE commands are to the same device. However, the READ and WRITE commands may be to different devices, in which case  $t_{CDLR}$  is not required and the READ command could be applied earlier.
  6. A8 is LOW with the WRITE command (auto precharge is disabled).
  7. WRITE latency is set to 3

WRITE to PRECHARGE

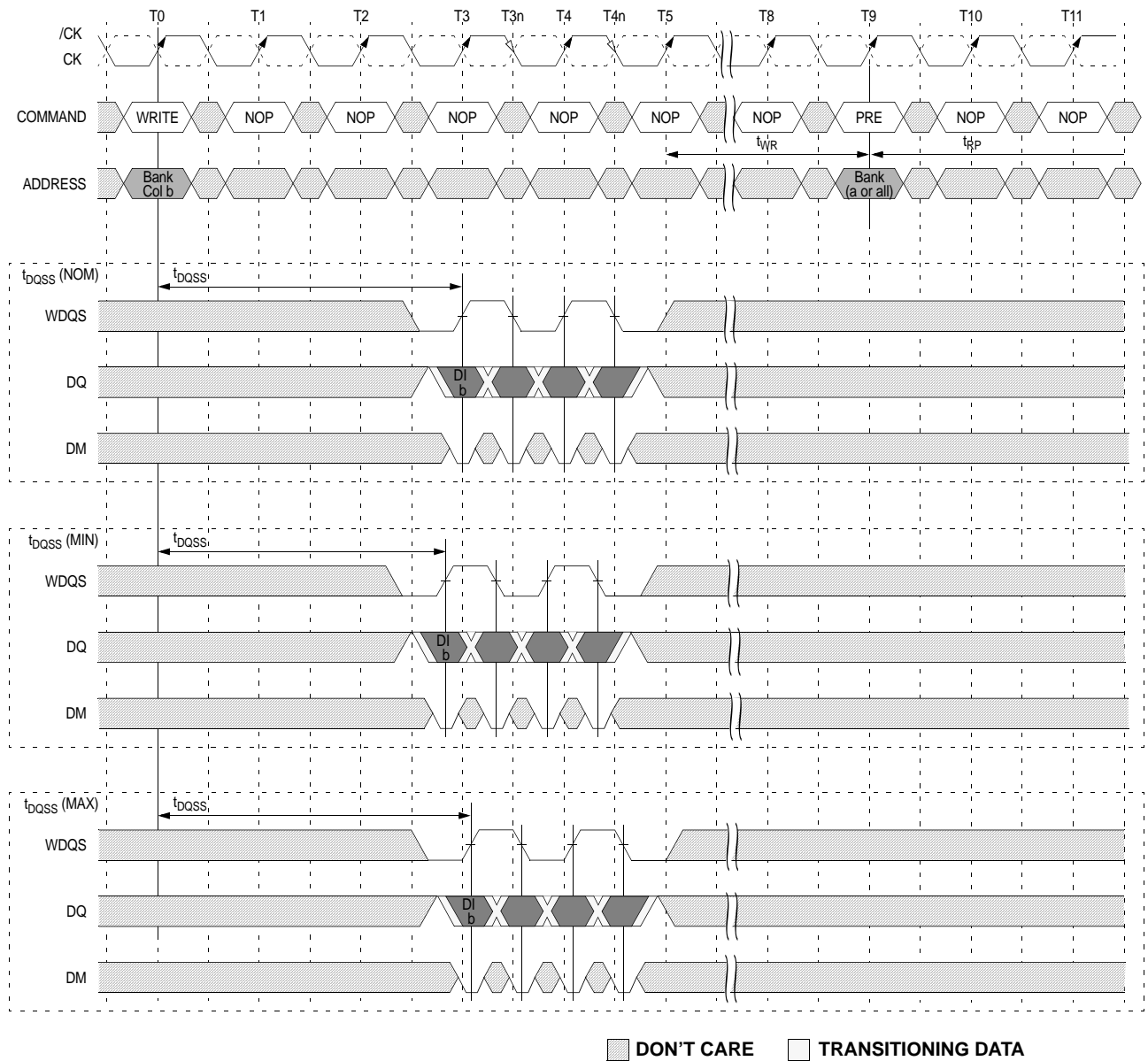

- NOTE:**
1. DI<sub>b</sub> = data-in for column *b*.
  2. Three subsequent elements of data-in the programmed order following DI<sub>b</sub>.
  3. A burst of 4 is shown.
  4. A8 is LOW with the WRITE command (auto precharge is disabled).
  5. WRITE latency is set to 3

**7.9.4 PRECHARGE**

The PRECHARGE command is used to deactivate the open row in a particular bank or the open row in all banks. The bank(s) will be available for a subsequent row access some specified time ( $t_{RP}$ ) after the PRECHARGE command is issued. Input A8 determines whether one or all banks are to be precharged, and in the case where only one bank is to be precharged, inputs BA0, BA1 select the bank. When all banks are to be precharged, inputs BA0, BA1 are treated as "Don't Care." Once a bank has been precharged, it is in the idle state and must be activated prior to any READ or WRITE commands being issued to the bank.

**7.9.5 POWER-DOWN (CKE NOT ACTIVE)**

Unlike SDR SDRAMs, GDDR3(x32) SDRAM requires CKE to be active at all times an access is in progress; from the issuing of a READ or WRITE command until completion of the burst. For READs, a burst completion is defined when the Read Postamble is satisfied; For WRITEs, a burst completion is defined BL/2 cycles after the Write Postamble is satisfied.

Power-down is entered when CKE is registered LOW. If power-down occurs when there is a row active in any bank, this mode is referred to as active power-down. Entering power-down deactivates the input and output buffers, excluding CK, /CK and CKE. For maximum power savings, the user has the option of disabling the DLL prior to entering power-down. However, power-down duration is limited by the refresh requirements of the device, so in most applications, the self-refresh mode is preferred over the DLL-disabled power-down mode.

When in power-down, CKE LOW and a stable clock signal must be maintained at the inputs of the GDDR3 SDRAM, while all other input signals are "Don't Care" except data terminator disable command.

The power-down state is synchronously exited when CKE is registered HIGH (in conjunction with a NOP or DESELECT command). A valid executable command may be applied  $t_{PDEX}$  later.

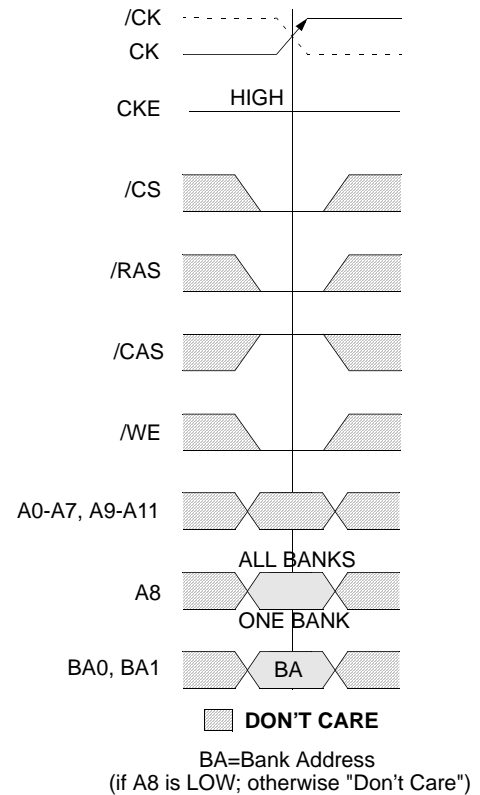

**Power-Down**

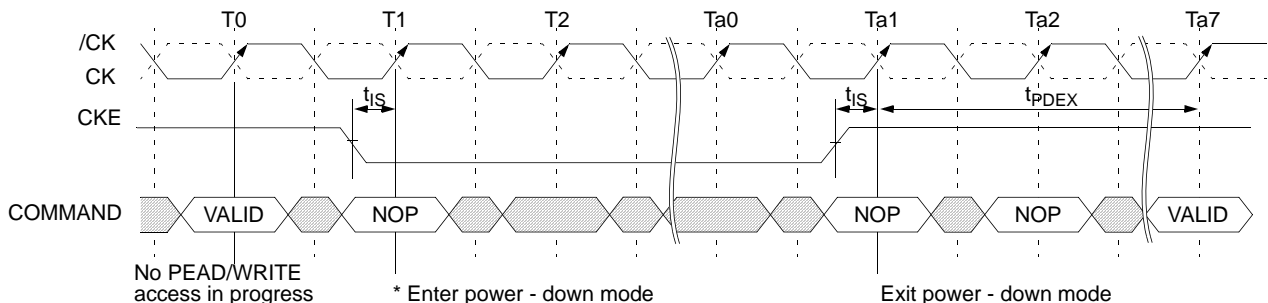

\* Once the device enters the power down mode, it should be in NOP state at least for 10ns

## 8.0 IBIS : I/V Characteristics for Input and Output Buffers

Voltage (V)	Pulldown Current (mA)		Pullup Current (mA)	
	Minimum	Maximum	Minimum	Maximum
0.1	2.8	3.2	-2.4	-3.1
0.2	5.5	9.6	-4.7	-6.2
0.3	8.1	12.8	-7.0	-9.2
0.4	10.8	15.9	-9.2	-12.1
0.5	13.3	19.0	-11.4	-14.9
0.6	15.8	22.0	-13.4	-17.7
0.7	18.2	25.1	-15.3	-20.3
0.8	20.5	28.0	-17.1	-22.8
0.9	22.8	31.0	-18.8	-25.2
1.0	24.9	33.8	-20.3	-27.5
1.1	26.9	36.7	-21.7	-29.6
1.2	28.8	36.7	-22.9	-31.6
1.3	30.6	39.4	-23.9	-33.3
1.4	32.2	42.1	-24.8	-34.9
1.5	33.7	44.7	-25.4	-36.3
1.6	35.2	47.0	-26.0	-37.5
1.7	36.3	49.2	-26.5	-38.3
1.8	37.7	51.4	-27.0	-39.3
1.9	38.7	53.3	-27.4	-40.0

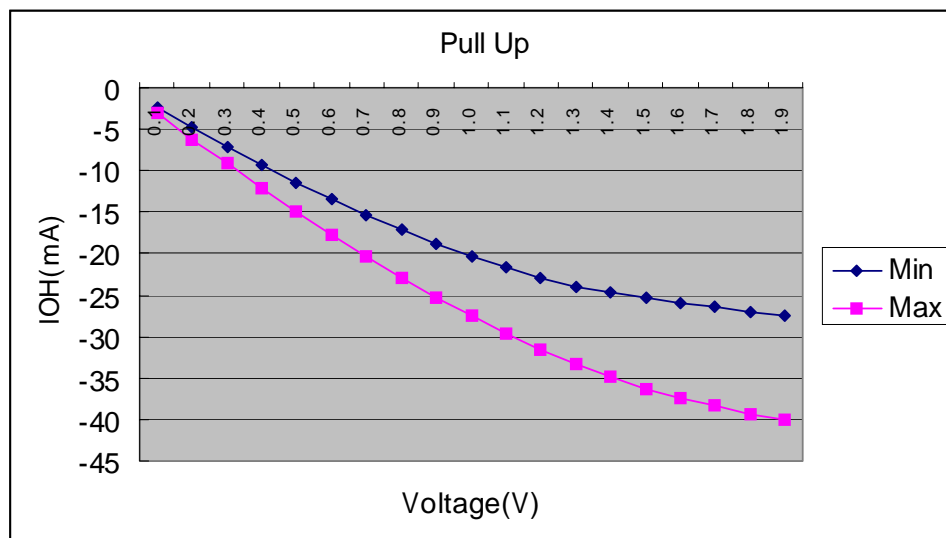
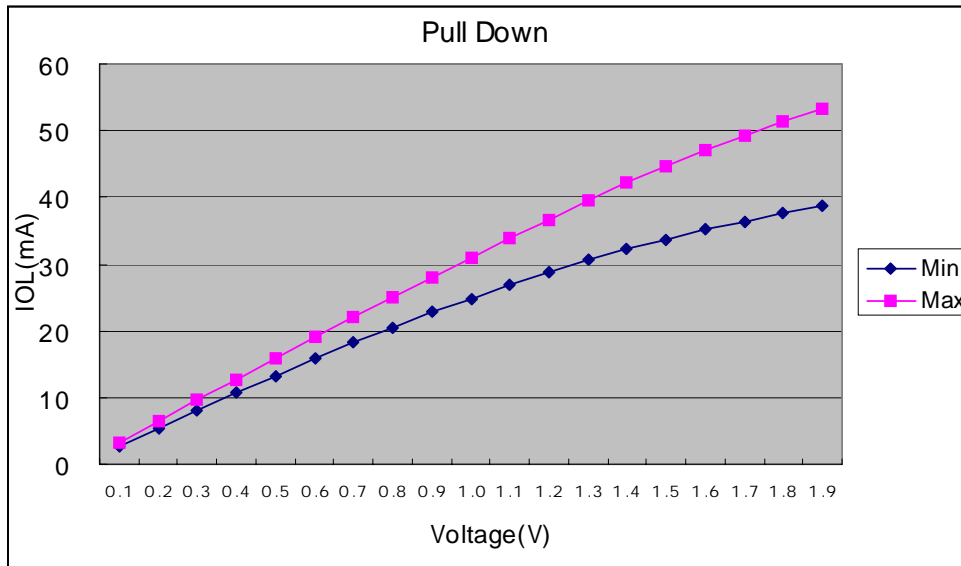

## 9.0 TRUTH TABLE

## TRUTH TABLE - Clock Enable (CKE)

CKEn-1	CKEn	CURRENT STATE	COMMANDn	ACTIONn	NOTES
L	L	Power-Down	X	Maintain Power-Down	
		Self Refresh	X	Maintain Self Refresh	
L	H	Power-Down	DESELECT or NOP	Exit Power-Down	
		Self Refresh	DESELECT or NOP	Exit Self Refresh	5
H	L	All Banks Idle	DESELECT or NOP	Precharge Power-Down Entry	
		Bank(s) Active	DESELECT or NOP	Active Power-Down Entry	
		All Banks Idle	AUTO REFRESH	Self Refresh Entry	

Note :

1. CKEn is the logic state of CKE at clock edge  $n$ ; CKEn-1 was the state of CKE at the previous clock edge.
2. Current state is the state of the GDDR3(x32) immediately prior to clock edge  $n$ .
3. COMMANDn is the command registered at clock edge  $n$ , and ACTIONn is a result of COMMANDn
4. All state and sequence not shown are illegal or reserved.
5. DESELECT or NOP commands should be issued on any clock edges occurring during the  $t_{XSA}$  period.

TRUTH TABLE - CURRENT STATE BANK  $n$  - COMMAND TO BANK  $n$ 

CURRENT STATE	/CS	/RAS	/CAS	/WE	COMMAND/ ACTION	NOTES
Any	H	X	X	X	DESELECT (NOP/ continue previous operation)	
	L	H	H	H	NO OPERATION (NOP/continue previous operation)	
	X	H	L	H	DATA TERMINATOR DISABLE	
Idle	L	L	H	H	ACTIVE (Select and activate row)	
	L	L	L	H	AUTO REFRESH	7
Row Active	L	L	L	L	LOAD MODE REGISTER	7
	L	H	L	H	READ (Select column and start READ burst)	10
	L	H	L	L	WRITE (Select Column and start WRITE burst)	10
	L	L	H	L	PRECHARGE (Deactivate row in bank or banks)	8
Read (Auto-Precharge Disable)	L	H	L	H	READ (Select column and start new READ burst)	10
	L	H	L	L	WRITE (Select column and start WRITE burst)	10, 12
	L	L	H	L	PRECHARGE (Only after the READ burst is complete)	8
Write (Auto-Precharge Disabled)	L	H	L	H	READ (Select column and start READ burst)	10, 11
	L	H	L	L	WRITE (Select column and start new WRITE burst)	10
	L	L	H	L	PRECHARGE (Only after the WRITE burst is complete)	8, 11

Note :

1. This table applies when  $CKE_{n-1}$  was HIGH and  $CKE_n$  is HIGH (see CKE Truth Table) and after  $t_{XSNR}$  has been met (if the previous state was self refresh).
2. This table is bank-specific, except where noted (i.e., the current state is for a specific bank and the commands shown are those allowed to be issued to that bank when in that state). Exceptions are covered in the notes below.
3. Current state definitions :
  - Idle : The bank has been precharged, and  $t_{RP}$  has been met.
  - Row Active : A row in the bank has been activated, and  $t_{RCD}$  has been met.  
No data bursts/accesses and no register accesses are in progress.
  - Read : A READ burst has been initiated, with auto precharge disabled.
  - Write : A WRITE burst has been initiated, with auto precharge disabled.
4. The following states must not be interrupted by a command issued to the same bank. COMMAND INHIBIT or NOP commands, or allowable commands to the other bank should be issued on any clock edge occurring during these states. Allowable commands to the other bank are determined by its current state and truth table- current state bank  $n$ -command to bank  $n$ . and according to truth table - current state bank  $n$ -command to bank  $m$ .
  - Precharging : Starts with registration of a PRECHARGE command and ends when  $t_{RP}$  is met.  
Once  $t_{RP}$  is met, the bank will be in the idle state.
  - Row Activating : Starts with registration of an ACTIVE command and ends when  $t_{RCD}$  is met.  
Once  $t_{RCD}$  is met, the bank will be in the :row active" state.

Read w/ Auto-Precharge Enabled : Starts with registration of an READ command with auto precharge enabled and ends when  $t_{RP}$  has been met. Once  $t_{RP}$  is met, the bank will be in the idle state.

Write w/ Auto-Precharge Enabled : Starts with registration of a WRITE command with auto precharge enabled and ends when  $t_{RP}$  has been met. Once  $t_{RP}$  is met, the bank will be in the idle state.

5. The following states must not be interrupted by any executable command ; COMMAND INHIBIT or NOP commands must be applied on each positive clock edge during these states.

Refreshing : Starts with registration of an AUTO REFRESH command and ends when  $t_{RC}$  is met.

Once  $t_{RC}$  is met, the GDDR3(x32) will be in the all banks idle state.

Accessing Mode : Starts with registration of a LOAD MODE REGISTER command and ends when  $t_{MRD}$

Register has been met. Once  $t_{MRD}$  is met, the GDDR3(x32) SDRAM will be in the all banks idle state.

Precharge All : Starts with registration of a PRECHARGE ALL command and ends when  $t_{RP}$  is met.

Once  $t_{RP}$  is met, all banks will be in the idle state.

READ or WRITE : Starts with registration of the ACTIVE command and ends the last valid data nibble.

6. All states and sequences not shown are illegal or reserved.
7. Not bank-specific; requires that all banks are idle, and bursts are not in progress.
8. May or may not be bank-specific ; If multiple banks are to be precharged, each must be in a valid state for precharging.

9. Left blank

10. READs or WRITEs listed in the Command/Action column include READs or WRITEs with auto precharge enabled and READs or WRITEs with auto precharge disabled.

11. Requires appropriate DM masking.

12. A WRITE command may be applied after the completion of the READ burst.

### TRUTH TABLE - CURRENT STATE BANK *n* - COMMAND TO BANK *m*

CURRENT STATE	/CS	/RAS	/CAS	/WE	COMMAND/ ACTION	NOTES
Any	H	X	X	X	DESELECT (NOP/ continue previous operation)	
	L	H	H	H	NO OPERATION (NOP/continue previous operation)	
	X	H	L	H	DATA TERMINATOR DISABLE	
Idle	X	X	X	X	Any Command Otherwise Allowed to Bank <i>m</i>	
Row Activating, Active, or Prechrging	L	L	H	H	ACTIVE (Select and activate row)	
	L	H	L	H	READ (Select column and start READ burst)	6
	L	H	L	L	WRITE (Select Column and start WRITE burst)	6
	L	L	H	L	PRECHARGE	
Read (Auto-Precharge Disable)	L	L	H	H	ACTIVE (Select and activate row)	
	L	H	L	H	READ (Select column and start new READ burst)	6
	L	H	L	L	WRITE (Select column and start WRITE burst)	6
	L	L	H	L	PRECHARGE	
Write (Auto-Precharge Disabled)	L	L	H	H	ACTIVE (Select and activate row)	
	L	H	L	H	READ (Select column and start READ burst)	6, 7
	L	H	L	L	WRITE (Select column and start new WRITE burst)	6
	L	L	H	L	PRECHARGE	
Read (With Auto-Precharge)	L	L	H	H	ACTIVE (Select and activate row)	
	L	H	L	H	READ (Select column and start new READ burst)	6
	L	H	L	L	WRITE (Select column and start WRITE burst)	6
	L	L	H	L	PRECHARGE	
Write (With Auto-Precharge)	L	L	H	H	ACTIVE (Select and activate row)	
	L	H	L	H	READ (Select column and start READ burst)	6
	L	H	L	L	WRITE (Select column and start new WRITE burst)	6
	L	L	H	L	PRECHARGE	

Note :

1. This table applies when  $CKE_{n-1}$  was HIGH and  $CKE_n$  is HIGH (see TRUTH TABLE- CKE ) and after  $t_{XSNR}$  has been met (if the previous state was self refresh).
2. This table describes alternate bank operation, except where noted (i.e., the current state is for bank *n* and the commands shown are those allowed to be issued to bank *m*, assuming that bank *m* is in such a state that the given command is allowable). Exceptions are covered in the notes below.

## 3. Current state definitions :

Idle : The bank has been precharged, and  $t_{RP}$  has been met.

Row Active : A row in the bank has been activated, and  $t_{RCD}$  has been met.  
No data bursts/accesses and no register accesses are in progress.

Read : A READ burst has been initiated, with auto precharge disabled.

Write : A WRITE burst has been initiated, with auto precharge disabled.

Read w/ Auto-Precharge Enabled : See following text

Write w/ Auto- Precharge Enabled : See following text

3a. The read with auto precharge enabled or write with auto precharge enabled states can each be broken into two parts : the access period and the precharge period. For read with auto precharge, the precharge period is defined as if the same burst was executed with auto precharge disabled and then followed with the earliest possible PRECHARGE command that still accesses all of the data in the burst. For write with auto precharge, the precharge period begins when  $t_{WR}$  ends, with  $t_{WR}$  command and ends where the precharge period (or  $t_{RP}$ ) begins. During the precharge period of the read with auto precharge enabled or write with auto precharge enabled states, ACTIVE, PRECHARGE, READ and WRITE commands to the other bank may be applied. In either case, all other related Limitations apply (e.g., contention between read data write data must be avoided).

3b. The minimum delay from a READ or WRITE command with auto precharge enabled, to a command to a different bank is summarized below.

From Command	To Command	Minimum delay (with concurrent auto precharge)
WRITE w/AP	READ or READ w/AP	$[WL + (BL/2)] t_{CK} + t_{WR}$
	WRITE or WRITE w/AP	$(BL/2) * t_{CK}$
	PRECHARGE	1 tCK
	ACTIVE	1 tCK
READ w/AP	READ or READ w/AP	$(BL/2) * t_{CK}$
	WRITE or WRITE w/AP	$[CLR_{U} + (BL/2)] + 1 - WL * t_{CK} + 1t_{CK}$
	PRECHARGE	1 tCK
	ACTIVE	1 tCK

4. AUTO REFRESH and LOAD MODE REGISTER commands may only be issued when all banks are idle.

5. All states and sequences not shown are illegal or reserved.

6. READs or WRITEs listed in the Command/Action column include READs or WRITEs with auto precharge enabled and READs or WRITEs with auto precharge disabled.

7. Requires appropriate DM masking.

## 10.0 COMMANDS

Below Truth table-COMMANDs provides a quick reference of available commands. This is followed by a verbal description of each command. Two additional Truth Tables appear following the operation section : these tables provide current state/next state information.

### TRUTH TABLE - COMMANDS

Name (Function)	CS	RAS	CAS	WE	ADDR	NOTES
DESELECT (NOP)	H	X	X	X	X	8, 11
NO OPERATION (NOP)	L	H	H	H	X	8
ACTIVE (Select bank and activate row)	L	L	H	H	Bank/Row	3
READ (Select bank and column, and start READ burst)	L	H	L	H	Bank/Col	4
WRITE (Select bank and column, and start WRITE burst)	L	H	L	L	Bank/Col	4
PRECHARGE (Deactivate row in bank or banks)	L	L	H	L	Code	5
AUTO REFRESH or SELF REFRESH (Enter self refresh mode)	L	L	L	H	X	6, 7
LOAD MODE REGISTER	L	L	L	L	Op-Code	2
DATA TERMINATOR DISABLE	X	H	L	H	X	

### TRUTH TABLE - DM Operation

Name (Function)	DM	DQS	NOTES
Write Enable	L	Valid	
Write Inhibit	H	X	10

Note :

1. CKE is HIGH for all commands except SELF REFRESH.
2. BA0 and BA1 select either the mode register or the extended mode register (BA0=0, BA1=0 select the mode register; BA0=1, BA1=0 select extended mode register; other combinations of BA0~BA1 are reserved). A0~A11 provide the op-code to be written to the selected mode register.
3. BA0 and BA1 provide bank address and A0~A11 provide row address.
4. BA0 and BA1 provide bank address; A0~A7 and A9 provide column address; A8 HIGH enables the auto precharge feature (nonpersistent) , and A8 LOW disables the auto precharge feature.
5. A8 LOW : BA0 and BA1 determine which banks are precharged.  
A8 HIGH : All banks are precharged.
6. This command is AUTO REFRESH if CKE is HIGH, SELF REFRESH if CKE is LOW.
7. Internal refresh counter controls row addressing; I/O inputs and I/Os are "Don't Care" except for CKE.
8. Deselect and NOP are functionally interchangeable.
9. Cannot be in powerdown or self-refresh state.
10. Used to mask write data ; provided coincident with the corresponding data.
11. Except DATA Termination disable.

### DESELECT

The Deselect function (/CS high) prevents new commands from being executed by the GDDR3(x32). The GDDR3(x32) SDRAM is effectively deselected. Operations already in progress are not affected.

### NO OPERATION (NOP)

The NO OPERATION (NOP) command is used to instruct selected GDDR3(x32) to perform a NOP (/CS LOW). This prevents unwanted commands from being registered during idle or wait states. Operations already in progress are not affected.

### LOAD MODE REGISTER

The mode registers are loaded via inputs A0-A11. See mode register descriptions in the Register Definition section. The Load Mode Register command can only be issued when all banks are idle, and a subsequent executable command cannot be issued until tMRD is met.

### ACTIVE

The ACTIVE command is used to open (or activate) a row in a particular bank for a subsequent access. The value on the BA0 and BA1 inputs selects the bank, and the address provided on inputs A0-A11 selects the row. This row remains active (or open) for accesses until a PRECHARGE command is issued to that bank. A PRECHARGE command must be issued before opening a different row in the same bank.

## READ

The READ command is used to initiate a burst read access to an active row. The value on the BA0 and BA1 inputs select the bank, and the address provided on inputs A0-A7, A9 selects the starting column location. The value on input A8 determines whether or not auto precharge is used. If auto precharge is selected, the row being accessed will be precharged at the end of the READ burst; if auto precharge is not selected, the row will remain open for subsequent accesses.

## WRITE

The WRITE command is used to initiate a burst write access to an active row. The value on the BA0 and BA1 inputs select the bank, and the address provided on inputs A0-A7, A9 selects the starting column location. The value on inputs A8 determines whether or not auto precharge is used. If auto precharge is selected, the row being accessed will be precharged at the end of the WRITE burst; if auto precharge is not selected, the row will remain open for subsequent accesses. Input data appearing on the DQs is written to the memory array subject to the DM input logic level appearing coincident with the data. If a given DM signal is registered LOW, the corresponding data will be written to memory; If the DM signal is registered HIGH, the corresponding data inputs will be ignored, and a WRITE will not be executed to that byte/column location.

## PRECHARGE

The PRECHARGE command is used to deactivate the open row in a particular bank or the open row in all banks. The bank(s) will be available for a subsequent row access a specified time ( $t_{RP}$ ) after the PRECHARGE command is issued. Input A8 determines whether one or all banks are to be precharged, and in the case where only one bank is to be precharged, inputs BA0,BA1 select the bank. Otherwise BA0, BA1 are treated as "Don't Care." Once a bank has been precharged, it is in the idle state and must be activated prior to any READ or WRITE command will be treated as a NOP if there is no open row is already in the process of precharging.

## AUTO PRECHARGE

Auto precharge is a feature which performs the same individual-bank precharge function described above, but without requiring an explicit command. This is accomplished by using A8 to enable auto precharge in conjunction with a specific READ or WRITE command. A precharge of the bank/row that is addressed with the READ or WRITE command is automatically performed upon completion of the READ or WRITE burst. Auto precharge is non persistent in that it is either enable or disabled for each individual READ or WRITE command. Auto precharge ensures that the precharge is initiated at the earliest valid state within a burst. This "earliest valid stage" is determined as if an explicit PRECHARGE command was issued at the earliest possible time, without violating  $t_{RAS(min)}$ , as described for each burst type in the Operation section of this data sheet. The user must not issue another command to the same bank until the precharge time( $t_{RP}$ ) is completed.

## AUTO REFRESH

Auto Refresh is used during normal operation of the GDDR3 SDRAM and is analogous to /CAS-BEFORE-/RAS (CBR) REFRESH in FPM/EDO DRAMs. This command is non persistent, so it must be issued each time a refresh is required. The addressing is generated by the internal refresh controller. This makes the address bits a "Don't Care" during an Auto Refresh command. The 256Mb(x32) GDDR3 requires Auto Refresh cycles at an average interval of 3.9us (maximum).

A maximum Auto Refresh commands can be posted to any given GDDR3(x32) SDRAM, meaning that the maximum absolute interval between any Auto Refresh command and the next Auto Refresh command is  $9 \times 3.9us(35.1us)$ . This maximum absolute interval is to allow GDDR3(x32) SDRAM output drivers and internal terminators to automatically re calibrate compensating for voltage and temperature changes.

## SELF REFRESH

The SELF REFRESH command can be used to retain data in the GDDR3(x32) SDRAM ,even if the rest of the system is powered down. When in the self refresh mode,the GDDR3(x32) SDRAM retains data without external clocking. The SELF REFRESH command is initiated like an AUTO REFRESH command except CKE is disabled (LOW). The DLL is automatically disabled upon entering SELF REFRESH and is automatically enabled and reset upon exiting SELF REFRESH. The active termination is also disabled upon entering Self Refresh and enabled upon exiting Self Refresh. (20K clock cycles must then occur before a READ command can be issued). Input signals except CKE are "Don't Care" during SELF REFRESH. The procedure for exiting self refresh requires a sequence of commands. First, CK and /CK must be stable prior to CKE going back HIGH. Once CKE is HIGH,the GDDR3(x32) must have NOP commands issued for  $t_{XSNR}$  because time is required for the completion of any internal refresh in progress. A simple algorithm for meeting both refresh, DLL requirements and out-put calibration is to apply NOPs for 20K clock cycles before applying any other command to allow the DLL to lock and the output drivers to recalibrate.

## DATA TERMINATION DISABLE (BUS SNOOPING FOR READ COMMAND)

The DATA TERMINATOR DISABLE COMMAND is detected by the device by snooping the bus for READ commands excluding /CS. The GDDR3 DRAM will disable its Data terminators when a READ command is detected. The terminators are disabled CL-1 Clocks after the READ command is detected. In a two rank system both dram devices will snoop the bus for READ commands to either device and both will disable their terminators if a READ command is detected. The command and address terminators are always enabled.

## ON-DIE TERMINATION

Bus snooping for READ commands other than /CS is used to control the on-die termination in the dual load configuration. The GDDR3 SDRAM will disable the on-die termination when a READ command is detected, regardless of the state of /CS, when the ODT for the DQ pins are set for dual loads ( $120\Omega$ ). The on-die termination is disabled x clocks after the READ command where x equals CL-1 and stay off for a duration of  $BL/2 + 2$ , as below figure, Data Termination Disable Timing. In a two-rank system, both DRAM devices snoop the bus for READ commands to either device and both will disable the on-die termination if a READ command is detected. The on-die termination for all other pins on the device are always on for both a single-rank system and a dual-rank system.

The on-die termination value on address and control pins is determined during power-up in relation to the state of CKE on the first transition of RESET. On the rising edge of RESET, if CKE is sampled LOW, then the configuration is determined to be a single-rank system. The on-die termination is then set to one-half ZQ for the address pins. On the rising edge of RESET, if CKE is sampled HIGH, then the configuration is determined to be a dual-rank system. The on-die termination for the DQs, WDQS, and DM pins is set in the EMRS.

### Data Termination Disable Timing

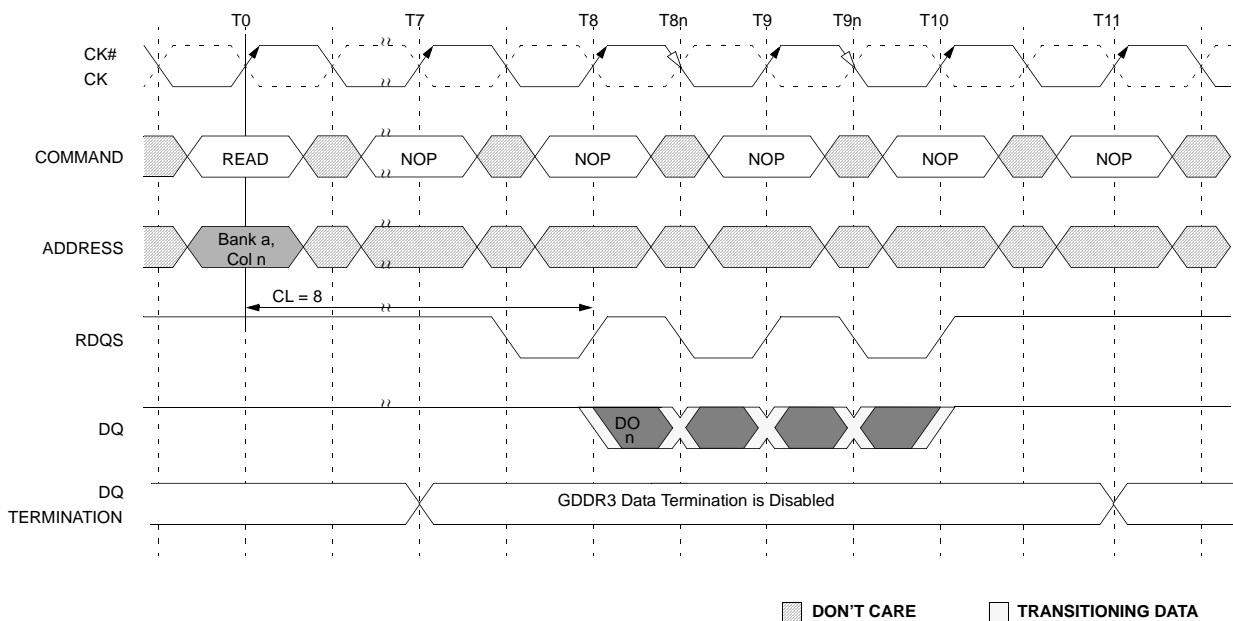

- Note :**
1. DO  $n$  = data-out from column  $n$ .
  2. Burst length = 4.
  3. Three subsequent elements of data-out appear in the specified order following DO  $n$ .
  4. Shown with nominal  $t_{AC}$  and  $t_{DQSQ}$ .
  5. RDQS will start driving high one-half cycle prior to the first falling edge.
  6. The Data Terminators are disabled starting at CL-1 and the duration is  $BL/2 + 2$
  7. READS to either rank disable both ranks' termination regardless of the logic level of /CS.

## 11.0 AC & DC OPERATING CONDITIONS

### 11.1 ABSOLUTE MAXIMUM RATINGS

Parameter	Symbol	Value	Unit
Voltage on any pin relative to Vss	V <sub>IN</sub> , V <sub>OUT</sub>	-0.5 ~ V <sub>DDQ</sub> + 0.5V	V
Voltage on VDD supply relative to Vss	V <sub>DD</sub>	-0.5 ~ 2.5	V
Voltage on VDDQ supply relative to Vss	V <sub>DDQ</sub>	-0.5 ~ 2.5	V
MAX Junction Temperature	T <sub>J</sub>	+125	°C
Storage temperature	T <sub>STG</sub>	-55 ~ +150	°C
Power dissipation	P <sub>D</sub>	4	W
Short Circuit Output Current	I <sub>OS</sub>	50	mA

Note :

Stresses greater than those listed under "Absolute Maximum Ratings" may cause permanent damage to the device. This is a stress rating only, and functional operation of the device at these or any other conditions above those indicated in the operational sections of this specification is not implied. Exposure periods may affect reliability.

### 11.2 POWER & DC OPERATING CONDITIONS

Recommended operating conditions (0°C ≤ T<sub>c</sub> ≤ 85°C ; VDD/VDDQ=1.8V ± 0.1V for -BC\*\*, VDD/VDDQ=1.9V ± 0.1V for -BJ\*\*)

Parameter	Symbol	Min	Typ	Max	Unit	Note
Device Supply voltage	V <sub>DD</sub>	1.7	1.8	1.9	V	1,6
Output Supply voltage	V <sub>DDQ</sub>	1.7	1.8	1.9	V	1,6
Device Supply voltage	V <sub>DD</sub>	1.8	1.9	2.0	V	1,7
Output Supply voltage	V <sub>DDQ</sub>	1.8	1.9	2.0	V	1,7
Reference voltage	V <sub>REF</sub>	0.69*V <sub>DDQ</sub>	-	0.71*V <sub>DDQ</sub>	V	2
DC Input logic high voltage	V <sub>IH</sub> (DC)	V <sub>REF</sub> +0.15	-	-	V	3
DC Input logic low voltage	V <sub>IL</sub> (DC)	-	-	V <sub>REF</sub> -0.15	V	3
Output logic low voltage	V <sub>OL</sub> (DC)	-	-	0.76	V	8
AC Input logic high voltage	V <sub>IH</sub> (AC)	V <sub>REF</sub> +0.25	-	-	V	3,4,5
AC Input logic low voltage	V <sub>IL</sub> (AC)	-	-	V <sub>REF</sub> -0.25	V	3,4,5
Input leakage current Any input 0V-<V <sub>IN</sub> -< V <sub>DDQ</sub> (All other pins not under test = 0V)	I <sub>I</sub>	-5	-	5	uA	
Output leakage current (DQs are disabled ; 0V-<V <sub>OUT</sub> -< V <sub>DDQ</sub> )	I <sub>IOZ</sub>	-5	-	5	uA	

Note :

- Under all conditions, V<sub>DDQ</sub> must be less than or equal to V<sub>DD</sub>.
- V<sub>REF</sub> is expected to equal 70% of V<sub>DDQ</sub> for the transmitting device and to track variations in the DC level of the same. Peak-to-peak noise on V<sub>REF</sub> may not exceed ± 2 percent of the DC value. Thus, from 70% of V<sub>DDQ</sub>, V<sub>REF</sub> is allowed ± 25mV for DC error and an additional ±25mV for AC noise.
- The DC values define where the input slew rate requirements are imposed, and the input signal must not violate these levels in order to maintain a valid level. The inputs require the AC value to be achieved during signal transition edge and the driver should achieve the same slew rate through the AC values.
- Input and output slew rate =3V/ns. If the input slew rate is less than 3V/ns, input timing may be compromised. All slew rate are measured between V<sub>IH</sub> and V<sub>IL</sub>. DQ and DM input slew rate must not deviate from DQS by more than 10%. If the DQ,DM and DQS slew rate is less than 3V/ns, timing is longer than referenced to the mid-point but to the V<sub>IL</sub>(AC) maximum and V<sub>IH</sub>(AC) minimum points.
- V<sub>IH</sub> overshoot : V<sub>IH</sub>(max) = V<sub>DDQ</sub> + 0.5V for a pulse width ≤ 500ps and the pulse width can not be greater than 1/3 of the cycle rate.  
V<sub>IL</sub> undershoot : V<sub>IL</sub>(min)=0.0V for a pulse width ≤ 500ps and the pulse width can not be greater than 1/3 of the cycle rate.
- K4J55323QI-BC\*\*
- K4J55323QI-BJ\*\*
- V<sub>OL</sub>(DC) max for -BJ\*\* is 0.84V

11.3 CLOCK INPUT OPERATING CONDITIONS

Recommended operating conditions ( $0^{\circ}\text{C} \leq T_c \leq 85^{\circ}\text{C}$  ;  $V_{DD}/V_{DDQ}=1.8\text{V} \pm 0.1\text{V}$  for -BC\*\*,  $V_{DD}/V_{DDQ}=1.9\text{V} \pm 0.1\text{V}$  for -BJ\*\*)

Parameter/ Condition	Symbol	Min	Max	Unit	Note
Clock Input Mid-Point Voltage ; CK and /CK	VMP(DC)	$V_{DDQ} * 0.7 - 0.1\text{V}$	$V_{DDQ} * 0.7 + 0.1\text{V}$	V	1,2,3,7
Clock Input Voltage Level; CK and /CK	VIN(DC)	0.42	$V_{DDQ} + 0.3$	V	2,7
Clock Input Differential Voltage ; CK and /CK	VID(DC)	0.22	$V_{DDQ} + 0.5$	V	2,4,7
Clock Input Differential Voltage ; CK and /CK	VID(AC)	0.22	$V_{DDQ} + 0.3$	V	4,7
Clock Input Crossing Point Voltage ; CK and /CK	VIX(AC)	$V_{REF} - 0.15$	$V_{REF} + 0.15$	V	3,7

Note :

1. This provides a minimum of 1.16V to a maximum of 1.36V for -BC part and 1.3V ~ 1.5V for -BJ part and is always 70% of VDDQ
2. For AC operations, all DC clock requirements must be satisfied as well.
3. The value of VIX is expected to equal 70% VDDQ for the transmitting device and must track variations in the DC level of the same.
4. VID is the magnitude of the difference between the input level in CK and the input level on /CK.
5. The CK and /CK input reference level (for timing referenced to CK and /CK) is the point at which CK and /CK cross; the input reference level for signals other than CK and /CK is VREF.
6. CK and /CK input slew rate must be  $\geq 3\text{V/ns}$
7.  $V_{DD} \& V_{DDQ} = 1.8\text{V} \pm 0.1\text{V}$  for -BC\*\* and  $V_{DD} \& V_{DDQ} = 1.9\text{V} \pm 0.1\text{V}$  for -BJ\*\*

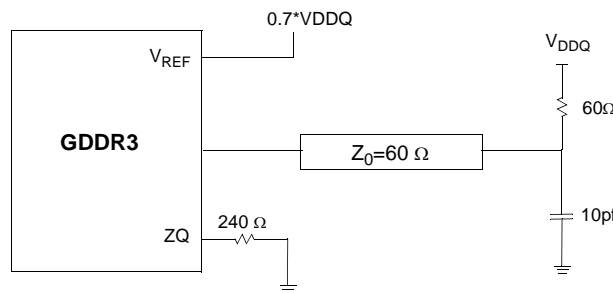

Output Load Circuit

Note : 1 . Outputs measured into equivalent load of 10pf at a driver impedance of 40 Ω.

**11.4 DC CHARACTERISTICS** ( $0^{\circ}\text{C} \leq T_c \leq 85^{\circ}\text{C}$  ;  $V_{DD}/V_{DDQ}=1.8\text{V} \pm 0.1\text{V}$  for -BC\*\*,  $V_{DD}/V_{DDQ}=1.9\text{V} \pm 0.1\text{V}$  for -BJ\*\*)

Parameter	Symbol	Test Condition	Version				Unit	Note
			-BJ1A	-BJ11	-BC12	-BC14		
Operating Current (One Bank Active)	ICC1	Burst Length=4 $t_{RC} \geq t_{RC}(\text{min})$ $I_{OL}=0\text{mA}$ , $t_{CC}=t_{CC}(\text{min})$	475	440	400	380	mA	1
Precharge Standby Current in Power-down mode	ICC2P	$\text{CKE} \leq V_{IL}(\text{max})$ , $t_{CC}=t_{CC}(\text{min})$	95	90	85	85	mA	1,3
Precharge Standby Current in Non Power-down mode	ICC2N	$\text{CKE} \geq V_{IH}(\text{min})$ , $\text{CS} \geq V_{IH}(\text{min})$ , $t_{CC}=t_{CC}(\text{min})$	165	155	145	145	mA	1,3
Active Standby Current power-down mode	ICC3P	$\text{CKE} \leq V_{IL}(\text{max})$ , $t_{CC}=t_{CC}(\text{min})$	120	115	105	100	mA	1,3
Active Standby Current in in Non Power-down mode	ICC3N	$\text{CKE} \geq V_{IH}(\text{min})$ , $\text{CS} \geq V_{IH}(\text{min})$ , $t_{CC}=t_{CC}(\text{min})$	340	320	295	290	mA	1,3
Operating Current (Burst Mode)	ICC4	$I_{OL}=0\text{mA}$ , $t_{CC}=t_{CC}(\text{min})$ , Page Burst, All Banks activated.	735	680	620	590	mA	1
Refresh Current	ICC5	$t_{RC} \geq t_{RFC}$	465	430	385	365	mA	1,2
Self Refresh Current	ICC6	$\text{CKE} \leq 0.2\text{V}$	20	20	20	20	mA	1
Operating Current (4Bank interleaving)	ICC7	Burst Length=4 $t_{RC} \geq t_{RC}(\text{min})$ $I_{OL}=0\text{mA}$ , $t_{CC}=t_{CC}(\text{min})$	1145	1065	970	925	mA	1

Note :

1. Measured with outputs open and ODT off
2. Refresh period is 32ms
3.  $V_{IH}(\text{AC})$  and  $V_{IL}(\text{AC})$

**11.5 CAPACITANCE**

(VDD=1.8V, TA= 25°C, f=1MHz)

Parameter	Symbol	Min	Max	Unit
Input capacitance (CK, $\overline{\text{CK}}$ )	CIN1	1.5	3.0	pF
Input capacitance (A0~A11, BA0~BA1)	CIN2	1.5	3.0	pF
Input capacitance (CKE, $\overline{\text{CS}}$ , $\overline{\text{RAS}}$ , $\overline{\text{CAS}}$ , $\overline{\text{WE}}$ )	CIN3	1.5	3.0	pF
Data & DQS input/output capacitance(DQ0~DQ31)	COUT	1.5	2.0	pF
Input capacitance(DM0 ~ DM3)	CIN4	1.5	2.0	pF

## 11.6 AC CHARACTERISTICS (I-I)

Parameter	Symbol	-BJ1A		-BJ11		Unit	Note
		Min	Max	Min	Max		
DQS out access time from CK	$t_{DQSCK}$	-0.20	+0.20	-0.22	+0.22	ns	
CK high-level width	$t_{CH}$	0.45	0.55	0.45	0.55	tCK	
CK low-level width	$t_{CL}$	0.45	0.55	0.45	0.55	tCK	
CK cycle time	CL=12	1.0	3.3	-	3.3	ns	
	CL=11	1.1/1.25		1.1			
	CL=10	1.4		1.4			
WRITE Latency	$t_{WL}$	1,2,3,7	-	1,2,3,7	-	tCK	1
DQ and DM input hold time relative to DQS	$t_{DH}$	0.13	-	0.15	-	ns	
DQ and DM input setup time relative to DQS	$t_{DS}$	0.13	-	0.15	-	ns	
Active termination setup time	$t_{ATS}$	10	-	10	-	ns	
Active termination hold time	$t_{ATH}$	10	-	10	-	ns	
DQS input high pulse width	$t_{DQSH}$	0.48	0.52	0.48	0.52	tCK	
DQS input low pulse width	$t_{DQSL}$	0.48	0.52	0.48	0.52	tCK	
Data strobe edge to Dout edge	$t_{DQSQ}$	-0.130	0.130	-0.130	0.130	ns	
DQS read preamble	$t_{RPRE}$	0.4	0.6	0.4	0.6	tCK	
DQS read postamble	$t_{RPST}$	0.4	0.6	0.4	0.6	tCK	
Write command to first DQS latching transition	$t_{DQSS}$	WL-0.2	WL+0.2	WL-0.2	WL+0.2	tCK	
DQS write preamble	$t_{WPRE}$	0.4	0.6	0.4	0.6	tCK	2
DQS write preamble setup time	$t_{WPRES}$	0	-	0	-	ns	
DQS write postamble	$t_{WPST}$	0.4	0.6	0.4	0.6	tCK	3
Half strobe period	$t_{HP}$	$t_{CLmin}$ or $t_{CHmin}$	-	$t_{CLmin}$ or $t_{CHmin}$	-	tCK	
Data output hold time from DQS	$t_{QH}$	$t_{HP}-0.12$	-	$t_{HP}-0.13$	-	ns	
Data-out high-impedance window from CK and /CK	$t_{HZ}$	-0.3	-	-0.3	-	ns	4
Data-out low-impedance window from CK and /CK	$t_{LZ}$	-0.3	-	-0.3	-	ns	4
Address and control input hold time	$t_{IH}$	0.27	-	0.27	-	ns	
Address and control input setup time	$t_{IS}$	0.27	-	0.27	-	ns	
Address and control input pulse width	$t_{IPW}$	0.8	-	0.8	-	ns	
Jitter over 1~6 clock cycle error	$t_J$	-	0.03	-	0.03	tCK	5
Cycle to cycle duty cycle error	$t_{DCERR}$	-	0.03	-	0.03	tCK	
Rise and fall times of CK	$t_R, t_F$	-	0.2	-	0.2	tCK	

Note : 1. The WRITE latency can be set from 1 to 7 clocks. When the WRITE latency is set to 1 or 2 or 3 clocks, the input buffers are turned on during the ACTIVE commands reducing the latency but added power. When the WRITE latency is set to 4 ~7 clocks which must be greater than 7ns, the input buffers are turned on during the WRITE commands for lower power operation.

2. A low to high transition on the WDQS line is not allowed in the half clock prior to the write preamble.

3. The last rising edge of WDQS after the write postamble must be driven high by the controller. WDQS can not be pulled high by the on-die termination alone.

4. tHZ and tLZ transitions occur in the same access time windows as valid data transitions. These parameters are not referenced to a specific voltage level, but specify when the device output is no longer driving (HZ) or begins driving (LZ).

5. The cycle to cycle jitter over 1~6 cycle short term jitter

## AC CHARACTERISTICS (I-II)

Parameter	Symbol	-BC12		-BC14		Unit	Note
		Min	Max	Min	Max		
DQS out access time from CK	$t_{DQSCK}$	-0.23	+0.23	-0.26	+0.26	ns	
CK high-level width	$t_{CH}$	0.45	0.55	0.45	0.55	tCK	
CK low-level width	$t_{CL}$	0.45	0.55	0.45	0.55	tCK	
CK cycle time	$t_{CK}$	CL=11	1.25	3.3	-	ns	
		CL=10	1.4		1.4		
WRITE Latency	$t_{WL}$	1,2,3,6,7	-	1,2,3,5,6,7	-	tCK	1
DQ and DM input hold time relative to DQS	$t_{DH}$	0.16	-	0.18	-	ns	
DQ and DM input setup time relative to DQS	$t_{DS}$	0.16	-	0.18	-	ns	
Active termination setup time	$t_{ATS}$	10	-	10	-	ns	
Active termination hold time	$t_{ATH}$	10	-	10	-	ns	
DQS input high pulse width	$t_{DQSH}$	0.48	0.52	0.48	0.52	tCK	
DQS input low pulse width	$t_{DQSL}$	0.48	0.52	0.48	0.52	tCK	
Data strobe edge to Dout edge	$t_{DQSQ}$	-0.140	0.140	-0.160	0.160	ns	
DQS read preamble	$t_{RPRE}$	0.4	0.6	0.4	0.6	tCK	
DQS read postamble	$t_{RPST}$	0.4	0.6	0.4	0.6	tCK	
Write command to first DQS latching transition	$t_{DQSS}$	WL-0.2	WL+0.2	WL-0.2	WL+0.2	tCK	
DQS write preamble	$t_{WPRE}$	0.35	-	0.4	0.6	tCK	2
DQS write preamble setup time	$t_{WPRES}$	0	-	0	-	ns	
DQS write postamble	$t_{WPST}$	0.4	0.6	0.4	0.6	tCK	3
Half strobe period	$t_{HP}$	$t_{CLmin}$ or $t_{CHmin}$	-	$t_{CLmin}$ or $t_{CHmin}$	-	tCK	
Data output hold time from DQS	$t_{QH}$	$t_{HP}-0.14$	-	$t_{HP}-0.16$	-	ns	
Data-out high-impedance window from CK and /CK	$t_{HZ}$	-0.3	-	-0.3	-	ns	4
Data-out low-impedance window from CK and /CK	$t_{LZ}$	-0.3	-	-0.3	-	ns	4
Address and control input hold time	$t_{IH}$	0.3	-	0.35	-	ns	
Address and control input setup time	$t_{IS}$	0.3	-	0.35	-	ns	
Address and control input pulse width	$t_{IPW}$	0.9	-	1.0	-	ns	
Jitter over 1~6 clock cycle error	$t_J$	-	0.03	-	0.03	tCK	5
Cycle to cycle duty cycle error	$t_{DCERR}$	-	0.03	-	0.03	tCK	
Rise and fall times of CK	$t_R, t_F$	-	0.2	-	0.2	tCK	

Note : 1. The WRITE latency can be set from 1 to 7 clocks. When the WRITE latency is set to 1 or 2 or 3 clocks, the input buffers are turned on during the ACTIVE commands reducing the latency but added power. When the WRITE latency is set to 4 ~7 clocks which must be greater than 7ns, the input buffers are turned on during the WRITE commands for lower power operation.

2. A low to high transition on the WDQS line is not allowed in the half clock prior to the write preamble.

3. The last rising edge of WDQS after the write postamble must be driven high by the controller. WDQS can not be pulled high by the on-die termination alone.

4.  $t_{HZ}$  and  $t_{LZ}$  transitions occur in the same access time windows as valid data transitions. These parameters are not referenced to a specific voltage level, but specify when the device output is no longer driving (HZ) or begins driving (LZ).

5. The cycle to cycle jitter over 1~6 cycle short term jitter

## AC CHARACTERISTICS II-I

Parameter	Symbol	-BJ1A		-BJ11		Unit	Note
		Min	Max	Min	Max		
Row active time	t <sub>RAS</sub>	29	100K	25	100K	tCK	
Row cycle time	t <sub>RC</sub>	41	-	35	-	tCK	
Refresh row cycle time	t <sub>RFC</sub>	52	-	45	-	tCK	
RAS to CAS delay for Read	t <sub>RCDR</sub>	14	-	12	-	tCK	
RAS to CAS delay for Write	t <sub>RCDW</sub>	10	-	8	-	tCK	
Row precharge time	t <sub>RP</sub>	12	-	10	-	tCK	
Row active to Row active	t <sub>RRD</sub>	10	-	8	-	tCK	
Last data in to Row precharge (PRE or Auto-PRE)	t <sub>WR</sub>	13	-	11	-	tCK	
Last data in to Read command	t <sub>CDLR</sub>	7	-	6	-	tCK	
Mode register set cycle time	t <sub>MRD</sub>	9	-	7	-	tCK	
Auto precharge write recovery time + Precharge	t <sub>DAL</sub>	25	-	21	-	tCK	
Exit self refresh to Read command	t <sub>XSR</sub>	20000	-	20000	-	tCK	
Exit self refresh to Non-Read command	t <sub>XSNR</sub>	100	-	100	-	tCK	
Power-down exit time	t <sub>PDEX</sub>	8tCK +tIS	-	7tCK+tIS	-	tCK	
Refresh interval time	t <sub>REF</sub>	-	7.8	-	7.8	us	

## AC CHARACTERISTICS II-II

Parameter	Symbol	-BC12		-BC14		Unit	Note
		Min	Max	Min	Max		
Row active time	t <sub>RAS</sub>	25	100K	22	100K	tCK	
Row cycle time	t <sub>RC</sub>	35	-	31	-	tCK	
Refresh row cycle time	t <sub>RFC</sub>	45	-	39	-	tCK	
RAS to CAS delay for Read	t <sub>RCDR</sub>	12	-	10	-	tCK	
RAS to CAS delay for Write	t <sub>RCDW</sub>	8	-	6	-	tCK	
Row precharge time	t <sub>RP</sub>	10	-	9	-	tCK	
Row active to Row active	t <sub>RRD</sub>	8	-	8	-	tCK	
Last data in to Row precharge (PRE or Auto-PRE)	t <sub>WR</sub>	11	-	10	-	tCK	
Last data in to Read command	t <sub>CDLR</sub>	6	-	5	-	tCK	
Mode register set cycle time	t <sub>MRD</sub>	7	-	6	-	tCK	
Auto precharge write recovery time + Precharge	t <sub>DAL</sub>	21	-	19	-	tCK	
Exit self refresh to Read command	t <sub>XSR</sub>	20000	-	20000	-	tCK	
Exit self refresh to Non-Read command	t <sub>XSNR</sub>	100	-	100	-	tCK	
Power-down exit time	t <sub>PDEX</sub>	7tCK+tIS	-	6tCK +tIS	-	tCK	
Refresh interval time	t <sub>REF</sub>	-	7.8	-	7.8	us	

11.7 PACKAGE DIMENSIONS (FBGA)

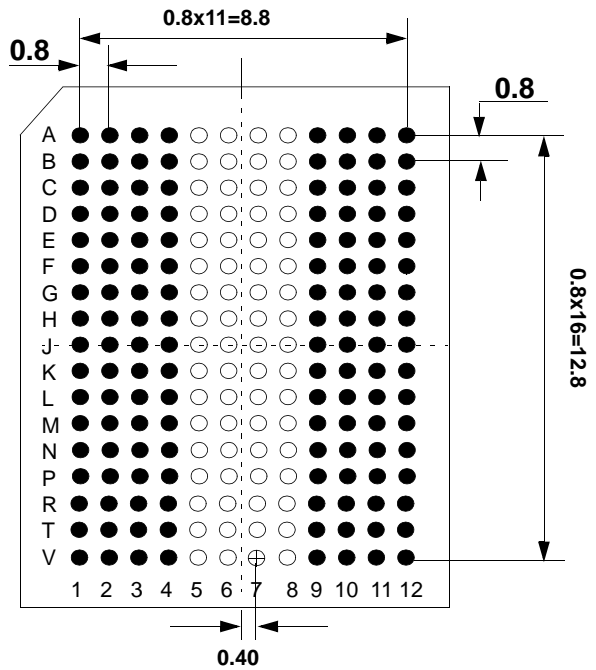
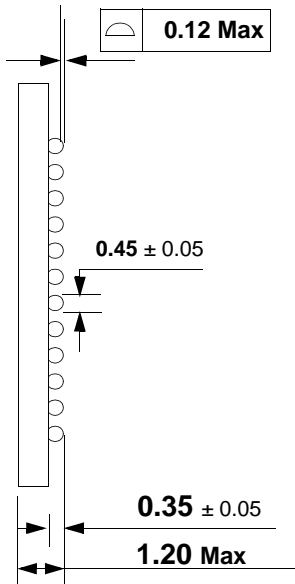
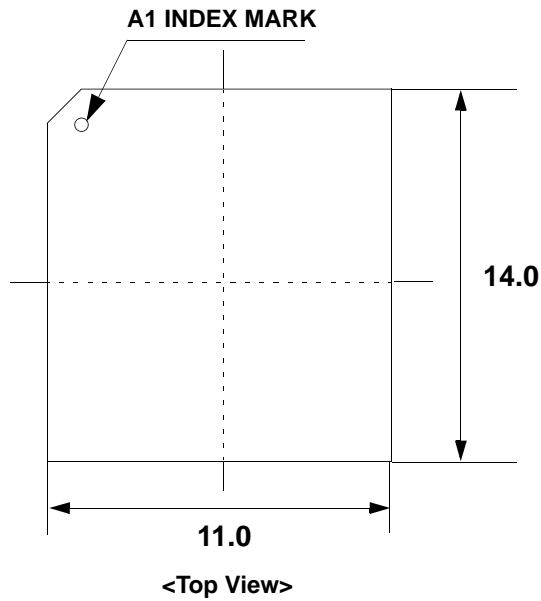

<Top View: See the balls through the package>

- Ball existing
- Depopulated ball