

High-Speed CMOS Logic

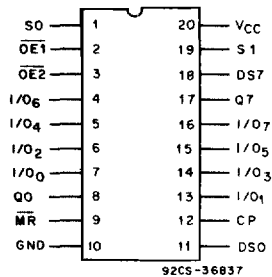

TERMINAL ASSIGNMENT

The RCA-CD54/74HC299 and CD54/74HCT299 are 8-bit shift/storage registers with 3-state bus interface capability. The register has four synchronous-operating modes controlled by the two select inputs as shown in the mode select (S0, S1) table. The mode select, the serial data (DS0, DS7) and the parallel data (I/O₀-I/O₇) respond only to the low-to-high transition of the clock (CP) pulse. S0, S1 and data inputs must be one set-up time prior to the clock positive transition.

The Master Reset (\overline{MR}) is an asynchronous active low input. When MR output is low, the register is cleared regardless of the status of all other inputs. The register can be expanded by cascading same units by tying the serial output (Q0) to the serial data (DS7) input of the preceding register, and tying the serial output (Q7) to the serial data (DS0) input of the following register. Recirculating the (n x 8) bits is accomplished by tying the Q7 of the last stage to the DS0 of the first stage.

The 3-state input/output (I/O) port has three modes of operation:

1. Both output enable ($\overline{OE1}$ and $\overline{OE2}$) inputs are low and S0 or S1 or both are low, the data in the register is presented at the eight outputs.
2. When both S0 and S1 are high, I/O terminals are in the high impedance state but being input ports, ready for parallel data to be loaded into eight registers with one clock transition regardless of the status of $\overline{OE1}$ and $\overline{OE2}$.
3. Either one of the two output enable inputs being high will force I/O terminals to be in the off-state. It is noted that each I/O terminal is a 3-state output and an CMOS buffer input.

The CD54HC299 and CD54HCT299 are supplied in 20-lead hermetic dual-in-line ceramic packages (F suffix). The CD74HC299 and CD74HCT299 are supplied in 20-lead dual-in-line plastic packages (E suffix) and in 20-lead dual-in-line surface mount plastic packages (M suffix). Both types are also available in chip form (H suffix).

8-Bit Universal Shift Register; 3-State

Type Features:

- Four Operation Modes: Shift Left, Shift Right, Load and Store
- Can be cascaded for N-bit word lengths
- I/O₀-I/O₇ bus drive capability and 3-state for bus oriented applications
- Buffered inputs
- Typical $f_{MAX}=50$ MHz @ $V_{CC}=5$ V, $C_L=15$ pF, $T_A=25^\circ$ C

Family Features:

- Fanout (Over Temperature Range):
Standard Outputs - 10 LSTTL Loads
Bus Driver Outputs - 15 LSTTL Loads
- Wide Operating Temperature Range:
CD74HC/HCT: -40 to +85°C
- Balanced Propagation Delay and Transition Times
- Significant Power Reduction Compared to LSTTL Logic ICs
- Alternate Source is Philips/Signetics
- CD54HC/CD74HC Types:
2 to 6 V Operation
High Noise Immunity:
 $N_{IL}=30\%$, $N_{IH}=30\%$ of V_{CC} @ $V_{CC}=5$ V
- CD54HCT/CD74HCT Types:
4.5 to 5.5 V Operation
Direct LSTTL Input Logic Compatibility
 $V_{IL}=0.8$ V Max., $V_{IH}=2$ V Min.
CMOS Input Compatibility
 $I_i \leq 1 \mu$ A @ V_{OL} , V_{OH}

CD54/74HC299

CD54/74HCT299

MAXIMUM RATINGS, Absolute-Maximum Values:

DC SUPPLY-VOLTAGE, (V_{CC}):
 (Voltages referenced to ground) -0.5 to + 7 V

DC INPUT DIODE CURRENT, I_{IK} (FOR $V_i < -0.5$ V OR $V_i > V_{CC} + 0.5$ V) ± 20 mA

DC OUTPUT DIODE CURRENT, I_{OK} (FOR $V_o < -0.5$ V OR $V_o > V_{CC} + 0.5$ V) ± 20 mA

DC DRAIN CURRENT, PER OUTPUT (I_o) (FOR -0.5 V $< V_o < V_{CC} + 0.5$ V)
 For Q Outputs ± 25 mA
 For I/O Outputs ± 35 mA

DC V_{CC} OR GROUND CURRENT (I_{CC}) ± 70 mA

POWER DISSIPATION PER PACKAGE (P_o):
 For $T_A = -40$ to $+60^\circ$ C (PACKAGE TYPE E) 500 mW
 For $T_A = +60$ to $+85^\circ$ C (PACKAGE TYPE E) Derate Linearly at 8 mW/ $^\circ$ C to 300 mW
 For $T_A = -55$ to $+100^\circ$ C (PACKAGE TYPE F, H) 500 mW
 For $T_A = +40$ to $+125^\circ$ C (PACKAGE TYPE F, H) Derate Linearly at 8 mW/ $^\circ$ C to 300 mW
 For $T_A = -40$ to $+70^\circ$ C (PACKAGE TYPE M) 400 mW
 For $T_A = +70$ to $+125^\circ$ C (PACKAGE TYPE M) Derate Linearly at 6 mW/ $^\circ$ C to 70 mW

OPERATING TEMPERATURE RANGE (T_{op})
 PACKAGE TYPE F, H -55 to $+125^\circ$ C
 PACKAGE TYPE E, M -40 to $+85^\circ$ C

STORAGE TEMPERATURE (T_{stg}) -65 to $+150^\circ$ C

LEAD TEMPERATURE (DURING SOLDERING):
 At distance $1/16 \pm 1/32$ in. (1.59 ± 0.79 mm) from case for 10 s max. $+265^\circ$ C
 Unit inserted into a PC Board (min. thickness $1/16$ in., 1.59 mm)
 with solder contacting lead tips only $+300^\circ$ C

RECOMMENDED OPERATING CONDITIONS

For maximum reliability, nominal operating conditions should be selected so that operation is always within the following ranges:

CHARACTERISTIC	LIMITS		UNITS
	MIN.	MAX.	
Supply-Voltage Range (For T_A =Full Package Temperature Range) V_{CC} .*			
CD54/74HC Types	2	6	V
CD54/74HCT Types	4.5	5.5	
DC Input or Output Voltage, V_i, V_o	0	V_{CC}	V
Operating Temperature, T_A :			$^\circ$ C
CD74 Types	-40	+85	
CD54 Types	-55	+125	
Input Rise and Fall Times, t_r, t_f :			ns
at 2 V	0	1000	
at 4.5 V	0	500	
at 6 V	0	400	

*Unless otherwise specified, all voltages are referenced to Ground.

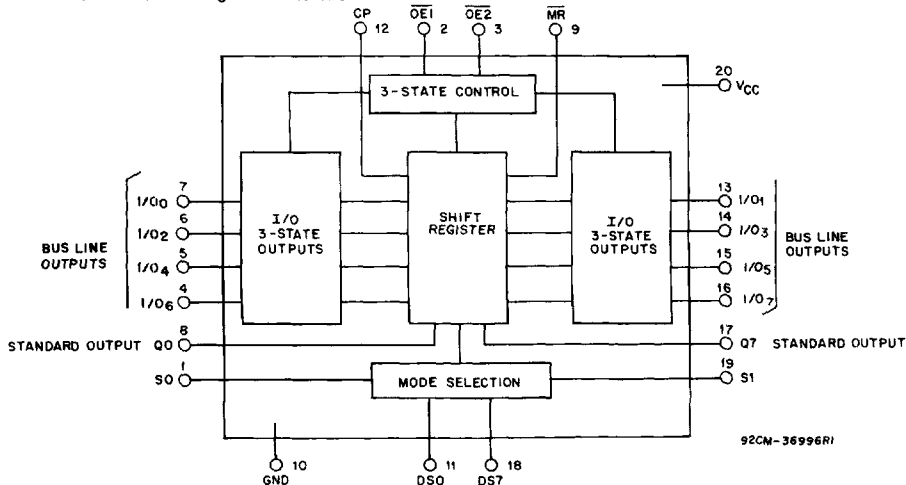

92CM-36996R1

Fig. 1 — Function diagram.

CD54/74HC299 CD54/74HCT299

STATIC ELECTRICAL CHARACTERISTICS

CHARACTERISTIC	CD74HC299/CD54HC299										CD74HCT299/CD54HCT299								UNITS	
	TEST CONDITIONS			74HC/54HC TYPE			74HC TYPE		54HC TYPE		TEST CONDITIONS		74HCT/54HCT TYPE			74HCT TYPE		54HCT TYPE		
	V _I V	I _O mA	V _{CC} V	+25°C			-40/ +85°C		-55/ +125°C		V _I V	V _{CC} V	+25°C			-40/ +85°C		-55/ +125°C		
				Min	Typ	Max	Min	Max	Min	Max			Min	Typ	Max	Min	Max	Min		Max
High-Level Input Voltage V _{IH}			2	1.5	—	—	1.5	—	1.5	—	—	4.5								V
			4.5	3.15	—	—	3.15	—	3.15	—		to	2	—	—	2	—	2	—	
			6	4.2	—	—	4.2	—	4.2	—		5.5								
Low-Level Input Voltage V _{IL}			2	—	—	0.5	—	0.5	—	0.5	—	4.5								V
			4.5	—	—	1.35	—	1.35	—	1.35	—	to	—	—	0.8	—	0.8	—	0.8	—
			6	—	—	1.8	—	1.8	—	1.8	—	5.5								
High-Level Output Voltage V _{OH}	V _{IL} or V _{IH}	-0.02	2	1.9	—	—	1.9	—	1.9	—	V _{IL} or V _{IH}	4.5	4.4	—	—	4.4	—	4.4	—	V
CMOS Loads			4.5	4.4	—	—	4.4	—	4.4	—										
			6	5.9	—	—	5.9	—	5.9	—										
TTL Loads	V _{IL}	Qn I/On									V _{IL} or V _{IH}	4.5	3.98	—	—	3.84	—	3.7	—	V
Bus Driver and Standard Output		-4 -6	4.5	3.98	—	—	3.84	—	3.7	—										
		-5.2 -7.8	6	5.48	—	—	5.34	—	5.2	—										
Low-Level Output Voltage V _{OL}	V _{IL} or V _{IH}	0.02	2	—	—	0.1	—	0.1	—	0.1	V _{IL} or V _{IH}	4.5	—	—	0.1	—	0.1	—	0.1	V
CMOS Loads			4.5	—	—	0.1	—	0.1	—	0.1										
			6	—	—	0.1	—	0.1	—	0.1										
TTL Loads	V _{IL}	Qn I/On									V _{IL} or V _{IH}	4.5	—	—	0.26	—	0.33	—	0.4	V
Bus Driver and Standard Output		4 6	4.5	—	—	0.26	—	0.33	—	0.4										
		5.2 7.8	6	—	—	0.26	—	0.33	—	0.4										
Input Leakage Current I _I	V _{CC} or Gnd		6	—	—	±0.1	—	±1	—	±1	Any Voltage Between V _{CC} and Gnd	5.5	—	—	±0.1	—	±1	—	±1	μA
Quiescent Device Current I _{CC}	V _{CC} or Gnd	0	6	—	—	8	—	80	—	160	V _{CC} or Gnd	5.5	—	—	8	—	80	—	160	μA
Additional Quiescent Device Current per Input Pin: 1 Unit Load ΔI _{CC} *											V _{CC} -2.1	4.5 to 5.5	—	100	360	—	450	—	490	μA
3-State Leakage Current	V _{IL} or V _{IH}	V _O = V _{CC} or Gnd	6	—	—	±0.5	—	±5	—	±10	V _{IL} or V _{IH}	5.5	—	—	±0.5	—	±5	—	±10	μA

*For dual-supply systems theoretical worst case (V_I = 2.4 V, V_{CC} = 5.5 V) specification is 1.8 mA.

HCT Input Loading Table

Input	Unit Loads*
S1, MR	0.25
I/O ₀ -I/O ₇	0.25
DS0, DS7	0.25
S0, CP	0.6
OE1, OE2	0.3

*Unit load is ΔI_{CC} limit specified in Static Characteristics Chart, e.g., 360 μA max. @ 25°C.

CD54/74HC299 CD54/74HCT299

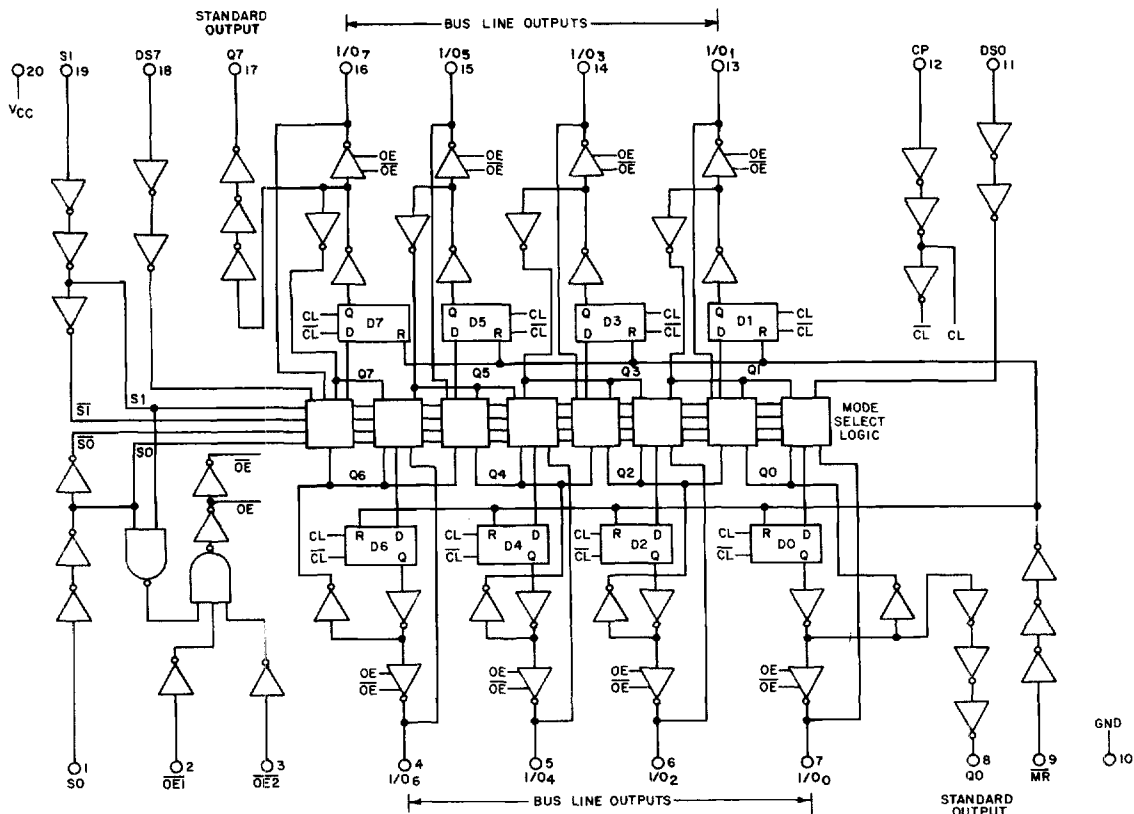

Fig. 2 — Logic diagram.

92CL-37003R2

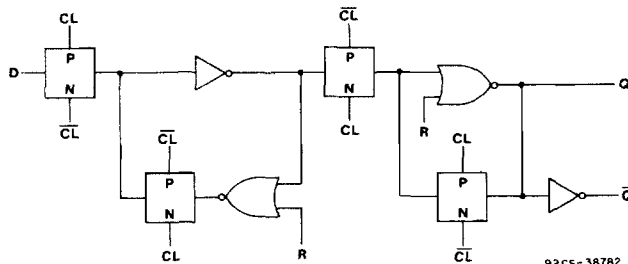

Fig. 3 — Flip-Flop detail (D0-D7).

92CS-38782

MODE SELECT-FUNCTION TABLE

REGISTER OPERATING MODES

FUNCTION	INPUTS							REGISTER OUTPUTS						
	MR	CP	S0	S1	DS0	DS7	I/O _n	Q0	Q1	...	Q6	Q7		
Reset (Clear)	L	X	X	X	X	X	X	L	L	...	L	L		
Shift Right	H		h	l	l	X	X	L	q ₀	...	q ₅	q ₆		
	H		h	l	h	X	X	H	q ₀	...	q ₅	Q ₆		
Shift Left	H		l	h	X	l	X	q ₁	q ₂	...	q ₇	L		
	H		l	h	X	h	X	q ₁	q ₂	...	q ₆	H		
Hold (do nothing)	H		l	l	X	X	X	q ₀	q ₁	...	q ₆	q ₇		
Parallel Load	H		h	h	X	X	l	L	L	...	L	L		
	H		h	h	X	X	h	H	H	...	H	H		

CD54/74HC299
CD54/74HCT299

MODE-SELECT FUNCTION TABLE
3-STATE I/O PORT OPERATING MODE

FUNCTION	INPUTS				Qn(Register)	I/O0 --- I/O7
	OE1	OE2	S0	S1		
Read Register	L	L	L	X	L	L
	L	L	L	X	H	H
	L	L	X	L	L	L
	L	L	X	L	H	H
Load Register	X	X	H	H	Qn = I/On	I/On = Inputs
Disable I/O	H	X	X	X	X	(Z)
	X	H	X	X	X	(Z)

H = Input voltage high level.
 h = Input voltage high one set-up time prior clock transition.
 L = Input voltage low level.
 l = Input voltage low one set-up time prior clock transition.
 q_n = Lower case letter indicates the state of the referenced output one set-up time prior clock transition.

X = Voltage level on logic status don't care.
 Z = Output in high impedance state.
 = Low-to-high clock transition.

SWITCHING CHARACTERISTICS (V_{CC} = 5 V, T_A = 25° C, Input t_r, t_f = 6 ns)

CHARACTERISTIC	SYMBOL	C _L (pF)	TYPICAL VALUES		UNITS
			HC	HCT	
Propagation Delay Clock to I/O Outputs (Fig. 4)	t _{PLH}	15	17	19	ns
	t _{PHL}				
	Clock Q0 or Q7 (Fig. 4)				
MR to Outputs (Fig. 5)	t _{PHL}	15	17	19	ns
Output Enable and Disable Times (Fig. 6 & 7)	t _{PZL} , t _{PZH} t _{PLZ} , t _{PHZ}	15	10,13,15	10,13,15	
Power Dissipation Capacitance	C _{PD} *	—	150	170	pF

*C_{PD} is used to determine the dynamic power consumption, per register.

PD = C_{PD} V_{CC}² fi + Σ (C_L V_{CC}² fo) where:

f_i = input frequency C_L = output load capacitance
 f_o = output frequency V_{CC} = supply voltage

Pre-requisite for Switching Function

CHARACTERISTIC	SYMBOL	V _{CC}	25° C				-40° C to +85° C				-55° C to +125° C				UNITS
			HC		HCT		74HC		74HCT		54HC		54HCT		
			Min.	Max.	Min.	Max.	Min.	Max.	Min.	Max.	Min.	Max.	Min.	Max.	
Maximum Clock Frequency	f _{MAX}	2	6	—	—	5	—	—	—	4	—	—	—	MHz	
		4.5	30	—	25	25	—	20	—	20	—	16	—		
		6	35	—	—	29	—	—	—	23	—	—	—		
MR Pulse Width (Fig. 5)	t _w	2	50	—	—	65	—	—	—	75	—	—	—	ns	
		4.5	10	—	15	13	—	19	—	15	—	22	—		
		6	9	—	—	11	—	—	—	13	—	—	—		
Clock Pulse Width (Fig. 4)	t _w	2	80	—	—	100	—	—	—	120	—	—	—	ns	
		4.5	16	—	20	20	—	25	—	24	—	30	—		
		6	14	—	—	17	—	—	—	20	—	—	—		
Setup Time DS0, DS7, I/On to Clock (Fig. 8)	t _{SU}	2	100	—	—	125	—	—	—	150	—	—	—	ns	
		4.5	20	—	20	25	—	25	—	30	—	30	—		
		6	17	—	—	21	—	—	—	26	—	—	—		
Hold Time DS0, DS7, I/On, S0, S1 to Clock (Fig. 8)	t _H	2	0	—	—	0	—	—	—	0	—	—	—	ns	
		4.5	0	—	0	0	—	0	—	0	—	0	—		
		6	0	—	—	0	—	—	—	0	—	—	—		
Recovery Time MR to Clock (Fig. 5)	t _{REC}	2	5	—	—	5	—	—	—	5	—	—	—	ns	
		4.5	5	—	5	5	—	5	—	5	—	5	—		
		6	5	—	—	5	—	—	—	5	—	—	—		
Setup Time S1, S0 to Clock	t _{SU}	2	120	—	—	150	—	—	—	180	—	—	—	ns	
		4.5	24	—	27	30	—	34	—	36	—	41	—		
		6	20	—	—	26	—	—	—	31	—	—	—		

CD54/74HC299 CD54/74HCT299

SWITCHING CHARACTERISTICS (C_L=50 pF, Input t_r=6 ns)

CHARACTERISTIC	SYMBOL	V _{CC}	25°C				-40°C to +85°C				-55°C to +125°C				UNITS
			HC		HCT		74HC		74HCT		54HC		54HCT		
			Min.	Max.	Min.	Max.	Min.	Max.	Min.	Max.	Min.	Max.	Min.	Max.	
Propagation Delay Clock to I/O Output (Fig. 4)	t _{PLH} t _{PHL}	2	—	200	—	—	—	250	—	—	—	300	—	—	ns
		4.5	—	40	—	45	—	50	—	56	—	60	—	68	
		6	—	34	—	—	—	43	—	—	—	51	—	—	
		2	—	200	—	—	—	250	—	—	—	300	—	—	
		4.5	—	40	—	45	—	50	—	56	—	60	—	68	
		6	—	34	—	—	—	43	—	—	—	51	—	—	
Propagation Delay MR to Output (Fig. 5)	t _{PHL}	2	—	200	—	—	—	250	—	—	—	300	—	—	ns
		4.5	—	40	—	46	—	50	—	58	—	60	—	69	
		6	—	34	—	—	—	43	—	—	—	51	—	—	
Output High-Z to High Level (Fig. 6)	t _{PZH}	2	—	155	—	—	—	195	—	—	—	235	—	—	ns
		4.5	—	31	—	32	—	39	—	40	—	47	—	48	
		6	—	26	—	—	—	33	—	—	—	40	—	—	
Output High Level to High-Z (Fig. 6)	t _{PHZ}	2	—	185	—	—	—	230	—	—	—	280	—	—	ns
		4.5	—	37	—	37	—	46	—	46	—	56	—	56	
		6	—	31	—	—	—	39	—	—	—	48	—	—	
Output Low Level to High-Z (Fig. 7)	t _{PLZ}	2	—	155	—	—	—	195	—	—	—	235	—	—	ns
		4.5	—	31	—	32	—	39	—	40	—	47	—	48	
		6	—	26	—	—	—	33	—	—	—	40	—	—	
Output High-Z to Low Level (Fig. 7)	t _{PZL}	2	—	130	—	—	—	165	—	—	—	195	—	—	ns
		4.5	—	26	—	30	—	33	—	38	—	39	—	45	
		6	—	22	—	—	—	28	—	—	—	33	—	—	
Output Transition Time Q0, Q7 (Fig. 9)	t _{TLH} t _{THL}	2	—	75	—	—	—	95	—	—	—	110	—	—	ns
		4.5	—	15	—	15	—	19	—	19	—	22	—	22	
		6	—	13	—	—	—	16	—	—	—	19	—	—	
		2	—	60	—	—	—	75	—	—	—	90	—	—	
		4.5	—	12	—	12	—	15	—	15	—	18	—	18	
		6	—	10	—	—	—	13	—	—	—	15	—	—	
Input Capacitance	C _i	—	—	10	—	10	—	10	—	10	—	10	—	10	pF
3-State Output Capacitance	C _o	—	—	20	—	20	—	20	—	20	—	20	—	20	

CD54/74HC299 CD54/74HCT299

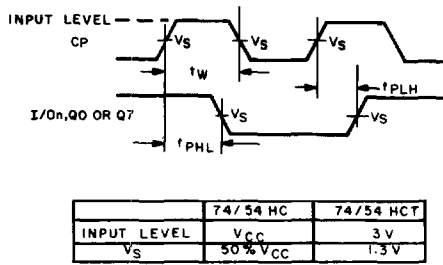

Fig. 4 — Clock pre-requisite and propagation delays.

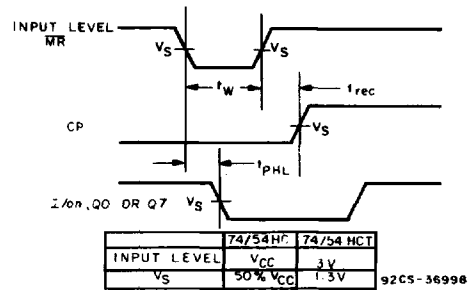

Fig. 5 — Master Reset pre-requisite and propagation delays.

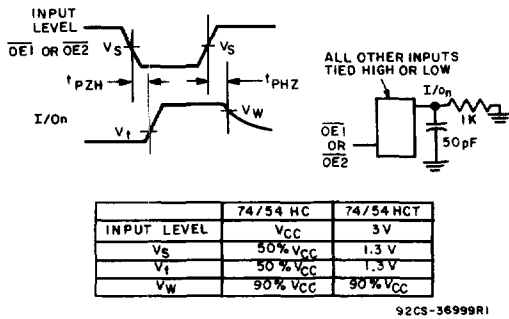

Fig. 6 — 3-state propagation delays.

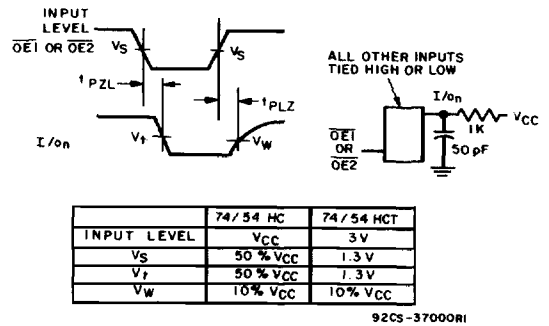

Fig. 7 — 3-state propagation delays.

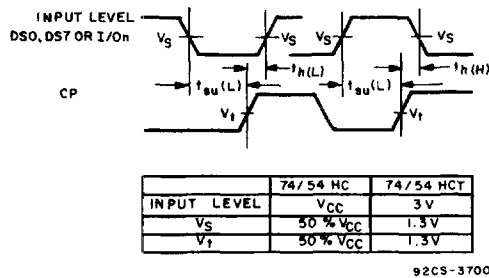

Fig. 8 — Data pre-requisite times.

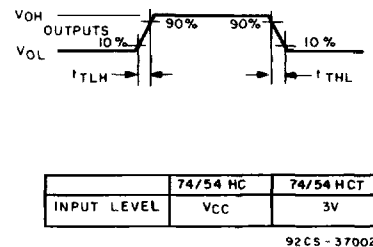

Fig. 9 — Output transition times.