

MCM54402A

Advance Information

4M x 1 CMOS Dynamic RAM
Static Column

The MCM54402A is a 0.7 μ CMOS high-speed dynamic random access memory. It is organized as 1,048,576 four-bit words and fabricated with CMOS silicon-gate process technology. Advanced circuit design and fine line processing provide high performance, improved reliability, and low cost. The static column mode feature allows column data to be accessed upon the column address transition when $\overline{\text{RAS}}$ and $\overline{\text{CS}}$ are held low, similar to static RAM operation.

The MCM54402A requires only 10 address lines; row and column address inputs are multiplexed. The device is packaged in a standard 300 mil J-lead small outline package, a 300 mil thin-small-outline package (TSOP), and a 100 mil zig-zag in-line package (ZIP).

- Three-State Data Output
- Static Column Mode
- Test Mode
- TTL-Compatible Inputs and Outputs
- $\overline{\text{RAS}}$ -Only Refresh
- $\overline{\text{CS}}$ Before RAS Refresh
- Hidden Refresh
- 1024 Cycle Refresh: MCM54402A = 16 ms
- Fast Access Time (t_{RAC}):
 - MCM54402A-60 = 60 ns (Max)
 - MCM54402A-70 = 70 ns (Max)
 - MCM54402A-80 = 80 ns (Max)
- Low Active Power:
 - MCM54402A-60 = 660 mW (Max)
 - MCM54402A-70 = 550 mW (Max)
 - MCM54402A-80 = 468 mW (Max)
- Low Standby Power Dissipation:
 - MCM54402A = 11 mW (Max, TTL Levels)
 - = 5.5 mW (Max, CMOS Levels)

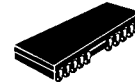

N PACKAGE
300 MIL SOJ
CASE 822-03



T PACKAGE
300 MIL TSOP
CASE 892-01

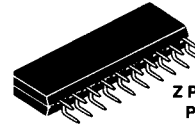

Z PACKAGE
PLASTIC
ZIG-ZAG IN-LINE
CASE 836-02

PIN NAMES

A0 – A9	Address Input
DQ0 – DQ3	Data Input
$\overline{\text{G}}$	Output Enable
$\overline{\text{W}}$	Read/Write Input
RAS	Row Address Strobe
$\overline{\text{CS}}$	Chip Select
VCC	Power Supply (+5 V)
VSS	Ground

PIN ASSIGNMENTS

100 MIL ZIP

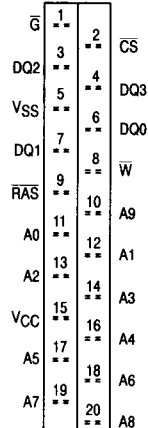

300 MIL SOJ/TSOP

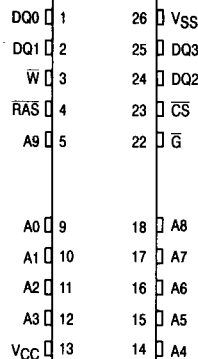

This document contains information on a new product. Specifications and information herein are subject to change without notice.

BLOCK DIAGRAM

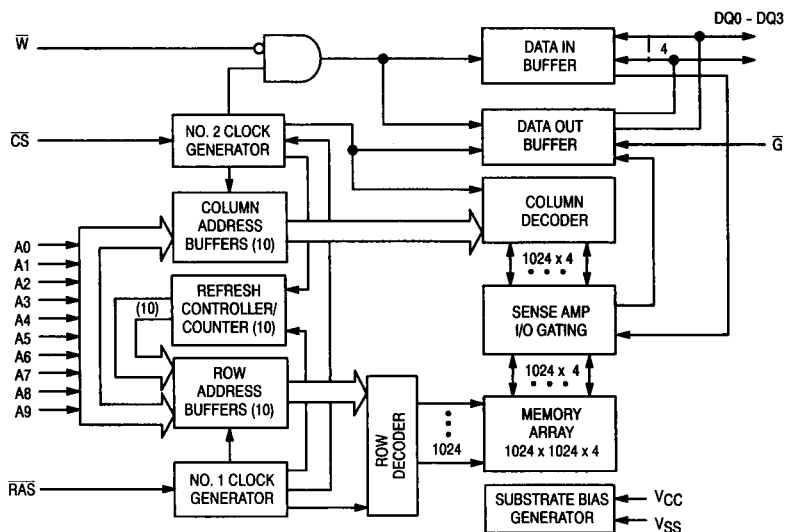

ABSOLUTE MAXIMUM RATINGS (See Note)

Rating	Symbol	Value	Unit
Power Supply Voltage	V_{CC}	- 1 to + 7	V
Voltage Relative to V_{SS} for Any Pin Except V_{CC}	V_{in}, V_{out}	- 1 to + 7	V
Data Out Current	I_{out}	50	mA
Power Dissipation	P_D	700	mW
Operating Temperature Range	T_A	0 to + 70	°C
Storage Temperature Range	T_{stg}	- 55 to + 150	°C

NOTE: Permanent device damage may occur if ABSOLUTE MAXIMUM RATINGS are exceeded. Functional operation should be restricted to RECOMMENDED OPERATING CONDITIONS. Exposure to higher than recommended voltages for extended periods of time could affect device reliability.

This device contains circuitry to protect the inputs against damage due to high static voltages or electric fields; however, it is advised that normal precautions be taken to avoid application of any voltage higher than maximum rated voltages to these high-impedance circuits.

DC OPERATING CONDITIONS AND CHARACTERISTICS

($V_{CC} = 5.0 \text{ V} \pm 10\%$, $T_A = 0 \text{ to } +70^\circ\text{C}$, Unless Otherwise Noted)

RECOMMENDED OPERATING CONDITIONS (All voltages referenced to V_{SS})

Parameter	Symbol	Min	Typ	Max	Unit
Supply Voltage (Operating Voltage Range)	V_{CC}	4.5	5.0	5.5	V
	V_{SS}	0	0	0	
Logic High Voltage, All Inputs	V_{IH}	2.4	—	6.5	V
Logic Low Voltage, All Inputs	V_{IL}	-1.0	—	0.8	V

DC CHARACTERISTICS AND SUPPLY CURRENTS

Characteristic	Symbol	Min	Max	Unit	Notes
V_{CC} Power Supply Current MCM54402A-60, $t_{RC} = 110 \text{ ns}$ MCM54402A-70, $t_{RC} = 130 \text{ ns}$ MCM54402A-80, $t_{RC} = 150 \text{ ns}$	I_{CC1}	—	120 100 85	mA	1, 2
V_{CC} Power Supply Current (Standby) ($\overline{RAS} = \overline{CS} = V_{IH}$)	I_{CC2}	—	2.0	mA	
V_{CC} Power Supply Current During \overline{RAS} -Only Refresh Cycles ($\overline{CS} = V_{IH}$) MCM54402A-60, $t_{RC} = 110 \text{ ns}$ MCM54402A-70, $t_{RC} = 130 \text{ ns}$ MCM54402A-80, $t_{RC} = 150 \text{ ns}$	I_{CC3}	—	120 100 85	mA	1, 2
V_{CC} Power Supply Current During Static Column Mode Cycle ($\overline{RAS} = \overline{CS} = V_{IL}$) MCM54402A-60, $t_{SC} = 35 \text{ ns}$ MCM54402A-70, $t_{SC} = 40 \text{ ns}$ MCM54402A-80, $t_{SC} = 45 \text{ ns}$	I_{CC4}	—	95 85 75	mA	1, 2
V_{CC} Power Supply Current (Standby) ($\overline{RAS} = \overline{CS} = V_{CC} - 0.2 \text{ V}$)	I_{CC5}	—	1.0	mA	
V_{CC} Power Supply Current During \overline{CS} Before \overline{RAS} Refresh Cycle MCM54402A-60, $t_{RC} = 110 \text{ ns}$ MCM54402A-70, $t_{RC} = 130 \text{ ns}$ MCM54402A-80, $t_{RC} = 150 \text{ ns}$	I_{CC6}	—	120 100 85	mA	1
Input Leakage Current ($0 \text{ V} \leq V_{in} \leq 6.5 \text{ V}$)	$I_{kg(I)}$	-10	10	μA	
Output Leakage Current ($\overline{CS} = V_{IH}$, $0 \text{ V} \leq V_{out} \leq 5.5 \text{ V}$)	$I_{kg(O)}$	-10	10	μA	
Output High Voltage ($I_{OH} = -5 \text{ mA}$)	V_{OH}	2.4	—	V	
Output Low Voltage ($I_{OL} = 4.2 \text{ mA}$)	V_{OL}	—	0.4	V	

NOTES:

- Current is a function of cycle rate and output loading; maximum currents are specified cycle time (minimum) with the output open.
- Column address can be changed once or less while $\overline{RAS} = V_{IL}$ and $\overline{CS} = V_{IH}$.

CAPACITANCE ($f = 1.0 \text{ MHz}$, $T_A = 25^\circ\text{C}$, $V_{CC} = 5 \text{ V}$, Periodically Sampled Rather Than 100% Tested)

Characteristic	Symbol	Max	Unit
Input Capacitance	A0 - A9	5	pF
	\overline{G} , \overline{RAS} , \overline{CS} , W	7	
I/O Capacitance ($\overline{CS} = V_{IH}$ to Disable Output)	DQ0 - DQ3	7	pF

NOTE: Capacitance measured with a Boonton Meter or effective capacitance calculated from the equation: $C = I \Delta t / \Delta V$.

AC OPERATING CONDITIONS AND CHARACTERISTICS

($V_{CC} = 5.0\text{ V} \pm 10\%$, $T_A = 0\text{ to }70^\circ\text{C}$, Unless Otherwise Noted)

READ, WRITE, AND READ-WRITE CYCLES (See Notes 1, 2, 3, and 4)

Parameter	Symbol		MCM54402A-60		MCM54402A-70		MCM54402A-80		Unit	Notes
	Std	Alt	Min	Max	Min	Max	Min	Max		
Random Read or Write Cycle Time	t_{RELREL}	t_{RC}	110	—	130	—	150	—	ns	5
Read-Write Cycle Time	t_{RELREL}	t_{RWC}	165	—	185	—	205	—	ns	5
Static Column Mode Cycle Time	t_{AVAV}	t_{SC}	35	—	40	—	45	—	ns	
Static Column Mode Read-Write Cycle Time	t_{AVAV}	t_{SRWC}	90	—	100	—	110	—	ns	
Access Time from RAS	t_{RELQV}	t_{RAC}	—	60	—	70	—	80	ns	6, 7
Access Time from \overline{CS}	t_{CELQV}	t_{CAC}	—	20	—	20	—	20	ns	6, 8
Access Time from Column Address	t_{AVQV}	t_{AA}	—	30	—	35	—	40	ns	6, 9
Access Time from Last Write	t_{WLQV}	t_{ALW}	—	55	—	65	—	75	ns	6, 10
\overline{CS} to Output in Low-Z	t_{CELQX}	t_{CLZ}	0	—	0	—	0	—	ns	6
Output Buffer and Turn-Off Delay	t_{CEHQZ}	t_{OFF}	0	20	0	20	0	20	ns	11
Data Out Hold from Address Change	t_{AXQX}	t_{AOH}	5	—	5	—	5	—	ns	
Data Out Enable from Write	t_{WHQV}	t_{OW}	—	20	—	20	—	20	ns	
Transition Time (Rise and Fall)	t_T	t_T	3	50	3	50	3	50	ns	
RAS Precharge Time	t_{REHREL}	t_{RP}	40	—	50	—	60	—	ns	
RAS Pulse Width	t_{RELREH}	t_{RAS}	60	10 k	70	10 k	80	10 k	ns	
RAS Pulse Width (Static Column Mode)	t_{RELREH}	t_{RASC}	60	200 k	70	200 k	80	200 k	ns	
RAS Hold Time	t_{CELREH}	t_{RSH}	20	—	20	—	20	—	ns	
\overline{CS} Hold Time	t_{RELCEH}	t_{CSH}	60	—	70	—	80	—	ns	
\overline{CS} Pulse Width	t_{CELCEH}	t_{CS}	20	10 k	20	10 k	20	10 k	ns	
\overline{CS} Pulse Width (Static Column Mode)	t_{CELCEH}	t_{CSC}	20	200 k	20	200 k	20	200 k	ns	
RAS to \overline{CS} Delay Time	t_{RELCEL}	t_{RCD}	20	40	20	50	20	60	ns	12
RAS to Column Address Delay Time	t_{RELAV}	t_{RAD}	15	30	15	35	15	40	ns	13
\overline{CS} to RAS Precharge Time	t_{CEHREL}	t_{CRP}	5	—	5	—	5	—	ns	
\overline{CS} Precharge Time	t_{CEHCEL}	t_{CP}	10	—	10	—	10	—	ns	
Row Address Setup Time	t_{AVREL}	t_{ASR}	0	—	0	—	0	—	ns	
Row Address Hold Time	t_{RELAX}	t_{RAH}	10	—	10	—	10	—	ns	

NOTES:

(continued)

- V_{IH} (min) and V_{IL} (max) are reference levels for measuring timing of input signals. Transition times are measured between V_{IH} and V_{IL} .
- An initial pause of 200 μs is required after power-up followed by 8 RAS cycles before proper device operation is guaranteed.
- The transition time specification applies for all input signals. In addition to meeting the transition rate specification, all input signals must transition between V_{IH} and V_{IL} (or between V_{IL} and V_{IH}) in a monotonic manner.
- AC measurements $t_T = 5.0\text{ ns}$.
- The specifications for t_{RC} (min) and t_{RWC} (min) are used only to indicate cycle time at which proper operation over the full temperature range ($0^\circ\text{C} \leq T_A \leq 70^\circ\text{C}$) is ensured.
- Measured with a current load equivalent to 2 TTL ($-200\ \mu\text{A}$, $+4\ \text{mA}$) loads and 100 pF with the data output trip points set at $V_{OH} = 2.0\ \text{V}$ and $V_{OL} = 0.8\ \text{V}$.
- Assumes that $t_{RCD} \leq t_{RCD}(\text{max})$.
- Assumes that $t_{RCD} \geq t_{RCD}(\text{max})$.
- Assumes that $t_{RAD} \geq t_{RAD}(\text{max})$.
- Assumes that $t_{LWAD} \geq t_{LWAD}(\text{max})$.
- t_{OFF} (max) and/or t_{GZ} (max) defines the time at which the output achieves the open circuit condition and is not referenced to output voltage levels.
- Operation within the t_{RCD} (max) limit ensures that t_{RAC} (max) can be met. t_{RCD} (max) is specified as a reference point only; if t_{RCD} is greater than the specified t_{RCD} (max) limit, then access time is controlled exclusively by t_{CAC} .
- Operation within the t_{RAD} (max) limit ensures that t_{RAC} (max) can be met. t_{RAD} (max) is specified as a reference point only; if t_{RAD} is greater than the specified t_{RAD} (max), then access time is controlled exclusively by t_{AA} .

READ, WRITE, AND READ-WRITE CYCLES (Continued)

Parameter	Symbol		MCM54402A-60		MCM54402A-70		MCM54402A-80		Unit	Notes
	Std	Alt	Min	Max	Min	Max	Min	Max		
Column Address Setup Time	t _{AVCEL}	t _{ASC}	0	—	0	—	0	—	ns	
Column Address Hold Time	t _{CELAX}	t _{CAH}	15	—	15	—	15	—	ns	
Column Address Hold Time Referenced to RAS (Read Cycle)	t _{RELAX}	t _{AR}	70	—	80	—	90	—	ns	
Column Address to RAS Lead Time	t _{AVREH}	t _{RAL}	30	—	35	—	40	—	ns	
Column Address Hold Time Reference to RAS High	t _{REHAX}	t _{AH}	5	—	5	—	5	—	ns	14
Last Write to Column Address Delay Time	t _{WLAV}	t _{LWAD}	20	25	20	30	20	35	ns	15
Last Write to Column Address Hold Time	t _{WLAX}	t _{AHLW}	55	—	65	—	75	—	ns	
Read Command Setup Time	t _{WHCEL}	t _{RCS}	0	—	0	—	0	—	ns	
Read Command Hold Time Referenced to CS	t _{CEHWX}	t _{RCH}	0	—	0	—	0	—	ns	16
Read Command Hold Time Referenced to RAS	t _{REHWX}	t _{RRH}	0	—	0	—	0	—	ns	16
Write Command Hold Time Referenced to CS	t _{CELWH}	t _{WCH}	10	—	15	—	15	—	ns	
Write Command Pulse Width	t _{WLWH}	t _{WP}	10	—	15	—	15	—	ns	
Write Command Inactive Time	t _{WHWL}	t _{WI}	10	—	10	—	10	—	ns	
Write Command to RAS Lead Time	t _{WLREH}	t _{RWL}	20	—	20	—	20	—	ns	
Write Command to CS Lead Time	t _{WLCEH}	t _{CWL}	20	—	20	—	20	—	ns	
Data in Setup Time	t _{DVCEL}	t _{DS}	0	—	0	—	0	—	ns	17
Data in Hold Time	t _{CELDX}	t _{DH}	15	—	15	—	15	—	ns	17
Refresh Period	t _{RVRV}	t _{RFSH}	—	16	—	16	—	16	ms	
Write Command Setup Time	t _{WLCEL}	t _{WCS}	0	—	0	—	0	—	ns	18
CS to Write Delay	t _{CELWL}	t _{CWD}	50	—	50	—	50	—	ns	18
RAS to Write Delay	t _{RELWL}	t _{RWD}	90	—	100	—	110	—	ns	18
Column Address to Write Delay Time	t _{AVWL}	t _{AWD}	60	—	65	—	70	—	ns	18
CS Setup Time for CS Before RAS Refresh	t _{RELCEL}	t _{CSR}	5	—	5	—	5	—	ns	
CS Hold Time for CS Before RAS Refresh	t _{RELCEH}	t _{CHR}	15	—	15	—	15	—	ns	
RAS Precharge to CS Active Time	t _{REHCEL}	t _{RPC}	0	—	0	—	0	—	ns	
CS Precharge Time for CS Before RAS Counter Test	t _{CEHCEL}	t _{CPT}	30	—	40	—	40	—	ns	
RAS Hold Time Referenced to G	t _{GLREH}	t _{ROH}	10	—	10	—	10	—	ns	

NOTES:

(continued)

14. t_{AH} must be met for a read cycle.
15. Operation within the t_{LWAD} (max) limit ensures that t_{ALW} can be met. t_{LWAD} (max) is specified as a reference point only; if t_{LWAD} is greater than the specified t_{LWAD} (max) limit, then access time is controlled exclusively by t_{AA}.
16. Either t_{RRH} or t_{RCH} must be satisfied for a read cycle.
17. These parameters are referenced to $\overline{\text{CAS}}$ leading edge in early write cycles and to $\overline{\text{W}}$ leading edge in read-write cycles.
18. t_{WCS}, t_{RWD}, t_{CWD}, t_{AWD}, and t_{CPWD} are not restrictive operating parameters. They are included in the data sheet as electrical characteristics only; if t_{WCS} ≥ t_{WCS} (min), the cycle is an early write cycle and the data out pin will remain open circuit (high impedance) throughout the entire cycle; if t_{CWD} ≥ t_{CWD} (min), t_{RWD} ≥ t_{RWD} (min), t_{AWD} ≥ t_{AWD} (min), and t_{CPWD} ≥ t_{CPWD} (min) (page mode), the cycle is a read write cycle and the data out will contain data read from the selected cell. If neither of these sets of conditions is satisfied, the condition of the data out (at access time) is indeterminate.

READ, WRITE, AND READ-WRITE CYCLES (Continued)

Parameter	Symbol		MCM54402A-60		MCM54402A-70		MCM54402A-80		Unit	Notes
	Std	Alt	Min	Max	Min	Max	Min	Max		
\bar{G} Access Time	t_{GLQV}	t_{GA}	—	20	—	20	—	20	ns	
\bar{G} to Data Delay	t_{GLHDX}	t_{GD}	20	—	20	—	20	—	ns	
Output Buffer Turn-Off Delay Time from \bar{G}	t_{GHQZ}	t_{GZ}	0	20	0	20	0	20	ns	11
\bar{G} Command Hold Time	t_{WLGL}	t_{GH}	20	—	20	—	20	—	ns	
Write Command Setup Time (Test Mode)	t_{WLREL}	t_{WTS}	10	—	10	—	10	—	ns	
Write Command Hold Time (Test Mode)	t_{RELWH}	t_{WTH}	10	—	10	—	10	—	ns	
Write to RAS Precharge Time (CS Before RAS Refresh)	t_{WHREL}	t_{WRP}	10	—	10	—	10	—	ns	
Write to RAS Hold Time (CS Before RAS Refresh)	t_{RELWL}	t_{WRH}	10	—	10	—	10	—	ns	

3

READ CYCLE

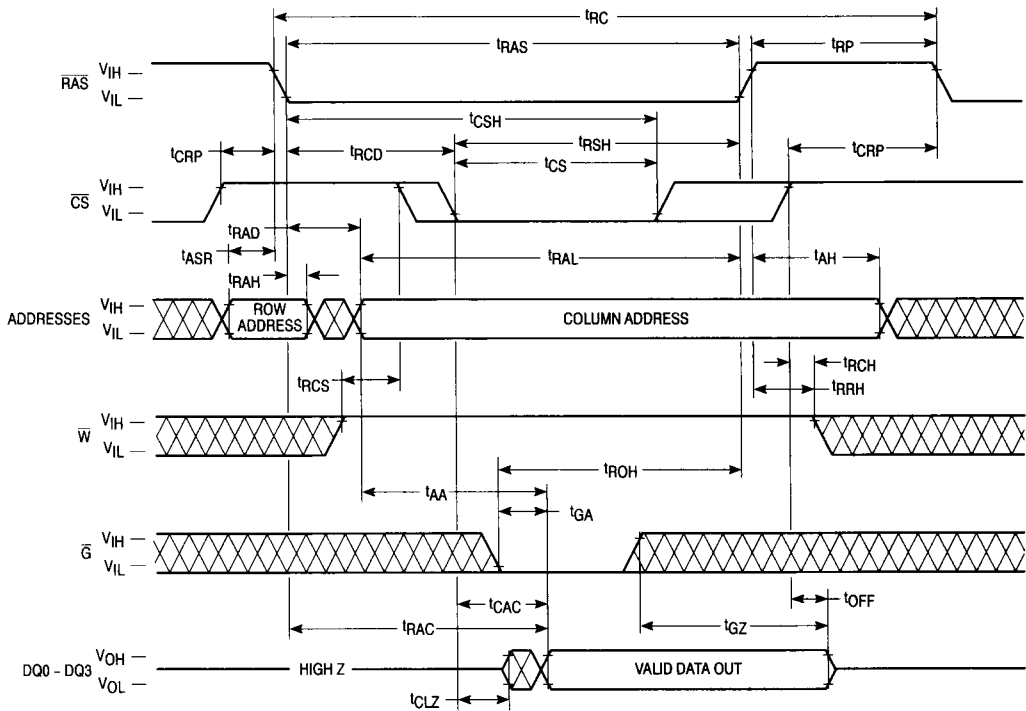

EARLY WRITE CYCLE

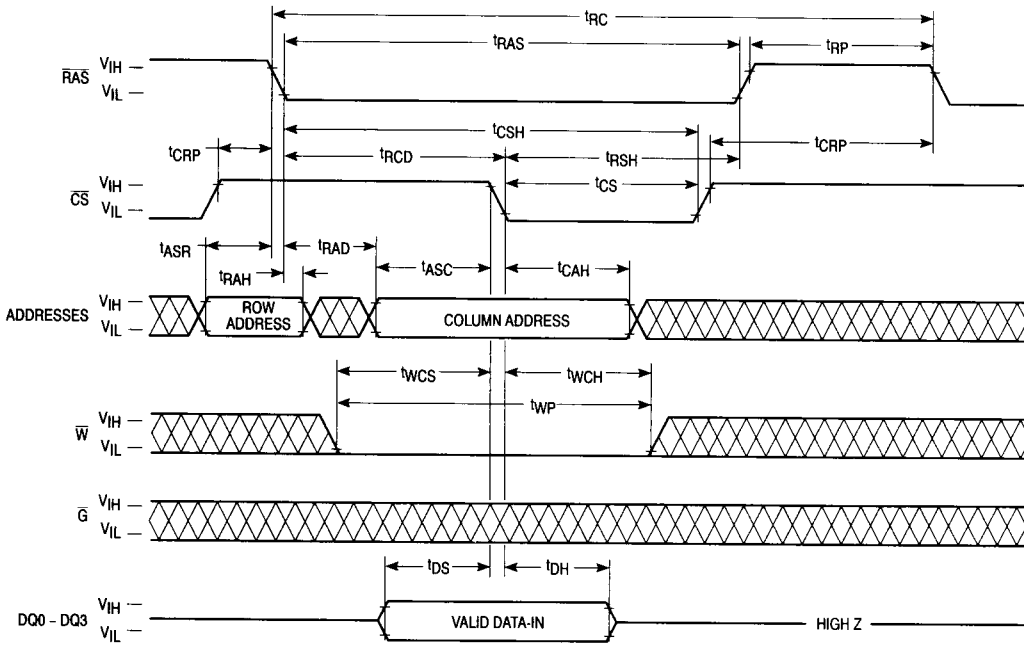

G CONTROLLED LATE WRITE CYCLE

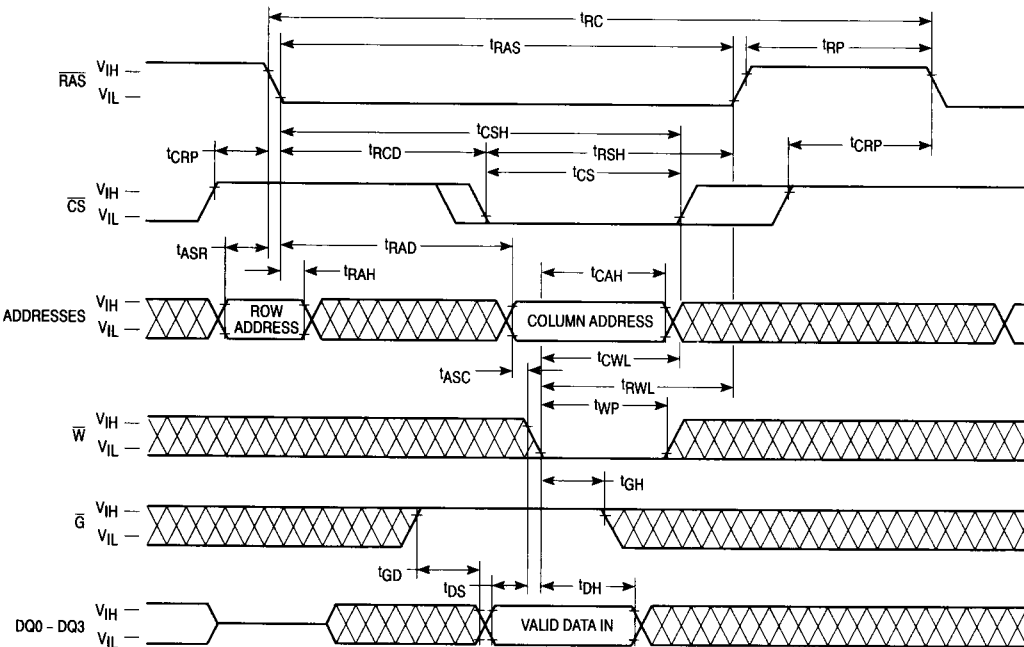

STATIC COLUMN MODE EARLY WRITE CYCLE (A)

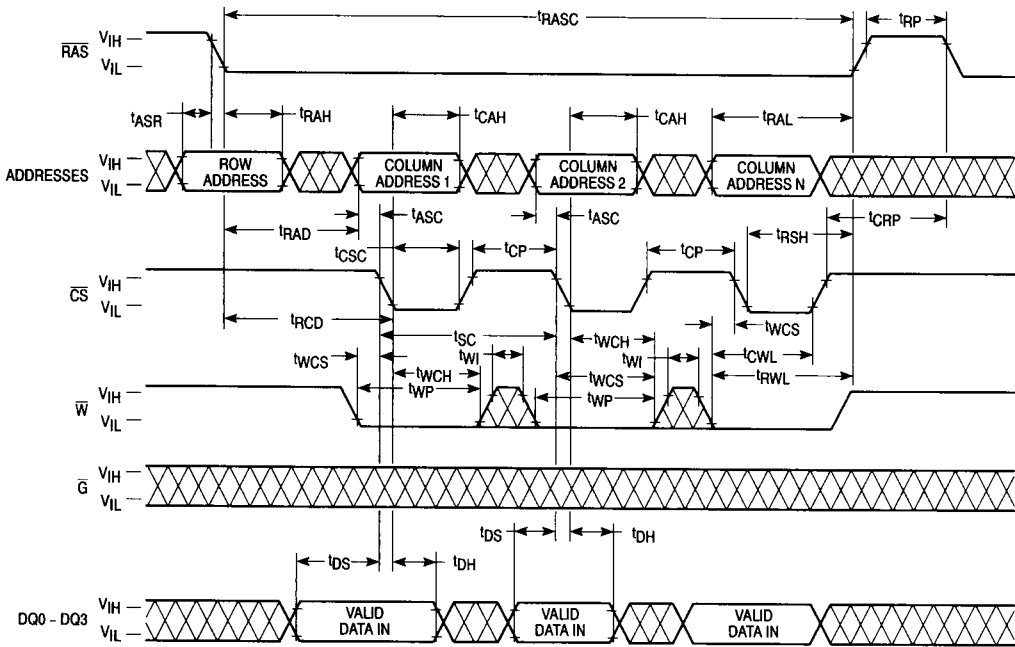

STATIC COLUMN MODE EARLY WRITE CYCLE (B)

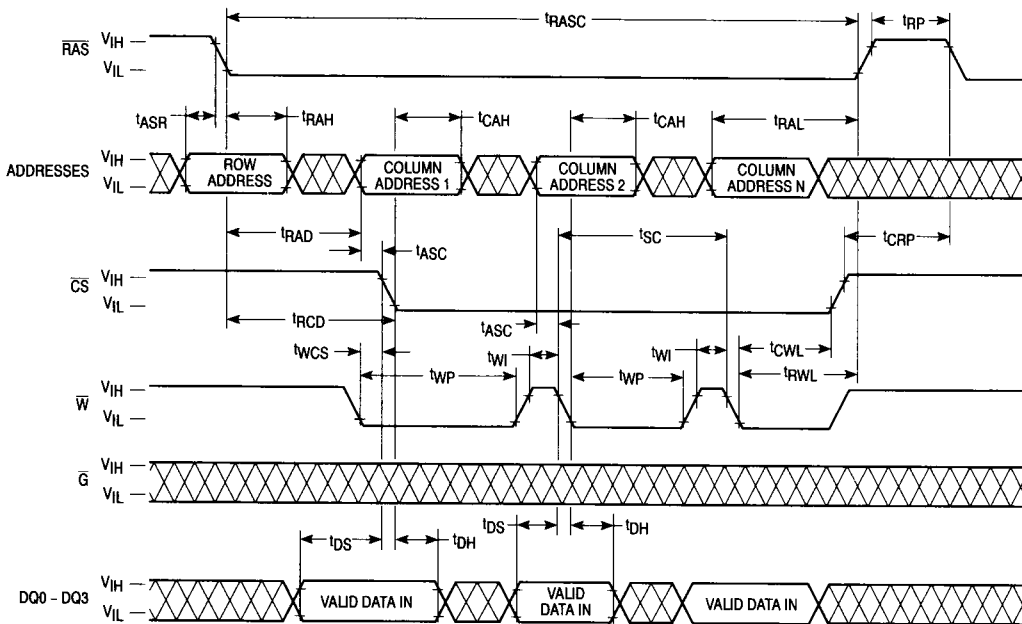

RAS-ONLY REFRESH CYCLE
(\bar{W} and \bar{G} are Don't Care)

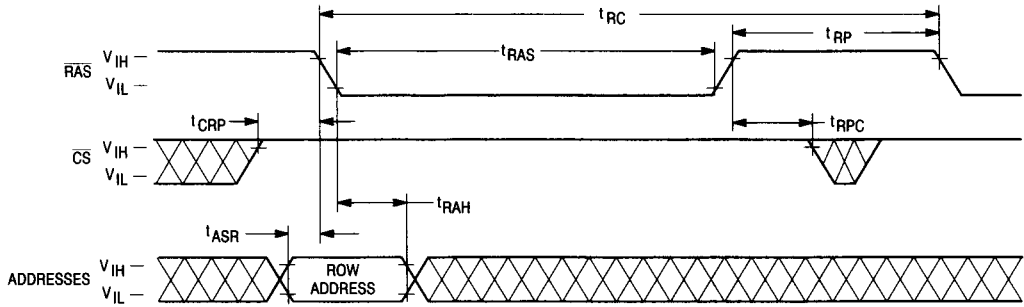

3

\bar{CS} BEFORE \bar{RAS} REFRESH CYCLE
(\bar{G} and $A0 - A9$ are Don't Care)

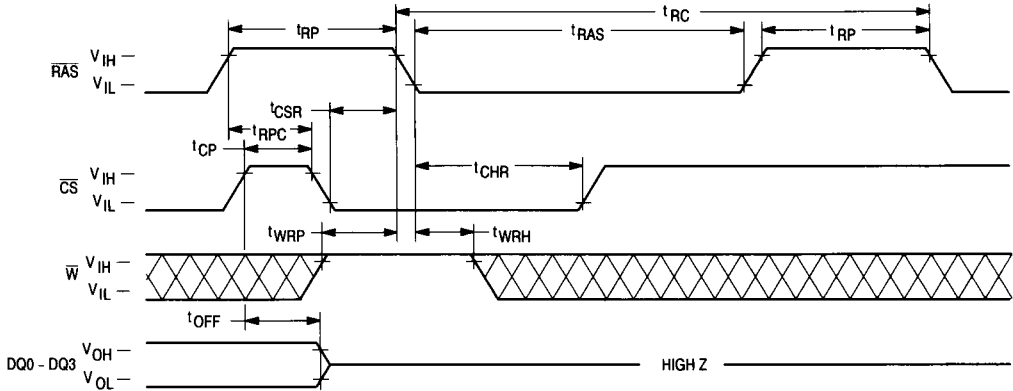

HIDDEN REFRESH CYCLE (READ)

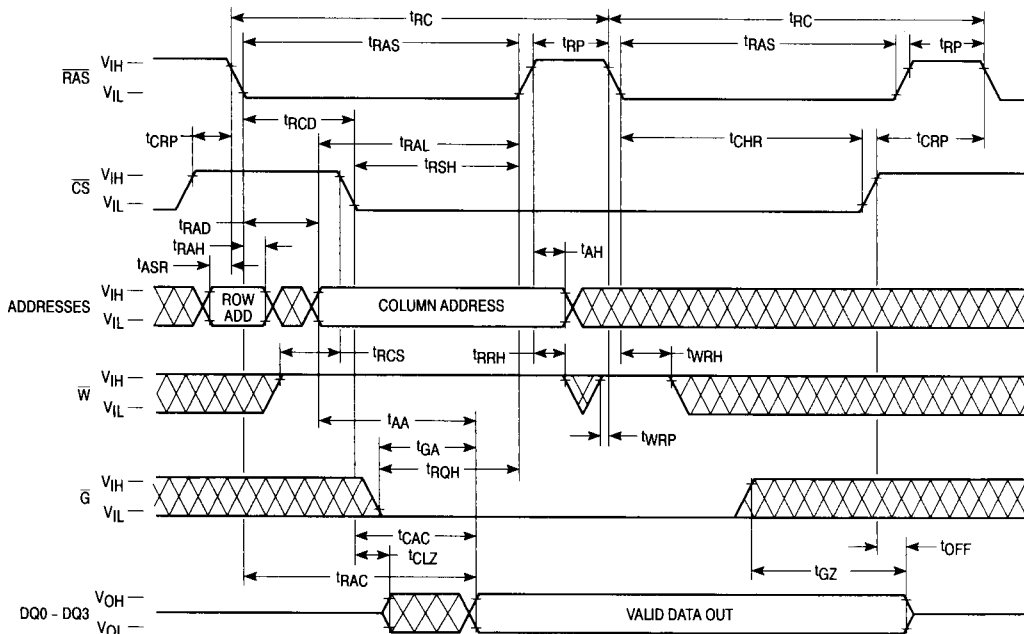

HIDDEN REFRESH CYCLE (EARLY WRITE)

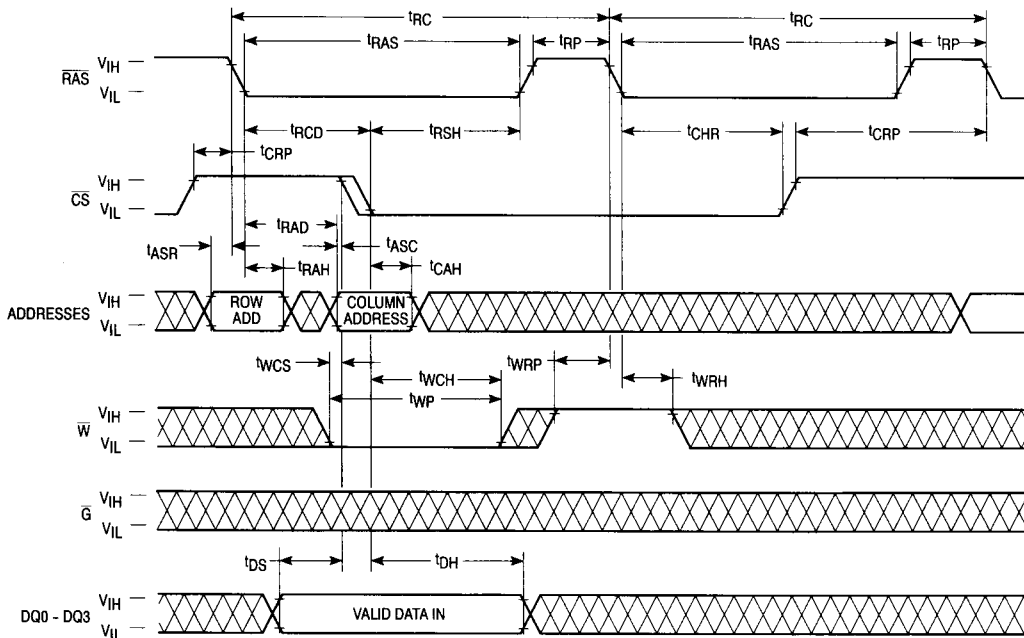

DEVICE INITIALIZATION

On power-up, an initial pause of 200 microseconds is required for the internal substrate generator to establish the correct bias voltage. This must be followed by a minimum of eight active cycles of the row address strobe (clock) to initialize all dynamic nodes within the RAM. During an extended inactive state (greater than 16 milliseconds with the device powered up), a wakeup sequence of eight active cycles is necessary to ensure proper operation.

ADDRESSING THE RAM

The ten address pins on the device are time multiplexed at the beginning of a memory cycle by the row address strobe ($\overline{\text{RAS}}$) clock, into two separate 10-bit address fields. A total of twenty address bits, ten rows and ten columns, will decode one of the 1,048,576 bit locations in the device. $\overline{\text{RAS}}$ active transition latches the row address field. Column addresses are not latched, hence the "static column" designation of this device. Chip select ($\overline{\text{CS}}$) active transition (active = V_{IL} , t_{RCD} minimum) follows $\overline{\text{RAS}}$ on all read, write, or read-write cycles and is independent of column address. The static column feature allows greater flexibility in setting up the external column addresses into the RAM.

There are three other variations in addressing the 1M x 4 RAM: **$\overline{\text{RAS}}$ -only refresh cycle**, **$\overline{\text{CS}}$ before $\overline{\text{RAS}}$ refresh cycle**, and **Static Column mode**. All three are discussed in separate sections that follow.

READ CYCLE

The DRAM may be read with four different cycles: "normal" random read cycle, static column mode read cycle, read-write cycle, and static column mode read-write cycle. The normal read cycle is outlined here, while the other cycles are discussed in separate sections.

The normal read cycle begins as described in **ADDRESSING THE RAM**, with $\overline{\text{RAS}}$ active transition latching the desired row. The write ($\overline{\text{W}}$) input level must be high (V_{IH}), t_{RCS} (minimum) before the $\overline{\text{CS}}$ active transition, to enable read mode. A valid column address can be provided at any time (t_{RAD} minimum), independent of the $\overline{\text{CS}}$ active transition.

Both the $\overline{\text{RAS}}$ and $\overline{\text{CS}}$ clocks trigger a sequence of events that are controlled by several delayed internal clocks. The internal clocks are linked in such a manner that the read access time of the device is independent of the address multiplex window. Both $\overline{\text{CS}}$ and output enable ($\overline{\text{G}}$) control read access time; $\overline{\text{CS}}$ and $\overline{\text{G}}$ must be active (and column address must be valid) by t_{RCD} maximum, and $t_{\text{RAC}} - t_{\text{GA}}$ minimum, respectively, to guarantee valid data out (Q) at t_{RAC} (access time from $\overline{\text{RAS}}$ active transition). If the t_{RCD} maximum is exceeded and/or $\overline{\text{G}}$ active transition does not occur in time, read access time is determined by either the $\overline{\text{CS}}$ or $\overline{\text{G}}$ clock active transition (t_{CAC} or t_{GA}).

The $\overline{\text{RAS}}$ and $\overline{\text{CS}}$ clocks must remain active for minimum times of t_{RAS} and t_{CS} , respectively, to complete the read cycle. The column address must remain valid for t_{AH} after $\overline{\text{RAS}}$ inactive transition to complete the read cycle. $\overline{\text{W}}$ must remain high throughout the cycle, and for time t_{RRH} or t_{RCH} after $\overline{\text{RAS}}$ or $\overline{\text{CS}}$ inactive transition, respectively, to maintain the data at that bit location. Once $\overline{\text{RAS}}$ transitions to inactive, it must remain inactive for a minimum time of t_{RP} to precharge the internal device circuitry for the next active

cycle. Q is valid, but not latched, as long as the $\overline{\text{CS}}$ and $\overline{\text{G}}$ clocks are active. When either the $\overline{\text{CS}}$ or $\overline{\text{G}}$ clock transitions to inactive, the output will switch to High Z (three-state) t_{OFF} or t_{GZ} after the inactive transition.

WRITE CYCLE

The user can write to the DRAM with any of four cycles: early write, late write, static column mode early write, and static column mode read-write. Early and late write modes are discussed here, while static column mode write operations are covered in another section.

A write cycle begins as described in **ADDRESSING THE RAM**. Write mode is enabled by the transition of $\overline{\text{W}}$ to active (V_{IL}). Early and late write modes are distinguished by the active transition of $\overline{\text{W}}$, with respect to $\overline{\text{CS}}$ leading edge. Minimum active time t_{RAS} and t_{CS} , and precharge time t_{RP} apply to write mode, as in the read mode.

An early write cycle is characterized by $\overline{\text{W}}$ active transition at minimum time t_{WCS} before $\overline{\text{CS}}$ active transition. Column address set up and hold times (t_{ASC} , t_{CAH}), and data in (D) set up and hold times (t_{DS} , t_{DH}) are referenced to $\overline{\text{CS}}$ in an early write cycle. $\overline{\text{RAS}}$ and $\overline{\text{CS}}$ clocks must stay active for t_{RWL} and t_{CWL} , respectively, after the start of the early write operation to complete the cycle.

Q remains in three-state condition throughout an early write cycle because $\overline{\text{W}}$ active transition precedes or coincides with $\overline{\text{CS}}$ active transition, keeping data-out buffers and $\overline{\text{G}}$ disabled.

A late write cycle (referred to as $\overline{\text{G}}$ -controlled write) occurs when $\overline{\text{W}}$ active transition is made after $\overline{\text{CS}}$ active transition. $\overline{\text{W}}$ active transition could be delayed for almost 10 microseconds after $\overline{\text{CS}}$ active transition, ($t_{\text{RCD}} + t_{\text{CWD}} + t_{\text{RWL}} + 2t_{\text{T}} \leq t_{\text{RAS}}$, if other timing minimums (t_{RCD} , t_{RWL} , and t_{T}) are maintained. Column address and D timing parameters are referenced to $\overline{\text{W}}$ active transition in a late write cycle. Output buffers are enabled by $\overline{\text{CS}}$ active transition but Q may be indeterminate — see note 18 of AC Operating Conditions table. Parameters t_{RWL} and t_{CWL} also apply to late write cycles.

READ-WRITE CYCLE

A read-write cycle performs a read and then a write at the same address, during the same cycle. This cycle is basically a late write cycle, as discussed in the **WRITE CYCLE** section, except $\overline{\text{W}}$ must remain high for t_{CWD} and/or t_{AWD} minimum, to guarantee valid Q before writing the bit.

STATIC COLUMN MODE CYCLES

Static column mode refers to multiple successive data operations performed at any or all 1024 column locations on the selected row of the 1M x 4 dynamic RAM during one $\overline{\text{RAS}}$ cycle. Read access time of multiple operations (t_{AA} or t_{CAC}) is considerably faster than the regular $\overline{\text{RAS}}$ clock access time t_{RAC} . Multiple operations can be performed simply by keeping $\overline{\text{RAS}}$ active. $\overline{\text{CS}}$ may be toggled between active and inactive states at any time within the $\overline{\text{RAS}}$ cycle.

Once the timing requirements for the initial read, write, or read-write cycle are met and $\overline{\text{RAS}}$ remains low, the device is ready for the next operation. Operations can be intermixed in any order, at any column address, subject to normal operating conditions previously described. Every write operation must be clocked with either $\overline{\text{CS}}$ or $\overline{\text{W}}$, as indicated in **static column mode early write cycle** timing diagrams A and B.

Column address and D timing parameters are referenced to the signal clocking the write operation. \overline{CS} must be toggled inactive (t_{CP}) to perform a read operation after an early write operation (to turn output on), as indicated in **static column mode read/write mixed cycle** timing diagram. The maximum number of consecutive operations is limited to t_{RASC} . The cycle ends when \overline{RAS} transitions to inactive.

REFRESH CYCLES

The dynamic RAM design is based on capacitor charge storage for each bit in the array. This charge will tend to degrade with time and temperature. Each bit must be periodically **refreshed** (recharged) to maintain the correct bit state. Bits in the MCM54402A require refresh every 16 milliseconds.

This is accomplished by cycling through the 1024 row addresses in sequence within the specified refresh time. All the bits on a row are refreshed simultaneously when the row is addressed. Distributed refresh implies a row refresh every 15.6 microseconds for the MCM54402A. Burst refresh, a refresh of all 1024 rows consecutively, must be performed every 16 milliseconds on the MCM54402A.

A normal read, write, or read-write operation to the RAM will refresh all the bits (4096) associated with the particular row decoded. Three other methods of refresh, **RAS-only refresh**, **\overline{CS} before \overline{RAS} refresh**, and **hidden refresh** are available on this device for greater system flexibility.

\overline{RAS} -Only Refresh

\overline{RAS} -only refresh consists of \overline{RAS} transition to active, latching the row address to be refreshed, while \overline{CS} remains high (V_{IH}) throughout the cycle. An external counter is employed to ensure all rows are refreshed within the specified limit.

\overline{CS} Before \overline{RAS} Refresh

\overline{CS} before \overline{RAS} refresh is enabled by bringing \overline{CS} active before \overline{RAS} . This clock order activates an internal refresh counter that generates the row address to be refreshed. External address lines are ignored during the automatic refresh cycle.

The output buffer remains at the same state it was in during the previous cycle (hidden refresh). \overline{W} must be inactive for time t_{WRP} before and time t_{WRH} after \overline{RAS} active transition to prevent switching the device into **test mode**.

Hidden Refresh

Hidden refresh allows refresh cycles to occur while maintaining valid data at the output pin. Holding \overline{CS} active the end of a read or write cycle, while \overline{RAS} cycles inactive for t_{RP} and back to active, starts the hidden refresh. This is essentially the execution of a \overline{CS} before \overline{RAS} refresh from a cycle in progress (see Figure 1). \overline{W} is subject to the same conditions with respect to \overline{RAS} active transition (to prevent test mode) as in \overline{CS} before \overline{RAS} refresh.

\overline{CS} BEFORE \overline{RAS} REFRESH COUNTER TEST

The internal refresh counter of this device can be tested with a **\overline{CS} before \overline{RAS} refresh counter test**. This test is performed with a read-write operation. During the test, the internal refresh counter generates the row address, while the external address supplies the column address. The entire array is refreshed after 1024 cycles, as indicated by the check data written in each row. See **\overline{CS} before \overline{RAS} refresh counter test cycle timing diagram**.

The test can be performed after a minimum of 8 \overline{CS} before \overline{RAS} initialization cycles. Test procedure:

1. Write "0"s into all memory cells with normal write mode.
2. Select a column address, read "0" out and write "1" into the cell by performing the **\overline{CS} before \overline{RAS} refresh counter test, read-write cycle**. Repeat this operation 1024 times.
3. Read the "1"s which were written in step 2 in normal read mode.
4. Using the same starting column address as in step 2, read "1" out and write "0" into the cell by performing the **\overline{CS} before \overline{RAS} refresh counter test, read-write cycle**. Repeat this operation 1024 times.
5. Read "0" which were written in step 4 in normal read mode.
6. Repeat steps 1 to 5 using complement data.

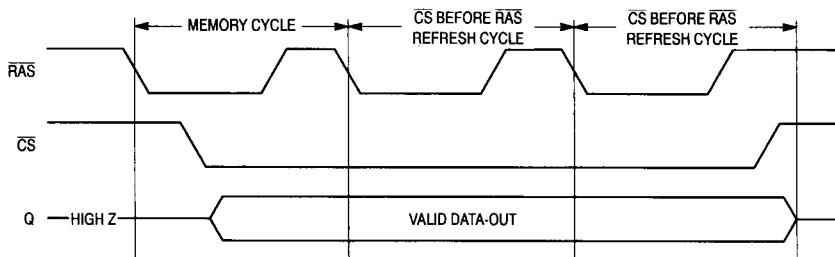

Figure 1. Hidden Refresh Cycle

TEST MODE

The internal organization of this device (512 x 8) allows it to be tested as if it were a 512K x 4 DRAM. Nineteen of the twenty addresses are used when operating the device in test mode. Column address A0 is ignored by the device in test mode. A test mode cycle reads and/or writes data to a bit in each of eight 512K blocks (B0 – B7) in parallel. External data out is determined by the internal test mode logic of

the device. See the following truth table and test mode block diagram.

\bar{W} , \bar{CS} before \bar{RAS} timing puts the device in **Test Mode**, as shown in the test mode timing diagram. A \bar{CS} before **RAS refresh cycle** or a **RAS-only refresh cycle** puts the device back in normal mode. Refresh is performed in test mode by using a \bar{W} , \bar{CS} before **RAS refresh cycle** which uses the internal refresh address counter.

TEST MODE TRUTH TABLE

D	B0, B1	B2, B3	B4, B5	B6, B7	Q
0	0	0	0	0	1
1	1	1	1	1	1
—	Any Other				0

TEST MODE

AC OPERATING CONDITIONS AND CHARACTERISTICS

($V_{CC} = 5.0 \text{ V} \pm 10\%$, $T_A = 0 \text{ to } 70^\circ\text{C}$, Unless Otherwise Noted)

READ, WRITE, AND READ-WRITE CYCLES (See Notes 1, 2, 3, and 4)

Parameter	Symbol		MCM54402A-60		MCM54402A-70		MCM54402A-80		Unit	Notes
	Std	Alt	Min	Max	Min	Max	Min	Max		
Random Read or Write Cycle Time	t_{RELREL}	t_{RC}	115	—	135	—	155	—	ns	5
Static Column Mode Cycle Time	t_{AVAV}	t_{SC}	40	—	45	—	50	—	ns	
Access Time from \bar{RAS}	t_{RELQV}	t_{RAC}	—	65	—	75	—	85	ns	6, 7
Access Time from \bar{CS}	t_{CELQV}	t_{CAC}	—	25	—	25	—	25	ns	6, 8
Access Time from Column Address	t_{AVQV}	t_{AA}	—	35	—	40	—	45	ns	6, 9
\bar{RAS} Pulse Width	t_{RELREH}	t_{RAS}	65	10 k	75	10 k	85	10 k	ns	
\bar{RAS} Pulse Width (Static Column Mode)	t_{RELREH}	t_{RASC}	65	200 k	75	200 k	85	200 k	ns	
\bar{RAS} Hold Time	t_{CELREH}	t_{RSH}	25	—	25	—	25	—	ns	
\bar{CS} Hold Time	t_{RELCEH}	t_{CSH}	65	—	75	—	85	—	ns	
\bar{CS} Pulse Width	t_{CELCEH}	t_{CS}	25	10 k	25	10 k	25	10 k	ns	
\bar{CS} Pulse Width (Static Column Mode)	t_{CELCEH}	t_{CSC}	25	200 k	25	200 k	25	200 k	ns	
Column Address to \bar{RAS} Lead Time	t_{AVREH}	t_{RAL}	35	—	40	—	45	—	ns	

NOTES:

- V_{IH} (min) and V_{IL} (max) are reference levels for measuring timing of input signals. Transition times are measured between V_{IH} and V_{IL} .
- An initial pause of 200 μs is required after power-up followed by 8 \bar{RAS} cycles before proper device operation is guaranteed.
- The transition time specification applies for all input signals. In addition to meeting the transition rate specification, all input signals must transition between V_{IH} and V_{IL} (or between V_{IL} and V_{IH}) in a monotonic manner.
- AC measurements $t_T = 5.0 \text{ ns}$.
- The specification for t_{RC} (min) is used only to indicate cycle time at which proper operation over the full temperature range ($0^\circ\text{C} \leq T_A \leq 70^\circ\text{C}$) is ensured.
- Measured with a current load equivalent to 2 TTL ($-200 \mu\text{A}$, $+4 \text{ mA}$) loads and 100 pF with the data output trip points set at $V_{OH} = 2.0 \text{ V}$ and $V_{OL} = 0.8 \text{ V}$.
- Assumes that $t_{RCD} \leq t_{RCD}(\text{max})$.
- Assumes that $t_{RCD} \geq t_{RCD}(\text{max})$.
- Assumes that $t_{RAD} \geq t_{RAD}(\text{max})$.

\bar{W} , \bar{CS} BEFORE \bar{RAS} REFRESH CYCLE (TEST MODE ENTRY)
 (\bar{G} and A0 - A9 are Don't Care)

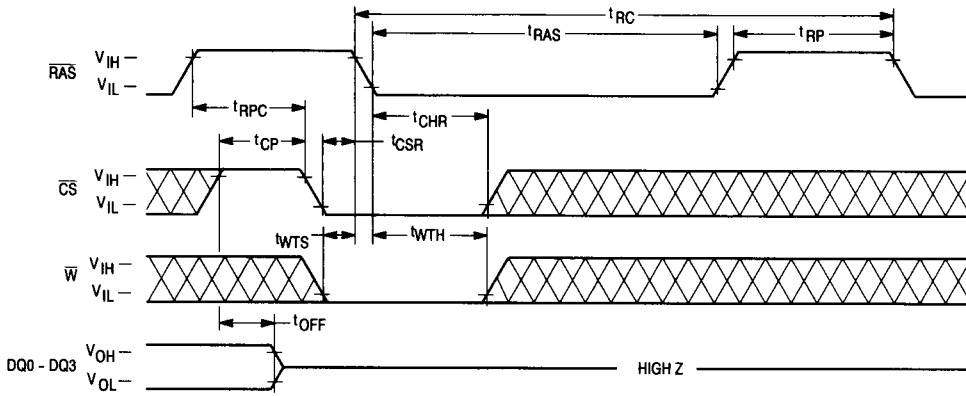

TEST MODE — READ CYCLE

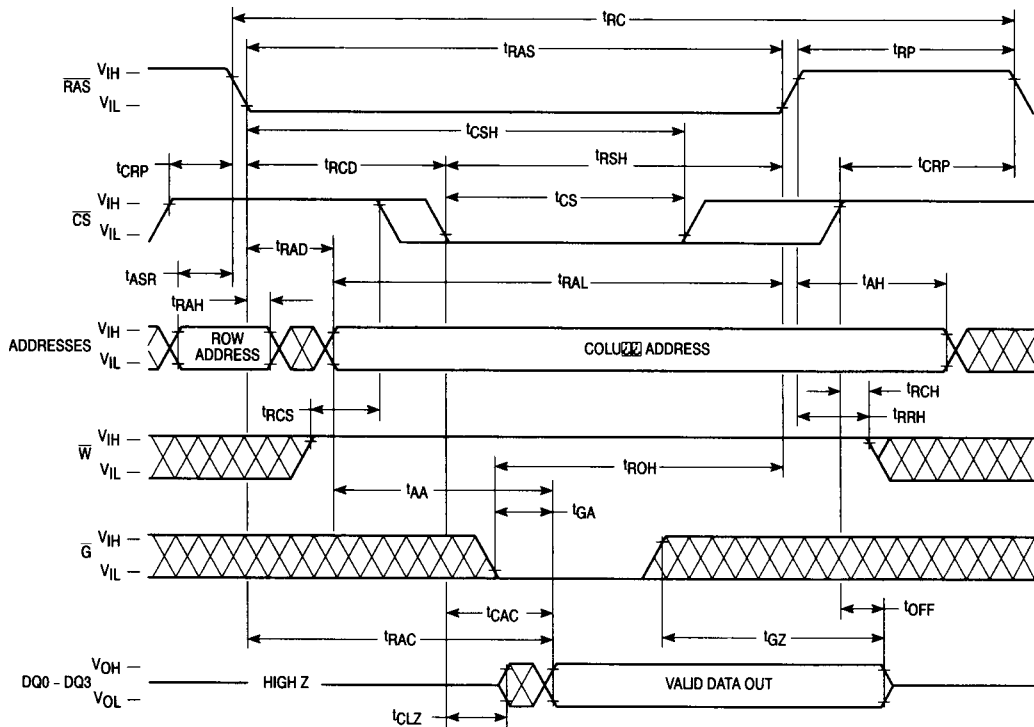

TEST MODE — EARLY WRITE CYCLE

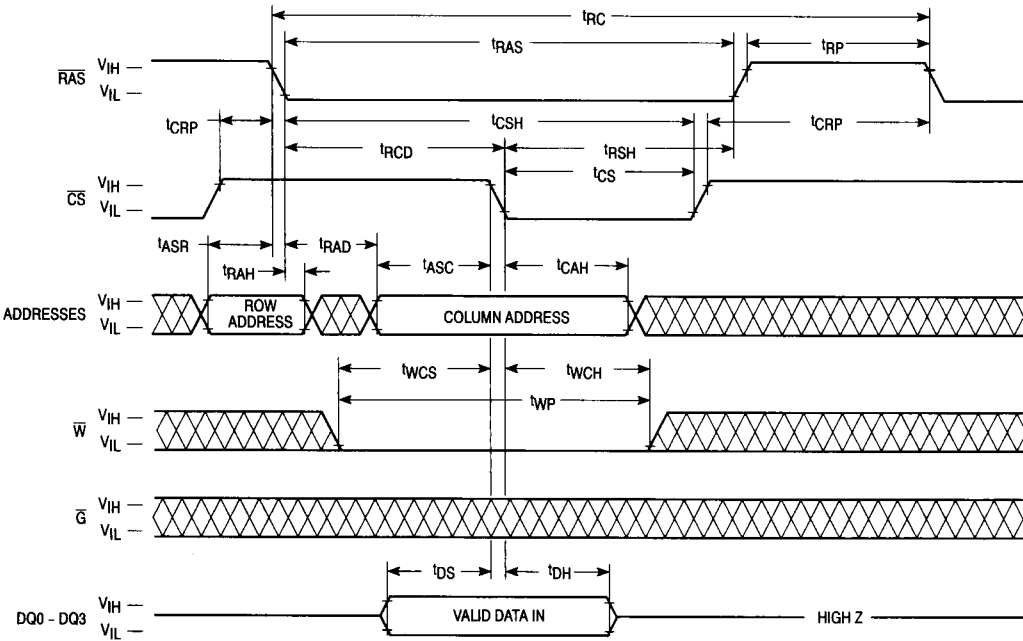

TEST MODE — STATIC COLUMN MODE READ CYCLE

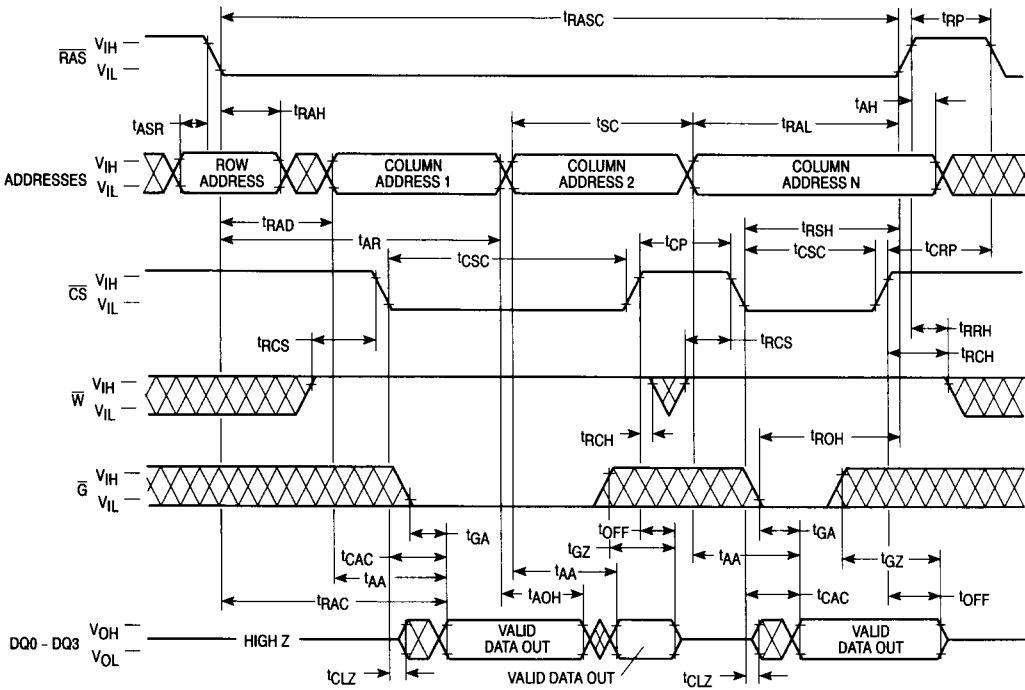

TEST MODE – STATIC COLUMN MODE EARLY WRITE CYCLE (A)

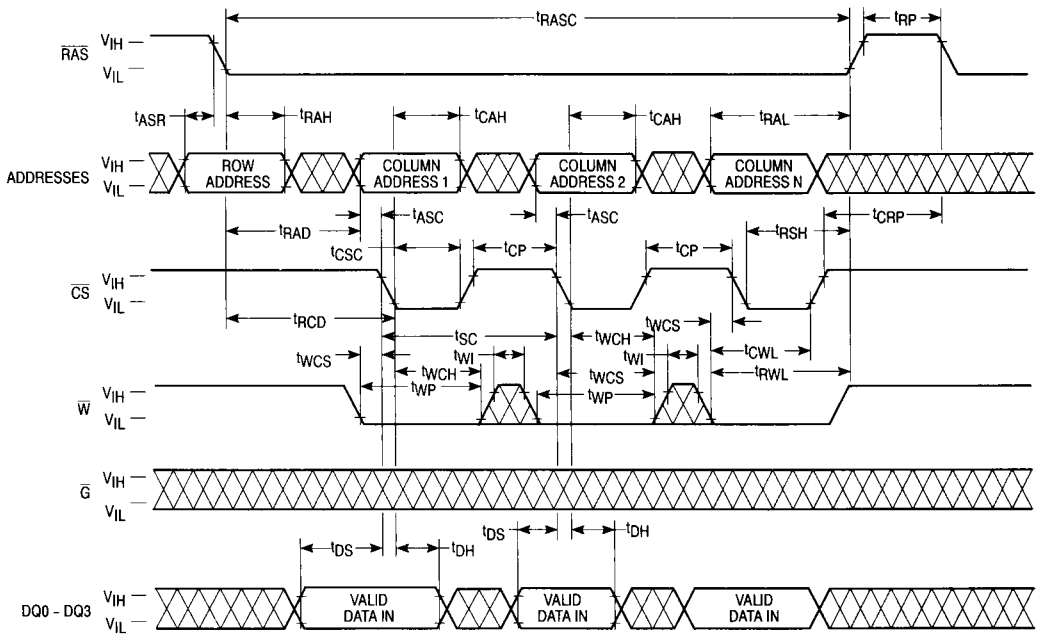

TEST MODE – STATIC COLUMN MODE EARLY WRITE CYCLE (B)

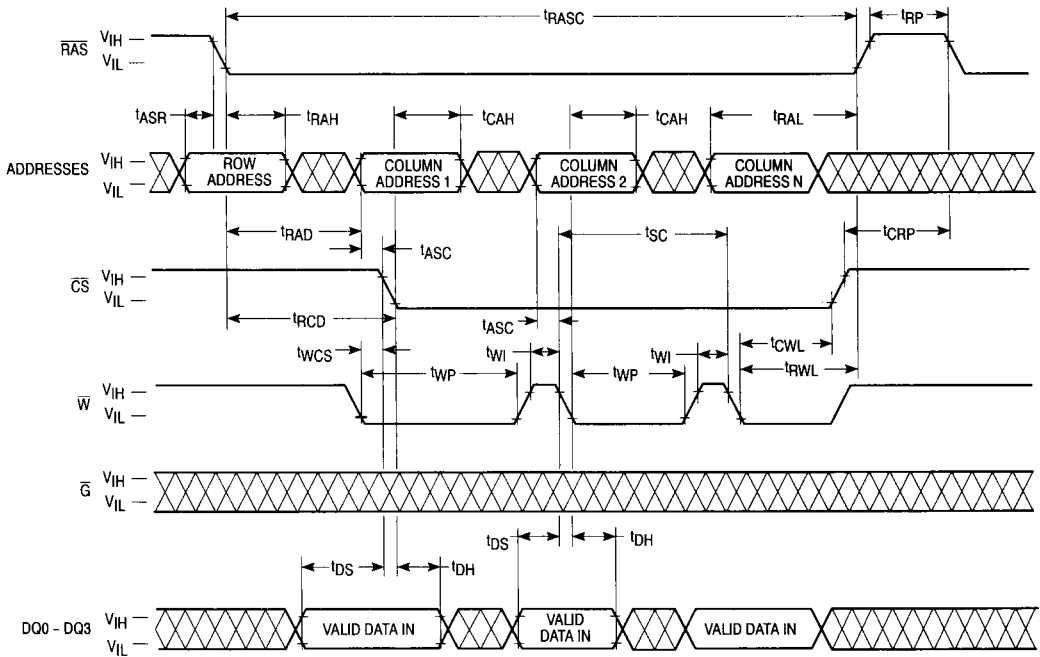

TEST MODE BLOCK DIAGRAM

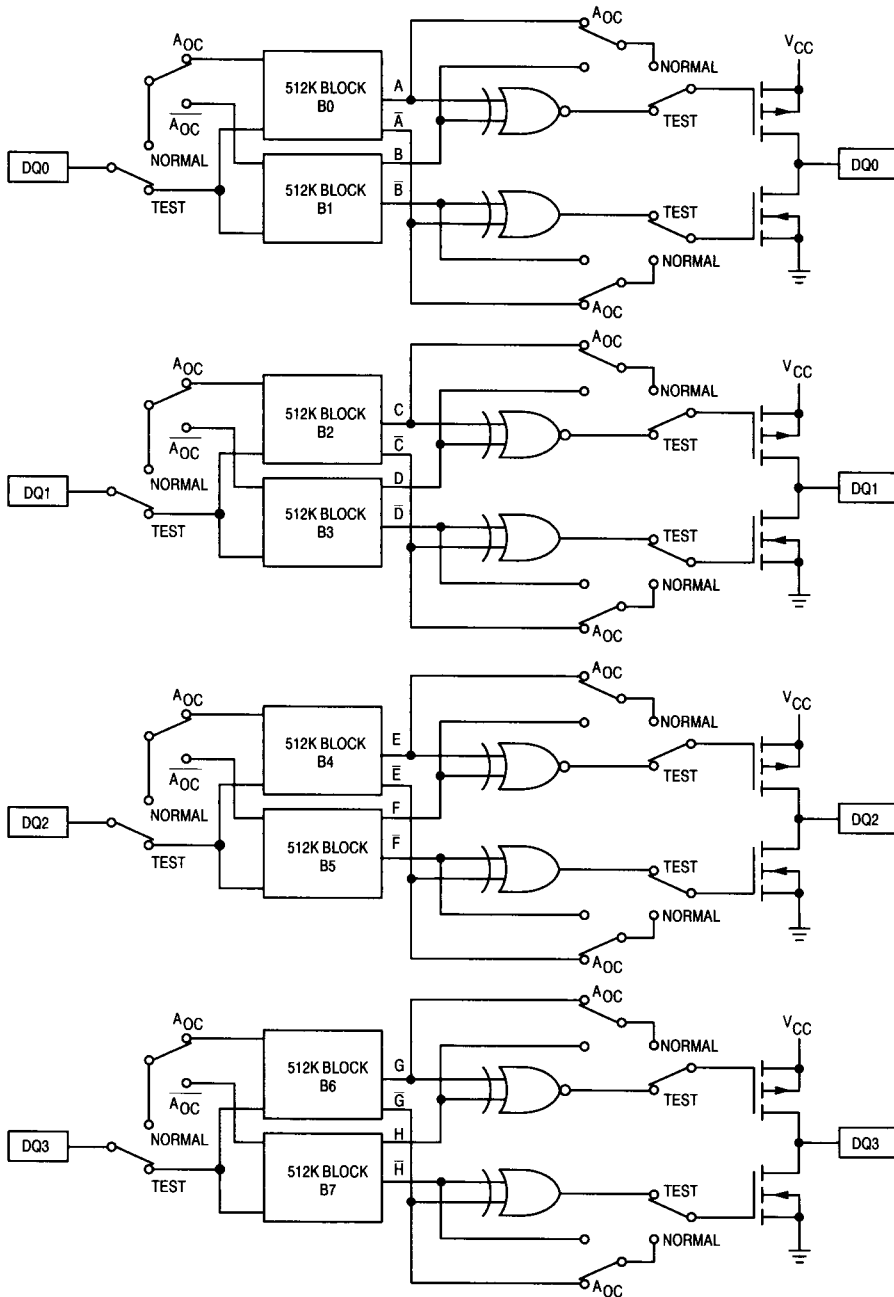

ORDERING INFORMATION
(Order by Full Part Number)

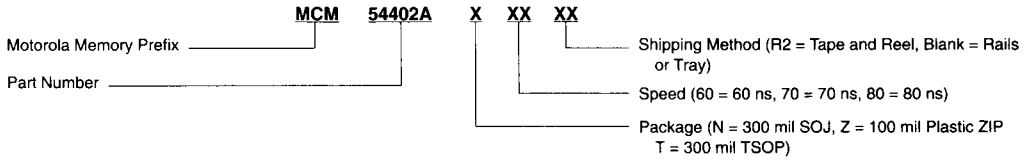

Full Part Numbers —	MCM54402AN60	MCM54402AN60R2	MCM54402AZ60	MCM54402AT60
	MCM54402AN70	MCM54402AN70R2	MCM54402AZ70	MCM54402AT70
	MCM54402AN80	MCM54402AN80R2	MCM54402AZ80	MCM54402AT80

NOTE: For mechanical data, please see Chapter 10.