

## Film dielectric trimmers

2222 808 .....  
 Ø7.5 mm

### FEATURES

- Housing diameter 7.5 mm
- For a basic grid of 2.54 mm (0.1") or 2.50 mm
- Top and bottom or top adjustment
- Vertical and horizontal versions
- Round or hexagonal head.

### APPLICATIONS

- For consumer and industrial equipment.

### DESCRIPTION

The vanes of the trimmer are stacked on a sturdy plastic base. The colour of the base indicates the maximum capacitance (see Table 2). The dielectric is a film of polypropylene (PP), polyethylene (PE), polycarbonate (PC), polytetrafluorethylene (PTFE), or polyethyleneterephthalate (PET) which supports the vanes in such a way that good stability is ensured and no microphony can occur.

Flux absorption between the vanes is prevented.

Cleaning with solvents is not advised.

Versions are available with either a vertical spindle (see Fig.1), or a horizontal spindle (see Fig.2). Both versions have top adjustment by means of a screwdriver or trimming key and bottom adjustment by means of a key as shown in Fig.5.

For outline drawings and dimensions see Figs 1 and 2.

### QUICK REFERENCE DATA

DESCRIPTION	VALUE
$C_{min}/C_{max}$	1.4/5.5 to 3/50 pF
Rated voltage (DC)	250 V
Test voltage (DC) for 1 minute	500 V
Maximum contact resistance	10 mΩ
Minimum insulation resistance	10000 MΩ
Category temperature range:	
PP	-40 to +70 °C
PE, PC, PTFE, PET	-40 to +85 °C
Climatic category (IEC 60068):	
PP	40/070/21
PE, PC, PTFE, PET	40/085/21
Minimum storage temperature	-55 °C
Related specification	IEC 60418-1 and 4

### MECHANICAL DATA

DESCRIPTION	VALUE
Effective angle of rotation	180°
Operating torque:	
$C_{max} < 33$ pF	1 to 15 mNm
$C_{max} \geq 33$ pF	1 to 25 mNm
Maximum axial thrust	2 N

### QUALITY LEVEL

Sampling and data evaluation for quality level in accordance with "MIL-STD-105D" and "IEC 60410":

- <0.15% major defects
- <0.65% minor defects.

Each capacitor is tested for minimum  $C_{max}$  and is also subjected to the full test voltage.

Film dielectric trimmers

2222 808 .....  
Ø7.5 mm

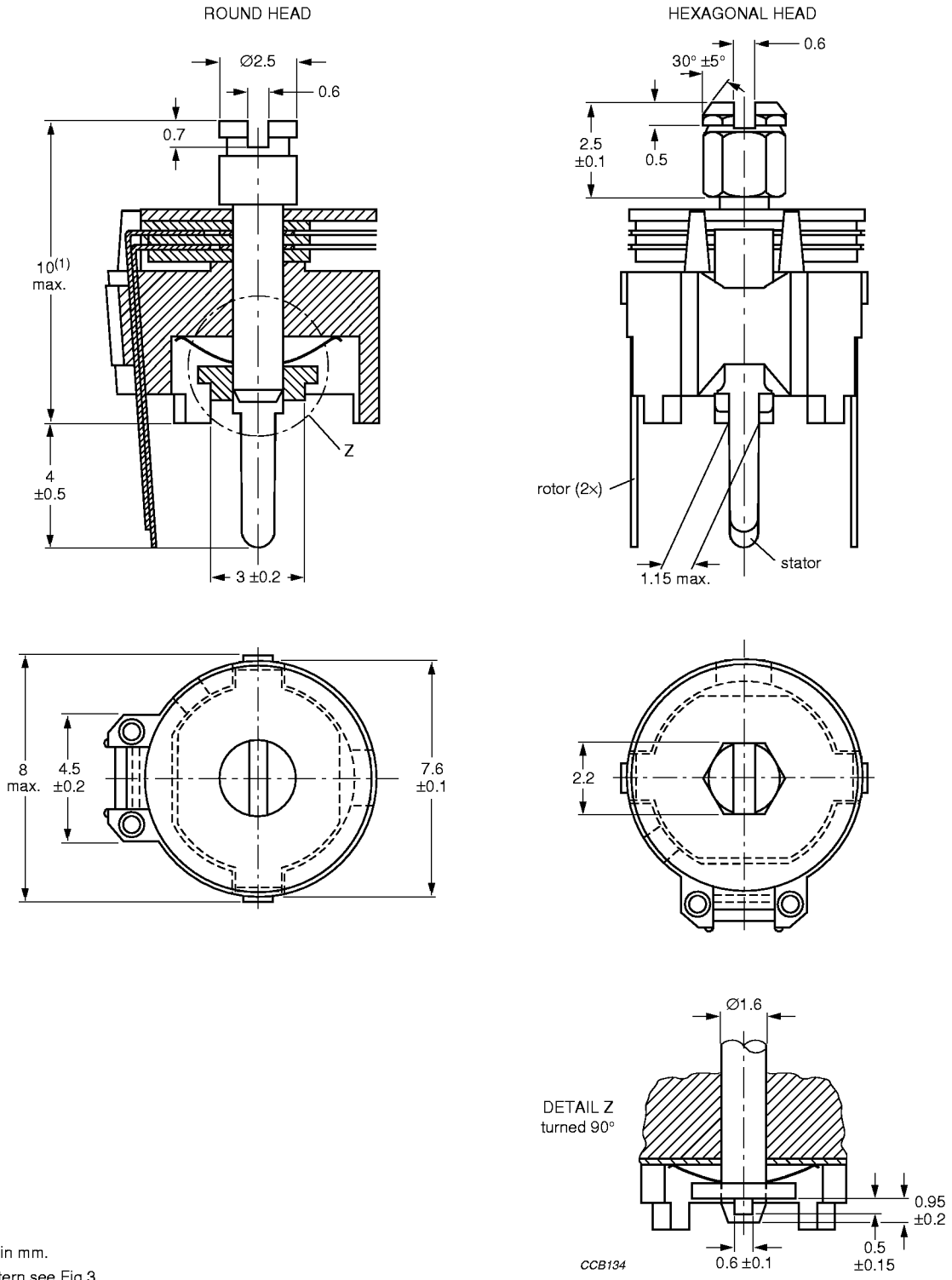

Dimensions in mm.  
For hole pattern see Fig.3.  
(1) 11 max. for  $C_{\text{max}} = 40 \text{ pF}$  and  $50 \text{ pF}$ .

Fig.1 Trimmers 2222 808 ..... series, vertical version.

Film dielectric trimmers

2222 808 .....  
 Ø7.5 mm

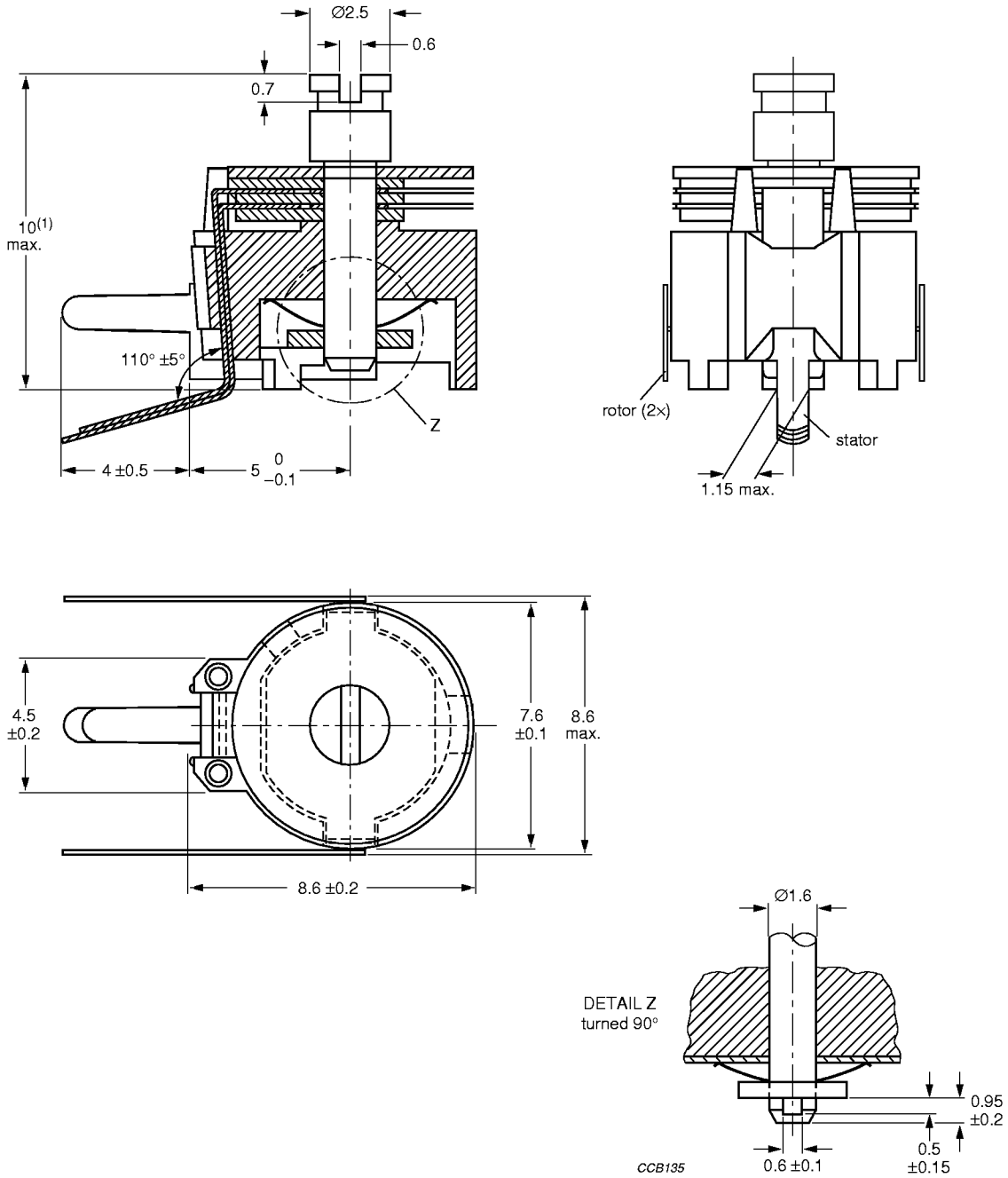

Dimensions in mm.

For hole pattern see Fig.4.

(1) 11 max. for  $C_{max} = 40 \text{ pF}$  and  $50 \text{ pF}$ .

Fig.2 Trimmers 2222 808 ..... series, horizontal version.

Film dielectric trimmers

2222 808 .....  
 Ø7.5 mm

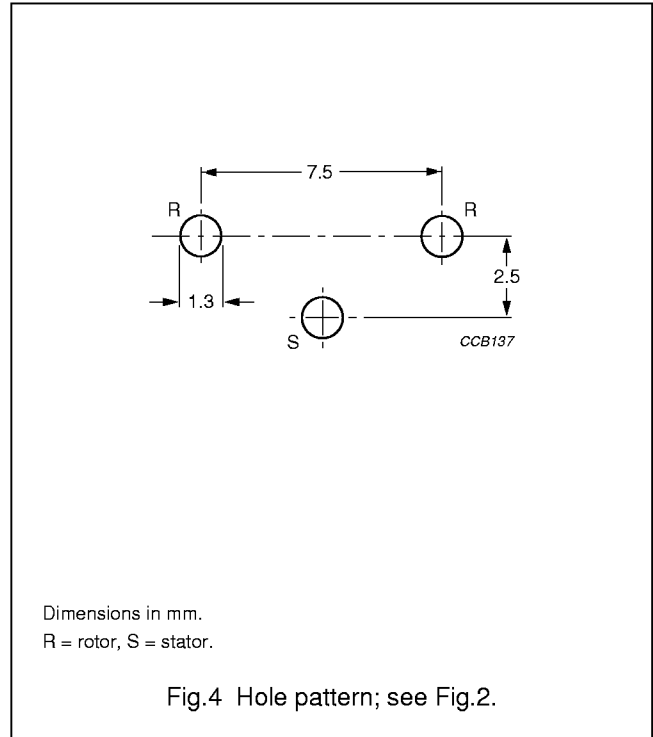
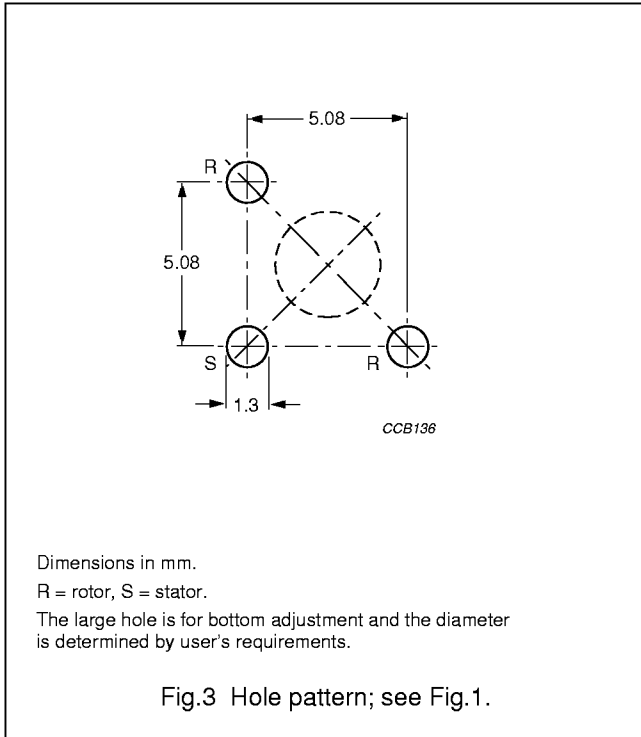

**Adjustment**

For top adjustment a screwdriver or trimming key can be used; for bottom adjustment a key is required as shown in Fig.5.

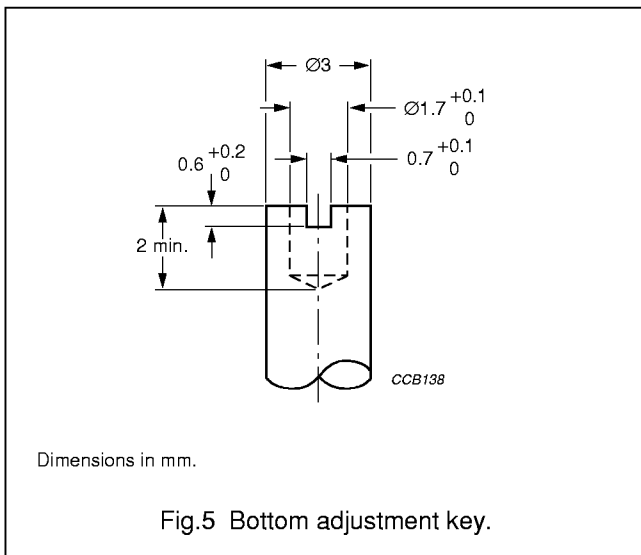

## Film dielectric trimmers

2222 808 .....  
Ø7.5 mm**ORDERING INFORMATION****Table 1** Selection chart

$C_{\min}/C_{\max}$ (pF)	CATALOGUE NUMBER 2222 808 .....			
	VERTICAL VERSION			HORIZONTAL VERSION
	ROUND HEAD		HEXAGONAL HEAD	ROUND HEAD
	TOP AND BOTTOM ADJUSTMENT	TOP ADJUSTMENT ONLY	TOP AND BOTTOM ADJUSTMENT	TOP AND BOTTOM ADJUSTMENT
1.4/5.5	11558	00004	–	51558
2/9	00018	–	–	–
2/10	11109	00005	17109	51109
2/10	–	11004	–	–
2/15	11159	–	–	–
2/18	00016	–	–	–
2.5/20	–	11006	–	–
2.5/22	11229	00006	17229	51229
2.5/27	11279	–	–	51279
3/33	11339	–	–	–
3/40	11409	–	17409	51409
3/50	11509	–	17509	51509

**MOUNTING**

The trimmer can be mounted on printed-circuit boards with a grid of 2.50 mm or 2.54 mm and a minimum hole diameter of 1.25 mm. For hole patterns see Figs 3 and 4.

**PACKAGING**

Bulk packaged in cardboard boxes lined with expanded plastic. For smallest packaging quantity (SPQ) see Table 2.

Film dielectric trimmers

2222 808 .....  
 Ø7.5 mm

**ELECTRICAL DATA**

**Table 2** Electrical characteristics, smallest packaging quantities and catalogue numbers

GUARANTEED MAX. C <sub>min</sub> / MIN. C <sub>max</sub> at 200 kHz (pF)	SPINDLE	SHAPE OF HEAD	FIG.	ADJ. MODE	DIEL.	tan δ at C <sub>max</sub> × 10 <sup>-4</sup>		TEMP. COEFF. (10 <sup>-6</sup> /K)	MIN. f <sub>res</sub> at C <sub>max</sub> (MHz)	COL. OF BASE	SPQ	CATALOGUE NUMBER
						1 MHz	100 MHz					
1.4/5.5	vertical	round	1	top + bottom	PE	≤10	≤25	-250 ±350	850	grey	1400	2222 808 11558
	horizontal	round	1	top							1400	2222 808 00004
2/9	vertical	round	2	top + bottom	PTFE	≤10	≤15	-150 ±800	400	yellow	1200	2222 808 51558
	vertical	round	1	top + bottom	PP	≤10	≤25	-250 ±800	480	yellow	1400	2222 808 00018
horizontal	round	1	top	1400							2222 808 11109	
2/10	vertical	hexag.	1	top	PP	≤10	≤25	-250 ±800	480	yellow	1400	2222 808 00005
	horizontal	round	1	top							1400	2222 808 17109
2/15	vertical	round	2	top + bottom	PC	≤70	≤100	-150 ±800	250	yellow	1000	2222 808 11004
	horizontal	round	1	top							1400	2222 808 11159
2/18	vertical	round	1	top + bottom	PP	≤10	≤25	-250 ±600	450	blue	1400	2222 808 11159
	horizontal	round	1	top	PTFE	≤10	≤15	-250 ±350	350	green	1400	2222 808 00016
2.5/20	vertical	round	1	top	PET	≤160	-	0 ±1 100	250	green	1000	2222 808 11006
	horizontal	round	1	top + bottom	PP	≤10	≤25	-200 ±500	350	green	1400	2222 808 11229
vertical	round	1	top	1400							2222 808 00006	
2.5/22	vertical	hexag.	1	top	PP	≤10	≤25	-200 ±500	350	green	1400	2222 808 17229
	horizontal	round	2	top + bottom							1200	2222 808 51229
2.5/27	vertical	round	1	top + bottom	PC	≤70	-	-50 ±500	350	red	1400	2222 808 11279
	horizontal	round	2	top + bottom							1200	2222 808 51279
3/33	vertical	round	1	top + bottom	PP	≤10	-	-250 ±350	300	brown	1400	2222 808 11339
	horizontal	round	1	top + bottom	PC	≤70	-	-50 ±400	300	violet	1400	2222 808 11409
vertical	hexag.	1	top	1400							2222 808 17409	
3/40	vertical	round	2	top + bottom	PC	≤70	-	-50 ±400	300	violet	1200	2222 808 51409
	horizontal	round	1	top + bottom							1400	2222 808 11509
3/50	vertical	hexag.	1	top	PC	≤70	-	-50 ±500	250	black	1400	2222 808 17509
	horizontal	round	2	top + bottom							1200	2222 808 51509

## Film dielectric trimmers

2222 808 .....  
Ø7.5 mm

## TESTS AND REQUIREMENTS

Table 3 Test procedures and requirements

IEC 60418-1 CLAUSE	IEC 60068 TEST METHOD	TEST	PROCEDURE	REQUIREMENTS
4.2		method of mounting	method A	
14		capacitance drift	after TC measurement	$\Delta C/C: \leq 1\%$ for $C_{\max} < 40$ pF; $\Delta C/C: \leq 2.5\%$ for $C_{\max} \geq 40$ pF
19		thrust	axial thrust of 2 N	$\Delta C/C: \leq 0.3\%$
21		robustness of terminations:		
21.1	Ua	tensile	1 N	no damage
21.2	Ub	bending	1 cycle	no damage
22	Na	rapid change of temperature	1 cycle; 0.5 hours at lower and 0.5 hours at upper category temperature	$\Delta C/C: \leq 2\%$
23	T	soldering:		
	Ta	solderability	solder bath immersion 3 mm; 235 °C; 2 s	good wetting no mechanical damage
	Tb	resistance to heat	solder bath: 260 °C; 10 s	no mechanical damage
24	Eb	impact bump	4000 ±10 bumps; 40 g; 6 ms	$\Delta C/C: \leq 0.6\%$ ; no mechanical damage
25	Fc	vibration	frequency 10 to 55 Hz; amplitude 0.35 mm; 1.5 hours	$\Delta C/C: \leq 0.6\%$ ; no mechanical damage
26		climatic sequence:		$\Delta C/C: \leq 4$
26.1	B	dry heat	16 hours at upper category temperature	$\tan \delta: \leq 10 \times 10^{-4}$ for $C_{\max} < 27$ pF; $\tan \delta: \leq 70 \times 10^{-4}$ for $C_{\max} \geq 27$ pF; $\tan \delta: \leq 80 \times 10^{-4}$ for $C_{\max} \geq 40$ pF $R_{\text{ins.}}: \geq 10000$ MΩ; rotor contact R: $\leq 10$ mΩ
26.2	D	damp heat accelerated, first cycle	1 cycle; 24 hours; +40 °C; 95 to 100% RH	voltage proof: 500 V for 1 minute
26.3	Aa	cold	16 hours; -40 °C	visual examination: no mechanical damage
26.5		damp heat accelerated, remaining cycles	1 cycle; 24 hours; +40 °C; 95 to 100% RH	operating torque: 1 to 15 mNm for $C_{\max} < 33$ pF; 1 to 25 mNm for $C_{\max} \geq 33$ pF

## Film dielectric trimmers

2222 808 .....  
Ø7.5 mm

IEC 60418-1 CLAUSE	IEC 60068 TEST METHOD	TEST	PROCEDURE	REQUIREMENTS
27	Ca	damp heat steady state	21 days; +40 °C; 90 to 95% RH	$\Delta C/C: \leq 5\%$ $\tan \delta: \leq 30 \times 10^{-4}$ for $C_{\max} < 27$ pF; $\tan \delta: \leq 70 \times 10^{-4}$ for $C_{\max} \geq 27$ pF; $\tan \delta: \leq 80 \times 10^{-4}$ for $C_{\max} \geq 40$ pF $R_{\text{ins}}: \geq 10000$ M $\Omega$ ; rotor contact R: $\leq 10$ m $\Omega$ voltage proof: 500 V for 1 minute visual examination: no mechanical damage operating torque: 1 to 15 mNm for $C_{\max} < 33$ pF; 1 to 25 mNm for $C_{\max} \geq 33$ pF
29		mechanical endurance	10 cycles	$\Delta C/C: \leq 1.5\%$ $\Delta C/C$ after axial thrust: $\leq 0.3\%$ ; rotor contact R: $\leq 10$ m $\Omega$ voltage proof: 500 V for 1 minute visual examination: no mechanical damage operating torque: 1 to 15 mNm for $C_{\max} < 33$ pF; 1 to 25 mNm for $C_{\max} \geq 33$ pF