



CSP1027 Voice Band Codec for Cellular Handset and Modem Applications

1 Features

- Δ - Σ (delta-sigma) A/D and D/A converters with standard 16-bit serial I/O interface.
- On-chip filters meet ITU-T G.712 voice band frequency response and signal to distortion plus noise specifications. Suitable for IS-54, GSM, and JDC digital cellular applications.
- Low-profile package (<1.5 mm) 48-pin thin quad flat pack (TQFP) available or 44-pin EIAJ quad flat pack (QFP).
- Operates in systems with a 3.0 V to 5.0 V digital power supply and a 5.0 V analog supply.
- Low-power 0.9 μ m CMOS technology, fully static design, typical power of 68 mW when active and 0.05 mW in standby with a 3.3 V digital supply and a 5.0 V analog supply.
- A low-power inactive (standby) state without stopping clock or removing power supply.
- Sampling rates up to 24 kHz.
- On-chip programmable sampling clock generator allows input clock to be an integer multiple of 125 times the sampling rate or an integer multiple of the sampling rate.
- Programmable phase adjust of both codec sampling clock and baseband codec clock.
- Two on-chip clock dividers for generating the output clock for the baseband codec and the output clock for other processors.
- Regulated microphone power supply.
- Microphone preamplifier, with programmable input ranges of 0.16 V_p and 0.5 V_p.
- Output amplifier, with programmable gain settings, 0 dB to -45 dB in -3 dB steps.
- High-pass filters selectable via control registers.
- Power-on reset pulse generator.

- Standard 16-bit serial I/O interface.
- Serial I/O multiprocessor mode compatible with the Lucent Technologies Microelectronics Group's DSP16A and DSP1610/1616/1617/1618 Digital Signal Processors.

2 Description

The Lucent CSP1027 is a high-precision linear voice-band Δ - Σ (delta-sigma) codec designed for cellular handset and modem applications. The device is fabricated in low-power CMOS technology and designed for low-voltage (3.0 V to 5.0 V) digital systems. The CSP1027 is packaged in a 44-pin EIAJ quad flat pack (QFP) or a 48-pin EIAJ thin quad flat pack (TQFP). In the 48-pin TQFP, the CSP1027 occupies a total volume of 0.0784 cm³.

The CSP1027 has a variety of significant programmable features not found in standard voice band codecs. The analog interface includes a microphone preamplifier with programmable gain settings, an output amplifier with gain programmable in 3 dB steps over a 45 dB range, and a regulated microphone power supply. An inactive mode allows a low-power standby state, and a mute function provides suppression of the analog output. On-chip antialiasing and anti-imaging filtering includes a selectable high-pass filter. The CSP1027 meets ITU-T G.712 voice band specifications.

The programmable features of the CSP1027 are set by writing four on-chip control registers through the serial I/O interface. The codec's digital input/output uses a linear 16-bit two's complement data format that is also transferred through the serial I/O interface. The CSP1027 interfaces easily to the 16-bit serial ports of digital signal processors and other devices. The serial interface supports the Lucent fixed-point DSP family serial multiprocessor mode. This allows up to eight compatible devices, including two CSP1027s, to interface to each other on a common 4-wire bus using a time-division-multiplexing scheme.

Table of Contents

Contents	Page
1 Features	1
2 Description	1
3 Pin Information	3
4 Architectural Information	5
4.1 Overview	6
4.2 Description of Signal Paths	6
4.3 Programmable Features	13
4.4 Power-On Reset	14
4.5 Clock Generation	16
4.6 Serial I/O Configurations	20
5 Register Information	26
5.1 Codec I/O Control 0 (cioc0) Register	26
5.2 Codec I/O Control 1 (cioc1) Register	27
5.3 Codec I/O Control 2 (cioc2) Register	28
5.4 Codec I/O Control 3 (cioc3) Register	29
6 Signal Descriptions	30
6.1 Clock Interface	30
6.2 Reset Interface	31
6.3 Serial I/O Interface	31
6.4 External Gain Control Interface	32
6.5 Digital Power and Ground	32
6.6 Analog Interface	32
6.7 Analog Power and Ground	32
7 Application Information	33
7.1 Analog Information	33
7.2 Power Supply Configuration	36
7.3 The Need for Fully Synchronous Operation	36
7.4 Crystal Oscillator	38
7.5 Programmable Clock Generation	45
8 Device Characteristics	47
8.1 Absolute Maximum Ratings	47
8.2 Handling Precautions	47
8.3 Recommended Operating Conditions	47
9 Electrical Characteristics and Requirements	48
9.1 Power Dissipation	50
10 Analog Characteristics and Requirements	51
10.1 Analog Input and Microphone Regulator	51
10.2 Analog-to-Digital Path	52
10.3 Digital-to-Analog Path	53
10.4 Miscellaneous	54
11 Timing Characteristics and Requirements	55
11.1 Clock Generation	56
11.2 Power-On Reset	57
11.3 Reset	58
11.4 Serial I/O Communication	59
11.5 Serial Multiprocessor Communication	61
12 Outline Diagrams	62
12.1 44-Pin EIAJ Quad Flat Pack (QFP)	62
12.2 48-Pin EIAJ Thin Quad Flat Pack (TQFP)	63

3 Pin Information

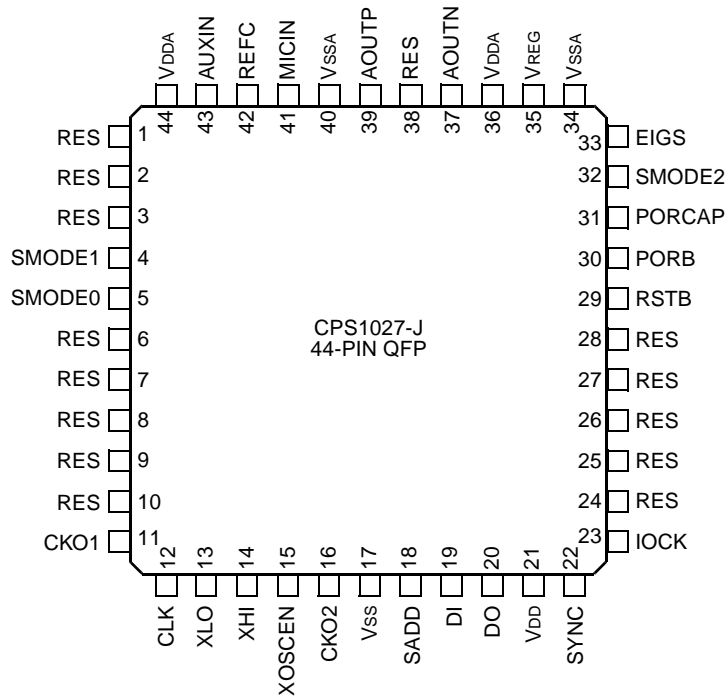

5-7567 (F)

Figure 1. 44-Pin EIAJ Quad Flat Pack (QFP) Pin Diagram

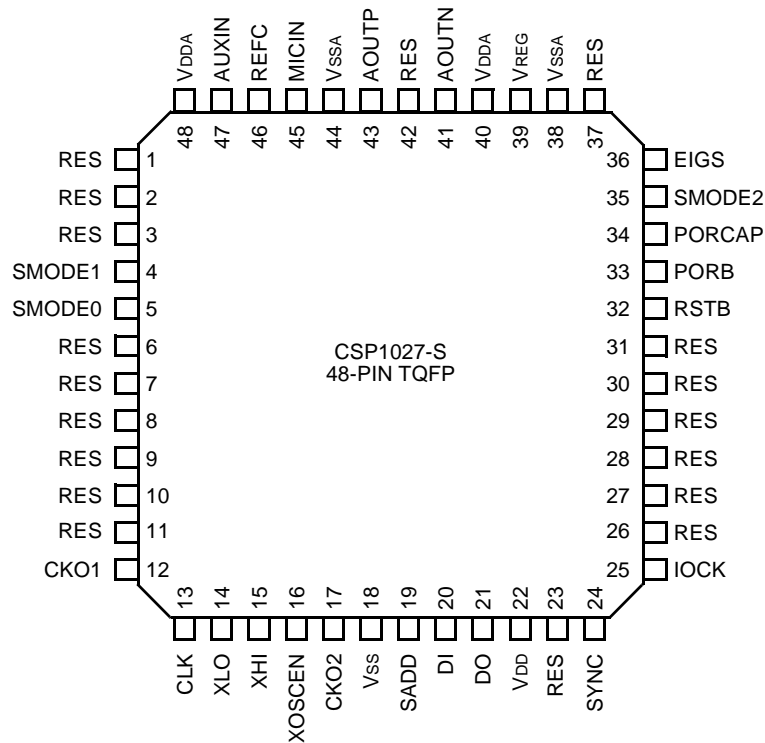

5-7568 (F)

Figure 2. 48-Pin EIAJ Thin Quad Flat Pack (TQFP) Pin Diagram

3 Pin Information (continued)

Functional descriptions of the pins are found in Section 6 on page 30.

Table 1. Pin Descriptions

QFP Pin	TQFP Pin	Symbol	Type	Name/Function
1, 2, 3	1, 2, 3	RES	NC*	Reserved.
4	4	SMODE1	I	Serial Mode Select 1.
5	5	SMODE0	I	Serial Mode Select 0.
6, 7, 8, 9, 10	6, 7, 8, 9, 10, 11	RES	NC*	Reserved.
11	12	CKO1	O	Clock Output 1.
12	13	CLK	I	Clock Input.
13	14	XLO	I	Crystal Input.
14	15	XHI	O	Crystal Output.
15	16	XOSCEN	I	Crystal Oscillator Enable.
16	17	CKO2	O	Clock Output 2.
17	18	Vss	P	Digital Ground.
18	19	SADD	I/O†	Serial Address.
19	20	DI	I	Serial Input Data.
20	21	DO	O†	Serial Output Data.
21	22	VDD	P	Digital Power Supply.
—	23	RES	NC*	Reserved.
22	24	SYNC	I/O†	Serial Input/Output Load Strobe and Synchronization.
23	25	ILOCK	I‡	Serial Clock.
24, 25, 26, 27, 28	26, 27, 28, 29, 30, 31	RES	NC*	Reserved.
29	32	RSTB	I	Reset.
30	33	PORB	O	Power-On Reset Output.
31	34	PORCAP	I§	External Capacitor Connection for Power-On Reset.
32	35	SMODE2	I	Serial Mode Select 2.
33	36	EIGS	I**	External Input Gain Select.
—	37	RES	NC*	Reserved.
34	38	VSSA	P	Analog Ground.
35	39	VREG	A	Regulated Output Voltage for Electret Condenser Microphone.
36	40	VDDA	P	Analog 5.0 V Power Supply.
37	41	AOUTN	A	Inverting Analog Output of Output Amplifier.
38	42	RES	NC*	Reserved.
39	43	AOUTP	A	Noninverting Analog Output of Output Amplifier.
40	44	VSSA	P	Analog Ground.
41	45	MICIN	A	Analog Input for Microphone.
42	46	REFC	A	External Capacitor Connection for Internal Voltage Regulator.
43	47	AUXIN	A	Analog Input from Auxiliary.
44	48	VDDA	P	Analog 5.0 V Power Supply.

* Indicates no connection.

† Indicates 3-state output.

‡ Indicates pull-up device on input.

§ Indicates pull-up resistor on input.

** Indicates pull-down device on input.

4 Architectural Information

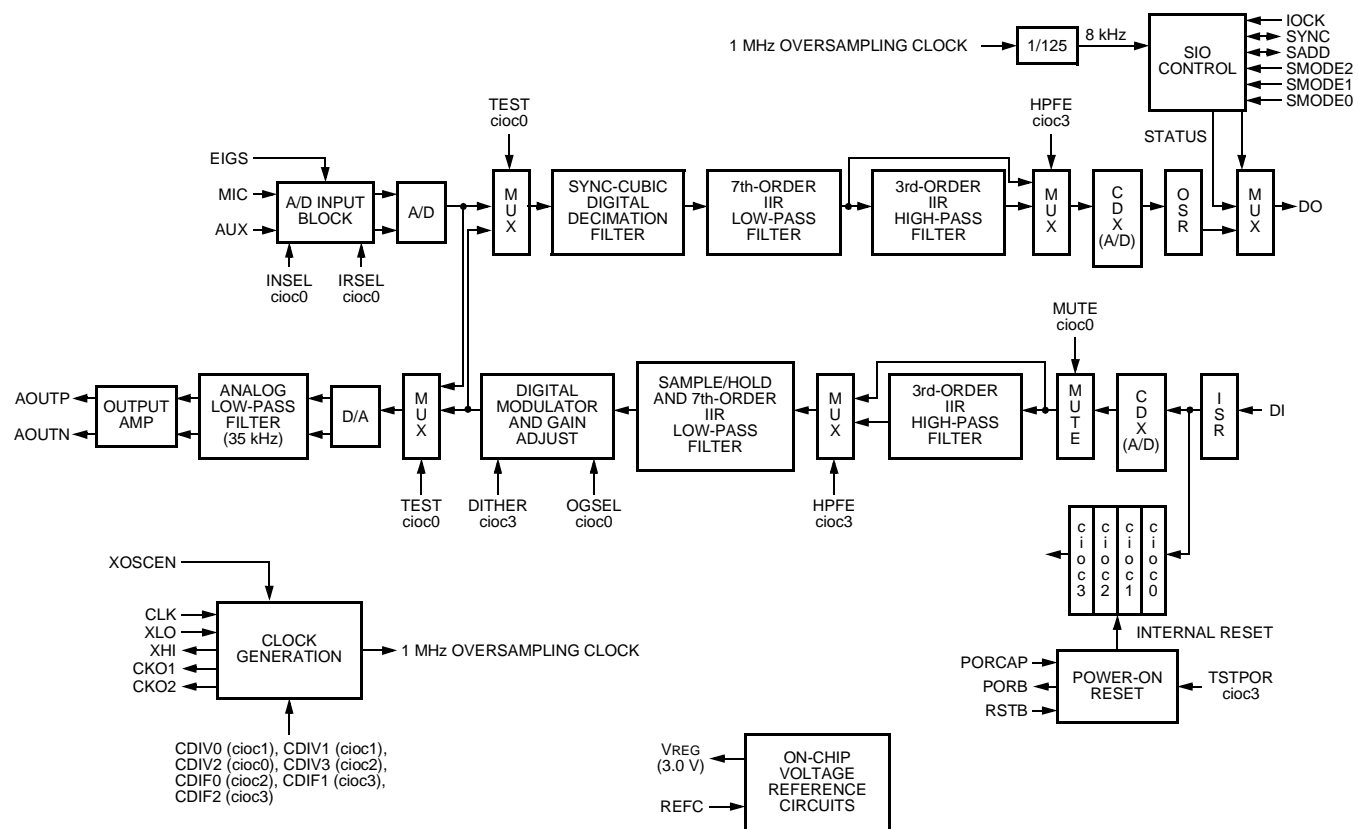

5-7559 (F)

Figure 3. CSP1027 Block Diagram

4 Architectural Information (continued)

4.1 Overview

The CSP1027 is a complete analog-to-digital and digital-to-analog acquisition and conversion system (see Figure 3 on page 5) that band limits and encodes analog input signals into 16-bit PCM, and takes 16-bit PCM inputs and reconstructs and filters the resultant analog output signal. The selectable A/D input circuits, programmable sample rates, and digital filter options allow the user to optimize the codec configuration for either speech coding or voice band data communications. The on-chip digital filters meet the ITU-T G.712 voice band frequency response and signal to distortion plus noise specifications and are suitable for IS-54, GSM, and JDC digital cellular applications. In addition, the small supply current drain, when powered down, extends battery life in mobile communication applications.

The CSP1027 is intended for both voice band voice and data communication systems. As a result, this codec has a variety of features not found in standard voice band codecs:

- 3.0 V regulated power supply for a condenser microphone.
- Microphone preamplifier with programmable input ranges.
- Mute control of D/A output.
- Programmable output gain in 3 dB increments.
- Output speaker driver.
- Programmable master clock divider to set A/D and D/A conversion rate.
- Testability loopback mode.
- High-quality dither scheme to eliminate idle channel tones.

4.2 Description of Signal Paths

4.2.1 Sampling Frequency

The oversampling ratio of the codec is 125:1; this is the ratio of the frequency of the oversampling clock to the frequency of the sampling clock. Most speech applications specify a sampling frequency of 8 kHz, yielding an oversampling frequency of 8 kHz x 125 = 1.0 MHz. The codec will operate at sampling frequencies up to 24 kHz, with the frequency response of the digital filters being changed proportionally. For this architectural description, the sampling frequency, f_s , is assumed to be 8 kHz, with an oversampling frequency, f_{os} , of 1 MHz, unless otherwise stated.

4.2.2 Analog-to-Digital Path

The analog-to-digital (A/D) conversion signal path (see Figure 3 on page 5) begins with the analog input driving the input block. The signal from the input block is then encoded by a second-order Δ - Σ modulator A/D. The bulk of the antialiasing filtering is done in the digital domain in two stages following the Δ - Σ modulator to give a 16-bit result. The blocks will next be covered in more detail.

4.2.3 Analog Input Block

The A/D input block operates in two modes: when the external input gain select (EIGS) pin is low or left unconnected, the input goes through a preamplifier and is band limited by a second-order 30 kHz low-pass antialiasing filter (see Figure 4 on page 7). When EIGS is high, external resistors, R_{in} and R_{fb} , are used to set the gain of an inverting amplifier (see Figure 5 on page 7). These resistors, in combination with C_{in} and C_{fb} , create a bandpass antialiasing filter. Note that EIGS is a digital pin whose input levels are relative to digital power and ground (V_{DD} and V_{SS}).

4.2.4 A/D Modulator and Digital Filters

A second-order Δ - Σ modulator quantizes the analog signal to 1 bit (see Figure 3 on page 5). At the same time, the resulting quantization noise is shaped such that most of this noise lies outside of the baseband. The modulator output is then digitally low-pass filtered to remove the out-of-band quantization noise. After this filtering, the output samples are decimated down to the output sampling frequency. In the CSP1027, the filtering and decimation are completed in two stages. The first-stage low-pass filter shapes the modulator output according to the sinc-cubic transfer function:

$$H(z) = \left[\frac{1}{25} \times \frac{(1 - z^{-25})}{(1 - z^{-1})} \right]^3$$

The output sampling frequency of the sinc-cubic filter is reduced by a factor of 25 from 1 MHz to 40 kHz. The sinc-cubic filter places nulls in the frequency response at multiples of 40 kHz, and removes most of the quantization noise above 20 kHz so that very little energy is aliased as a result of the decimation.

The sinc-cubic filter output is then processed by a seventh-order IIR digital low-pass filter. This filter removes the out-of-band quantization noise between 3.4 kHz and 20 kHz, compensates for the passband droop caused by the sinc-cubic decimator, and decimates the sampling frequency by a factor of five from 40 kHz to 8 kHz.

4 Architectural Information (continued)

Following the low-pass filtering and decimation to 8 kHz, the 16-bit two's complement PCM can go directly to the output register, **cdx(A/D)**, or go to a third-order IIR digital high-pass filter and then to the output register. The -3 dB corner frequency of the high-pass filter is approximately 270 Hz. This filter exceeds the VSELP preprocessing requirements of IS-54 for attenuation of 60 Hz and 120 Hz signals. The high-pass filter is selected by writing the HPFE field in the **cioc3** register (see Table 10 on page 29). The default value upon reset is the high-pass filter enabled (HPFE = 0).

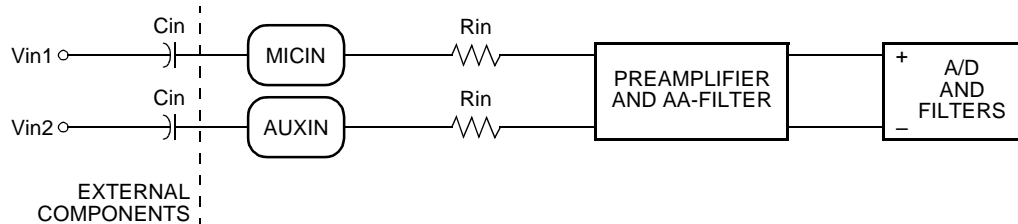

5-7592 (F)

Figure 4. CSP1027 A/D Path When in the Preamp Mode (EIGS = 0)

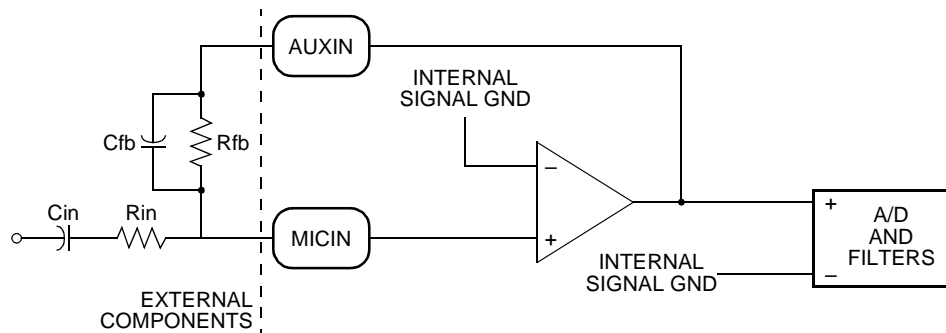

5-7593 (F)

Figure 5. CSP1027 A/D Path in the External Gain Select Mode (EIGS = 1)

4.2.5 A/D Path Frequency Response

The composite digital filters (decimator, LPF, and HPF) meet the ITU-T G.712 voice band frequency response specifications and are suitable for IS-54, JDC, and GSM digital cellular applications. Figures 6 through 9 show the A/D and D/A frequency response without the optional high-pass filter (HPF). Figures 10 and 11 show the group delay characteristics of the A/D and D/A without the high-pass filter. Figures 12 and 13 show the frequency response of the high-pass filter. Figures 14 and 15 show the group delay characteristics of the high-pass filter. In all figures, the frequency is normalized to the sampling frequency f_s (i.e., frequency/ f_s). To get the actual frequency, multiply the normalized frequency by f_s . The absolute delay and delay distortion have been normalized to the sampling period $1/f_s$ (i.e., delay $\times f_s$).

To obtain the actual delay, divide the normalized delay by f_s . The templates shown in Figures 7 through 9, 11 through 13, and 15 correspond to the limits in the ITU-T G.712 specification where $f_s = 8.0$ kHz.

4.2.6 PCM Saturation Versus Analog Input Levels

16-bit two's complement saturation is employed to prevent wraparound during input overload conditions. The saturation is hard-limiting:

0x7fff = maximum positive level

0x8000 = minimum negative level

The analog levels that correspond to the saturation levels for the three input modes are outlined in Table 14 on page 51.

4 Architectural Information (continued)

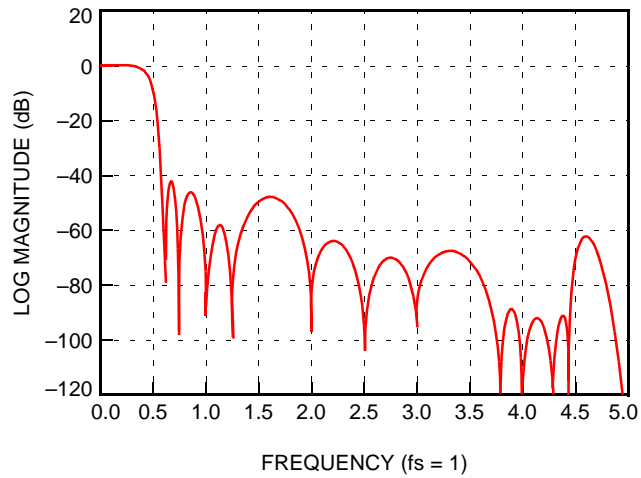

5-7594 (F)

Figure 6. A/D or D/A Path Frequency Response Over 5.0 fs Bandwidth (HPF Disabled)

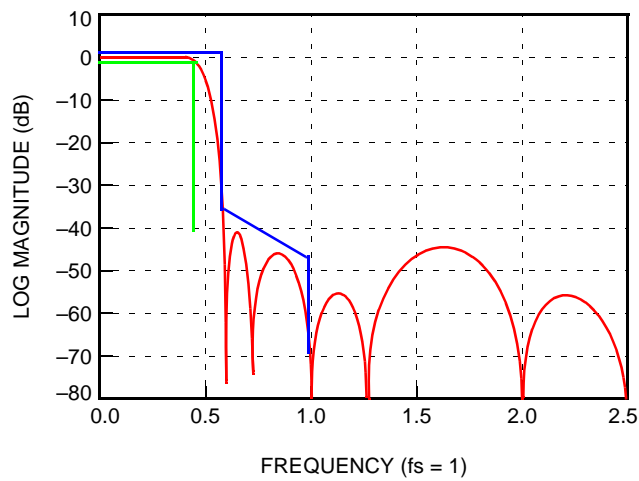

5-7595 (F)

Figure 7. A/D or D/A Path Frequency Response Over 2.5 fs Bandwidth (HPF Disabled)

4 Architectural Information (continued)

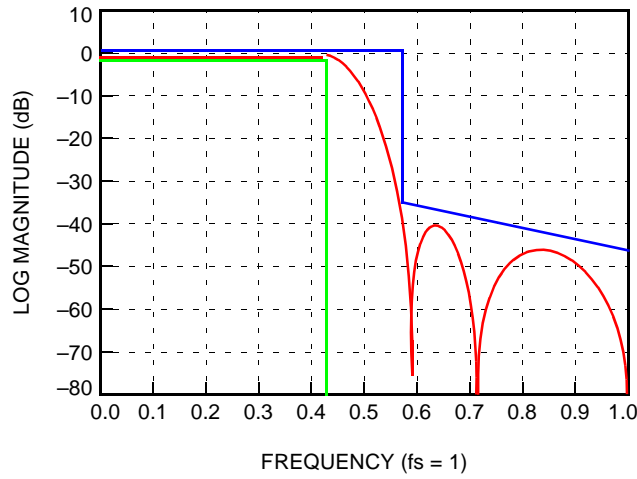

5-7596 (F)

Figure 8. A/D or D/A Path Frequency Response Over f_s Bandwidth (HPF Disabled)

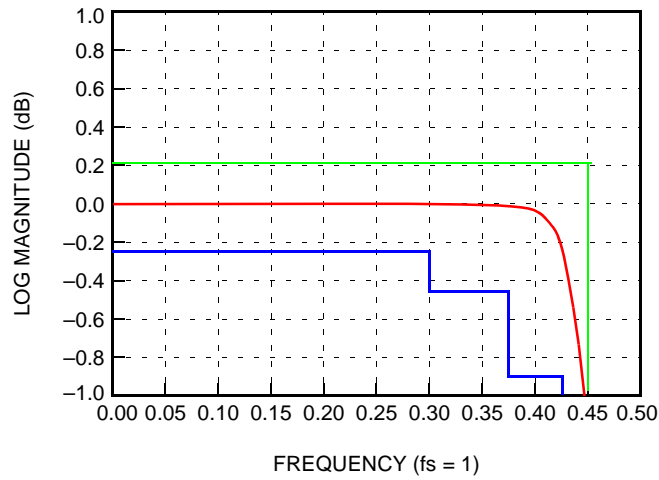

5-7597 (F)

Figure 9. A/D or D/A Path Frequency Response Over $0.5 f_s$ Bandwidth (HPF Disabled)

4 Architectural Information (continued)

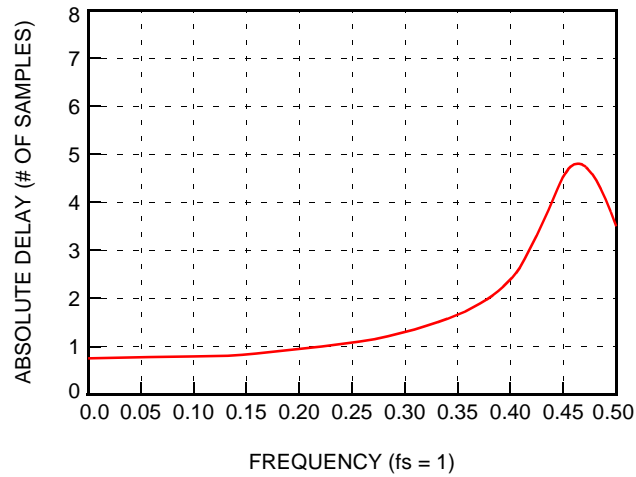

5-7598 (F)

Figure 10. A/D or D/A Path Absolute Group Delay (HPF Disabled)

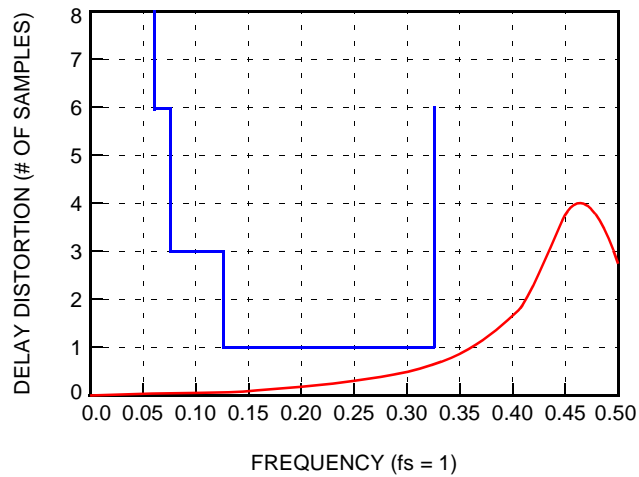

5-7599 (F)

Figure 11. A/D or D/A Path Group Delay Distortion (HPF Disabled)

4 Architectural Information (continued)

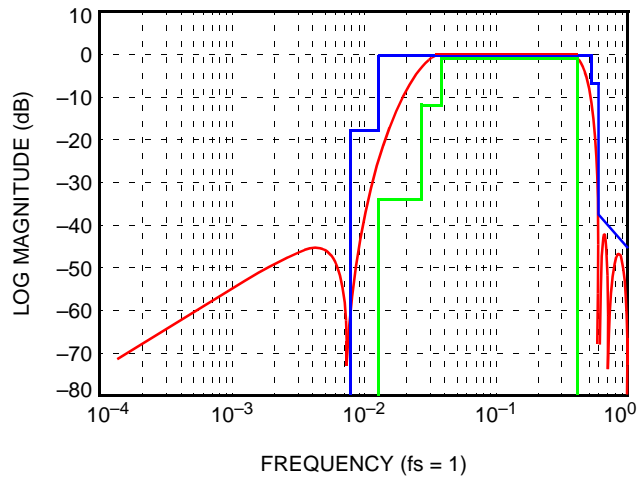

5-7600 (F)

Figure 12. A/D or D/A Path Frequency Response Over f_s Bandwidth (HPF Enabled)

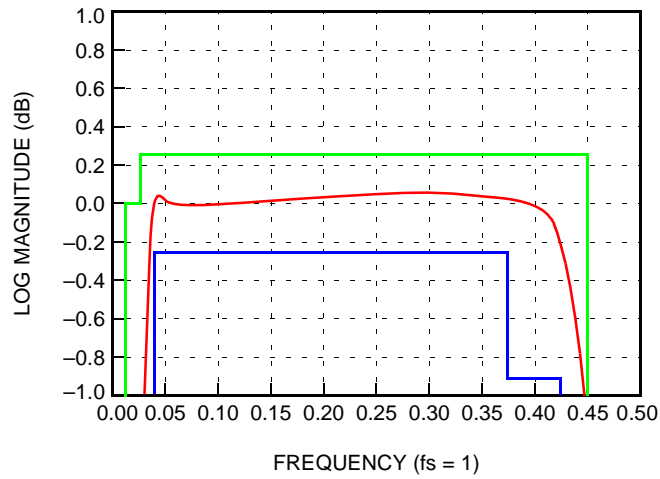

5-7601 (F)

Figure 13. A/D or D/A Path Frequency Response Over $0.5 f_s$ Bandwidth (HPF Enabled)

4 Architectural Information (continued)

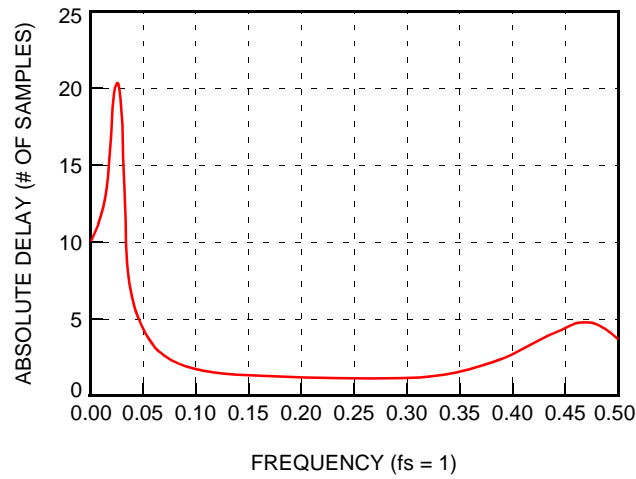

5-7602 (F)

Figure 14. A/D or D/A Path Absolute Group Delay (HPF Enabled)

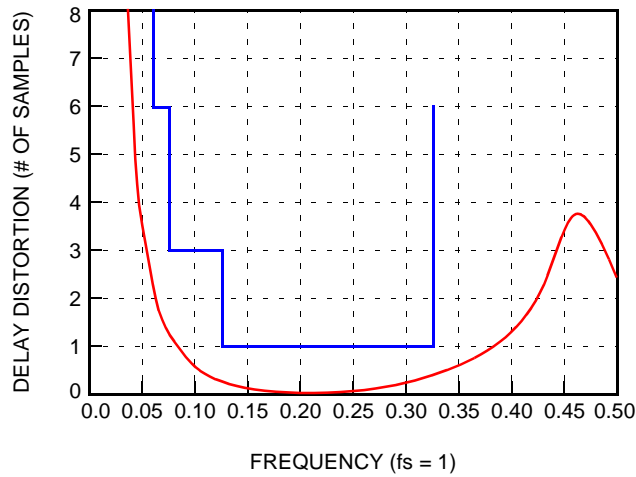

5-7603 (F)

Figure 15. A/D or D/A Path Group Delay Distortion (HPF Enabled)

4 Architectural Information (continued)

4.2.7 Digital-to-Analog Path

Starting at the bottom right of Figure 3 on page 5, the Δ - Σ D/A conversion process begins with a 16-bit two's complement PCM signal read from the DI serial input. The PCM is interpolated up to 1 MHz in two stages and low-pass filtered at each stage to attenuate 8 kHz images.

The PCM input is latched into the **cdx(D/A)** register at a nominal word rate of 8 kHz. The signal is then optionally high-pass filtered. This filter has the same transfer function as the A/D high-pass filter.

A digital sample-and-hold increases the word rate by a factor of 5 from 8 kHz to 40 kHz. The seventh-order IIR digital low-pass filter then removes the spectral images between 4 kHz and 20 kHz and predistorts the passband to compensate for the filtering done during the interpolation up to the 1 MHz word rate. The transfer function of this low-pass filter is the same as the one employed in the A/D converter.

The output of the low-pass filter feeds a programmable gain adjustment block that serves as a volume control. The gain can be changed in 3 dB increments from 0 dB to -45 dB. The attenuation level is set by writing the OGSEL field in the **cioc0** register (see Table 7 on page 26).

The digital modulator block further increases the word rate by a factor of 25 from 40 kHz to 1 MHz. Through quantization and noise shaping, the digital Δ - Σ modulator creates 1-bit output words at 1 MHz.

The modulator 1-bit output drives a structure combining a 1-bit D/A converter and a second-order switched-capacitor filter having a cutoff frequency of 8 kHz (based on a 1 MHz clock). This is all shown as the D/A block in Figure 3 on page 5.

This is followed by a second-order active Chebychev filter having a cutoff frequency of 35 kHz.

The passband ripple of the analog filters is small enough such that they have virtually no effect on the passband response.

The output amplifier buffers the analog filter output.

The frequency responses of the A/D and D/A paths are essentially the same. See Figures 6 through 15 for the magnitude and delay responses versus frequency.

4.3 Programmable Features

4.3.1 Active/Inactive Modes

The CSP1027 has active and inactive modes of operation which are selected by the ACTIVE field in the **cioc0** register (see Table 7 on page 26). The default value upon reset and powerup is ACTIVE = 0 (i.e., inactive). In the inactive mode, the codec clocks are disabled, data transfers by the codec are disabled, and analog bias currents are shut off. This state is useful in battery-powered applications when prolonged periods of inactivity are expected. It takes approximately 600 ms for the codec to reach full steady-state performance in going from inactive to active. This is primarily due to the charging of the large external capacitors, CREF and CREG. However, the codec is functionally useful after 100 ms.

4.3.2 Input Select

When the A/D preamplifier is selected (EIGS = 0), the INSEL field of **cioc0** (see Table 7 on page 26) switches the preamp input between the MICIN and AUXIN inputs. When external gain select is used (EIGS = 1), the INSEL field has no effect.

4.3.3 A/D Input Ranges

When the preamplifier is used (EIGS = 0), the IRSEL field of the **cioc0** register (see Table 7 on page 26) selects the 500 mVp range when IRSEL = 0 and the 160 mVp range when IRSEL = 1. IRSEL has no effect when the external gain select mode is used (EIGS = 1).

When EIGS = 1, the inverting amplifier of Figure 5 on page 7 replaces the preamplifier. The input range in this mode is the following:

$$V_{\text{FULL-SCALE}} = \frac{R_{\text{in}}}{R_{\text{fb}}} \times 1.578 \text{ Vp}$$

4.3.4 Output Mute Function

The D/A converter output can be selectively muted with the MUTE field in the **cioc0** register (see Table 7 on page 26). The default value upon reset is muted (MUTE = 0). The mute function is implemented (Figure 3 on page 5) internally by a MUX following the D/A input. Placing the mute function here causes the signal at the analog output to gradually decay/rise over approximately 1 ms upon muting/unmuting. This effect is due to the impulse response and group delay of the digital filters. This implementation will reduce any potentially undesirable transient effects such as pops, when the D/A is muted.

4 Architectural Information (continued)

4.3.5 Output Gains

The D/A converter output can be programmed in 3 dB increments with the OGSEL field in the **cioc0** register (see Table 7 on page 26) to serve as a volume control.

4.3.6 Loopback Mode

The codec has a programmable loopback mode, represented by the TEST field in the **cioc0** register, (see Table 7 on page 26). As shown in Figure 3 on page 5, when TEST = 0, the codec is in its normal mode of operation. When TEST = 1, the loopback mode is activated. In loopback mode, the 1-bit PDM output signal from the analog modulator is received by the analog demodulator. At the same time, the 1-bit signal output from the digital modulator is received by the sinc-cubic filter in the A/D. This results in the analog input being looped back to the analog output through the A/D and D/A, and the digital input being looped back to the digital output through the digital filters. The loopback mode can be useful for evaluating analog performance of the codec in the target system without going through the digital filters. This mode is also useful for evaluating the response of the digital filters or in evaluating the read/write functions of the **codec** and **cdx** registers without having to provide an analog input to the A/D.

4.3.7 High-Pass Filter Select

The high-pass filter in the A/D and D/A can be enabled or disabled with the HPFE field in the **cioc3** register (see Table 10 on page 29).

4.3.8 Dither

A dithering scheme is employed in the CSP1027 which decorrelates the periodic quantization noise of the D/A modulator to make it white noise.

Δ - Σ converters are popular due to their high tolerance to component mismatch present in integrated circuit fabrication processes. However, Δ - Σ converters may suffer from periodic noise and spurious tone generation (in-band and out-of-band) due to the coarse quantization and feedback of the Δ - Σ modulator. Although this periodic noise may exist at very low levels (for example, at about -90 dBm), it may be very objectionable to the listener while having virtually no impact on the resolution of the converter. The CSP1027 D/A uses a robust dithering scheme which eliminates any potential problems due to this phenomenon.

The DITHER field in the **cioc3** register (see Table 10 on page 29) disables this feature. The default value upon reset is DITHER = 0 (i.e., enabled). When the DITHER is disabled, the signal-to-noise ratio will generally be about 2 dB higher. The DITHER should be enabled if the CSP1027 is used in an audio application, i.e., where this device interfaces to an audio transducer. If the CSP1027 is used in an application other than audio, such as data communications, the DITHER can be disabled if so desired.

4.4 Power-On Reset

4.4.1 Internal

The CSP1027 has a power-on reset circuit that is ORed internally with the inversion of the reset pin, RSTB, to form the internal reset (see Figure 16 on page 15). The power-on reset circuit's inverted output is also an output pin, PORB. The PORB can be used to provide power-on reset to the system.

The power-on reset circuit is composed of two pulse-generating elements, its output being the OR of the two. One element is entirely internal and generates a power-on pulse of 1.5 ms to 7.0 ms. The second element is composed of an input pin, PORCAP, a resistor connected between PORCAP and VDD, and an inverting input buffer. The user selects the capacitor value to connect between PORCAP and ground that will generate a power-on pulse of desired width. The pin PORCAP allows the user to lengthen the power-on reset pulse to a width greater than the internal power-on element provides. The nominal value of the resistor is 155 k Ω , and the threshold of the inverting input buffer is 0.6 x VDD. The formula that relates the power-on reset pulse delay to the PORCAP capacitor is as follows:

$$T_D = -R \times C \times \log_e (1 - 0.6)$$

$$T_D = 0.9163 \times R \times C$$

Hence, to generate a 14.2 ms power-on reset pulse, one would use a 0.1 μ F capacitor connected between PORCAP and VSS.

An internal power-on pulse can be initiated after power-on by writing a one to the TSTPOR field in the **cioc3** register (see Table 10 on page 29). This causes the internal power-on pulse of 1.5 ms to 7.0 ms to be generated. The pulse resets the device and appears on the PORB output pin.

4 Architectural Information (continued)

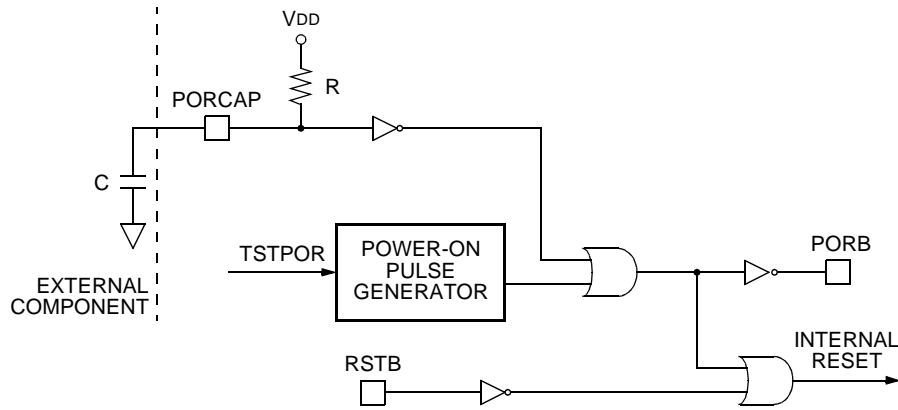

5-7604 (F)

Figure 16. Power-On Reset Diagram

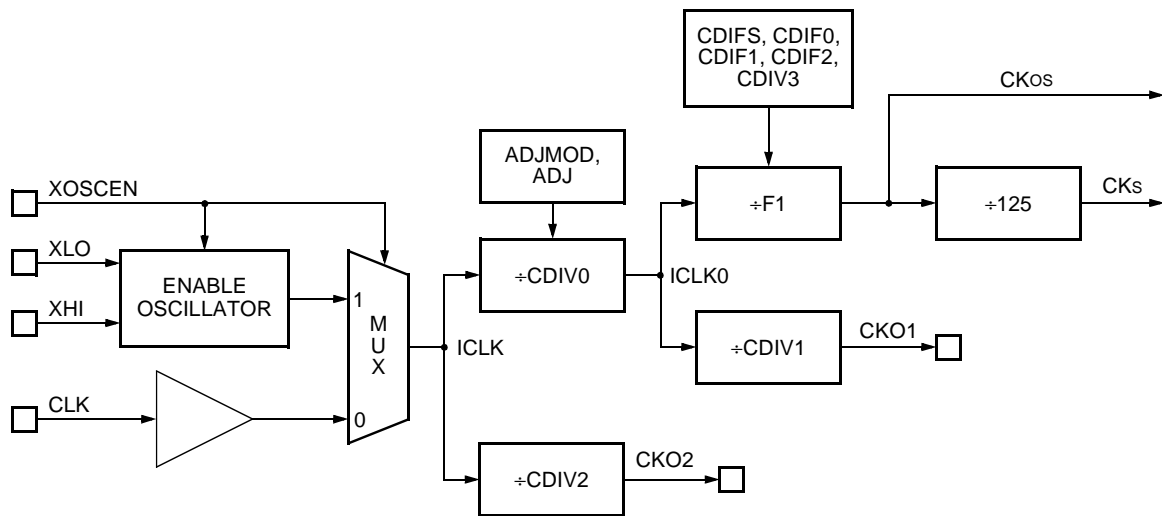

5-7560 (F)

Figure 17. Clock Generation

4 Architectural Information (continued)

4.5 Clock Generation

Figure 17 on page 15 shows the clock generation and distribution for the CSP1027. The programmable dividers can customize the codec sample and master clock rates for a variety of applications in addition to standard 8 kHz sampling, while allowing a range of values for the crystal-controlled input clock. In Figure 17 on page 15, XOSCEN is a chip input to enable the crystal oscillator circuit. XLO and XHI are the two leads for the crystal. CLK is the chip clock input if the crystal is not used. CKs is the internal codec sample clock, typically 8 kHz. CKos is the internal codec oversampled clock, typically 1 MHz. CKO1 and CKO2 are general-purpose clocks brought out to chip pins. CDIV1 and CDIV2 are programmable dividers with a range from 1 to 31. CDIV0 is programmed to be 1 or 2, but extra clock pulses can be added or subtracted at the output for one period of time following a write to the control register **cioc1**. This one-time increase or decrease in the number of clocks is programmed by ADJMOD and ADJ and causes a phase shift in the CKO1 and CKs output. F1 is an integral or a fractional divider controlled by the five programmable coefficients shown connected to it. With the fractional divide, the period of CKOs will vary, but the period of CKs will be constant.

The following discussion begins with the crystal oscillator and is followed by a detailed description of each divisor block. Section 7.5 on page 45 provides some examples of how to program the clocks.

4.5.1 Crystal Oscillator

The CSP1027 has a selectable on-chip clock oscillator. A logic 1 on the XOSCEN pin enables the crystal oscillator. A logic 0 disables the oscillator, powers it down, and selects the input buffer connected to the CLK pin.

To use the oscillator, select a 20 MHz to 30 MHz fundamental-mode crystal with a series resistance less than 60 Ω and a mutual capacitance less than 7.0 pF. Connect the crystal between the XLO and XHI pins, and add 10 pF capacitors between XLO and ground, and XHI and ground. The XOSCEN pin enables and disables the crystal oscillator. See the application information on optimizing the oscillator performance.

4.5.2 Clock Divider 2

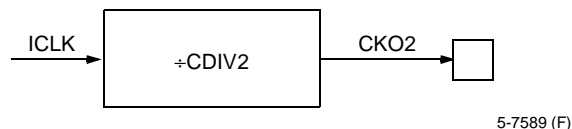

Figure 18. Clock Divider 2

The CDIV2 field in **cioc0** (see Table 7 on page 26) sets the clock divider that generates the output clock, CKO2. The clock output is a general-purpose clock that can be used to clock external logic or processors. CDIV2 ranges from 1 to 31, with 0 holding the output low. RSTB going low sets CDIV2 to $\div 16$. CKO2 is active while RSTB is low and synchronized by RSTB going high.

4.5.3 Clock Divider 0

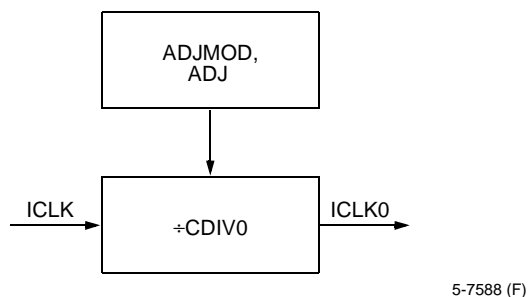

Figure 19. Clock Divider 0

The CDIV0 field in **cioc1** (see Table 8 on page 27) sets the clock divider that generates the internal clock 0 (ICLK0) to either divide by one or divide by two. The ADJMOD and ADJ fields in **cioc1** are used to adjust the phase of ICLK0 by increasing or decreasing the rate of ICLK0 for a burst of pulses, one time only. This event occurs each time control register **cioc1** is written with nonzero values of ADJ. For example, let CDIV0 be set to $\div 2$, ADJ to seven, and ADJMOD to one (advance). After this word is written to the **cioc1** register, seven ICLK0 pulses will occur at the same rate as ICLK, not divided by two. These seven clock pulses shift the phase of CKOs, CKs, and CKO1 earlier, thus advancing these clocks. If ADJMOD is set to zero (retard), the $\div 2$ becomes a $\div 3$ for seven pulses of ICLK0. The CDIV0 clock divider is temporarily changed internally so that it divides by one greater, to retard the clocks, or one less, to advance the clocks, for the specified number of ICLK0 cycles. Note that the CDIV0 clock divider must be set to divide by two in order to advance and retard the clocks. If CDIV0 clock divider is set to divide by 1, one can only retard the clocks.

4 Architectural Information (continued)

CDIV0 has values of 1 or 2, ADJMOD is 0 or 1, and ADJMOD ranges from 1 to 127, with 0 selecting no clock adjust. RSTB going low sets CDIV0 to ÷2. ICLK0 is active while RSTB is low and synchronized by RSTB going high.

4.5.4 Clock Divider 1

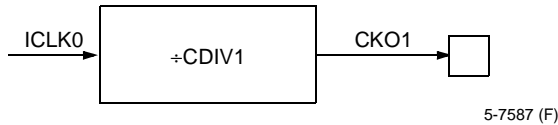

Figure 20. Clock Divider 1

The CDIV1 field in **cioc1** (see Table 8 on page 27) sets a clock divider that generates the CKO1 output clock. This general-purpose clock output can be used for clocking another codec in the system, such as the CSP1084. The ability to phase adjust the output clock and the codec sampling clock simultaneously is an important feature. CDIV1 ranges from 1 to 31, with 0 disabling the output. RSTB going low sets CDIV1 to ÷16. CKO1 is active while RSTB is low and synchronized by RSTB going high.

4.5.5 Sampling Clocks Generation

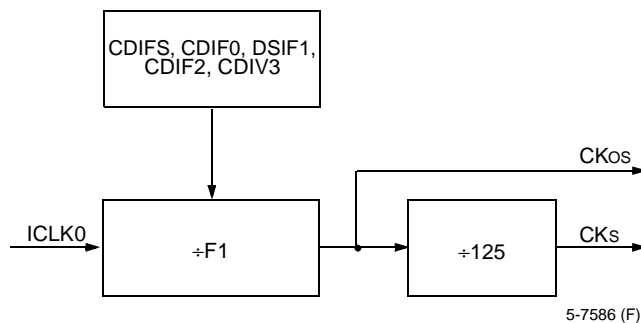

Figure 21. Sampling Clocks Generation

The oversampling codec clock CKOs, typically 1 MHz, is used in the front sections of the A/D and the back sections of the D/A. The lower-frequency codec clock, CKs, typically 8 kHz, is the sample clock at the output of the A/D and the input to the D/A. The sampling clock frequency, f_s , is the oversampling clock frequency, f_{OS} , divided by 125 (the fixed oversampling ratio). The divide by 125 must remain fixed, since it is constrained by the architecture of the codec digital filters. Many systems, however, have fixed high-frequency clocks and fixed sampling clocks, so it is necessary to have a great deal of flexibility in the creation of the codec clock CKs.

The CSP1027 solves this problem in a unique way, by providing a programmable, fractional divider, F1.

F1 is the programmable ratio between ICLK0 and CKOs. The equation for F1 is:

$$F1 = M + \left(S \times \frac{N}{125} \right)$$

where $3 \leq M \leq 64$, $0 \leq N \leq 62$, and $S = \{1, -1\}$;

or $M = 2$, $0 \leq N \leq 62$, and $S = 1$;

or $M = 1$, $N = 0$, and $S = 1$.

M is encoded by CDIV3 (see Table 3 on page 18), N is encoded by CDIF0, CDIF1, and CDIF2 (see Table 5 on page 19), and S is encoded by CDIFS (see Table 4 on page 18).

CKs is generated by dividing CKOs by 125. The frequency of CKs can be described by:

$$f_s = f_{OS} \div 125 = \left[f_{ICLK0} \div \left(M + S \times \frac{N}{125} \right) \right] \div 125$$

Note that when $N = 0$, ICLK0 is simply divided by the integer M to create the oversampling clock, CKOs. This is the preferred method for generating the sampling clock. If $N \neq 0$, the fractional division results in an oversampling clock, CKOs, whose period varies with time such that the average period is the desired fraction. This variation in the oversampling clock period is minimized by the clock generator but can cause distortion in the codec. Because the denominator of the fraction is fixed at 125, the period of the sampling clock, CKs, will be an integer multiple of the period of the internal clock, ICLK0, and will not vary. This is more clearly shown by the following equation:

$$\frac{f_{ICLK0}}{f_s} = (125 \times M) + (S \times N)$$

The expanded equation below explains what is happening in the time domain:

$$\frac{1}{f_s} = \left[(125 - N) \times \frac{M}{f_{ICLK0}} \right] + \left[N \times \frac{(M + S)}{f_{ICLK0}} \right]$$

During each sampling period, $\frac{1}{f_s}$, there are $(125 - N)$

oversampling clock cycles of period $\frac{M}{f_{ICLK0}}$ and N

oversampling clock cycles of period $\frac{(M + S)}{f_{ICLK0}}$. The N

oversampling clock cycles are evenly distributed among the $(125 - N)$ oversampling clock cycles to minimize the distortion due to oversampling clock cycles of differing period. The values for CDIF[0–2] in Table 5 on page 19 have been selected to achieve the even distribution.

4 Architectural Information (continued)

The procedure for selecting M, S, and N is illustrated in Section 7.5 on page 45. The ranges for the programmable dividers are summarized in Table 2.

Table 2. Programmable Divider Summary

Clock Ratio	ICLK/ICLK0	ICLK0/CKos	ICLK0/CKs	ICLK/CKO2	ICLK0/CKO1
Variable Name	CDIV0	$M \pm \frac{N}{125}$	$125M \pm N$	CDIV2	CDIV1
Range of Values	1, 2	1, 2 to 64.496	125, 250 to 8062	Off, 1 to 31	Off, 1 to 31
Encoding	0, 1	See Tables 3 through 5.	See Tables 3 through 5.	0 to 31	0 to 31

Table 3. CDIV3 Value for Each M

M	CDIV3
1	00 0001
2	00 0010
.	.
.	.
62	11 1110
63	11 1111
64	00 0000

Table 4. CDIFS Value for Each S

S	CDIFS
+1	0
-1	1

4 Architectural Information (continued)

Table 5. CDIF0, CDIF1, CDIF2 Values for Each N

N	CDIF0	CDIF1	CDIF2	N	CDIF0	CDIF1	CDIF2
0	00 0000	00 0000	0 0000	32	00 0100	10 1000	0 0010
1	11 1111	00 0000	0 0000	33	00 0100	10 0100	0 0010
2	11 1101	00 0010	0 0000	34	00 0011	00 0010	1 0010
3	10 1001	00 0010	0 0000	35	00 0011	00 0010	1 0100
4	01 1111	00 0000	0 0000	36	00 0011	00 0010	0 0100
5	01 1001	00 0000	0 0000	37	00 0011	00 0011	1 0010
6	01 0101	10 0110	0 0000	38	00 0011	00 0011	0 0010
7	01 0010	10 0100	0 0000	39	00 0011	00 0100	0 0010
8	00 1111	00 0010	0 0000	40	00 0011	00 0111	0 0000
9	00 1110	10 0101	0 0000	41	00 0011	00 1110	0 0000
10	00 1100	00 0010	0 0000	42	00 0011	11 0110	0 0000
11	00 1011	00 0010	0 0010	43	00 0011	10 1001	0 0000
12	00 1010	00 0010	0 0010	44	00 0011	10 0110	0 0000
13	00 1001	00 0010	1 0010	45	00 0011	10 0100	0 0010
14	00 1001	10 0111	0 0010	46	00 0011	10 0011	0 0010
15	00 1000	00 0011	0 0000	47	00 0010	00 0010	1 0010
16	00 1000	10 0100	0 0010	48	00 0010	00 0010	1 0011
17	00 0111	00 0011	0 0000	49	00 0010	00 0010	1 0101
18	00 0111	10 1001	0 0010	50	00 0010	00 0010	0 0000
19	00 0110	00 0010	1 0011	51	00 0010	00 0010	0 0011
20	00 0110	00 0011	0 0010	52	00 0010	00 0010	0 0010
21	00 0110	10 1011	0 0000	53	00 0010	00 0011	1 0011
22	00 0101	00 0010	1 0010	54	00 0010	00 0011	0 0011
23	00 0101	00 0010	0 0010	55	00 0010	00 0011	0 0010
24	00 0101	00 0100	0 0010	56	00 0010	00 0100	0 0010
25	00 0101	00 0000	0 0000	57	00 0010	00 0101	0 0000
26	00 0101	10 0100	0 0010	58	00 0010	00 0110	0 0000
27	00 0100	00 0010	1 0011	59	00 0010	00 0111	0 0010
28	00 0100	00 0010	0 0011	60	00 0010	00 1010	0 0010
29	00 0100	00 0011	0 0000	61	00 0010	00 1111	0 0010
30	00 0100	00 0101	0 0010	62	00 0010	00 0000	0 0000
31	00 0100	00 0000	0 0000				

4 Architectural Information (continued)

4.6 Serial I/O Configurations

4.6.1 Codec Data Transfer

When the codec is active, $ACTIVE = 1$ (see Table 7 on page 26), it loads data into the **cdx(A/D)** and empties data from the **cdx(D/A)** register (see Figure 3 on page 5) at the sampling frequency, f_s (which is 8 kHz based on a 1 MHz oversampling frequency). The codec data transfers occur independent of the serial input/output data transfers described below. The data is double buffered, allowing the codec to transfer data to or from the **cdx** while the serial I/O is shifting data into or out of the shift registers (**isr** and **osr**). When the codec is set to inactive, $ACTIVE = 0$, there are no codec data transfers to the **cdx(A/D)** or from the **cdx(D/A)**.

The internal STATUS flag is set high when **cdx(A/D)** is loaded and **cdx(D/A)** is emptied. Loading data from the **cdx(A/D)** into the output shift register (**osr**) or loading data from the input shift register (**isr**) into the **cdx(D/A)** due to a serial I/O transaction, clears the internal STATUS flag. The internal STATUS flag can be observed on the data output (DO) pin in the passive mode and causes data transfers in the active and multiprocessor modes.

4.6.2 Codec Control Writes

The four control registers are written through the serial port. The serial address (SADD) selects between control and data transfers. Bits 15 and 14 of the control word being transferred select which control register, **cioc0**, **cioc1**, **cioc2**, or **cioc3**, is written (i.e., **cioc0**: Bit[15:14] = 00, **cioc1**: Bit[15:14] = 01, etc.).

4.6.3 Serial I/O Port Overview

The CSP1027 serial I/O unit is an asynchronous, full-duplex, double-buffered channel operating at up to 20 Mbps that easily interfaces with other Lucent fixed-point DSPs (i.e., DSP16A and DSP1610/1616/1617/1618) in a single or multiple DSP environment. Commercially available codecs and time-division multiplexed (TDM) channels can be interfaced to the CSP1027 device with little, if any, external logic.

The serial interface is a subset of the standard Lucent DSP serial I/O and is comprised of eight pins:

- A single passive serial input/output clock (IOCK).
- A combined input load, output load, and synchronization (SYNC).
- Serial data input (DI).
- Serial data output (DO).
- Serial address (SADD).
- Three serial mode select pins (SMODE[2:0]).

The CSP1027's serial I/O is different from the standard Lucent serial I/O in a number of ways:

- The SMODE[1:0] pins configure the serial I/O port into one of four possible ways: a passive SIO configuration, an active SIO configuration, and two multiprocessor SIO configurations.
- A fixed most significant bit (MSB) first data format.
- A fixed 16-bit data mode.
- The serial address (SADD) is an input during the passive and active SIO configurations to select between data and control SIO transfers. It is intended to be connected to the DSP's SADD pin, which is an output during passive and active SIO. Note that the DSP's SADD output is inverted and is composed of two 8-bit fields that are shifted out least significant bit (LSB) first.
- The multiprocessor mode time slots and serial addresses are restricted to two sets, one of which is selected based on the state of SMODE0.
- The SMODE2 pin should always be tied low for the serial I/O port to operate as described.
- The frequency of the serial I/O interface clock input IOCK (F_{IOCK}) must be greater than the frequency of the internal oversampling clock (F_{IOCK}).

4 Architectural Information (continued)

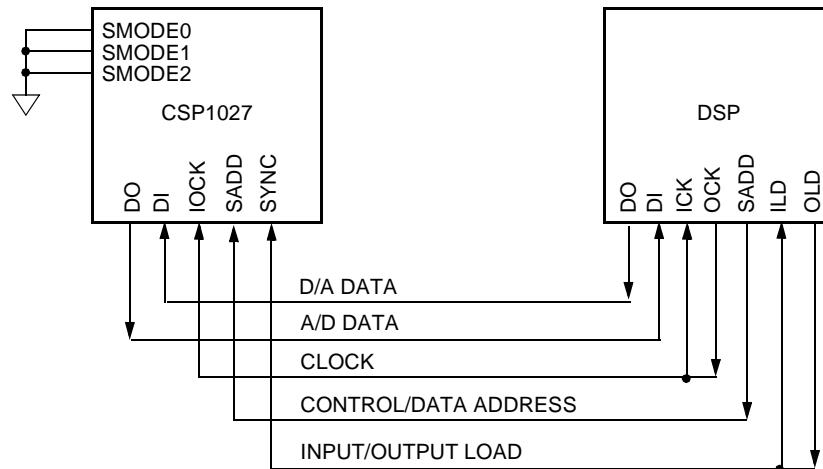

5-7590 (F)

Figure 22. Passive Communication and Connections

4.6.4 Passive I/O Configuration (SMODE[1:0] = 00)

The passive SIO configuration allows the user maximum flexibility in interfacing the CSP1027 to a variety of system hardware configurations. It requires that the user supply a serial input/output clock (IOCK) and perform data transfers at the sampling rate, f_s . Serial data transfers can be made to occur at the sampling rate by applying a clock that is synchronous with the codec clock, ICLK, to the SYNC pin or by polling the codec STATUS flag, which indicates that the **cdx(A/D)** register is full and the **cdx(D/A)** register is empty. The STATUS flag appears on DO when the SADD pin selects a control word.

Passive SIO is selected by setting both SMODE1 and SMODE0 low. The input/output clock (IOCK) is an input and the common input/output load, SYNC, (equivalent to a DSP16A's ILD and OLD tied together) is also an input. Serial data input (DI) is an input and serial data output, DO, is an output. The serial address (SADD) is an input, which determines if the transfer is to the control registers, **cioc**[0:3], or the data register, **cdx(D/A)**.

A high-to-low transition of SYNC pin signal, latched by the next rising edge of IOCK, initiates the start of an input and output transaction. If the CSP1027's output

buffer, **cdx(A/D)**, is full, it will be loaded into the output shift register (**osr**) and shifted out on the DO pin. The CSP1027 shifts in the data from the DI pin into its input shift register (**isr**). A serial transmit address on the SADD line is received simultaneously with data on the DI line. If SADD is high for the first 15 bits, corresponding to a zero serial transmit address, this causes the **isr** to be latched into **cdx(D/A)** after 16 bits have been shifted in. If SADD is low for any of the first 15 bits, corresponding to a nonzero transmit address, this causes the **isr** to be latched into **cioc**[0:3] and also changes the output data stream on DO to display the internal codec STATUS flag. If SADD is low for any clock cycle, while not involved in a serial transaction, the codec STATUS flag is displayed on the DO pin until the next data transfer.

An example of the passive SIO configuration is shown in Figure 22. The DSP supplies both the serial clock (IOCK) and the sampling synchronization signal to SYNC, or polls the internal codec STATUS flag to determine when a data transmission is needed. This configuration allows the user maximum flexibility in interfacing the CSP1027 to a variety of other system hardware configurations.

4 Architectural Information (continued)

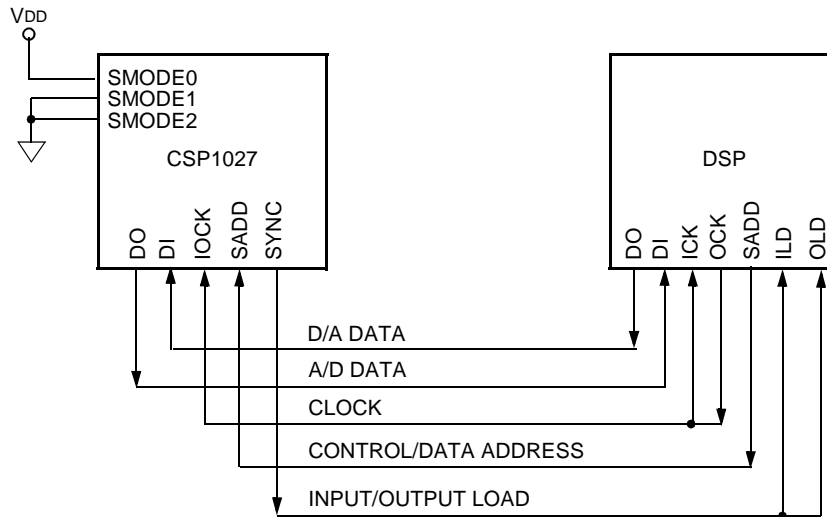

5-7591 (F)

Figure 23. Active Communication and Connections

4.6.5 Active I/O Configuration (SMODE[1:0] = 01)

The active SIO configuration causes the CSP1027 to generate an active input/output load (SYNC) to perform input/output transmissions when needed. The user supplies only a serial input/output clock (IOCK).

The active SIO is selected by setting SMODE1 low and SMODE0 high. The input/output clock (IOCK) is an input and the input/output load (SYNC) is an output. While the codec is inactive, ACTIVE = 0 (see Table 7 on page 26), SYNC generates serial I/O transfers at an $IOCK \div 16$ rate to allow loading the codec control registers, **cioc**[0:3]. While the codec is active, ACTIVE = 1 (see Table 7 on page 26), SYNC generates serial I/O transfers at the sampling rate, synchronized to the codec's emptying of the **cdx(D/A)** and loading of the **cdx(A/D)**. The serial address (SADD) functions as described previously for the passive SIO configuration, but with the SYNC pin being active and determining

data transfers, the need for polling the codec STATUS flag is eliminated. The serial address during the data stream still is used to determine whether data in the input shift register is latched into **cdx(D/A)** or **cioc**[0:3] at the end of the transaction. Note that **cioc**₀, with ACTIVE = 1, should be written last since this will change the rate of serial I/O transfers from $IOCK \div 16$ to the sampling rate.

An example of the active SIO configuration is shown in Figure 23. The DSP supplies the serial clock (IOCK) while the CSP1027 supplies the input/output load, SYNC. The serial address (SADD) is connected so that writing the DSP's **srta** register addresses the **cdx(D/A)** when **srta** = 0x0, or the **cioc**₀, **cioc**₁, **cioc**₂, **cioc**₃ when **srta** = 0x1. The DSP can activate the codec by writing the **cioc**₀ register in the CSP1027, and then letting its input buffer full flag (IBF) indicate when the CSP1027 has transferred data. This is the preferred interface for a single DSP and a CSP1027.

4 Architectural Information (continued)

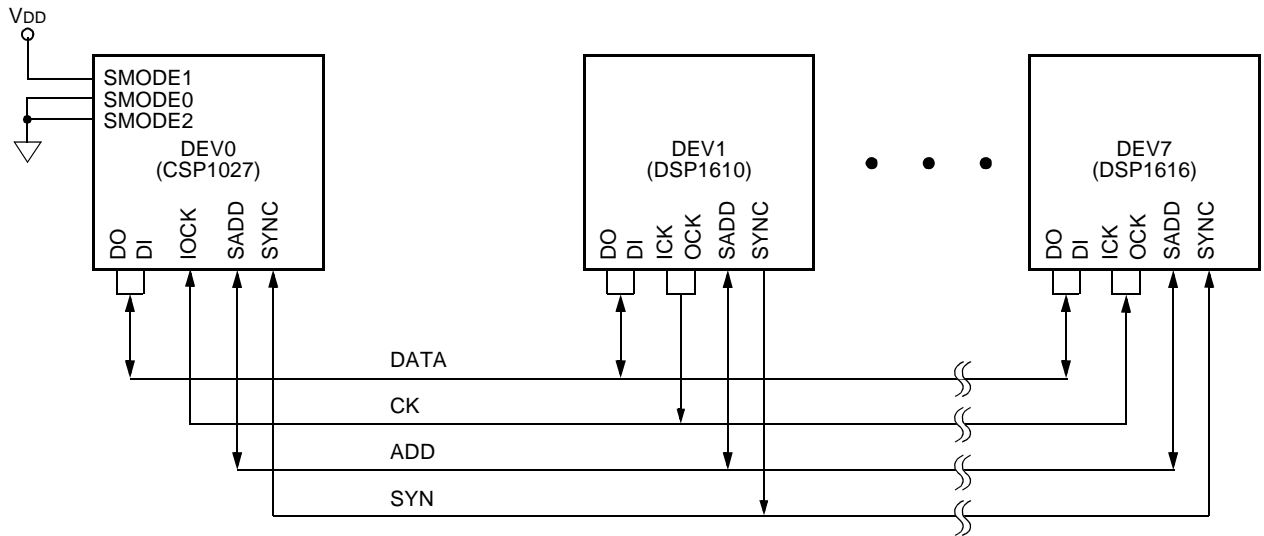

5-4181 (F).c

Figure 24. Multiprocessor Communication and Connections

4.6.6 Multiprocessor Configuration (SMODE[1:0] = 1X)

The CSP1027 serial I/O supports a multiprocessor mode that allows multiple devices to be connected together to provide data transmission between any of the individual devices. This mode requires no external hardware and uses a time-division multiplex (TDM) interface with eight time slots per frame.

Figure 24 shows an example of a multiprocessor system with multiple DSPs and a CSP1027. The following pins are connected together to form a four-wire bus:

- DI and DO from the CSP1027s and DSPs form a data line referred to as DATA.
- IOCK from the CSP1027s and ICK and OCK from the DSPs form a clock line referred to as CK.
- SADD from the CSP1027s and DSPs form an address line referred to as ADD.
- SYNC from the CSP1027s and DSPs form a synchronization line referred to as SYN.

Figure 25 on page 25 shows the time-slot allocation timing used in multiprocessor mode. One frame is defined as the time between SYN high-to-low transitions. Each frame is divided into eight time slots of 16 bits each. A

high-to-low transition of SYN defines the beginning of time slot 0 and also resynchronizes any devices which are operating on the multiprocessor bus with SYN as an input. Note that the DSP device which drives the multiprocessor bus during time slot 0 also drives the SYN line.

Each CSP1027 sends data in a time slot determined by its SMODE0 pin. Each DSP sends data in a time slot or time slots determined by its **tdms** register. Only one device can be assigned a particular time slot, and each of the eight time slots must be assigned to a device (note that one device can be assigned more than one time slot). These requirements must be met by the user's choice of CSP1027's SMODE0 connections and the DSP's **tdms** register contents. A CSP1027 is assigned to time slot 2 if SMODE0 is low or to time slot 5 if SMODE0 is high. This allows up to two CSP1027s to be placed on a multiprocessor bus.

The DSP input/output format can be configured to either most significant bit (MSB) first or least significant bit (LSB) first. The CSP1027 only supports MSB first format; hence, the DSPs connected on a multiprocessor bus must be using MSB first data format, configured in the **sioc** register, when transferring and receiving data and control words with the CSP1027.

4 Architectural Information (continued)

During each time slot (see Figure 26 on page 25), the device that is assigned to that time slot drives the ADD and DATA lines. If the assigned device's output buffer is full, it loads its output shift register and shifts the 16 bits of data, MSB first, out DO onto the DATA line. The 8-bit transmit address is inverted and shifted out, LSB first, onto the ADD line at the same time as the first 8 bits of data. The inverted 8-bit protocol information is then shifted out, LSB first, on the ADD line at the same time as the last 8 bits of data. The CSP1027's transmit address, AT[7:0], is determined by the SMODE0 pin (see Table 6 on page 25). The DSP's transmit address is determined by the **srta** register. The CSP1027's protocol information is always all zeros, which is inverted to appear as all ones on the ADD line. The DSP's protocol information is determined by the **saddx** register. If during a time slot the assigned device's output buffer is empty, then zeros are shifted out on the DATA line and zeros are shifted and inverted to become ones on the ADD line.

During each time slot, each device receives the data on the DATA line and inverts and receives the address and protocol information on the ADD line. Each device compares the transmitted 8-bit address with its receive address. If the transmitted address and the device's receive address have at least one occurrence of a one in the same bit location, the address matches and the device transfers the data from the input shift register to its input buffer. If the transmitted address and the receive address do not match, the data remains in the input shift register and is overwritten during the next time slot. The DSP's receive address is determined by its **srta** register. Each CSP1027 has two receive addresses, one for data and another for control, the values of these two addresses are determined by the SMODE0 pin (see Table 7 on page 26). When the data receive address matches, the input shift register is

loaded into the **cdx(D/A)** register. When the control receive address matches, the input shift register is loaded into one of the four **cioc** registers, based upon the two most significant bits of the 16-bit word. The CSP1027 ignores the protocol information.

Multiprocessor communication with a CSP1027 is intended to follow the sequence:

- The DSP writes the control registers, **cioc**[0:3], in the CSP1027 to configure the clock dividers and codec. The codec is also activated.
- The CSP1027's A/D fills the output buffer, **cdx(A/D)**, and empties the input buffer, **cdx(D/A)**, at the same time. This causes the A/D data to be transmitted by the CSP1027 to the DSP during the next CSP1027 time slot. The DSP's receive address is set to match the CSP1027's transmit address.
- When the DSP receives A/D data from the CSP1027, it responds by sending D/A data to the CSP1027 during the DSP's next time slot. The DSP's transmit address is set to match the CSP1027's data receive address. The new data is loaded into the CSP1027's **cdx(D/A)** register to be used as the next D/A sample.
- If the DSP wants to send a control word to the CSP1027 to change the configuration or inactivate the codec, this can be done by setting the DSP's transmit address to match the codec's control receive address.

Note that since the CSP1027 sends all zeros for the protocol information, this will have to be used to identify the A/D data from the CSP1027. If two CSP1027s are connected to the multiprocessor bus and the DSP's receive address is set to match both CSP1027's transmit addresses, the DSP will have to identify which A/D data came from which CSP1027 by the order in which the data arrives, since both CSP1027s will be sending the same protocol information.

4 Architectural Information (continued)

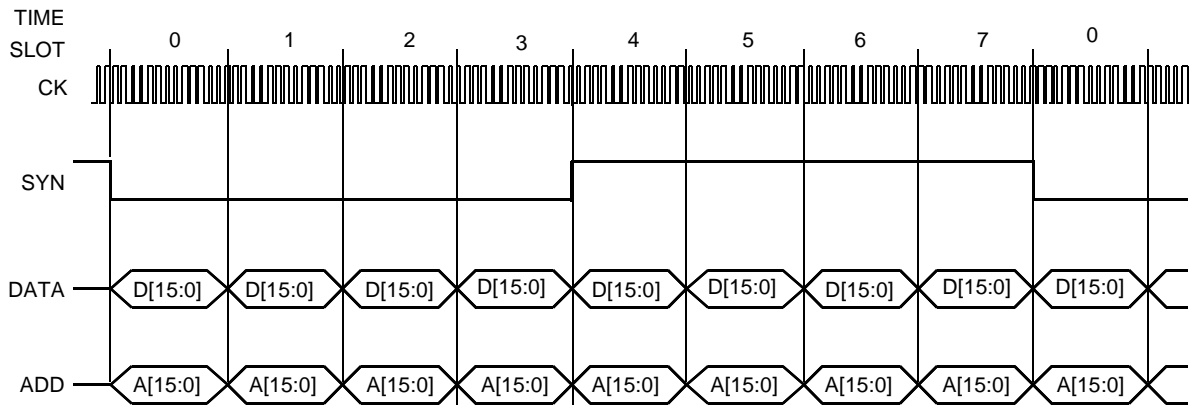

5-4185 (F).a

Figure 25. Multiprocessor Frame Timing

Table 6. Hardwired CSP1027 Multiprocessor Time Slot and Addresses

	SMODE0 = 0	SMODE0 = 1
Transmit Time Slot	2	5
Data, cdx(A/D) , Transmit Address [7:0]	0000 0100	0010 0000
Data, cdx(D/A) , Receive Address [7:0]	0000 1000	0100 0000
Control, cioc [0:3], Receive Address [7:0]	0001 0000	1000 0000

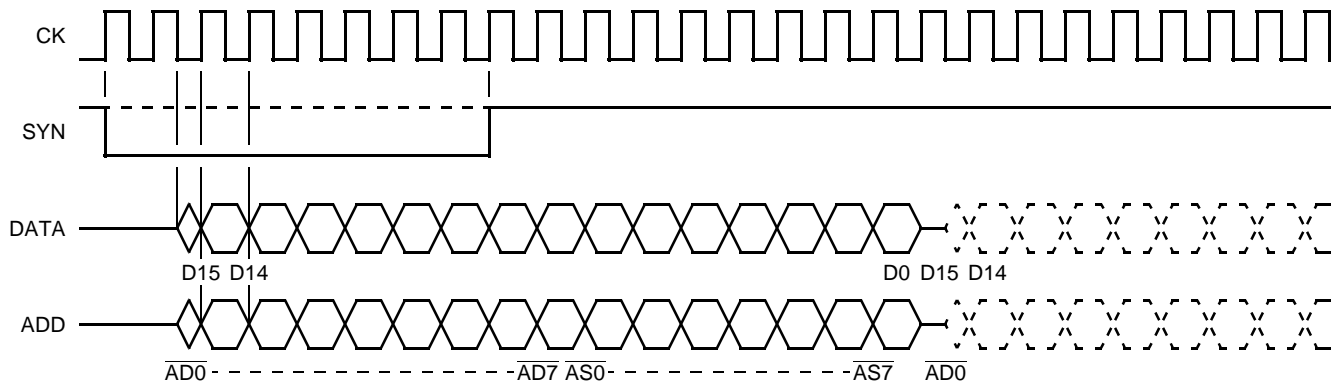

5-7605 (F)

Figure 26. Multiprocessor Time-Slot Timing

5 Register Information

Tables 7 through 10 describe the programmable registers of the CSP1027 device.

5.1 Codec I/O Control 0 (cioc0) Register

Table 7. Codec I/O Control 0 (cioc0) Register

Bit	15—14	13	12	11—8	7	6	5	4—0
Field	Reg	TEST	ACTIVE	OGSEL	MUTE	IRSEL	INSEL	CDIV2
Field	Value	Description						
Reg	00	Indicates control register 0.						
TEST	0*	Normal operation.						
	1	Testability mode—analog and digital loopback.						
ACTIVE	0*	Codec set to inactive mode (i.e., powerdown).						
	1	Codec set to active mode.						
OGSEL	1111	Output gain adjustment of 0 dB.						
	1110	Output gain adjustment of –3 dB.						
	1101	Output gain adjustment of –6 dB.						
	.	.						
	.	.						
	.	.						
	0001	Output gain adjustment of –42 dB.						
0000*	Output gain adjustment of –45 dB.							
MUTE	0*	Output signal muted.						
	1	Output signal not muted.						
IRSEL	0*	Microphone preamplifier input range: 500 mVp.						
	1	Microphone preamplifier input range: 160 mVp.						
INSEL	0*	Select microphone input, MICIN.						
	1	Select auxiliary input, AUXIN.						
CDIV2	0 0000	Output clock 2, CKO2, disabled.						
	0 0001	Output clock 2, CKO2 = ICLK ÷ 1.						
	0 0010	Output clock 2, CKO2 = ICLK ÷ 2.						
	.	.						
	.	.						
	.	.						
	1 0000*	Output clock 2, CKO2 = ICLK ÷ 16.						
	.	.						
	.	.						
	.	.						
1 1110	Output clock 2, CKO2 = ICLK ÷ 30.							
1 1111	Output clock 2, CKO2 = ICLK ÷ 31.							

* Value upon reset.

5 Register Information (continued)

5.2 Codec I/O Control 1 (cioc1) Register

Table 8. Codec I/O Control 1 (cioc1) Register

Bit	15—14	13	12—6	5	4—0
Field	Reg	ADJMOD	ADJ[6:0]	CDIV0	CDIV1
Field	Value	Description			
Reg	01	Indicates control register 0.			
ADJMOD	0*	Select retard mode for internal clock, ICLK0, adjustment.			
	1	Select advance mode for internal clock, ICLK0, adjustment.			
ADJ	000 0000*	Internal clock, ICLK0, not adjusted.			
	000 0001	Internal clock, ICLK0, adjusted by one ICLK cycle for one ICLK0 cycle.			
	000 0010	Internal clock, ICLK0, adjusted by one ICLK cycle for two ICLK0 cycles.			
	.	.			
	.	.			
	111 1110	Internal clock, ICLK0, adjusted by one ICLK cycle for 126 ICLK0 cycles.			
	111 1111	Internal clock, ICLK0, adjusted by one ICLK cycle for 127 ICLK0 cycles.			
CDIV0	0	Internal clock, $ICLK0 = ICLK \div 1$.			
	1*	Internal clock, $ICLK0 = ICLK \div 2$.			
CDIV1	0 0000	Output clock 1, CKO1, disabled.			
	0 0001	Output clock 1, $CKO1 = ICLK0 \div 1$.			
	0 0010	Output clock 1, $CKO1 = ICLK0 \div 2$.			
	.	.			
	.	.			
	1 0000*	Output clock 1, $CKO1 = ICLK0 \div 16$.			
	.	.			
	.	.			
	1 1110	Output clock 1, $CKO1 = ICLK0 \div 30$.			
1 1111	Output clock 1, $CKO1 = ICLK0 \div 31$.				

* Value upon reset.

5 Register Information (continued)

5.3 Codec I/O Control 2 (cioc2) Register

Table 9. Codec I/O Control 2 (cioc2) Register

Bit	15—14	13	12	11—6	5—0
Field	Reg	Reserved	CDIFS	CDIF0	CDIV3
Field	Value	Description			
Reg	10	Indicates control register 0.			
Reserved	0*	Reserved, always write 0.			
CDIFS	0*	Sampling rate, $CKs = ICLK0 \div (CDIV3 \times 125)$. Sampling rate, $CKs = ICLK0 \div 256$. (Note: CDIV3 must be set to 2.)			
	1	Sampling rate, $CKs = ICLK0 \div 1458$. (Note: CDIV3 must be set to 12.)			
	W	Sampling rate, $CKs = ICLK0 \div (125 \times M + S \times N)$. See Section 4.5 on page 16.			
CDIF0	00 0000*	Sampling rate, $CKs = ICLK0 \div (CDIV3 \times 125)$.			
	01 0101	Sampling rate, $CKs = ICLK0 \div 256$. (Note: CDIV3 must be set to 2.)			
	00 0011	Sampling rate, $CKs = ICLK0 \div 1458$. (Note: CDIV3 must be set to 12.)			
	WW WWWW	Sampling rate, $CKs = ICLK0 \div (125 \times M + S \times N)$. See Section 4.5 on page 16.			
CDIV3	00 0001	Oversampling clock, $CKos = ICLK0 \div 1$.			
	00 0010	Oversampling clock, $CKos = ICLK0 \div 2$.			
	.	.			
	.	.			
	.	.			
	11 1111	Oversampling clock, $CKos = ICLK0 \div 63$.			
	00 0000*	Oversampling clock, $CKos = ICLK0 \div 64$.			
WW WWWW	Sampling rate, $CKs = ICLK0 \div (125 \times M + S \times N)$. See Section 4.5 on page 16.				

* Value upon reset.

5 Register Information (continued)

5.4 Codec I/O Control 3 (cioc3) Register

Table 10. Codec I/O Control 3 (cioc3) Register

Bit	15—14	13	12	11	10—6	5—0
Field	Reg	TSTPOR	HPFE	DITHER	CDIF2	CDIF1
Field	Value	Description				
Reg	11	Indicates control register 0.				
TSTPOR	0*	Normal operation.				
	1	Test on-chip power-on reset pulse generator.				
HPFE	0*	Enable high-pass filter in A/D and D/A.				
	1	Disable high-pass filter in A/D and D/A.				
DITHER	0*	Enable dither on D/A converter.				
	1	Disable dither on D/A converter.				
CDIF2	0 0000*	Sampling rate, $CKs = ICLK0 \div (CDIV3 \times 125)$.				
	0 0000	Sampling rate, $CKs = ICLK0 \div 256$. (Note: CDIV3 must be set to 2.)				
	0 0000	Sampling rate, $CKs = ICLK0 \div 1458$. (Note: CDIV3 must be set to 12.)				
	W WWWW	Sampling rate, $CKs = ICLK0 \div (125 \times M + S \times N)$. See Section 4.5 on page 16.				
CDIF1	00 0000*	Sampling rate, $CKs = ICLK0 \div (CDIV3 \times 125)$.				
	10 0110	Sampling rate, $CKs = ICLK0 \div 256$. (Note: CDIV3 must be set to 2.)				
	11 0110	Sampling rate, $CKs = ICLK0 \div 1458$. (Note: CDIV3 must be set to 12.)				
	WW WWWW	Sampling rate, $CKs = ICLK0 \div (125 \times M + S \times N)$. See Section 4.5 on page 16.				

* Value upon reset.

6 Signal Descriptions

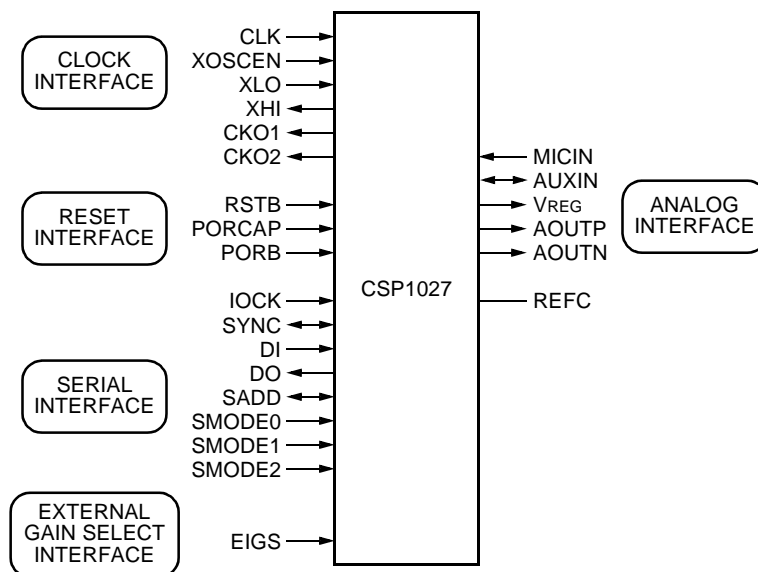

5-7606 (F)

Figure 27. CSP1027 Pinout by Interface

Figure 27 shows the pinout by interface for the CSP1027. The signals can be separated into five interfaces as shown. These interfaces and the signals that comprise them are described below.

6.1 Clock Interface

The clock interface consists of the clock input, crystal oscillator, and clock outputs for the codec.

6.1.1 CLK

Clock Input: The input clock for the CSP1027 when the XOSCEN is a logic low. Codec operation restricts CLK to integer frequencies from 1 MHz to 40 MHz or specific multiples of 8 kHz. When XOSCEN is tied to logic high, the CLK input is not selected but should be tied low or high to minimize input buffer power.

6.1.2 XLO

Crystal Input: The crystal for CSP1027 voice band codec is connected between XLO and XHI. When the crystal is not being used, this pin is to be left floating and the CMOS clock applied to CLK.

6.1.3 XHI

Crystal Output: The crystal for CSP1027 handset codec is connected between XLO and XHI. When the crystal is not being used, this pin is to be left floating and the CMOS clock applied to CLK.

6.1.4 XOSCEN

Crystal Oscillator Enable: When a logic high, the crystal oscillator is selected for XLO and XHI pins. When a logic low, the input buffer is selected for CLK pin and the crystal oscillator is powered down.

Note: The XOSCEN pin does not have a pull-up or pull-down device. Make sure that it is tied to VDD, tied to VSS, or driven by valid logic levels.

6 Signal Descriptions (continued)

6.1.5 CKO1

Clock Out 1: $ICLK \div CDIV1$ (see Table 8 on page 27). General-purpose output clock that can be used by a baseband codec, such as the CSP1084.

6.1.6 CKO2

Clock Out 2: $CLK \div CDIV2$ (see Table 7 on page 26). General-purpose output clock that can be used by a processor, such as the DSP1616.

6.2 Reset Interface

The reset interface consists of the reset input, power-on reset input, and power-on reset output for the codec.

6.2.1 RSTB

Reset: A high-to-low transition causes entry into the reset state. The **cioc**[0:3] register bits are set to their default states.

6.2.2 PORB

Power-On Reset: A high-to-low transition indicates entry into the power-on reset state.

6.2.3 PORCAP

Power-On Reset Capacitor: A capacitor is to be attached to this pin for the power-on reset circuit. PORCAP has an internal resistor (nominal value of 155 k Ω) connected to digital power, VDD.

6.3 Serial I/O Interface

The serial I/O interface consists of the serial clock input, synchronizing signal, data input, data output, serial address, and serial modes for the codec.

6.3.1 SMODE 0

Serial Mode 0: Configures the CSP1027 serial I/O interface. When in active/passive mode (SMODE1 low), SYNC is an output when SMODE0 is high, and SYNC is an input when SMODE0 is low. In multiprocessor mode (SMODE1 high), SMODE0 selects between two possible time slots, and between two possible transmit and receive address combinations. See Table 6 on page 25 in the architectural information for the addresses.

6.3.2 SMODE1

Serial Mode 1: Configures the CSP1027 serial I/O interface to multiprocessor mode when active-high; otherwise, active/passive mode is selected when low.

6.3.3 SMODE2

Serial Mode 2: Must be tied low to configure the CSP1027 serial I/O interface as described.

6.3.4 DI

Serial Data Input: Serial data input is latched on rising edge of IOCK, MSB first. DI and DO should be connected together when in multiprocessor mode.

6.3.5 DO

Serial Data Output: Serial data output from the output shift register (**osr**), MSB first, when the data register, **cdx(A/D)**, is selected or codec status flag when the control registers, **cioc**[0:3], are selected. When an output, DO changes on the rising edges of IOCK. DI and DO should be connected together when in multiprocessor mode, SMODE1 high.

6.3.6 IOCK

Serial Input/Output Clock: Input clock for serial PCM input and output data.

Note: The frequency of the serial I/O interface clock input IOCK (FIOCK) must be greater than the frequency of the internal oversampling clock CKOS (FCKOS).

6.3.7 SYNC

Serial Input/Output Load Strobe and Sync: When not in multiprocessor mode, the falling edge of SYNC indicates the beginning of a serial input and a serial output word. The falling edge of SYNC loads the output shift register (**osr**) from the codec data register (**cdx(A/D)**). Sixteen IOCK clock cycles after the falling edge of SYNC, the codec data (**cdx(D/A)**) or control register (**cioc**) is loaded from the input shift register (**isr**). SYNC is an input when the SMODE0 pin is low and an output when the SMODE0 pin is high.

In multiprocessor mode, SYNC is the multiprocessor synchronization input signal. A falling edge of SYNC indicates the first word of a TDM I/O stream and causes the resynchronization of the internal input and output load generators.

6 Signal Descriptions (continued)

6.3.8 SADD

Serial Address: When not in multiprocessor mode, SADD is an input that selects between the codec data registers, **cdx(D/A)** and **cdx(A/D)**, and codec control registers, **cioc**[0:3]. SADD is inverted and latched on the rising edge of IOCK and compared against a zero for data and a one for control, to determine if input data on DI is loaded from the input shift register (**isr**) into **cdx(D/A)** or one of **cioc**[0:3]. Once SADD indicates a control word, the internal codec status flag appears on DO, replacing **cdx(A/D)**. While not performing a serial transmission, SADD low causes the internal codec status flag to be output on DO.

In multiprocessor mode, SADD is an output when the **tdms** time slot dictates a serial output transmission; otherwise, it is an input. While an output, SADD is the inverted 8-bit serial transmit address output, LSB first. SADD changes on the rising edges of IOCK. While an input, SADD is inverted and latched on the rising edge of IOCK and compared against the **cdx(D/A)** and **cioc**[0:3] serial receive addresses to determine if input data on DI is loaded from the input shift register (**isr**) into **cdx(D/A)** or **cioc**.

6.4 External Gain Control Interface

The external gain control interface consists of one input.

6.4.1 EIGS

External Input Gain Select: A logic low or no connect selects the microphone preamplifier. A logic high selects the single op amp input mode where external resistors set the A/D input range. Note that EIGS is a digital pin whose input levels are relative to digital power and ground (V_{DD} and V_{SS}).

6.5 Digital Power and Ground

V_{DD}

Digital Power Supply: 3.0 V to 5.0 V supply.

V_{SS}

Digital Ground: 0 V.

6.6 Analog Interface

The analog interface consists of the two inputs, two outputs, a regulated output voltage reference, and a capacitor connection for the codec.

6.6.1 MICIN

Analog Input from Microphone: Low-level analog signal from electret condenser microphone selected by INSEL bit in codec control register, **cioc0** (see Table 7 on page 26).

6.6.2 AUXIN

Analog Input from Auxiliary: When used in preamplifier mode ($EIGS = 0$), AUXIN is a low-level analog signal selected by INSEL bit in codec control register, **cioc0** (see Table 7 on page 26). The characteristics of AUXIN are identical to MICIN.

When used in external gain select mode ($EIGS = 1$), AUXIN is the output of the inverting amplifier. The INSEL bit has no effect in this mode.

6.6.3 AOOUTP

Noninverting Analog Output: In conjunction with AOOUTN, this output can drive a 2 k Ω load in differential mode or a 1 k Ω load ac-coupled to analog ground.

6.6.4 AOOUTN

Inverting Analog Output: In conjunction with AOOUTP, this output can drive a 2 k Ω load in differential mode or a 1 k Ω load ac-coupled to ground.

6.6.5 VREG

Regulated Output Voltage: For electret condenser microphone. $V_{out} = 3\text{ V} \pm 10\%$, $I_{out} = 250\ \mu\text{A}$ max. A 1 μF and 0.1 μF ceramic type X7R capacitor to ground must be provided at this pin (see Figure 28 on page 34).

6.6.6 REFC

External Capacitor Connection: Internal voltage regulator bypassing. A 0.22 μF ceramic type X7R capacitor to ground must be provided at this pin.

6.7 Analog Power and Ground

V_{DDA}

Analog Power Supply: 5.0 V supply.

V_{SSA}

Analog Ground: 0 V.

7 Application Information

This section begins with application information for the analog section, followed by power distribution, crystal oscillator, and codec clock generation programming examples.

7.1 Analog Information

The A/D input block is covered first, followed by the D/A, and the microphone voltage regulator.

7.1.1 A/D in the Preamplifier Mode

Figure 28 on page 34 shows a typical telephone handset application. The codec is shown with the preamp mode (EIGS = VSS) selected and connected to a microphone. The analog-to-digital conversion path begins with an on-chip preamplifier front end having two single-ended inputs. The preamp inputs are MICIN and AUXIN. Selection of MICIN or AUXIN is made via the INSEL field in the **cioc0** register (see Table 8 on page 27) and can be dynamically changed, as desired. The electrical specifications for both inputs are the same.

An off-chip ac-coupling capacitor, Cin, is required before each input. However, if either input is unused, it may be left unconnected (floating). The input resistance (Rin) to either MICIN or AUXIN is approximately 40 kΩ. The recommended value of Cin is 0.15 μF. This creates a high-pass filter pole at approximately 26 Hz. A larger capacitor value may be used if desired, in order to allow lower frequencies to pass to the A/D converter, but smaller capacitor values are not recommended.

7.1.2 A/D in the External Input Gain Select Mode

The external input gain select (EIGS = VDD) is used when the input range is set by the user (see Section 4.3 on page 13). The A/D input circuitry of Figure 28 on page 34 is modified as shown in Figure 5 on page 7. When EIGS = VDD, the following notes apply.

1. The recommended range of values for the feedback resistor and capacitor are the following:
10 kΩ ≤ Rfb ≤ 45 kΩ and 150 pF ≤ Cfb ≤ 680 pF.
2. The $\frac{Rfb}{Rin}$ external resistor ratio accuracy directly impacts the absolute accuracy of the A/D path. A 1% ratio error adds 86 mdB of absolute gain error.

3. The A/D input sampling switches have an effective bandwidth on the order of 15 MHz. The amplifier unity gain frequency is on the order of 3 MHz. High-frequency noise in the 1 MHz to 50 MHz range that couples to the AUXIN pin will be somewhat attenuated by the amplifier output impedance, but a significant portion will be sampled by the A/D and aliased down to the baseband. Special care in circuit board layout is required to keep noise sources from coupling into the AUXIN or MICIN pins so that the noise and distortion performance shown in Table 16 on page 52 can be achieved.

The codec is not as sensitive to wideband noise when the preamplifier is used (EIGS = VSS) because the A/D inputs are driven from an on-chip low-pass filter.

4. The external gain mode input circuitry of Figure 5 on page 7 is an integrator with a great deal of loss. The frequency response of Table 16 on page 52 assumes that the Rfb × Cfb corner frequency is 25 kHz so the 3 kHz droop is less than 65 dBm. Similarly, the Cin × Rin corner frequency is set to 7 Hz. These RC combinations create a bandpass anti-aliasing filter with corner frequencies given by:

$$f_{LO} = \frac{1}{2\pi \times Rin \times Cin} \quad f_{HI} = \frac{1}{2\pi \times Rfb \times Cfb}$$

When selecting component values, verify that the A/D frequency response will still meet the application requirements.

7.1.3 D/A Analog Output

The CSP1027 D/A has two analog outputs, AOUTP and AOUTN, capable of operating as two single-ended drivers, or a single fully differential driver. The output impedance of each is no more than 6 Ω (12 Ω if configured as fully differential) over the dc to 4 kHz frequency range.

The maximum open-circuit output levels are 2.1 Vp (4.2 Vp-p) if fully differential, and one-half of these levels if single-ended. These levels correspond to a full-scale 16-bit two's complement PCM input into the D/A converter, with the output gain setting (OGSEL) at 0 dB. For any given PCM input, the output levels will be reduced by a voltage division of the D/A output and the load impedance:

$$V_{OUT} = V_O \times \frac{R_L}{R_O + R_L}$$

The driver linearity is only guaranteed for the single-ended output load resistance (RL) of at least 1000 Ω and the differential output load resistance (RL) of at least 2000 Ω.

7 Application Information (continued)

Figure 29 (A—E) on page 35 illustrates five different analog output configurations. In Figure 29A, the output load is driven in a fully differential manner. It is assumed that the load is floating, having no path to ground. Figure 29B is similar, but ac-coupling capacitors are used. A low-pass pole is created, whose frequency should be less than 30 Hz in order to not interfere with the voice band frequency response.

In Figure 29C—E, different variations of single-ended loads are shown. In any single-ended configuration, ac-coupling capacitors are required.

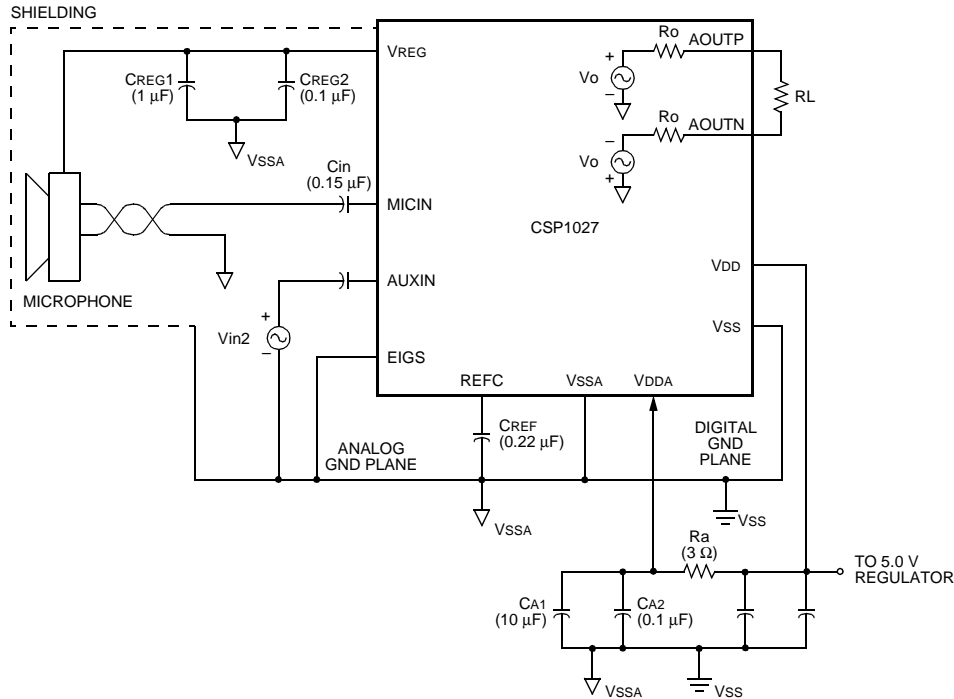

5-7607 (F)

- Notes:
- Analog (VSSA) and digital (VSS) ground pins are tied together to prevent substrate currents from ground bounce.
 - Capacitors CA2, CD2, CREF, CREG1, and CREG2 should be type X7R ceramic.
 - Capacitors CA1 and CD1 should be tantalum or low ESR aluminum.
 - All capacitors should be located as close to the chip pins as possible.
 - Keep analog and digital grounds separate, and then join at the VSSA pin.
 - Keep the regulator as close to the chip as possible.
 - The power connections are shown when the analog and digital are run from 5.0 V. When the digital is run from a 3.3 V power supply, CD1 and CD2 go from the 3.3 V regulator to ground, and Ra goes to the 5.0 V regulator.

Figure 28. Analog External Configurations in Pre-amplifier Mode (EIGS = 0)

7 Application Information (continued)

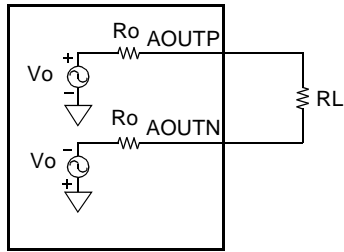

A. Fully Differential

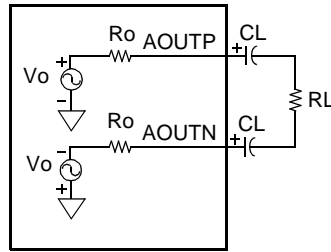

B. Fully Differential, with Capacitive Coupling

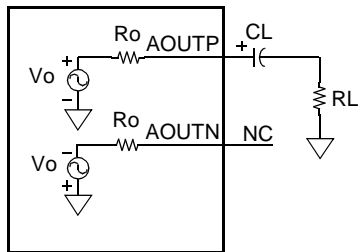

C. Single-Ended, AOUTP

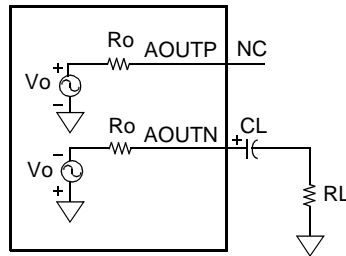

D. Single-Ended, AOUTN

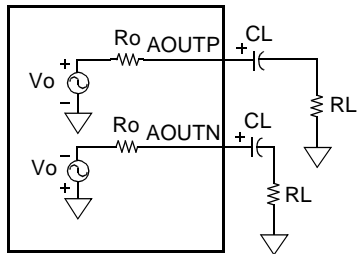

E. Dual Single-Ended

5-7608 (F)

Figure 29. Analog Output Configurations

7 Application Information (continued)

7.1.4 Microphone Regulator

VREG is a 3.0 V regulated supply that provides up to 250 μ A to an external microphone or other device (see Figure 28 on page 34). The regulator uses the external capacitors CREG1 and CREG2 to band limit its noise and for frequency compensation. The CREG1 off-chip capacitor (1 μ F) is required in order to meet the noise specification of 100 μ V on VREG. CREG2 (0.1 μ F) should be placed in parallel with CREG1 to improve high-frequency noise filtering. The minimum value of the CREG1 and CREG2 combination is 0.1 μ F for VREG to be stable. If VREG is not used, this pin should be either connected through a 0.1 μ F capacitor to analog ground (VSSA) or tied directly to ground. Connecting VREG to ground will produce a dc current of 250 μ A to 400 μ A out the VREG pin, but will not change the total supply current. Do not leave the VREG pin unconnected because it will oscillate.

7.2 Power Supply Configuration

Figure 28 on page 34 illustrates the recommended configuration for the analog and digital power and grounds.

An external supply feeds an off-chip voltage regulator. Capacitor CD1 (10 μ F) and CD2 (0.1 μ F) are used for decoupling the noise on the VDD digital power bus. Capacitors CA1 (10 μ F) and CA2 (0.1 μ F) are for decoupling the noise on the analog power bus (VDDA). The Ra resistor (3 Ω) decouples the analog and digital power buses when a common 5.0 V power supply is used. The analog and digital circuits share the same substrate since this codec is a monolithic device. In the technology used to fabricate the device, the substrate is connected to ground. To avoid large substrate currents caused by digital ground-bounce, it is recommended that the analog and digital grounds be tied together at the package, as shown in Figure 28 on page 34. It is recommended that the analog and digital ground planes also meet at this point. In a typical application where the CSP1027 is interfaced to a DSP, it is advisable to place the DSP as close to the codec as possible, with the DSP's digital ground plane extending to the points where the SIO lines meet the CSP1027.

7.2.1 REFC Capacitor

An off-chip capacitor, CREF (0.22 μ F), is required on pin REFC in order to meet the noise requirements for the internal signal paths.

7.2.2 Capacitor Proximity to Pins

In all cases, the external capacitors should be placed as closely as possible to the CSP1027 pins, in order to meet the noise specifications.

7.3 The Need for Fully Synchronous Operation

7.3.1 Introduction to Sampled Data Systems

The analog circuits in the A/D and D/A converters are sampled data circuits. This means that there are switches that close to sample the signal and then open to hold the signal. An example of this kind of discrete time analog circuit is the well-known switched capacitor technique used to implement A/D and D/A converter circuits as well as filters.

A fundamental property of any sampled data system is that any noise or signal that is in the signal path when the sampling switches open is sampled. The sampling process modulates the noise and signal about multiples of the sample clock rate. For a sample rate of fs and a noise tone at a frequency of fn, this modulation process produces new tones at

$$(k \times fs) \pm fn,$$

where $k = 1, 2, 3, \dots$. For noise near a multiple of fs, the difference term can modulate all the way down to baseband and be heard as a tone.

A typical source of noise is that generated by the normal operation of the digital circuits. The digital circuits tend to have fast edge transitions (large dv/dt and di/dt). The dv/dt changes couple into the analog signal path through parasitic capacitance on-chip and in the circuit board. The di/dt changes cause voltages to be generated across parasitic inductance and cause ground-bounce on-chip. The ground-bounce can turn on intrinsic parasitic diodes to the substrate of the CSP1027, and the subsequent substrate currents can couple the noise into the analog circuits. The di/dt transients are also inductively coupled into the off-chip analog routing and thus added to the analog signals. Layout techniques help reduce the dv/dt and di/dt coupling, but it is very difficult to eliminate it.

To gauge the magnitude of the problem, consider the numbers from the CSP1027. The digital logic swing is ground to VDD, which can be as large as 5.5 V. The full-scale preamplifier input level (when IRSEL = 1) is 160 mVp, and the A/D path has a noise floor that is guaranteed to be 70 dB below full scale. For the digital noise to raise the noise floor by less than 3 dB, the

7 Application Information (continued)

noise must be less than 36 μV_{rms} referred to the preamplifier input. As a worst-case analysis, assume that all the digital noise is in the baseband (noise source of 2.5 V_{rms} for a 5.0 V digital signal). The attenuation (isolation) between the digital signal and the preamplifier for this case must be

$$\text{isolation} \approx \frac{2.5 \text{ V}}{36 \mu\text{V}} = 70,000:1 \text{ (97 dB)}$$

Usually, only a small portion of a particular digital signal ac-couples into the signal path, but this is tempered by having many digital signals. It is the sum of these noise sources that must be held to less than 36 μV_{rms} . In audio applications, the needed isolation is actually greater than calculated above because the human ear can detect tones that are 10 dB below the noise floor.

7.3.2 Typical Ways Digital Noise Couples into Analog Circuits

1. Digital signals have overshoot or undershoot because of circuit board impedance mismatches. These reflections can turn on internal I/O protection diodes. The diodes then inject the noise current into the substrate as well as the chip power rails, and the noise is distributed throughout the chip.
2. Fine-line CMOS (like that used to fabricate the CSP1027) generates hot electron currents when the logic gates change state. This current is injected into the substrate and adds to the supply current. The substrate current can couple directly into the analog circuits, and the supply current transients can couple through common supply impedance and by inductive coupling.
3. Coupling off-chip, such as the package bond wires and package pins, and coupling into the analog signals on the circuit board.
4. The classic coupling method: common power and ground impedance.

7.3.3 The Problem with an Asynchronous Codec Clock

When the I/O and sample clocks are not derived from the same time base, their edges will drift with time. Even if the I/O and sample time bases use master oscillators that are stated to be the same frequency (or one being a multiple of the other), they will differ by some amount from their intended values. This difference in frequency will cause the digital circuit clock edges to slide past the analog sample clock edges in a periodic way, causing the sampled digital noise to also vary in the same periodic way (noise tones in the baseband).

7.3.4 The Advantage of Fully Synchronous Operation

When all the clocks that are used in or connected to the codec are generated from the same master time base, the sampling switches sample in the quiet time before the digital circuits change state, or at least sample the same portion of the ground bounce transient. The portion of the noise that does not change from one sample to the next will alias to the signal path as a dc offset. The portion that is signal dependent (like a data line coupling into the analog signal path) can show up as a tone even though its transitions occur synchronously with the sample clock unless care is taken to ensure that the analog sampling switches only open during a quiet time (usually before the digital circuits change state).

7 Application Information (continued)

7.4 Crystal Oscillator

If the option for using the external crystal is chosen, the following electrical characteristics and requirements apply.

7.4.1 External Components

The crystal oscillator is enabled by connecting a crystal across XLO and XHI, along with one external capacitor from each of these pins to ground (see Figure 30). For most applications, 10 pF external capacitors are recommended; however, larger values may be necessary if precise frequency tolerance is required (see Section 7.4.5 on page 43). The crystal should be either fundamental or overtone mode, be parallel resonant, have a power dissipation of at least 1 mW, and be specified at a load capacitance equal to the total capacitance seen by the crystal (including external capacitors and strays). The series resistance of the crystal should be specified to be less than **half** the absolute value of the negative resistance shown in Figures 31 or 32 on page 39 for the crystal frequency. The frequency of the internal clock will be equal to the crystal frequency.

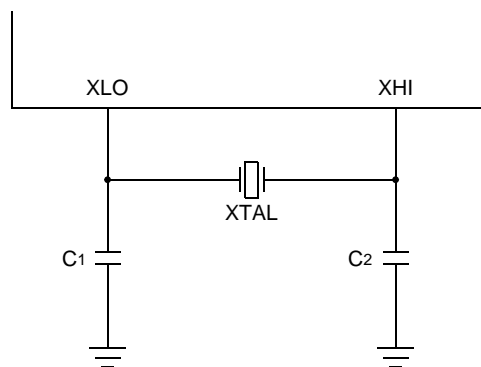

5-7609 (F)

Figure 30. Fundamental Crystal Configuration

7.4.2 Power Dissipation

Figures 33 and 34 on page 40 indicate the typical power dissipation of the on-chip crystal oscillator circuit versus frequency.

7 Application Information (continued)

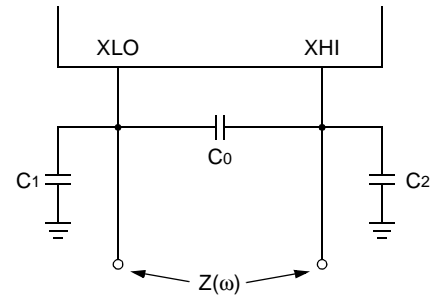
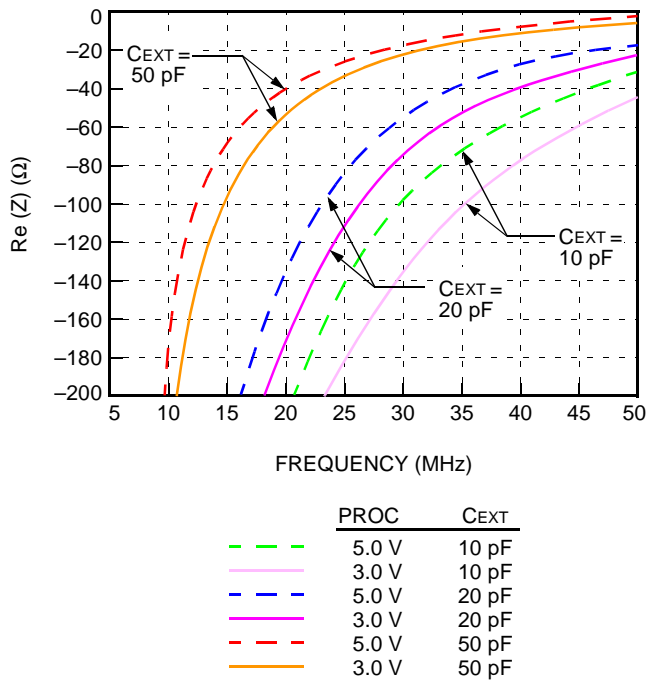

C₁ = C₂ = C_{EXT}
C₀ = PARASITIC CAPACITANCE OF CRYSTAL (7 pF MAXIMUM)

5-7610 (F)

Figure 31. Negative Resistance of Crystal Oscillator Circuit, V_{DD} = 4.75 V

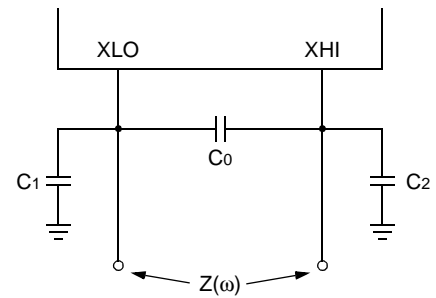
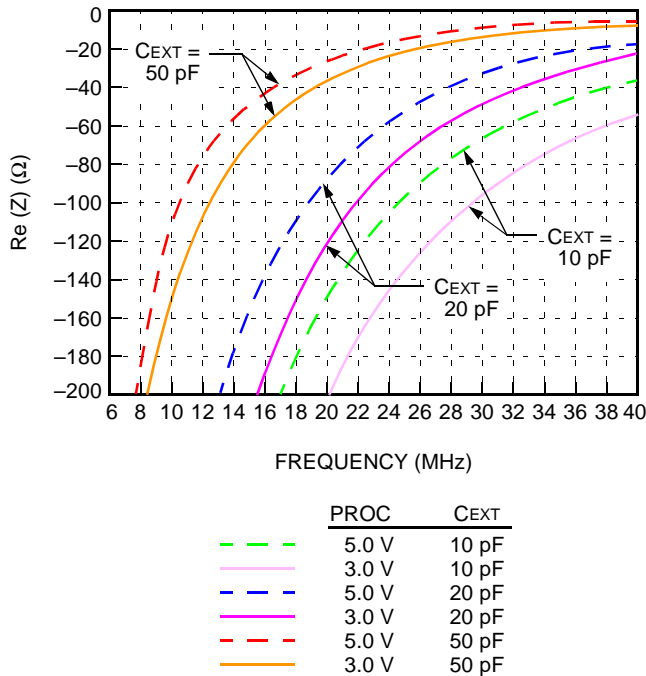

C₁ = C₂ = C_{EXT}
C₀ = PARASITIC CAPACITANCE OF CRYSTAL (7 pF MAXIMUM)

5-7611 (F)

Figure 32. Negative Resistance of Crystal Oscillator Circuit, V_{DD} = 3.0 V

7 Application Information (continued)

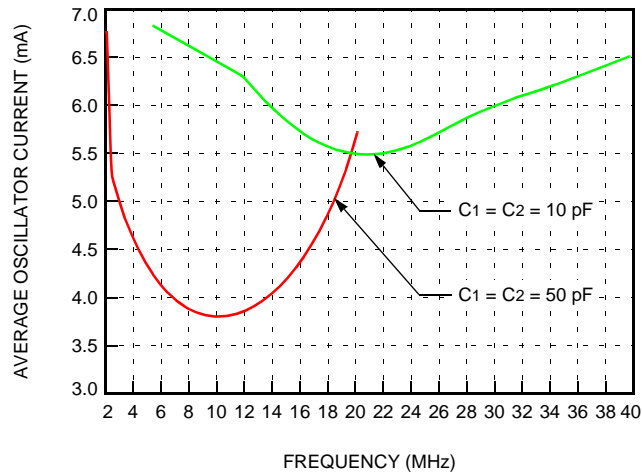

5-7612 (F)

Figure 33. Typical Supply Current of Crystal Oscillator Circuit, V_{DD} = 5.0 V, 25 °C

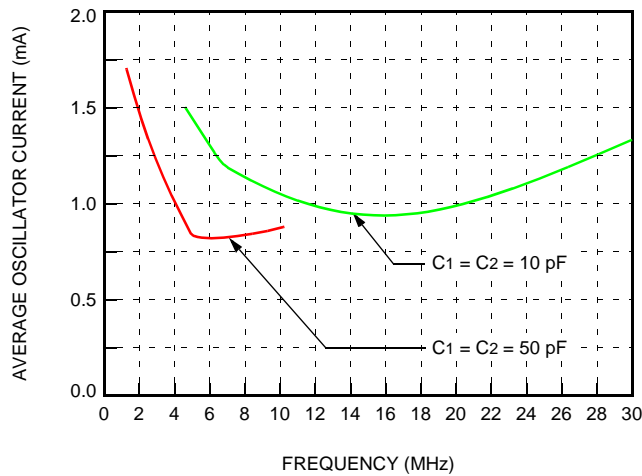

5-7613 (F)

Figure 34. Typical Supply Current of Crystal Oscillator Circuit, V_{DD} = 3.3 V, 25 °C

7 Application Information (continued)

7.4.3 Printed-Circuit Board Layout Considerations

The following guidelines should be followed when designing the printed-circuit board layout for a crystal-based application:

1. Keep crystal and external capacitors as close to XLO and XHI pins as possible to minimize board stray capacitance.
2. Keep high-frequency digital signals such as CKO1 and CKO2 away from XLO and XHI traces to avoid coupling into the oscillator.

7.4.4 LC Network Design for Third Overtone Crystal Circuits

For operating frequencies of greater than 30 MHz, it is usually cost advantageous to use a third overtone crystal as opposed to a fundamental mode crystal. When using third overtone crystals, it is necessary, however, to filter out the fundamental frequency so that the circuit will oscillate only at the third overtone. There are several techniques that will accomplish this; one of these is described below.

Figure 35 shows the basic setup for third overtone operation.

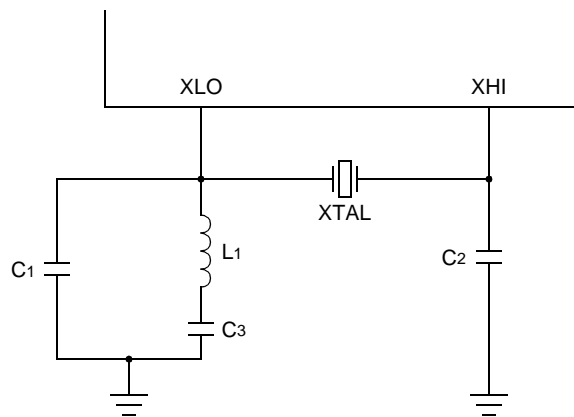

5-7614 (F)

Figure 35. Third Overtone Crystal Configuration

The parallel combination of L_1 and C_1 forms a resonant circuit with a resonant frequency between the first and third harmonic of the crystal such that the LC network appears inductive at the fundamental frequency and capacitive at the third harmonic. This ensures that a 360° phase shift around the oscillator loop will occur at the third overtone frequency but not at the fundamental. The blocking capacitor, C_3 , provides dc isolation for the trap circuit and should be chosen to be large compared to C_1 .

For example, suppose it is desired to operate with a 40 MHz, third overtone, crystal.

- Let:
- f_3 = operating frequency of third overtone crystal (40 MHz in this example)
 - f_1 = fundamental frequency of third overtone crystal, or $f_3/3$ (13.3 MHz in this example)
 - f_T = resonant frequency of trap = $\frac{1}{2\pi\sqrt{L_1C_1}}$
 - C_2 = external load capacitor (10 pF in this example)
 - C_3 = dc blocking capacitor (0.1 μ F in this example)

7 Application Information (continued)

Arbitrarily set trap resonance to geometric mean of f_1 and f_3 . Since $f_1 = f_3/3$, the geometric mean would be:

$$f_T = \frac{f_3}{\sqrt{3}} = \frac{40 \text{ MHz}}{\sqrt{3}} = 23 \text{ MHz}$$

At the third overtone frequency, f_3 , it is desirable to have the net impedance of the trap circuit (X_T) equal to the impedance of C_2 (X_{C2}), i.e.,

$$X_T = X_{C2} = X_{C1} \parallel (X_{C3} + X_{L1})$$

Selecting C_3 so that $X_{C3} \ll X_{L1}$ yields,

$$X_T = X_{C2} = X_{C1} \parallel X_{L1}$$

For a capacitor,

$$X_C = \frac{-j}{\omega C}$$

where $\omega = 2\pi f$.

For an inductor,

$$X_L = j\omega L$$

Solving for C_1 , and realizing that $L_1 C_1 = 3/\omega^2$ yields,

$$C_1 = \frac{3}{2} C_2$$

Hence, for $C_2 = 10 \text{ pF}$, $C_1 = 15 \text{ pF}$. Since the impedance of the trap circuit in this example would be equal to the impedance of a 10 pF capacitor, the negative resistance and supply current curves for $C_1 = C_2 = 10 \text{ pF}$ at 40 MHz would apply to this example.

Finally, solving for the inductor value, L_1 ,

$$L_1 = \frac{1}{4\pi^2 f_T^2 C_2}$$

For the above example, L_1 would be $3.2 \text{ }\mu\text{H}$.

7 Application Information (continued)

7.4.5 Frequency Accuracy Considerations

For most applications, clock frequency errors in the hundreds of parts per million (ppm) can be tolerated with no adverse effect. However, for applications where precise frequency tolerance on the order 100 ppm is required, care must be taken in the choice of external components (crystal and capacitors) as well as in the layout of the printed-circuit board. Several factors determine the frequency accuracy of a crystal-based oscillator circuit. Some of these factors are determined by the properties of the crystal itself. Generally, a low-cost, standard crystal will not be sufficient for a high-accuracy application, and a custom crystal must be specified. Most crystal manufacturers provide extensive information concerning the accuracy of their crystals, and an applications engineer from the crystal vendor should be consulted prior to specifying a crystal for a given application.

In addition to absolute, temperature, and aging tolerances of a crystal, the operating frequency of a crystal is also determined by the total load capacitance seen by the crystal. When ordering a crystal from a vendor, it is necessary to specify a load capacitance at which the operating frequency of the crystal will be measured. Variations in this load capacitance due to temperature and manufacturing variations will cause variations in the operating frequency of the oscillator. Figure 36 illustrates some of the sources of this variation.

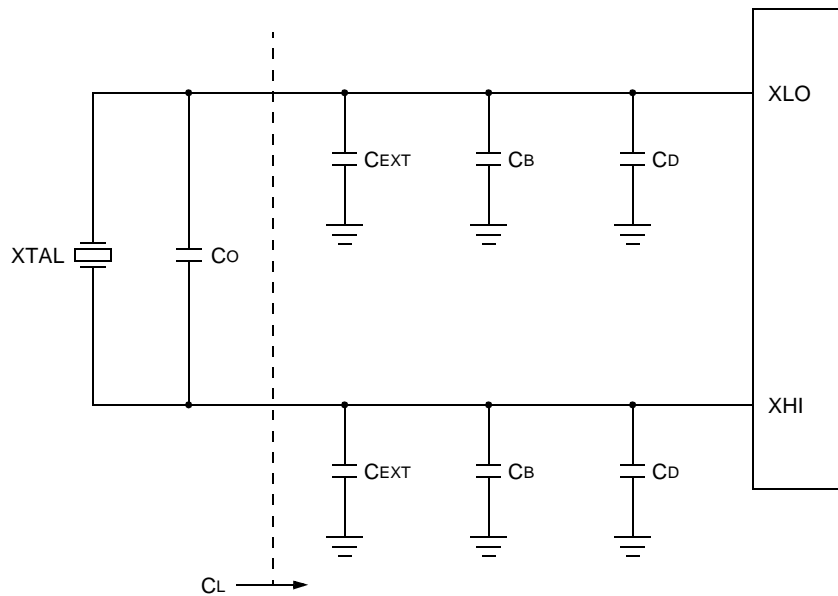

5-7615 (F)

Notes:

- CEXT = External load capacitor (one each required for XLO and XHI).
- CD = Parasitic capacitance of the CSP1027 itself.
- CB = Parasitic capacitance of the printed-wiring board.
- Co = Parasitic capacitance of crystal (not part of CL, but still a source of frequency variation).

Figure 36. Components of Load Capacitance for Crystal Oscillator

The load capacitance, CL, must be specified to the crystal vendor. The crystal manufacturer will cut the crystal so that the frequency of oscillation will be correct when the crystal sees this load capacitance. Note that CL refers to a capacitance seen across the crystal leads, meaning that for the circuit shown in Figure 36, CL is the series combination of the two external capacitors (CEXT/2) plus the equivalent board and device strays (CB/2 + CD/2). For example, if 10 pF external capacitors were used and parasitic capacitance is neglected, then the crystal should be specified for a load capacitance of 5 pF. If the load capacitance deviates from this value due to the tolerance on the external capacitors or the presence of strays, then the frequency will also deviate.

7 Application Information (continued)

This change in frequency as function of load capacitance is known as pullability and is expressed in units of ppm/pF. For small deviations of a few pF, pullability can be determined by the equation below.

$$\text{pullability (ppm/pF)} = \frac{(C_1)(10^6)}{2(C_0 + C_L)^2}$$

where

- C_0 = parasitic capacitance of crystal.
- C_1 = motional capacitance of crystal (usually around 1 fF—25 fF, value can be obtained from crystal vendor).
- C_L = total load capacitance seen by crystal.

Note that for a given crystal, the pullability can be reduced, and hence, the frequency stability improved, by making C_L as large as possible while still maintaining sufficient negative resistance to ensure start-up per the curves shown in Figures 31 and 32 on page 39.

Since it is not possible to know the exact values of the parasitic capacitance in a crystal-based oscillator system, the external capacitors are usually selected empirically to null out the frequency offset on a typical prototype board. Thus, if a crystal is specified to operate with a load capacitance of 10 pF, the external capacitors would have to be made slightly less than 20 pF each in order to account for strays. Suppose, for instance, that a crystal for which $C_L = 10$ pF is specified is plugged into the system and it is determined empirically that the best frequency accuracy occurs with $C_{EXT} = 18$ pF. This would mean that the equivalent board and device strays from each lead to ground would be 2 pF.

As an example, suppose it is desired to design a 26 MHz, 3.3 V system with ± 100 ppm frequency accuracy. The parameters for a typical high-accuracy, custom, 26 MHz fundamental mode crystal are as follows:

Initial Tolerance	10 ppm
Temperature Tolerance	25 ppm
Aging Tolerance	6 ppm
Series Resistance	20 Ω max
Motional Capacitance (C_1)	15 pF max
Parasitic Capacitance (C_0)	7 pF max

In order to ensure oscillator start-up, the negative resistance of the oscillator with load and parasitic capacitance must be at least twice the series resistance of the crystal, or 40 Ω . Interpolating from Figure 32 on page 39, external capacitors plus strays can be made as large as 30 pF while still achieving 40 Ω of negative resistance. Assume for this example that external capacitors are chosen so that the total load capacitance including strays is 30 pF per lead, or 15 pF total. Thus, a load capacitance, $C_L = 15$ pF would be specified to the crystal manufacturer.

From the above equation, the pullability would be calculated as follows:

$$\text{pullability} = \frac{(C_1)(10^6)}{2(C_0 + C_L)^2} = \frac{(0.015)(10^6)}{2(7 + 15)^2} = 15.5 \text{ ppm/pF}$$

If 2% external capacitors are used, the frequency deviation due to this variation is equal to

$$(0.02)(15 \text{ pF})(15.5 \text{ ppm/pF}) = 4.7 \text{ ppm.}$$

Note: To simplify analysis, C_{EXT} is considered to be 30 pF. In practice, it would be slightly less than this value to account for strays. Also, temperature and aging tolerance on the capacitors have been neglected.

Typical capacitance variation of oscillator circuit in the CSP1027 itself across process, temperature, and supply voltage is ± 1 pF. Thus, the expected frequency variation due to the CSP1027 is as follows:

$$(1 \text{ pF})(15.5 \text{ ppm/pF}) = 15.5 \text{ ppm.}$$

Approximate variation in parasitic capacitance of crystal = ± 0.5 pF.

Frequency shift due to variation in C_0 = $(0.5 \text{ pF})(15.5 \text{ ppm/pF}) = 7.75 \text{ ppm.}$

Approximate variation in parasitic capacitance of printed-circuit board = ± 1.5 pF.

Frequency shift due to variation in board capacitance = $(1.5 \text{ pF})(15.5 \text{ ppm/pF}) = 23.25 \text{ ppm.}$

7 Application Information (continued)

Thus, the contributions to frequency variation add up as follows:

Initial Tolerance of Crystal	10.0 ppm
Temperature Tolerance of Crystal	25.0 ppm
Aging Tolerance of Crystal	6.0 ppm
Load Capacitor Variation	4.7 ppm
CSP1027 Circuit Variation	15.5 ppm
C ₀ Variation	7.8 ppm
Board Variation	23.3 ppm
Total	92.3 ppm

This type of detailed analysis should be performed for any crystal-based application where frequency accuracy is critical.

7.5 Programmable Clock Generation

Refer to Figure 17 on page 15 for the following discussion.

The programmable clock divider is set by writing the 6-bit CDIV3 field of the **cioc2** register (see Table 9 on page 28). The user can select an appropriate integer value which sets the ratio of the CLK input clock to the oversampling rate of the codec. The following examples illustrate this feature.

7.5.1 Application Example 1

- GSM application.
- Input clock, CLK, rate: 26 MHz (38.46 ns).
- Codec PCM rate required: 8 kHz (oversampling rate = 1 MHz).

Solution:

- CLK/CKos = 26, so set CLK/ICLK0 = 1 and ICLK0/CKos to 26.
- Set CDIV0 = 0 and CDIV3 = 26 (011010).

7.5.2 Application Example 2

- IS-54 application.
- Input clock, CLK, rate: 40 MHz (25.0 ns).
- Codec PCM rate required: 8 kHz (oversampling rate = 1 MHz).

Solution:

- CLK/CKos = 40, so set CLK/ICLK0 = 1 and ICLK0/CKos to 40.
- Set CDIV0 = 0 and CDIV3 = 40 (101000).

7.5.3 Application Example 3

- Modem data pump.
- Codec sampling frequency required = 9.6 kHz (instead of 8 kHz).
- Need highest possible input clock, CLK, rate (allowable by the DSP).

Solution:

- Codec oversampling rate = 9.6 kHz * 125 = 1.2 MHz.
- Assuming a DSP16A or DSP1616 with maximum rate of 40 MHz, CLK = 39.6 MHz = 1.2 MHz x 33, so CLK/ICLK0 = 1 and ICLK0/CKos = 33.
- Set CDIV0 = 0 and CDIV3 = 33 (100001).
- Disable the high-pass filters (HPFE = 1) because the -3 dB corner frequency is now too high (270 Hz x 1.2 = 324 Hz).
- Low-pass filter -3 dB corner frequency is now 4.08 kHz (= 3.4 kHz x 1.2). (Note that external DSP software can provide additional postfiltering, if desired.)

7 Application Information (continued)

7.5.4 Enhanced Oversampling Clock Generation

If system constraints make the requirement of integer multiples of 125 x the sampling rate (typically integer multiples of 1.0 MHz) difficult to provide, the CSP1027 can also operate with the ICLK0 internal clock rate at integer multiples of the sampling rate (typically integer multiples of 8 kHz). See Section 4.5 on page 16 for more information.

The following two examples illustrate the usage:

Application Example 4

- Standard codec application.
- CLK input clock rate: 2.048 MHz.
- Codec sampling rate, fs: 8 kHz.

Solution:

- $CKOS = 125 \times 8 \text{ kHz} = 1.0 \text{ MHz}$, so $CLK/CKOS = 2.048$ or $CLK/CKs = 2.048 \times 125 = 256$. Values of M and N must be found to satisfy this requirement, as shown below.

- Set CDIV0 for $\div 1$ ($CDIV0 = 0$); hence, $f_{CLK} = f_{CLK}$.
- Using the equations from Section 4.5 on page 16,

$$\frac{F_{ICLK0}}{F_s} = (125 \times M) + (S \times 2)$$

$$\frac{F_{ICLK0}}{F_s} = \frac{2.048 \text{ MHz}}{8 \text{ kHz}} = 256 = (125 \times 2) + (1 \times 6)$$

Hence, $M = 2$, $S = 1$, and $N = 6$. (Note that if CDIV0 set for $\div 2$, then $M = 1$, $S = +1$, and $N = 3$, which is not allowed.)

- Using Tables 2 through 4 on page 18:

CDIV3 = 00 0010.
CDIFS = 0.
CDIF0 = 01 0101.
CDIF1 = 10 0110.
CDIF2 = 0 0000.

Application Example 5

- IS-54 application.
- Codec sampling rate, fs: 8 kHz.
- CLK needs to be a common multiple of 8 kHz and $48 \times 48.6 \text{ kHz}$.
- Need phase adjustment.

Solution:

- $48 \times 48.6 = 2.3328E6$
 $2.3328E6 \div 8E3 = 291.6$

To get a common multiple, 291.6 must be multiplied by a factor to become an integer: $291.6 \times 10 = 2916$ (an integer). So, $CLK/CKs = 2916$ and $CLK/ICLK0 = 2 \text{ CLK} = 2916 \times 8E3 = 23.328E6$.

- CLK input clock rate: 23.328 MHz.
- Set CDIV0 for $\div 2$ ($CDIV0 = 1$) to allow advance/retard for phase adjustment.
- ICLK0 internal clock rate is 11.664 MHz.
- Using the equations from Section 4.5 on page 16,

$$\frac{F_{ICLK0}}{F_s} = \frac{11.664 \text{ MHz}}{8 \text{ kHz}} = 1458 = (125 \times 12) + (-1 \times 42)$$

Hence, $M = 12$, $S = -1$, and $N = 42$.

- Using Tables 2 through 4 on page 18:
CDIV3 = 00 1100.
CDIFS = 1.
CDIF0 = 00 0011.
CDIF1 = 11 0110.
CDIF2 = 0 0000.

8 Device Characteristics

8.1 Absolute Maximum Ratings

Stresses in excess of the absolute maximum ratings can cause permanent damage to the device. These are absolute stress ratings only. Functional operation of the device is not implied at these or any other conditions in excess of those given in the operational sections of the data sheet. Exposure to absolute maximum ratings for extended periods can adversely affect device reliability.

External leads can be bonded and soldered safely at temperatures of up to 300 °C.

Voltage Range on any Pin with Respect to Ground.....	-0.5 V to +6 V
Power Dissipation	0.3 W
Ambient Temperature Range.....	-40 °C to +85 °C
Storage Temperature Range	-65 °C to +150 °C

8.2 Handling Precautions

All MOS devices must be handled with certain precautions to avoid damage due to the accumulation of static charge. Although input protection circuitry has been incorporated into the devices to minimize the effect of this static buildup, proper precautions should be taken to avoid exposure to electrostatic discharge during handling and mounting. Lucent Technologies employs a human-body model for ESD-susceptibility testing. Since the failure voltage of electronic devices is dependent on the current, voltage, and, hence, the resistance and capacitance, it is important that standard values be employed to establish a reference by which to compare test data. Values of 100 pF and 1500 Ω are the most common and are the values used in the Lucent human-body model test circuit. The breakdown voltage for the CSP1027 is greater than 1000 V.

8.3 Recommended Operating Conditions

Table 11. Recommended Operating Conditions

Parameter	Symbol	Min	Max	Unit
Analog Supply Voltage	VDDA	4.5	5.5	V
Digital Supply Voltage	VDD	2.7	5.5	V
Ambient Temperature	TA	-40	85	°C

8.3.1 Package Thermal Considerations

The recommended operating temperature specified above is based on the maximum power, package type, and maximum junction temperature. The following equation describes the relationship between these parameters. Certain applications' maximum power may be less than the worst-case value and can use this relationship to determine the maximum ambient temperature allowed.

$$T_A = T_J - P \times \Theta_{JA}$$

Maximum Junction Temperature (T _J) in 44-Pin QFP	125 °C
44-pin QFP Maximum Thermal Resistance in Still-Air-Ambient (Θ _{JA}).....	39 °C/W
Maximum Junction Temperature (T _J) in 48-Pin TQFP	125 °C
48-pin TQFP Maximum Thermal Resistance in Still-Air-Ambient (Θ _{JA})	90 °C/W

9 Electrical Characteristics and Requirements

The following electrical characteristics are preliminary and are subject to change. Electrical characteristics refer to the behavior of the device under specified conditions. Electrical requirements refer to conditions imposed on the user for proper operation of the device. The parameters below are valid for the following conditions:

$V_{DD} = 5\text{ V} \pm 10\%$ (See Section 8.3 on page 47 for exceptions.)

Table 12. Digital Electrical Characteristics and Requirements

Parameter	Symbol	Min	Max	Unit
Input Voltage (except PORCAP):				
Low	V_{IL}	—	$0.3 \times V_{DD}$	V
High	V_{IH}	$0.7 \times V_{DD}$	—	V
PORCAP Input Voltage:				
Low	V_{IL}	—	$0.5 \times V_{DD}$	V
High	V_{IH}	$0.7 \times V_{DD}$	—	V
Input Current (except EIGS, IOCK, PORCAP):				
Low ($V_{IL} = 0\text{ V}$)	I_{IL}	-5	—	μA
High ($V_{IH} = 5.5\text{ V}$)	I_{IH}	—	5	μA
Input Current (EIGS):				
Low ($V_{IL} = 0\text{ V}$)	I_{IL}	-5	—	μA
High ($V_{IH} = 5.5\text{ V}$)	I_{IH}	—	100	μA
Input Current (IOCK):				
Low ($V_{IL} = 0\text{ V}$)	I_{IL}	-100	—	μA
High ($V_{IH} = 5.5\text{ V}$)	I_{IH}	—	5	μA
Input Current (PORCAP):				
Low ($V_{IL} = 0\text{ V}$)	I_{IL}	-100	—	μA
High ($V_{IH} = 5.5\text{ V}$)	I_{IH}	—	5	μA
Output Low Voltage:				
Low ($I_{OL} = 2.0\text{ mA}$)	V_{OL}	—	0.4	V
Low ($I_{OL} = 50\ \mu\text{A}$)	V_{OL}	—	0.2	V
Output High Voltage:				
High ($I_{OH} = -2.0\text{ mA}$)	V_{OH}	$V_{DD} - 0.7$	—	V
High ($I_{OH} = -50\ \mu\text{A}$)	V_{OH}	$V_{DD} - 0.2$	—	V
Output 3-State Current:				
Low ($V_{DD} = 5.5\text{ V}$, $V_{IL} = 0\text{ V}$)	I_{OZL}	-10	—	μA
High ($V_{DD} = 5.5\text{ V}$, $V_{IH} = 5.5\text{ V}$)	I_{OZH}	—	10	μA
Input Capacitance	C_I	—	10	pF

9 Electrical Characteristics and Requirements (continued)

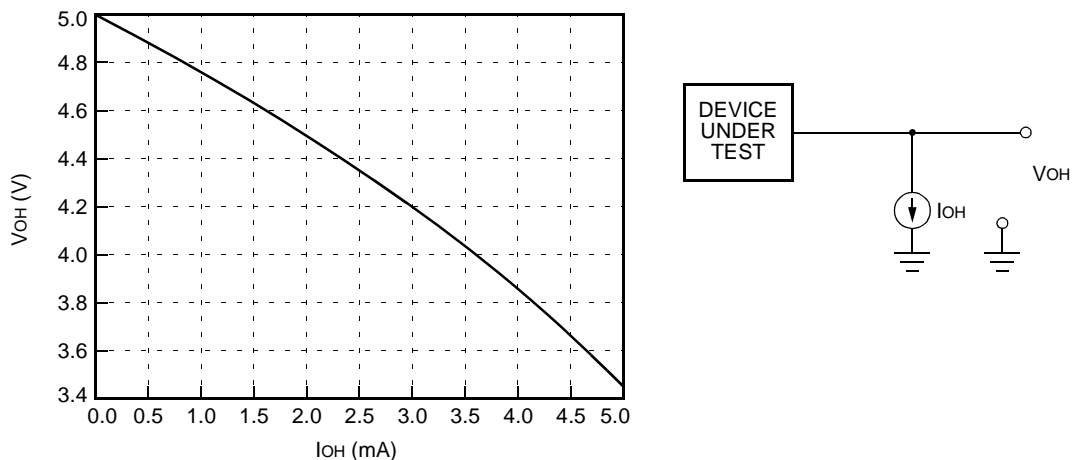

5-7616 (F)

Figure 37. Plot of V_{OH} vs. I_{OH} Under Typical Operating Conditions

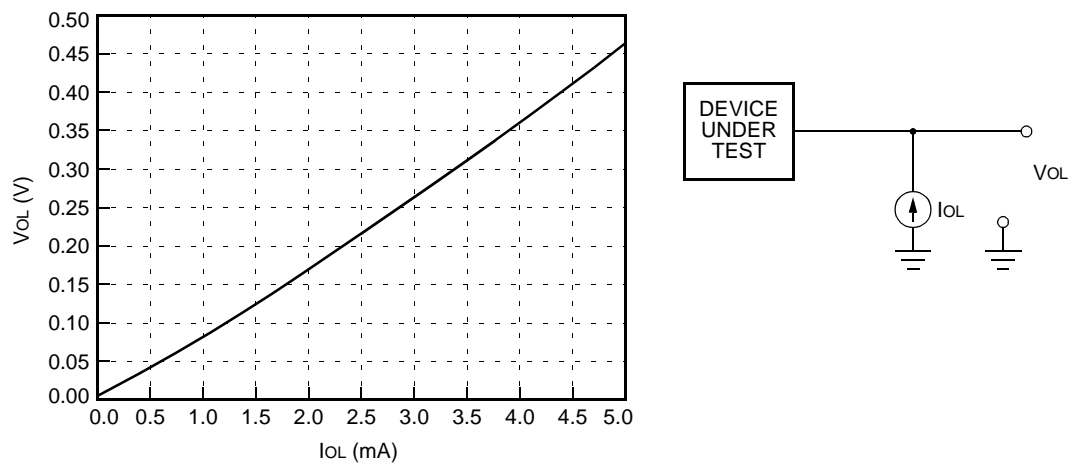

5-7617 (F)

Figure 38. Plot of V_{OL} vs. I_{OL} Under Typical Operating Conditions

9 Electrical Characteristics and Requirements (continued)

9.1 Power Dissipation

Power dissipation is highly dependent on the frequency of operation. The typical power dissipation listed is for a selected application. The following electrical characteristics are preliminary and are subject to change.

Table 13. Power Dissipation

Operating Mode	Analog Supply (V _{DDA})		Digital Supply (V _{DD})					
	5.0 V		5.0 V		3.3 V		3.0 V	
	Typ 5.0 V	Max 5.5 V	Typ 5.0 V	Max 5.5 V	Typ 3.3 V	Max 3.6 V	Typ 3.0 V	Max 3.3 V
Codec Active, Crystal Osc. Disabled (cioc0 : ACTIVE = 1, XOSCEN = 0, CLK at 25 MHz, IOCK at 6.25 MHz, CKos at 1 MHz)	11.0 mA 55.0 mW	12.2 mA 67.1 mW	4.6 mA 23.0 mW	5.8 mA 31.9 mW	3.0 mA 9.9 mW	3.8 mA 13.7 mW	2.8 mA 8.4 mW	3.5 mA 11.5 mW
Codec Inactive, Crystal Osc. Disabled (cioc0 : ACTIVE = 0, XOSCEN = 0, CLK at 25 MHz, IOCK at 6.25 MHz)	0.01 mA 0.05 mW	0.02 mA 0.11 mW	3.7 mA 18.5 mW	4.9 mA 26.9 mW	2.5 mA 8.2 mW	3.2 mA 11.5 mW	2.2 mA 6.6 mW	2.9 mA 9.6 mW
Codec Active, Crystal Osc. Enabled (cioc0 : ACTIVE = 1, XOSCEN = 1, 25 MHz crystal, IOCK at 6.25 MHz, CKos at 1 MHz)	11.0 mA 55.0 mW	12.2 mA 67.1 mW	10.2 mA 51.0 mW	11.4 mA 62.7 mW	4.1 mA 13.5 mW	5.0 mA 18.0 mW	3.9 mA 11.7 mW	4.7 mA 15.5 mW
Codec Inactive, Crystal Osc. Enabled (cioc0 : ACTIVE = 0, XOSCEN = 1, 25 MHz crystal, IOCK at 6.25 MHz)	0.01 mA 0.05 mW	0.02 mA 0.11 mW	9.3 mA 46.5 mW	10.5 mA 57.8 mW	3.6 mA 11.9 mW	4.4 mA 15.8 mW	3.3 mA 9.9 mW	4.1 mA 13.5 mW

The power dissipation listed is for internal power dissipation only. Total power dissipation can be calculated on the basis of the application by adding $C \times V_{DD}^2 \times f$ for each output, where C is the additional load capacitance and f is the effective output frequency.

Power dissipation due to the input and I/O buffers is highly dependent on the input voltage level. At full CMOS levels, essentially no dc current is drawn. However, for levels near the threshold of $0.5 \times V_{DD}$, high and unstable levels can flow. Therefore, all unused input pins should be tied inactive to V_{DD} or V_{SS}, and all unused I/O pins should be tied inactive through a 10 kΩ resistor to V_{DD} or V_{SS}. Table 13 shows the input buffer power dissipation for inputs at dc levels, V_{DD} or V_{SS}.

10 Analog Characteristics and Requirements

The following analog characteristics and requirements are preliminary information and are subject to change. Analog characteristics refer to the behavior of the device under specified conditions. Analog requirements refer to conditions imposed on the user for proper operation of the device. All analog data is valid for the following conditions unless otherwise specified:

- $T_A = -40\text{ }^\circ\text{C}$ to $+85\text{ }^\circ\text{C}$.
- $V_{DDA} = 5\text{ V} \pm 10\%$ (See Section 8.2 on page 47.)
- Sampling frequency = 8 kHz, oversampling clock (CKOs) = 1.0 MHz, input clock (CLK) = 25 MHz.
- 0.22 μF capacitors connected to the REFC pin.
- 0.15 μF coupling capacitors connected to the MICIN and AUXIN pins when EIGS = 0.
- $R_{fb} = R_{in} = 24\text{ k}\Omega$, $C_{fb} = 270\text{ pF}$, and $C_{in} = 1\text{ }\mu\text{F}$ when in the external input gain select mode (EIGS = 1).
- 2 $\text{k}\Omega$ differential output load connected between AOUTP and AOUTN pins.
- 1 μF and 0.1 μF bypass capacitors connected between the VREG and VSSA.
- 0 dBm0 is the level that corresponds to a sine wave that is 3.14 dB below the clipping (overload) level at the output of the A/D or input to the D/A.
- All noise and distortion measurements are flat weighted and integrated over the 300 Hz to 4 kHz frequency band.

10.1 Analog Input and Microphone Regulator

Table 14. Analog Input Characteristics and Requirements

Symbol	Parameter	Min	Typ	Max	Unit	
Rin	A/D Input Resistance of AUXIN and MICIN: EIGS = 0	40	—	—	$\text{k}\Omega$	
	EIGS = 1	1000	—	—	$\text{k}\Omega$	
Cin	A/D Input Capacitance on AUXIN and MICIN	—	—	20	μF	
—	A/D Input Clipping Level at AUXIN or MICIN: EIGS = 0, cioc0 : IRSEL = 0	0.490	0.500	0.510	Vp	
		EIGS = 0, cioc0 : IRSEL = 1	0.143	0.160	0.180	Vp
—	A/D Input Clipping Level at AUXIN: EIGS = 1	1.49	1.578	1.67	Vp	
—	Gain Referred to Nominal Clipping Level: EIGS = 0, cioc0 : IRSEL = 0	-0.18	0	0.18	dB	
		EIGS = 0, cioc0 : IRSEL = 1	-1.0	0	1.0	dB
		EIGS = 1	-0.5	0	0.5	dB

Note: The input clipping level corresponds to an A/D path output of 3.14 dBm0.

Table 15. Microphone Regulator Characteristics

Parameter	Min	Typ	Max	Unit
VREG Output Voltage	2.7	3.0	3.3	Vrms
VREG Output Current	—	—	250	μA
VREG Output Noise	—	—	100	μVrms

Note: VREG must be bypassed to analog ground through a 1 μF low ESR capacitor to meet this noise specification. The minimum bypass capacitance for stable VREG operation is 0.1 μF , with a maximum noise of 200 μVrms .

10 Analog Characteristics and Requirements (continued)

10.2 Analog-to-Digital Path

Table 16. A/D Signal to Distortion Plus Noise Ratio

Output Signal Level	Preamp (EIGS = 0) 0.5 Vp Range (cioc0: IRSEL = 0)		Preamp (EIGS = 0) 0.16 Vp Range (cioc0: IRSEL = 1)		Ext. Gain Select (EIGS = 1) 1.578 Vp Range		Unit
	Min	Max	Min	Max	Min	Max	
0 dBm0	71	—	68	—	71	—	dB
-10 dBm0	62	—	59	—	62	—	dB
-30 dBm0	42	—	39	—	42	—	dB
-40 dBm0	32	—	29	—	32	—	dB
-45 dBm0	27	—	24	—	27	—	dB
-55 dBm0	17	—	14	—	17	—	dB

Notes:

The signal to distortion plus noise ratio is from the MICIN or AUXIN input to the PCM output when EIGS = 0, and from Vin (of Figure 5 on page 7) to PCM output when EIGS = 1.

The A/D signal to distortion plus noise ratio is valid for sampling rates up to 16 kHz. For sampling rates between 16 kHz and 24 kHz, the signal to distortion plus noise ratio is no better than 60 dB.

Table 17. A/D Relative Gain Accuracy*

Output Signal Level	Min	Max	Unit
+3 dBm0 to -40 dBm0	-0.1	0.1	dB
-40 dBm0 to -50 dBm0	-0.4	0.4	dB
-50 dBm0 to -55 dBm0	-1.2	1.2	dB

* Gain is relative to the 0 dBm0 signal level with EIGS = 0 and IRSEL = 0.

Table 18. A/D Frequency Response Relative to 1 kHz Output Level (fos = 1 MHz and fs = 8 kHz)

Frequency	High-Pass Filter Enabled (HPFE = 0)		High-Pass Filter Disabled (HPFE = 1)		Unit
	Min	Max	Min	Max	
50 Hz	—	-40	-0.25	0.25	dB
60 Hz	—	-40	-0.25	0.25	dB
100 Hz	-34	-18	-0.25	0.25	dB
200 Hz	-12	0	-0.25	0.25	dB
300 Hz	-0.25	0.25	-0.25	0.25	dB
3000 Hz	-0.25	0.25	-0.4	0.25	dB
3400 Hz	-0.9	0.25	-0.9	0.25	dB
4000 Hz	—	-6	—	-6	dB
4600 Hz	—	-35	—	-35	dB
8000 Hz	—	-45	—	-45	dB

Note: The frequency response scales linearly with codec oversampling clock rate. Frequencies greater than 4000 Hz are affected by antialias filtering attenuation.

10 Analog Characteristics and Requirements (continued)

10.3 Digital-to-Analog Path

Table 19. D/A Signal to Distortion Plus Noise Ratio (0 dB Output Setting)

Output Signal Level	Min	Max	Unit
0 dBm0	72	—	dB
-10 dBm0	62	—	dB
-30 dBm0	42	—	dB
-40 dBm0	32	—	dB
-45 dBm0	27	—	dB
-55 dBm0	17	—	dB

Notes:

The D/A signal to distortion plus noise ratio decreases by 3 dB for each 3 dB gain step below 0 dB. The D/A SDNR is specified with a differential load. For a single-ended load, the D/A SDNR is degraded by about 6 dB.

The D/A signal to distortion plus noise ratio is valid for sampling rates up to 16 kHz. For sampling rates between 16 kHz and 24 kHz, the signal to distortion plus noise ratio is no better than 60 dB.

Table 20. D/A Relative Gain Accuracy*

Output Signal Level	Min	Max	Unit
+3 dBm0 to -40 dBm0	-0.1	0.1	dB
-40 dBm0 to -50 dBm0	-0.4	0.4	dB
-50 dBm0 to -55 dBm0	-1.2	1.2	dB

* Gain is relative to the 0 dBm0 signal level. Absolute gain accuracy at the 0 dBm0 signal level is ± 0.18 dB. Digital-to-analog path gain is specified with a differential load; a single-ended load adds ± 0.1 dB to absolute gain.

Table 21. D/A Output Gain Adjustment

Gain Setting	Min	Typ	Max	Unit
0 dB	-0.2	0	0.2	dB
-3 dB	-3.21	-3.01	-2.81	dB
-6 dB	-6.22	-6.02	-5.82	dB
-9 dB	-9.23	-9.03	-8.83	dB
-12 dB	-12.24	-12.04	-11.84	dB
.
.
.
-42 dB	-42.34	-42.14	-41.94	dB
-45 dB	-45.35	-45.15	-44.95	dB

10 Analog Characteristics and Requirements (continued)

Table 22. D/A Frequency Response Relative to 1 kHz Output Level (fos = 1 MHz and fs = 8 kHz)

Frequency	High-Pass Filter Enabled (HPFE = 0)		High-Pass Filter Disabled (HPFE = 1)		Unit
	Min	Max	Min	Max	
50 Hz	—	-40	-0.25	0.25	dB
60 Hz	—	-40	-0.25	0.25	dB
100 Hz	-34	-18	-0.25	0.25	dB
200 Hz	-12	0	-0.25	0.25	dB
300 Hz	-0.25	0.25	-0.25	0.25	dB
3000 Hz	-0.25	0.25	-0.25	0.25	dB
3400 Hz	-0.9	0.25	-0.9	0.25	dB
4000 Hz	—	-6	—	-6	dB
4600 Hz	—	-35	—	-35	dB
8000 Hz	—	-45	—	-45	dB

10.4 Miscellaneous

Table 23. Other Analog Characteristics and Requirements*

Parameter	Min	Max	Unit
D/A Differential Output Resistance (0 kHz to 4 kHz)	—	12	Ω
D/A Single-ended Output Resistance (0 kHz to 4 kHz)	—	6	Ω
Analog-to-Digital Power Supply Rejection Ratio at 3 kHz	30	—	dB
Digital-to-Analog Power Supply Rejection Ratio at 3 kHz	40	—	dB
Analog Input Coupling Capacitor Input Leakage Current	—	30	nA
Idle Channel Noise at Analog-to-Digital Output with Input Gain Setting of 500 mVp or 160 mVp	—	-65	dBm0
Idle Channel Noise at Digital-to-Analog Output	—	300	μ Vrms
A/D to D/A and D/A to A/D Crosstalk	—	-65	dB
Digital-to-Analog Image Frequency Attenuation Above 4600 Hz	35	—	dB
Digital-to-Analog Output Amplifier Differential Swing for 2 k Ω Load	—	1.5	Vrms
Codec Filter Group Delay for Frequencies Less than 800 Hz	—	2.8	ms
Codec Filter Group Delay for Frequencies Greater than 800 Hz	—	0.8	ms
Recovery Time of Digital-to-Analog Output Due to a Change from Inactive Mode to Active Mode, Muted to Not Muted, or Change in Output Gain (See cioc0 register, ACTIVE, MUTE, OGSEL.)	—	100	ms
Recovery Time of Analog-to-Digital PCM Output and VREG Due to a Change from Inactive Mode to Active Mode (See cioc0 register, ACTIVE.)	—	600	ms
Recovery Time of Analog Circuits Due to a Change in Input Select or Input Range (See cioc0 register, INSEL and IRSEL.)	—	100	ms
Allowable CLK Input Jitter	-5	5	ns
Allowable CLK Frequency Error	-1	1	%

* The codec is intended to drive a floating 2 k Ω load, such as a telephone handset speaker, or 1 k Ω loads ac-coupled to ground on both analog outputs. Since the codec outputs AOUTP and AOUTN have common-mode dc voltage, ac coupling must be used if there is a dc path to VDD or VSS (ground) through the load.

11 Timing Characteristics and Requirements

The following timing characteristics and requirements are preliminary information and are subject to change. Timing characteristics refer to the behavior of the device under specified conditions. Timing requirements refer to conditions imposed on the user for proper operation of the device. All timing data is valid for the following conditions:

$T_A = -40\text{ }^\circ\text{C}$ to $+85\text{ }^\circ\text{C}$ or $0\text{ }^\circ\text{C}$ to $70\text{ }^\circ\text{C}$ (See Section 8.2 on page 47.)

$V_{DD} = 5\text{ V} \pm 0.5\text{ V}$, $3.3\text{ V} \pm 0.3\text{ V}$, or $3.0\text{ V} \pm 0.3\text{ V}$, $V_{SS} = 0\text{ V}$ (See Section 8.2 on page 47.)

Capacitance load on outputs (C_L) = 50 pF

Output characteristics can be derated as a function of load capacitance (C_L).

All outputs: $dt/dC_L \leq 0.06\text{ ns/pF}$ for $0 \leq C_L \leq 100\text{ pF}$ at V_{IH} for rising edge

$dt/dC_L \leq 0.05\text{ ns/pF}$ for $0 \leq C_L \leq 100\text{ pF}$ at V_{IL} for falling edge

For example, if the actual load capacitance is 30 pF instead of 50 pF, the derating for a rising edge is $(30\text{ pF} - 50\text{ pF}) \times 0.06\text{ ns/pF} = 1.2\text{ ns}$ **less** than the specified rise time or delay which includes a rise time.

Test conditions for inputs:

- Rise and fall times of 4 ns or less
- Timing reference levels for delays = V_{IH} , V_{IL}

Test conditions for outputs:

- $C_{LOAD} = 50\text{ pF}$
- Timing reference levels for delays = V_{IH} , V_{IL}
- 3-state delays measured to the high-impedance state of the output driver

11 Timing Characteristics and Requirements (continued)

11.1 Clock Generation

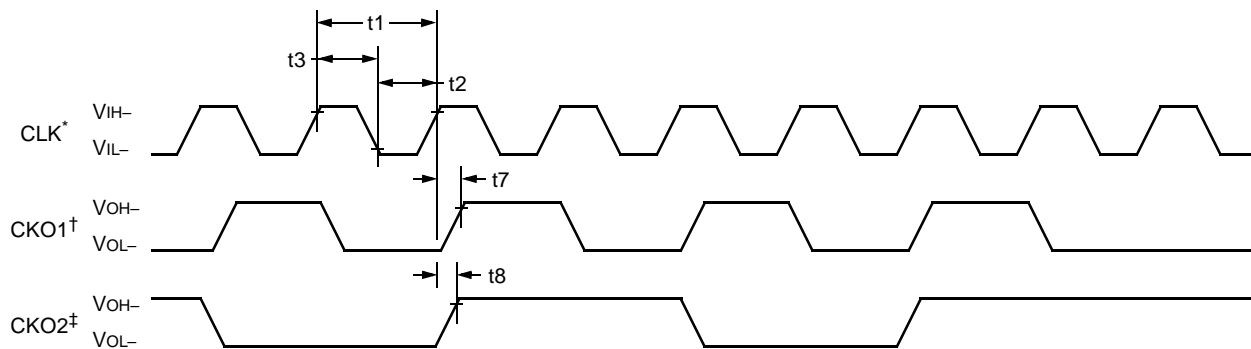

5-7618 (F)

* OSCEN = 0 shown.

† CDIV0 = 2, CDIV1 = 1 configuration shown (see Table 8 on page 27).

‡ CDIV2 = 4 option shown (see Table 8 on page 27).

Figure 39. Clock Timing Diagram

Table 24. Timing Requirements for Input Clock

Abbreviated Reference	Parameter	5.0 V		3.3 V		3.0 V		Unit
		Min	Max	Min	Max	Min	Max	
t1	Clock In Period (high to high)	25	—*	42	—*	60	—*	ns
t2	Clock In Low Time (low to change)	11	—	19	—	27	—	ns
t3	Clock In High Time (high to change)	11	—	19	—	27	—	ns

* Device is fully static, t1 is tested at 500 ns.

Table 25. Timing Characteristics for Output Clocks

Abbreviated Reference	Parameter	5.0 V		3.3 V		3.0 V		Unit
		Min	Max	Min	Max	Min	Max	
t7	Clock Out 1 Delay (valid to valid)	—	30	—	54	—	66	ns
t8	Clock Out 2 Delay (valid to valid)	—	20	—	40	—	50	ns

11 Timing Characteristics and Requirements (continued)

11.2 Power-On Reset

The CSP1027 has a power-on reset circuit that automatically clears the device upon power-on. If the supply voltage falls below $V_{DD\ MIN}^*$, the device must be reset. Figure 40 on page 57 shows two separate events: an initial power-on and a power-on following a drop in the power supply.

* See Table 11 on page 47.

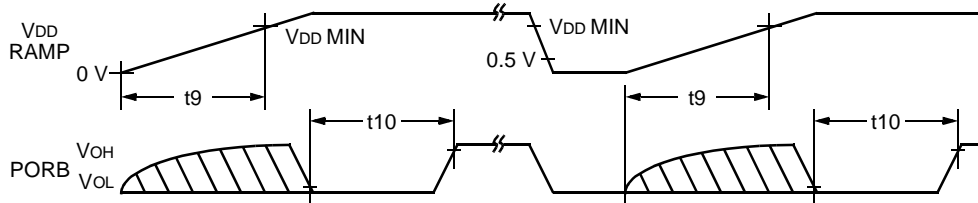

5-7619 (F)

Figure 40. Power-On Reset Timing Diagram

Table 26. Timing Requirement for Power-On Reset

Abbreviated Reference	Parameter	Min	Max	Unit
t9	VDD Ramp	—	1	ms

Table 27. Timing Characteristic for Power-On Reset

Abbreviated Reference	Parameter	Min	Max	Unit
t10	PORB Pulse Width (low to change)	1.5	7	ms

Note: The device needs to be clocked for at least six CLK cycles during reset after power-on. Otherwise, high and unstable current may flow.

11 Timing Characteristics and Requirements (continued)

11.3 Reset

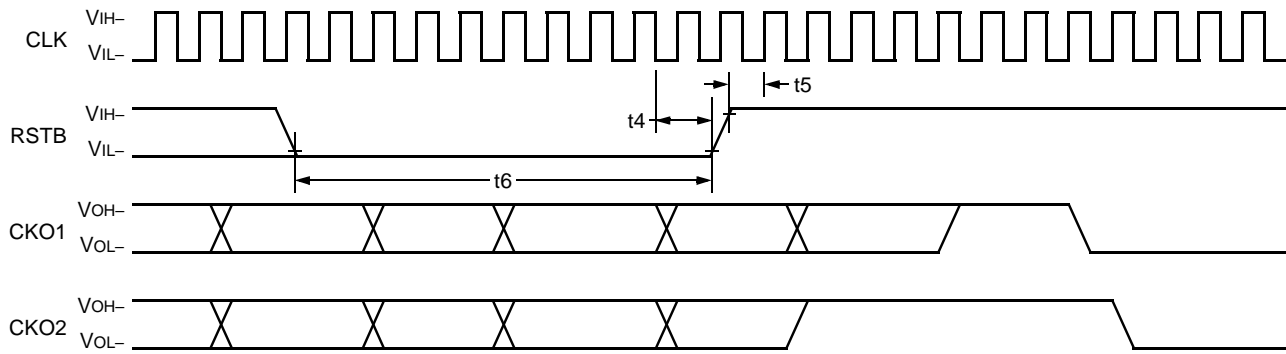

5-7620 (F)

Note: CKO1 and CKO2 are active during reset and synchronized by the rising edge of reset.

Figure 41. Reset Timing

Table 28. Timing Requirements for Reset Timing

Abbreviated Reference	Parameter	Min	Max	Unit
t4	Reset Hold (high to change)	2	—	ns
t5	Reset Setup (valid to high)	4	—	ns
t6	Reset Pulse (low to high)	6T	—	ns

11 Timing Characteristics and Requirements (continued)

11.4 Serial I/O Communication

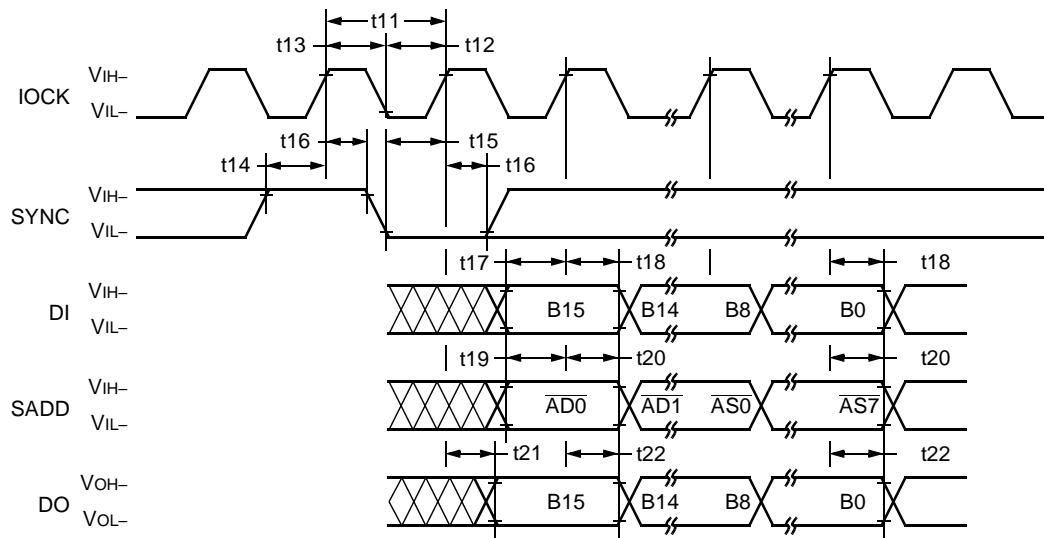

5-7621 (F)

Figure 42. Serial Input/Output Timing Diagram

Table 29. Timing Requirements for Serial Input/Output

Abbreviated Reference	Parameter	5.0 V		3.3 V		3.0 V		Unit
		Min	Max	Min	Max	Min	Max	
t11	Clock Period (high to high)	50	—*	84	—*	120	—*	ns
t12	Clock Low Time (low to change)	20	—	33	—	48	—	ns
t13	Clock High Time (high to change)	20	—	33	—	48	—	ns
t14	Sync High Setup (high to high)	6	—	11	—	13	—	ns
t15	Sync Low Setup (low to high)	9	—	15	—	20	—	ns
t16	Sync Hold (high to invalid)	0	—	0	—	0	—	ns
t17	Data Setup (valid to high)	6	—	11	—	13	—	ns
t18	Data Hold (high to invalid)	0	—	0	—	0	—	ns
t19	Address Setup (valid to high)	9	—	15	—	20	—	ns
t20	Address Hold (high to invalid)	0	—	0	—	0	—	ns

* Device is fully static; t11 is tested at 100 ns. The frequency of IOCK must be greater than the frequency of the internal oversampling clock CKOS (Fckos).

Table 30. Timing Characteristics for Serial Input/Output

Abbreviated Reference	Parameter	5.0 V		3.3 V		3.0 V		Unit
		Min	Max	Min	Max	Min	Max	
t21	Data/Status Delay (high to valid)	—	26	—	50	—	57	ns
t22	Data/Status Hold (high to invalid)	2	—	2	—	2	—	ns

11 Timing Characteristics and Requirements (continued)

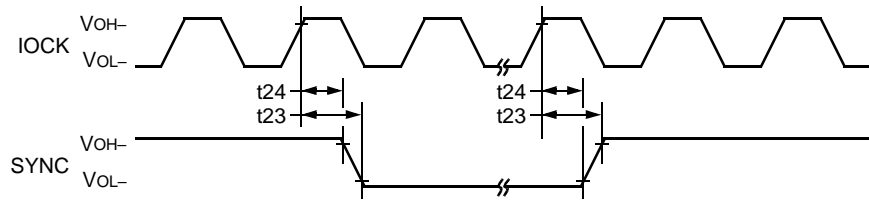

5-7622 (F)

Figure 43. Serial I/O Active Mode Timing Diagram

Table 31. Timing Characteristics for Active Mode

Abbreviated Reference	Parameter	5.0 V		3.3 V		3.0 V		Unit
		Min	Max	Min	Max	Min	Max	
t23	Sync Delay (high to valid)	—	26	—	50	—	55	ns
t24	Sync Hold (high to invalid)	2	—	2	—	2	—	ns

11 Timing Characteristics and Requirements (continued)

11.5 Serial Multiprocessor Communication

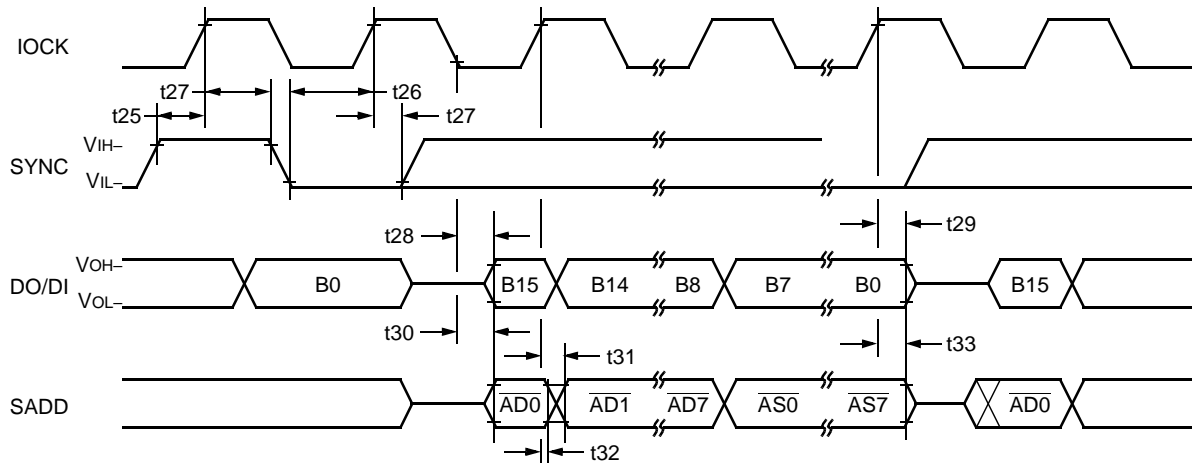

5-7623 (F)

Figure 44. SIO Multiprocessor Timing Diagram

Table 32. Timing Requirements for Multiprocessor Communication

Abbreviated Reference	Parameter	5.0 V		3.3 V		3.0 V		Unit
		Min	Max	Min	Max	Min	Max	
t25	Sync High Setup (high to high)	10	—	16	—	23	—	ns
t26	Sync Low Setup (low to high)	22	—	35	—	44	—	ns
t27	Sync Hold (high to invalid)	2	—	0	—	0	—	ns

Table 33. Timing Characteristics for Multiprocessor Communication

Abbreviated Reference	Parameter	5.0 V		3.3 V		3.0 V		Unit
		Min	Max	Min	Max	Min	Max	
t28	Data Delay (bit 0 only) (low to valid)	—	24	—	48	—	55	ns
t29	Data Disable Delay (high to 3-state)	—	18	—	26	—	35	ns
t30	Address Delay (bit 0 only) (low to valid)	—	26	—	50	—	57	ns
t31	Address Delay (high to valid)	—	22	—	40	—	48	ns
t32	Address Hold (low to valid)	2	—	2	—	2	—	ns
t33	Address Disable Delay (high to 3-state)	—	18	—	28	—	35	ns

Note: Capacitance load on DO, SYNC, and SADD = 100 pF.

12 Outline Diagrams

12.1 44-Pin EIAJ Quad Flat Pack (QFP)

Controlling dimensions are in millimeters.

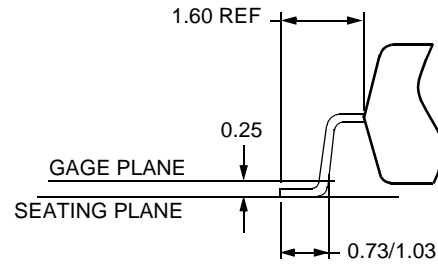
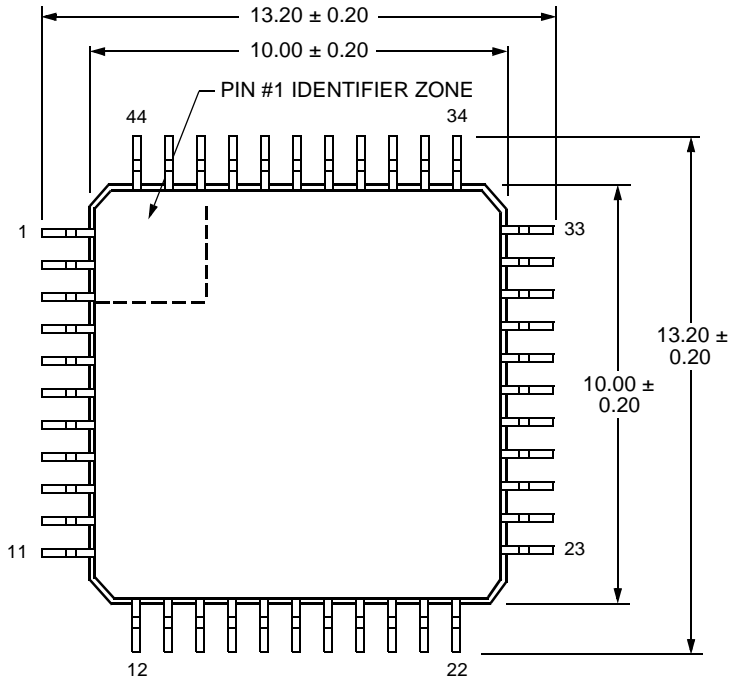

DETAIL A

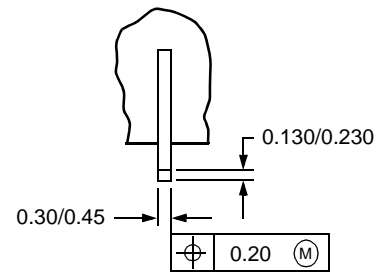

DETAIL B

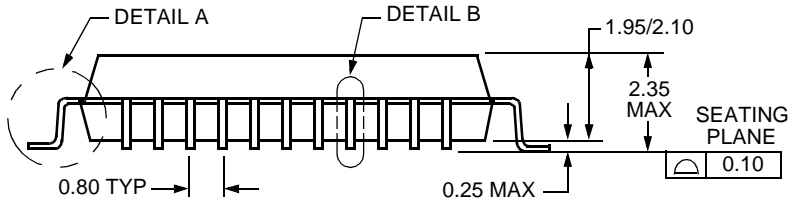

5-2111 (F) r.12

Note: The production line has been qualified at Lucent-SGP for this outline; also second-source (Shinko) tolerances have been accommodated on the above diagram.

For additional information, contact your Microelectronics Group Account Manager or the following:

INTERNET: <http://www.lucent.com/micro>

E-MAIL: docmaster@micro.lucent.com

N. AMERICA: Microelectronics Group, Lucent Technologies Inc., 555 Union Boulevard, Room 30L-15P-BA, Allentown, PA 18103
1-800-372-2447, FAX 610-712-4106 (In CANADA: **1-800-553-2448**, FAX 610-712-4106)

ASIA PACIFIC: Microelectronics Group, Lucent Technologies Singapore Pte. Ltd., 77 Science Park Drive, #03-18 Cintech III, Singapore 118256
Tel. (65) 778 8833, FAX (65) 777 7495

CHINA: Microelectronics Group, Lucent Technologies (China) Co., Ltd., A-F2, 23/F, Zao Fong Universe Building, 1800 Zhong Shan Xi Road, Shanghai 200233 P. R. China **Tel. (86) 21 6440 0468, ext. 316**, FAX (86) 21 6440 0652

JAPAN: Microelectronics Group, Lucent Technologies Japan Ltd., 7-18, Higashi-Gotanda 2-chome, Shinagawa-ku, Tokyo 141, Japan
Tel. (81) 3 5421 1600, FAX (81) 3 5421 1700

EUROPE: Data Requests: MICROELECTRONICS GROUP DATALINE: **Tel. (44) 7000 582 368**, FAX (44) 1189 328 148

Technical Inquiries: GERMANY: **(49) 89 95086 0** (Munich), UNITED KINGDOM: **(44) 1344 865 900** (Ascot),
FRANCE: **(33) 1 40 83 68 00** (Paris), SWEDEN: **(46) 8 594 607 00** (Stockholm), FINLAND: **(358) 9 4354 2800** (Helsinki),
ITALY: **(39) 02 6608131** (Milan), SPAIN: **(34) 1 807 1441** (Madrid)

Lucent Technologies Inc. reserves the right to make changes to the product(s) or information contained herein without notice. No liability is assumed as a result of their use or application. No rights under any patent accompany the sale of any such product(s) or information.

