



VX-505

### Features

- AT-Cut Crystal
- Surface Mount FR4 based package
- Reflow Process Compatible
- Extended temperature range -55..+125°C
- Low Phase Noise
- Tight Stabilities
- Frequency Range 20 - 800MHz
- Standard Frequencies 20; 30,72; 32,768; 38,88; 44,8; 61,44; 76,8; 77,76; 81,92; 92,16; 100; 112; 122,88; 125; 134,4; 153,6; 155,52; 160; 179,2; 184,32; 195; 208; 245,76; 320; 368,64; 400; 448; 491,52; 640; 672; 737,28; 800MHz

### Applications

- Communication
- Industrial
- Harsh Environmental
- Military

## Performance Specifications

Parameter	Frequency Stabilities <sup>1</sup>				Condition <sup>2</sup>
	Min	Typical	Max	Units	
vs. operating temperature range (referenced to +25°C)	-45		+45	ppm	-55 to +125°C
Initial tolerance	-30		+30	ppm	@V <sub>c</sub> =V <sub>s</sub> /2 V <sub>s</sub> ±5% Load ±10%
vs. supply voltage change	-2		+2	ppm	
vs. load change	-1		+1	ppm	
vs. aging / 20 Years	-8		+8	ppm	

## Performance Specifications

Supply Voltage (Vs)						
Parameter	Min	Typical	Max	Units	Condition <sup>2</sup>	
Supply voltage (standard)	3.135	3.3	3.465	VDC		Options <sup>5</sup>
Current consumption			40	mA	@ HCMOS	
Current consumption			90	mA	@ PECL	
Supply voltage	4.75	5	5.25	VDC		
Current consumption			30	mA	@ HCMOS	
Current consumption			80	mA	@ PECL	
RF Output						
Signal	HCMOS					Options <sup>5</sup>
Load		15		pF		
Rise and Fall time			5	ns	@ 15 pF 10 to 90%	
Duty cycle	40		60	%	@ Vs / 2	
Signal	PECL					
Load		50		Ω		
Rise and Fall time			1	ns	20 to 80%	
Duty cycle	45		55	%		
Frequency Tuning (EFC)						
Tuning Range	±60.0		±200.0	ppm		
Linearity	10 %					
Tuning Slope	Positive					
Control Voltage Range	0 0.5	1.65 2.5	3.3 4.5	VDC VDC	with Vs = 3.3V with Vs = 5V	
Frequency Control Input Impedance	2			MΩ		
Additional Parameters						
Phase Noise		-76 -112 -138 -153 -161 -166		dBc/Hz dBc/Hz dBc/Hz dBc/Hz dBc/Hz dBc/Hz	10 Hz 100 Hz 1 kHz 10 kHz 100 kHz 1 MHz	@100MHz LVCMOS 3.3V
Jitter		0.049		ps RMS	@ 12kHz .. 20MHz	
Phase Noise		-75 -105 -130 -145 -153		dBc/Hz dBc/Hz dBc/Hz dBc/Hz dBc/Hz	10 Hz 100 Hz 1 kHz 10 kHz 100 kHz	@ 153.6 MHz PECL 3.3V
Jitter		0.1		ps RMS	@ 12kHz .. 20MHz	
Phase Noise		-60 -95 -121 -141 -150		dBc/Hz dBc/Hz dBc/Hz dBc/Hz dBc/Hz	10 Hz 100 Hz 1 kHz 10 kHz 100 kHz	@ 491.52 MHz PECL 3.3V
Jitter		0.03		ps RMS	@ 12kHz .. 20MHz	

# Performance Specifications

## Additional Parameters

Subharmonics		-40	dBc	For f > 200 MHz
Weight		2.0 g		
Processing & Packing	Handling & Processing Note			
<b>Absolute Maximum Ratings</b>				
Supply voltage (Vs)		6.0	V	
Operable Temperature Range	-55	+125	°C	
Storage Temperature Range	-55	+125	°C	

## Typical Phase Noise and Jitter

### Phase Noise

VX-501 @ 100 MHz LVCMOS

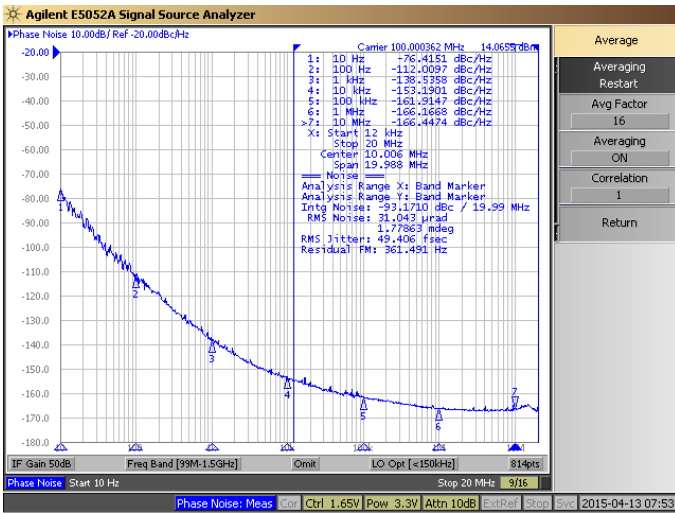

### Phase Noise

VX-501 @ 153.6 MHz LVPECL

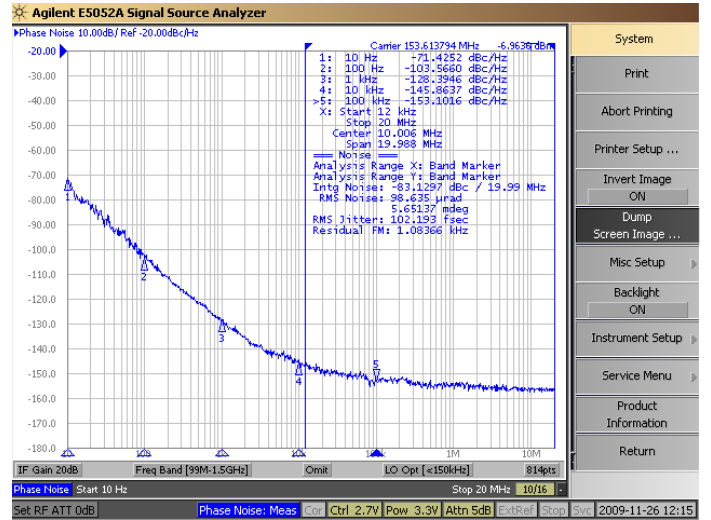

### Phase Noise

VX-501 @ 491.52 MHz LVPECL

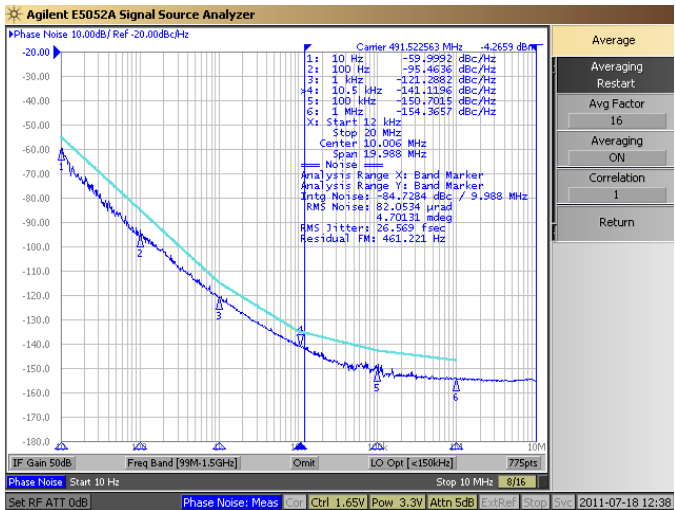

# Enclosure

## Package Codes

Type	Height "H"
G218C	2.8

G 218

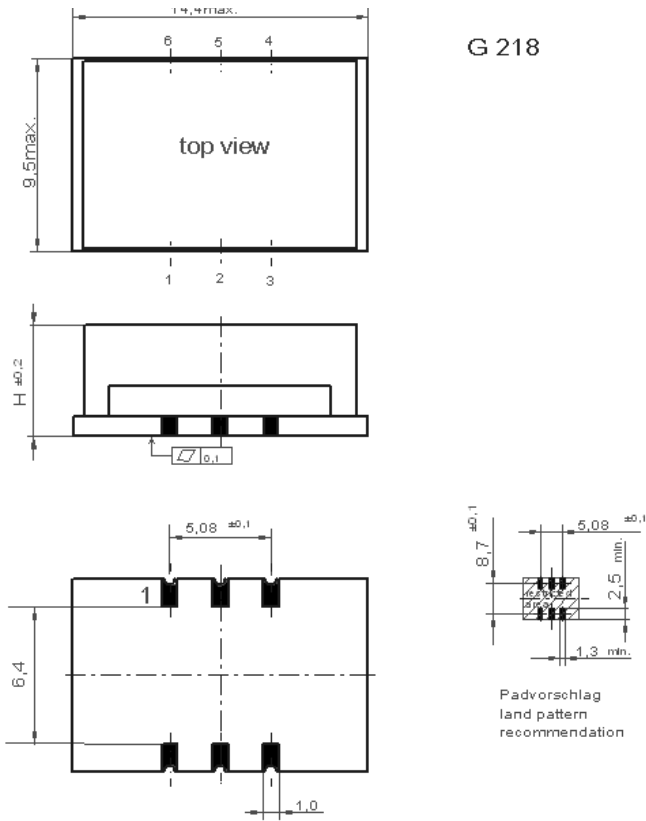

## Pin Connections

1	Control Voltage (Vc)
2	N.C. / Enable (Option)
3	Ground
4	RF Output
5	RF Output complementary (PECL) N.C. (CMOS)
6	Supply Voltage Input (Vs)

## Marking

VX-505-xxxx
Frequency
● AYYWW

## Enable true table (optional)

	HCMOS		LVPECL	
	Pin 4	Pin 5	Pin 4	Pin 5
Pin 2	Pin 4	Pin 5	Pin 4	Pin 5
High	Data	N.C.	No Data	No Data
Open	Data	N.C.	Data	Compl. Data
Low	High Tristate	N.C.	Data	Compl. Data

# Standard Shipping Method

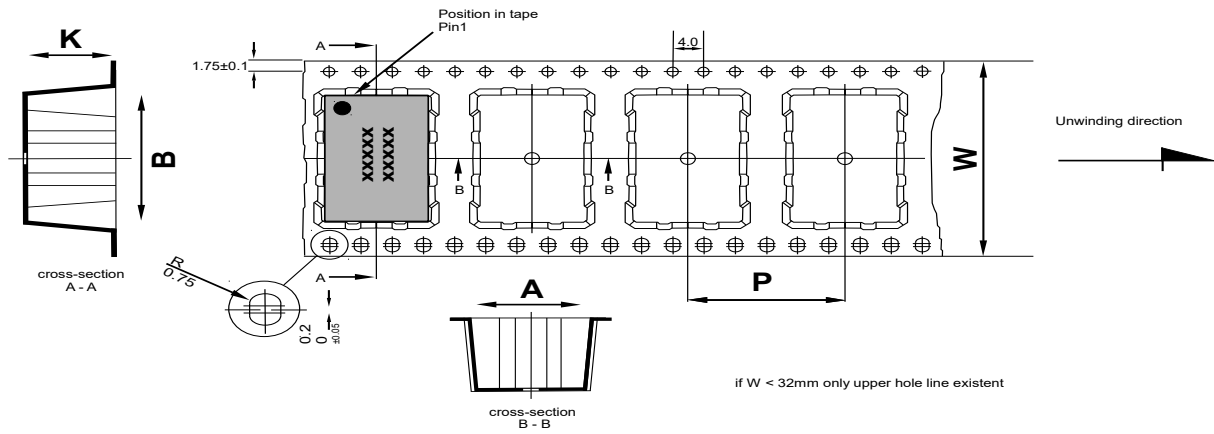

Dimension in mm:  
 A, B and K are dependent upon component dimensions  
 production tolerance complying DIN IEC 286-3

All dimensions in millimeters unless otherwise stated

Enclosure Type	Tape Width W (mm)	Quantity per meter	Quantity per reel	Dimension P
G218C	24	83.3	1700	12

# Recommended Reflow Profile

TP: max 250°C (@ solder joint, customer board level)

$T_p$ : max: 10...30 sec

Additional Information:

This SMD oscillator has been designed for pick and place reflow soldering

SMD oscillators must be on the top side of the PCB during the reflow process.

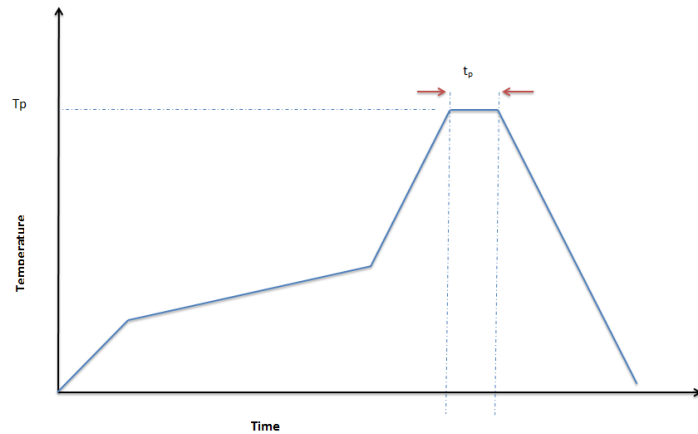

## Ordering Information

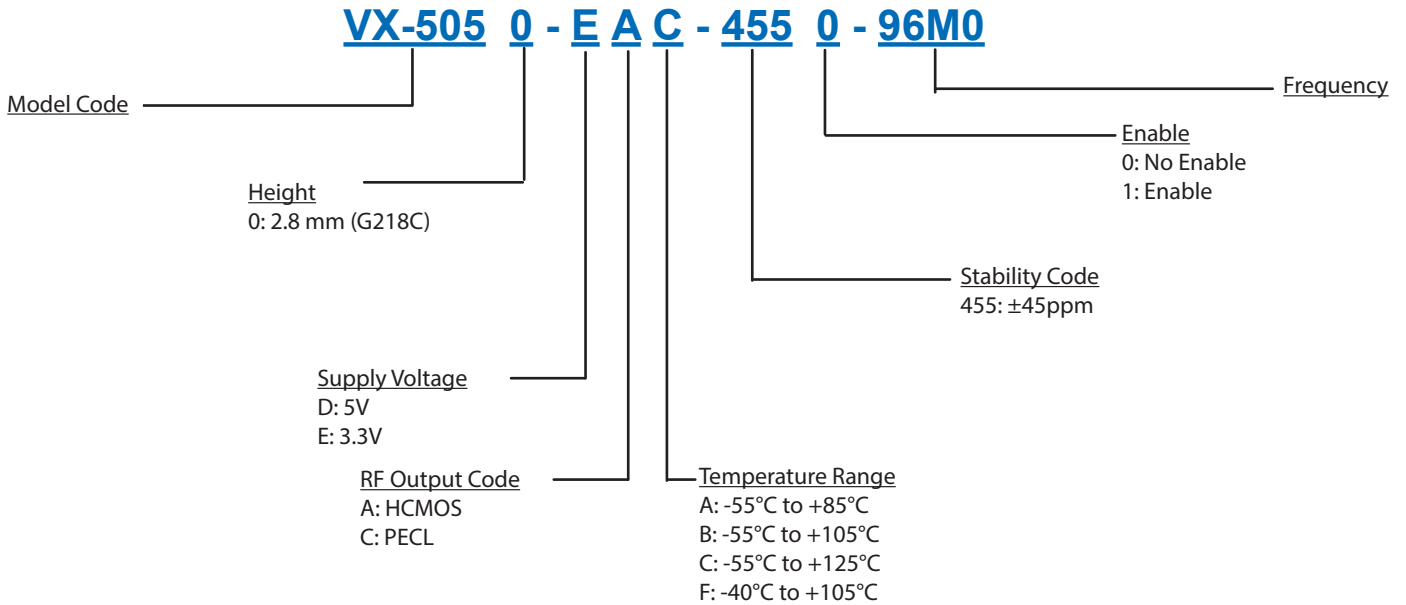

### Notes:

1. Contact factory for improved stabilities or additional product options. Not all options and codes are available at all frequencies.
2. Unless other stated all values are valid after warm-up time and refer to typical conditions for supply voltage, frequency control voltage, load, temperature (25°C).
3. Phase noise degrades with increasing output frequency.
4. Subject to technical modification.
5. Contact factory for availability.

## Contact Information

### USA:

100 Watts Street  
Mt Holly Springs, PA 17065  
Tel: 1.717.486.3411  
Fax: 1.717.486.5920

### Europe:

Landstrasse  
74924 Neckarbischofsheim  
Germany  
Tel: +49 (0) 7268.801.0  
Fax: +49 (0) 7268.801.281



Information contained in this publication regarding device applications and the like is provided only for your convenience and may be superseded by updates. It is your responsibility to ensure that your application meets with your specifications. MICROCHIP MAKES NO REPRESENTATION OR WARRANTIES OF ANY KIND WHETHER EXPRESS OR IMPLIED, WRITTEN OR ORAL, STATUTORY OR OTHERWISE, RELATED TO THE INFORMATION INCLUDING, BUT NOT LIMITED TO ITS CONDITION, QUALITY, PERFORMANCE, MERCHANTABILITY OR FITNESS FOR PURPOSE. Microchip disclaims all liability arising from this information and its use. Use of Microchip devices in life support and/or safety applications is entirely at the buyer's risk, and the buyer agrees to defend, indemnify and hold harmless Microchip from any and all damages, claims, suits, or expenses resulting from such use. No licenses are conveyed, implicitly, or otherwise, under any Microchip intellectual property rights unless otherwise stated.

### Trademarks

The Microchip and Vectron names and logos are registered trademarks of Microchip Technology Incorporated in the U.S.A. and other countries.