

GSD

751-20-7

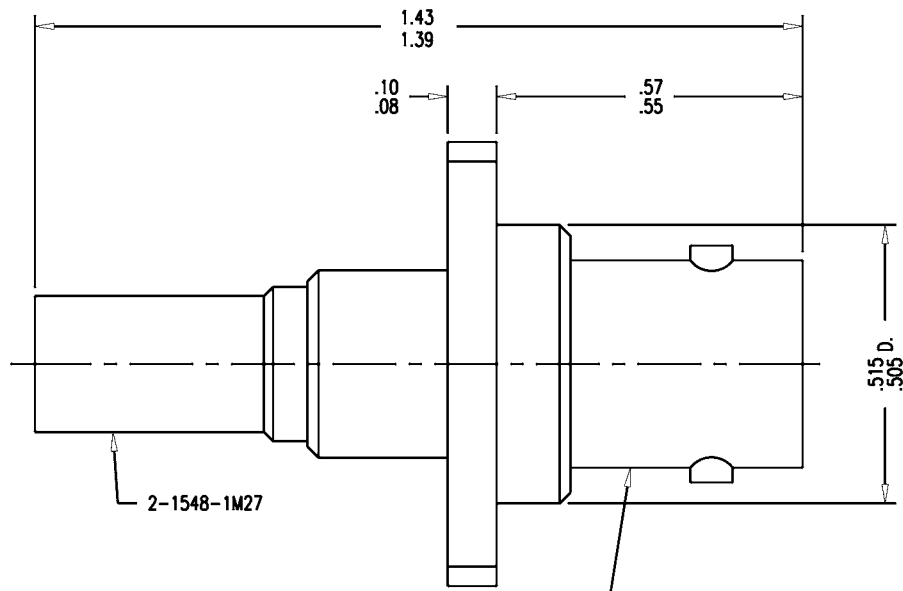

STAMP: KINGS 751-20-7
YRWK(DATECODE) 91836

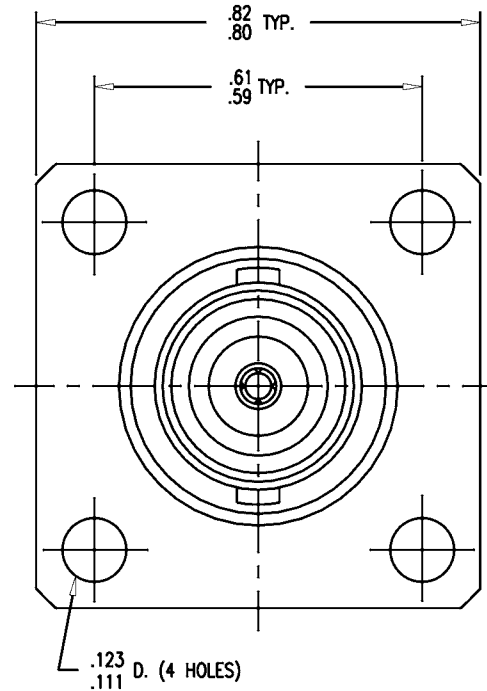

NOTES:

1. FOR USE WITH McDONNELL DOUGLAS HELICOPTER SYSTEMS CABLE HS5965-1 (BOEING S280W503-3 & ADAMS RUSSELL FC20Z CABLES).
2. FOR CABLING INSTRUCTIONS SEE 3-546-1.
3. FOR CRIMPING USE DIE KTH-2216.
4. INTERFACE PER MIL-STD-348, FIG. 301-2.
5. FOR USE WITH .140 MAX. PANEL.
6. CENTER CONTACT (1-507-40MA9) SUPPLIED UNASSEMBLED.
7. MARK PACKAGE: HS5939-4
KINGS 751-20-7
91836
YRWK (DATE CODE)
8. MATERIALS:
INSULATOR: TEFLON, ASTM-D-4894
CONTACT: BER. COP., ASTM-B-196
K-GRIP SLEEVE: COMMERCIAL BRONZE, ASTM-B-140
ALL OTHER PARTS: BRASS, ASTM-B16
9. FINISHES:
CONTACT: GOLD PLATE PER MIL-G-45204
ALL OTHER METAL PARTS: KINGS TARNISH RESISTANT NICKEL FINISH (TR-5)
10. ELECTRICAL CHARACTERISTICS:
NOMINAL IMPEDANCE: 50 OHMS
VOLTAGE RATING: 500 VRMS
FREQUENCY RANGE: DC TO 4 GHz

REVISIONS

ISSUE	CHANGES
0	ER 38937 DCT 9/26/3

SCALE	4:1		
APPROX SURFACE AREA			
WAS:			
USED ON			
REF:	HS5939-4 REV. -		
JACK, PANEL, BNC			
DRAWN	DCT	DATE	9/26/3
DESIGN	JT	DATE	03/16/94
APPR.		DATE	

KINGS
ELECTRONICS CO., INC.
ROCK HILL, SOUTH CAROLINA 29730

751-20-7

GSD