



GaAs MMIC SP4T NON-REFLECTIVE SWITCH, DC - 8 GHz

Typical Applications

The HMC344LC3 is ideal for:

- Broadband, Military, Radar & ECM
- Fiber Optics
- Switched Filter Banks
- Wireless below 8 GHz
- Test Instrumentation

Features

- Broadband Performance: DC - 8 GHz
- Integrated 2:4 TTL Decoder
- High Isolation: 40 dB@ 6 GHz
- Low Insertion Loss: 2 dB@ 6 GHz
- Non-Reflective Topology

Functional Diagram

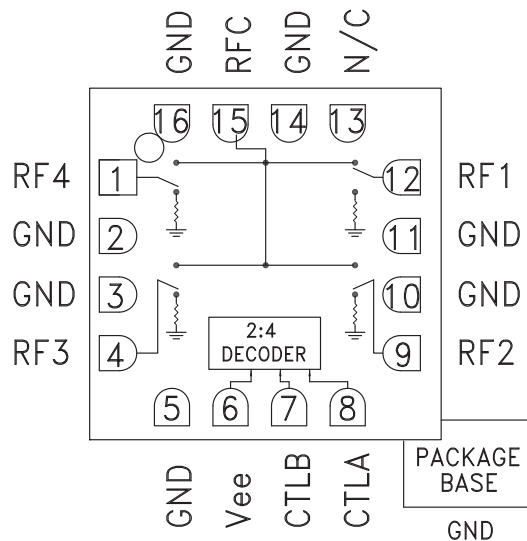

General Description

The HMC344LC3 is a broadband non-reflective GaAs MESFET SP4T switch in a ceramic 3x3 mm leadless surface mount package. Covering DC to 8 GHz, this switch offers high isolation and low insertion loss. The HMC344LC3 includes an integrated binary decoder circuit which reduces the required logic control lines to two. The switch operates using a negative control voltage of 0/-5V, and requires a fixed bias of -5V. Simple external level shifting circuitry allows this switch to be controlled with most TTL/CMOS positive logic families.

Electrical Specifications, $T_A = +25^\circ C$, With 0/-5V Control, 50 Ohm System

Parameter	Frequency	Min.	Typ.	Max.	Units
Insertion Loss	DC - 2.0 GHz		1.6	2.0	dB
	DC - 6.0 GHz		2.0	2.8	dB
	DC - 8.0 GHz		2.5	3.0	dB
Isolation	DC - 2.0 GHz	43	50		dB
	DC - 4.0 GHz	35	45		dB
	DC - 6.0 GHz	32	45		dB
	DC - 8.0 GHz	30	40		dB
Return Loss	DC - 2.0 GHz	15	17		dB
	DC - 4.0 GHz	12	16		dB
	DC - 6.0 GHz	12	16		dB
	DC - 8.0 GHz	12	17		dB
Return Loss	"Off State"	DC - 8.0 GHz	12	15	dB
Input Power for 0.1 dB Compression	0.5 - 8.0 GHz	22	26		dBm
Input Third Order Intercept (Two-Tone Input Power = +7 dBm Each Tone)	0.5 - 8.0 GHz		43		dBm
Switching Characteristics tRISE, tFALL (10/90% RF) tON, tOFF (50% CTL to 10/90% RF)	DC - 8.0 GHz		20		ns
			70		ns

For price, delivery, and to place orders, please contact Hittite Microwave Corporation:
 20 Alpha Road, Chelmsford, MA 01824 Phone: 978-250-3343 Fax: 978-250-3373
 Order On-line at www.hittite.com



GaAs MMIC SP4T NON-REFLECTIVE SWITCH, DC - 8 GHz

Insertion Loss vs. Temperature

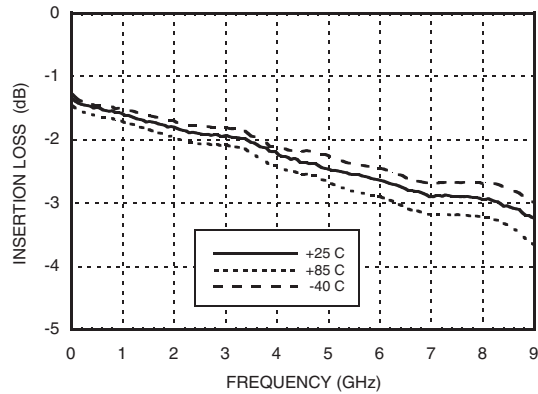

Isolation

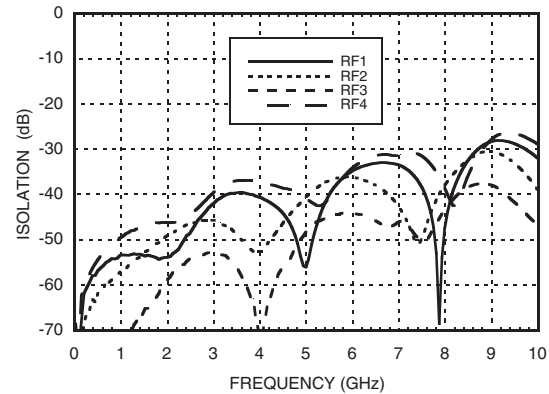

Return Loss

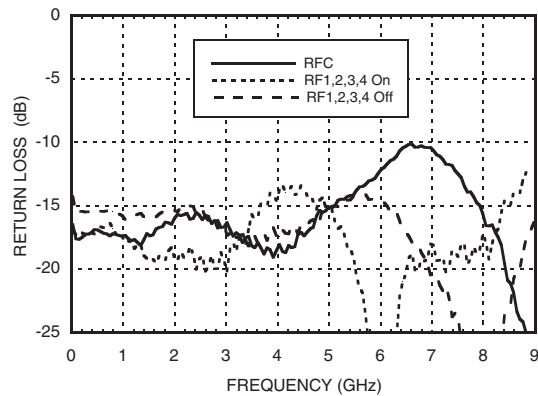

0.1 and 1 dB Input Compression Point

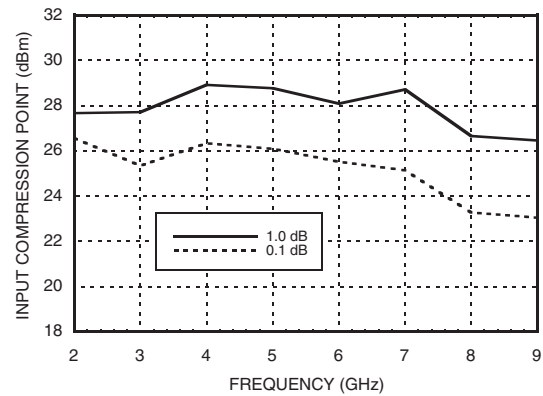

Input Third Order Intercept Point

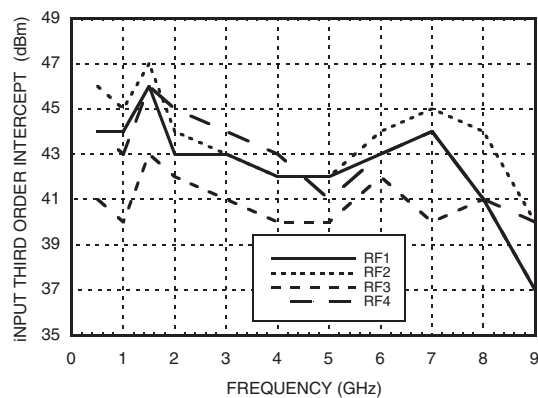

Bias Voltage & Current

Vee Range = -5.0 Vdc ± 10%		
Vee (Vdc)	I _{ee} (Typ.) (mA)	I _{ee} (Max.) (mA)
-5.0	3.0	6.0

Control Voltages

State	Bias Condition
Low	-3V to 0 Vdc @ 60 uA Typical
High	-5 to -4.2 Vdc @ 5 uA Typical

* Isolation is recorded above insertion loss & measured at output of switch.

For price, delivery, and to place orders, please contact Hittite Microwave Corporation:
20 Alpha Road, Chelmsford, MA 01824 Phone: 978-250-3343 Fax: 978-250-3373
Order On-line at www.hittite.com

GaAs MMIC SP4T NON-REFLECTIVE SWITCH, DC - 8 GHz

Absolute Maximum Ratings

Bias Voltage Range (Vee)	-7.0 Vdc
Control Voltage Range (A & B)	Vee -0.5V to +1.0 Vdc
Channel Temperature	150 °C
Thermal Resistance (Insertion Loss Path)	100 °C/W
Thermal Resistance (Terminated Path)	180 °C/W
Storage Temperature	-65 to +150 °C
Operating Temperature	-40 to +85 °C
Maximum Input Power (Low Loss State)	+28 dBm
ESD Sensitivity (HBM)	Class 1A

Truth Table

Control Input		Signal Path State
A	B	RFC to:
High	High	RF1
Low	High	RF2
High	Low	RF3
Low	Low	RF4



**ELECTROSTATIC SENSITIVE DEVICE
OBSERVE HANDLING PRECAUTIONS**

Outline Drawing

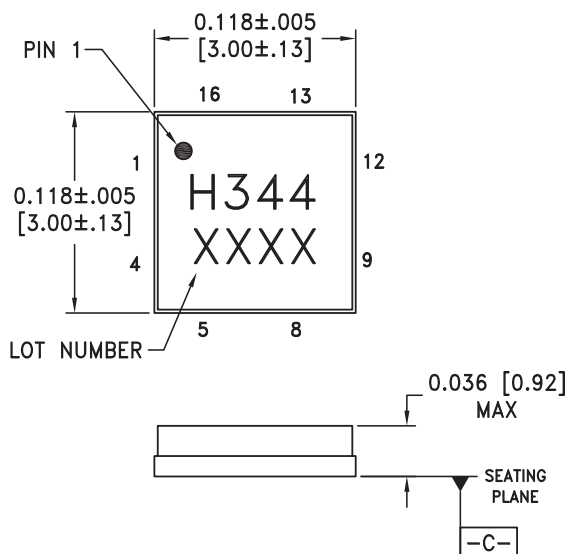

BOTTOM VIEW

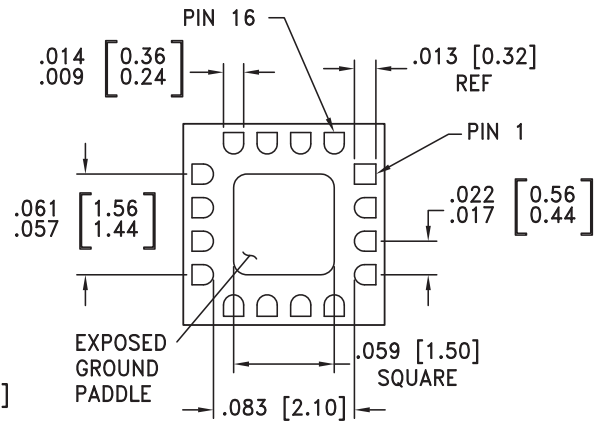

NOTES:

1. PACKAGE BODY MATERIAL: ALUMINA
2. LEAD AND GROUND PADDLE PLATING: 30-80 MICROINCHES GOLD OVER 50 MICROINCHES MINIMUM NICKEL.
3. DIMENSIONS ARE IN INCHES [MILLIMETERS].
4. LEAD SPACING TOLERANCE IS NON-CUMULATIVE.
5. PACKAGE WARP SHALL NOT EXCEED 0.05mm DATUM -C-
6. ALL GROUND LEADS AND GROUND PADDLE MUST BE SOLDERED TO PCB RF GROUND.



GaAs MMIC SP4T NON-REFLECTIVE SWITCH, DC - 8 GHz

Pin Descriptions

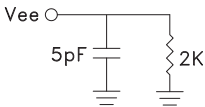
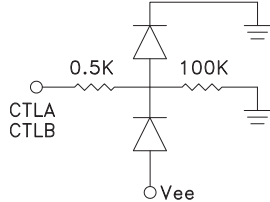
Pin Number	Function	Description	Interface Schematic
1, 4, 9, 12, 15	RF4, RF3, RF2, RF1, RFC	This pin is DC coupled and matched to 50 Ohm. Blocking capacitors are required if RF line potential is not equal to 0V.	
2, 3, 5, 10, 11, 14, 16	GND	Package bottom has exposed metal paddle that must also be connected to PCB RF ground.	
6	Vee	Supply Voltage -5V ± 10%	
7	CTLB	See truth table and control voltage table.	
8	CTLA	See truth table and control voltage table.	
13	N/C	This pin should be connected to PCB RF ground to maximize isolation.	



GaAs MMIC SP4T NON-REFLECTIVE SWITCH, DC - 8 GHz

TTL Interface Circuit

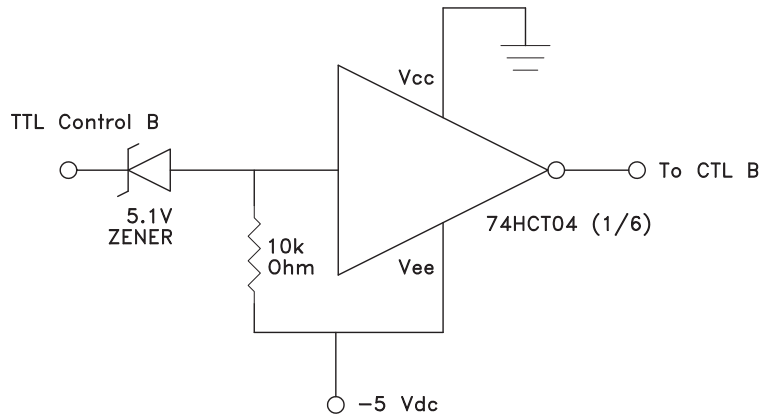
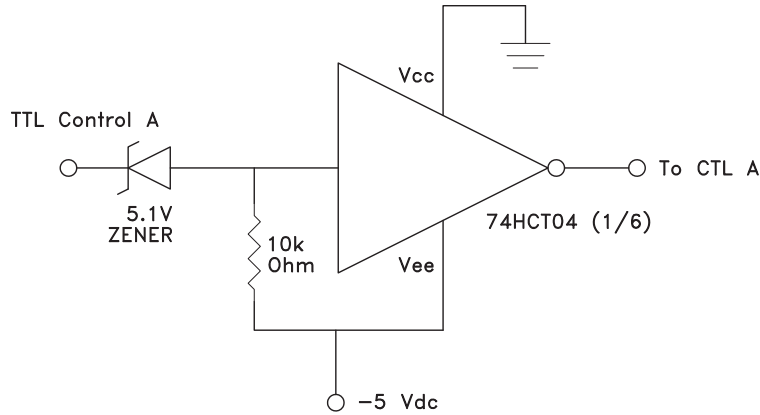

12

SWITCHES - MULTI-THROW - SMT

Evaluation PCB

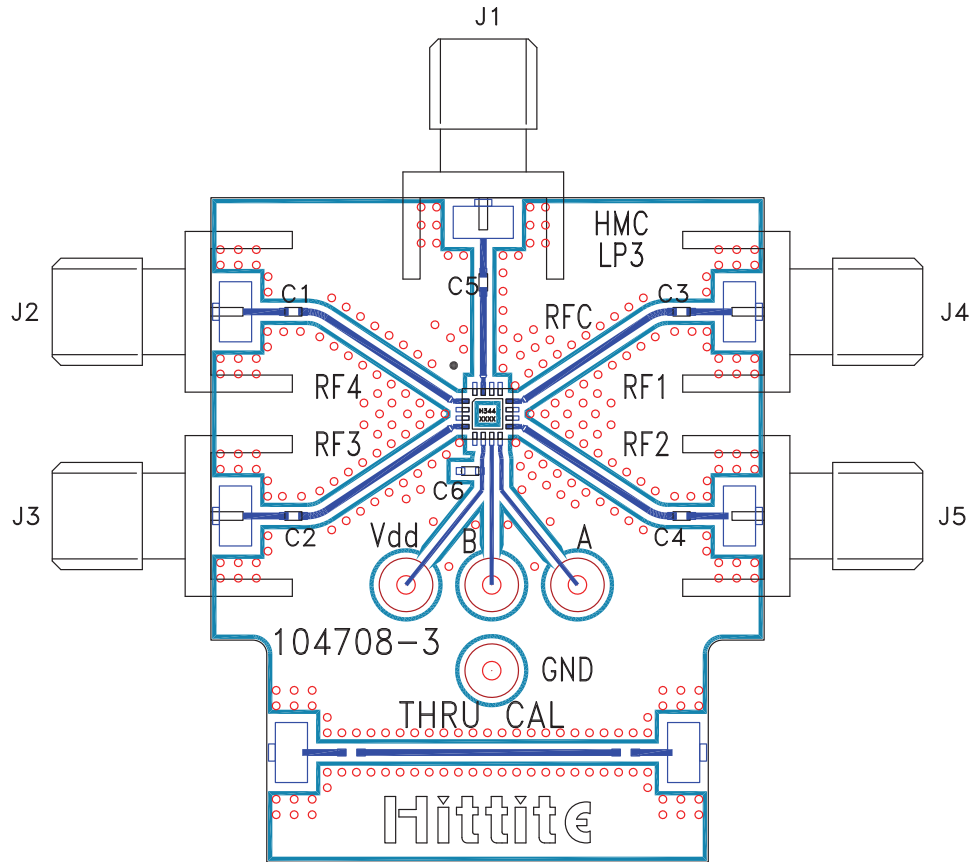

List of Materials for Evaluation PCB 105311 [1]

Item	Description
J1 - J7	PCB Mount SMA RF Connector
J8 - J11	DC Pin
C1 - C5	0Ω Resistor, 0402 Pkg.
C6	1000 pF Capacitor, 0402 Pkg.
U1	HMC344LC3
PCB [2]	104708 Evaluation PCB 1.29"x1.55"

[1] Reference this number when ordering complete evaluation PCB

[2] Circuit Board Material: Rogers 4350

The circuit board used in the final application should be generated with proper RF circuit design techniques. Signal lines at the RF port should have 50 ohm impedance and the package ground leads and backside ground slug should be connected directly to the ground plane similar to that shown above. The evaluation circuit board shown above is available from Hittite Microwave Corporation upon request.