

25 Mil Pitch, IEEE 1284 Termination Network Resistor, Capacitor, Diode



Product is pictured larger than actual size to show detail

Vishay has upgraded the standard IEEE 1284 Thin Film technology Network, incorporating diodes for protecting the inputs/outputs from electro-static discharge (ESD).

The sophisticated circuit is housed in a standard QSOP, 28-pin package.

Uses include ECP/EPP parallel port terminations for PC peripherals, notebooks, desktops, workstations and servers. This is a guaranteed stock part.

FEATURES

- Lead (Pb)-free available
- One sophisticated, integrated Thin Film technology solution
- Up-graded IEEE 1284 parallel port termination, pull-up with the addition of diodes for filtering on the parallel port
- Standard QSOP package (28 pins) - JEDEC mo-137AF
- 17 terminating lines
- Reduces total cost
- Increase board utilization
- Better performance over discretes



STANDARD ELECTRICAL SPECIFICATIONS	
Absolute Tolerance (R)	± 10 %
Absolute Tolerance (C)	± 20 %
Power Rating	Per Resistor 100 mW Per Package 1 Watt
Signal Clamp Voltage	(+) Clamp > 6 V (-) Clamp < - 6 V
Maximum Leakage Current at V _{CC} Max	1 µA at 25 °C
Operating Temperature	0 °C to + 70 °C
Storage Temperature	- 65 °C to + 150 °C

MECHANICAL SPECIFICATIONS	
R/C Element	Polysilicon/Thin Film
Substrate Material	Silicon
Body	Molded Epoxy
Terminals	Copper Alloy
Plating	Tin Lead solder
Lead Coplanarity	0.005 Inches
Marking Resistance to Solvents	MIL-STD-202, Method 15
Flammability	UL94 V-0

RC NETWORKS

SCHEMATIC

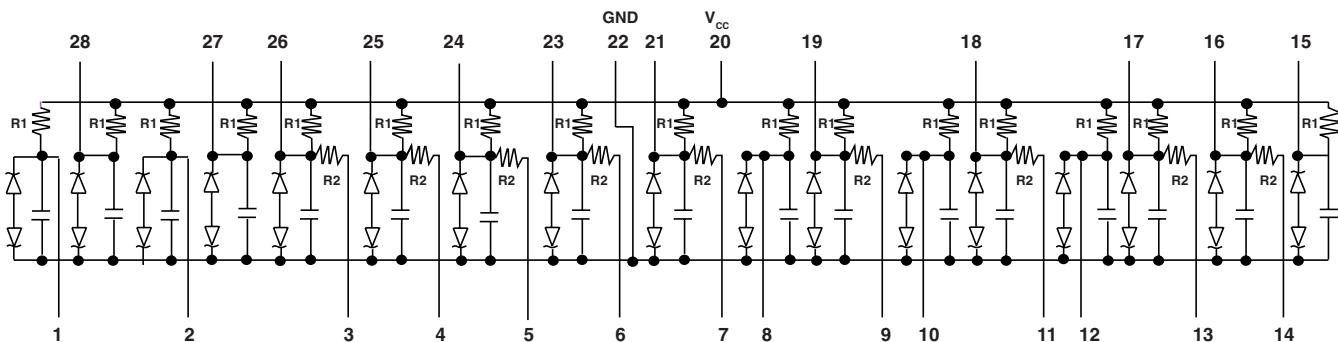

* Pb containing terminations are not RoHS compliant, exemptions may apply



ESD PROTECTION		
	MAX.	MIN.
Peak Discharge Voltage at any I/O, Human Body Model, Method 3015 (Note 1)	+ 8 kV	- 4 kV
In System Protection HBM (Note 2)	+ 15 kV	- 8 kV
In System Protection, IEC 1000-4-2, Level 2 (Note 2, 3)	+ 8 kV	- 4 kV
Channel Clamp Voltage at 8 kV ESD Pulses, HBM (Note 1, 2)	+ 30 V	- 30 V

- NOTE 1:** Human Body Model per MIL-STD-883, Method 3015
 $C_{Discharge} = 100 \text{ pF}$, $R_{Discharge} = 1.5 \text{ k}\Omega$ pin 20 at 5 V and pin 22 at ground
- NOTE 2:** Pin 22 grounded, pin 20 to VCC all other pins are open. ESD contact discharge between ground and Pins 1, 2, 8, 10, 12, 15, 16, 17, 18, 19, 21, 23 through 28, one at a time.
- NOTE 3:** Standard IEC 1000-4-2 with $C_{Discharge} = 150 \text{ pF}$, $R_{Discharge} = 330 \Omega$ pin 20 at 5 V and pin 22 at ground

DIMENSIONS AND IMPRINTING in inches and millimeters

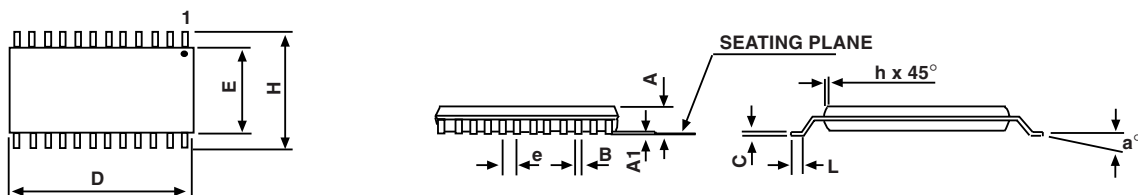

MODEL	A	A1	B	C	D	E	e	H	h	L	a°
Inches max.	0.068	0.008	0.012	0.010	0.394	0.157	0.025	0.244	0.016	0.038	8
Millimeters max.	1.727	0.203	0.305	0.254	10.008	3.988	0.635	6.198	0.406	0.889	

NOTE: Mold flash not included in body dimensions.
 JEDEC MO137 Package

AVAILABLE MODELS			
	R1 (Ohms)	R2 (Ohms)	C (pF)
VSSX1284A	4.7K	33	180
VSSX1284B	2.2K	33	220

GLOBAL PART NUMBER INFORMATION

Global Part Numbering: VSSX1284AT

V	S	S	X	1	2	8	4	A	T
---	---	---	---	---	---	---	---	---	---

SPECIFY MODEL

VSSX1284A
or
VSSX1284B

PACKAGING

R = Tape and Reel
T = Tubes

RC NETWORKS



Notice

Specifications of the products displayed herein are subject to change without notice. Vishay Intertechnology, Inc., or anyone on its behalf, assumes no responsibility or liability for any errors or inaccuracies.

Information contained herein is intended to provide a product description only. No license, express or implied, by estoppel or otherwise, to any intellectual property rights is granted by this document. Except as provided in Vishay's terms and conditions of sale for such products, Vishay assumes no liability whatsoever, and disclaims any express or implied warranty, relating to sale and/or use of Vishay products including liability or warranties relating to fitness for a particular purpose, merchantability, or infringement of any patent, copyright, or other intellectual property right.

The products shown herein are not designed for use in medical, life-saving, or life-sustaining applications. Customers using or selling these products for use in such applications do so at their own risk and agree to fully indemnify Vishay for any damages resulting from such improper use or sale.