HA13143

Four-Channel BTL Driver for CD Players

HITACHI

ADE-207-330 (Z)

1st Edition
Dec. 2000

Description

HA13143 is a four-channel BTL driver IC for driving CD player actuators (focus and tracking) and motors (carriage and spindle). It is ideal for small-profile players, since it requires few external parts and adopts a compact, surface-mounting package (MP-26 DT).

Functions

- 4-channel BTL driver
- 5 V power-supply circuit
- Standby circuit
- Built-in protection circuits (surge current, TSD)

Features

- Four channels for driving the actuators and motors in a CD player
- High driving current
- Built-in protection against surge currents from other circuits or from short circuits
- Built-in thermal shutdown protection circuit with hysteresis
- Built-in 5 V power supply (uses external pnp transistor)
- Compact MP-26 DT surface-mounting package enabling use in small-profile players

HA13143

Block Diagram

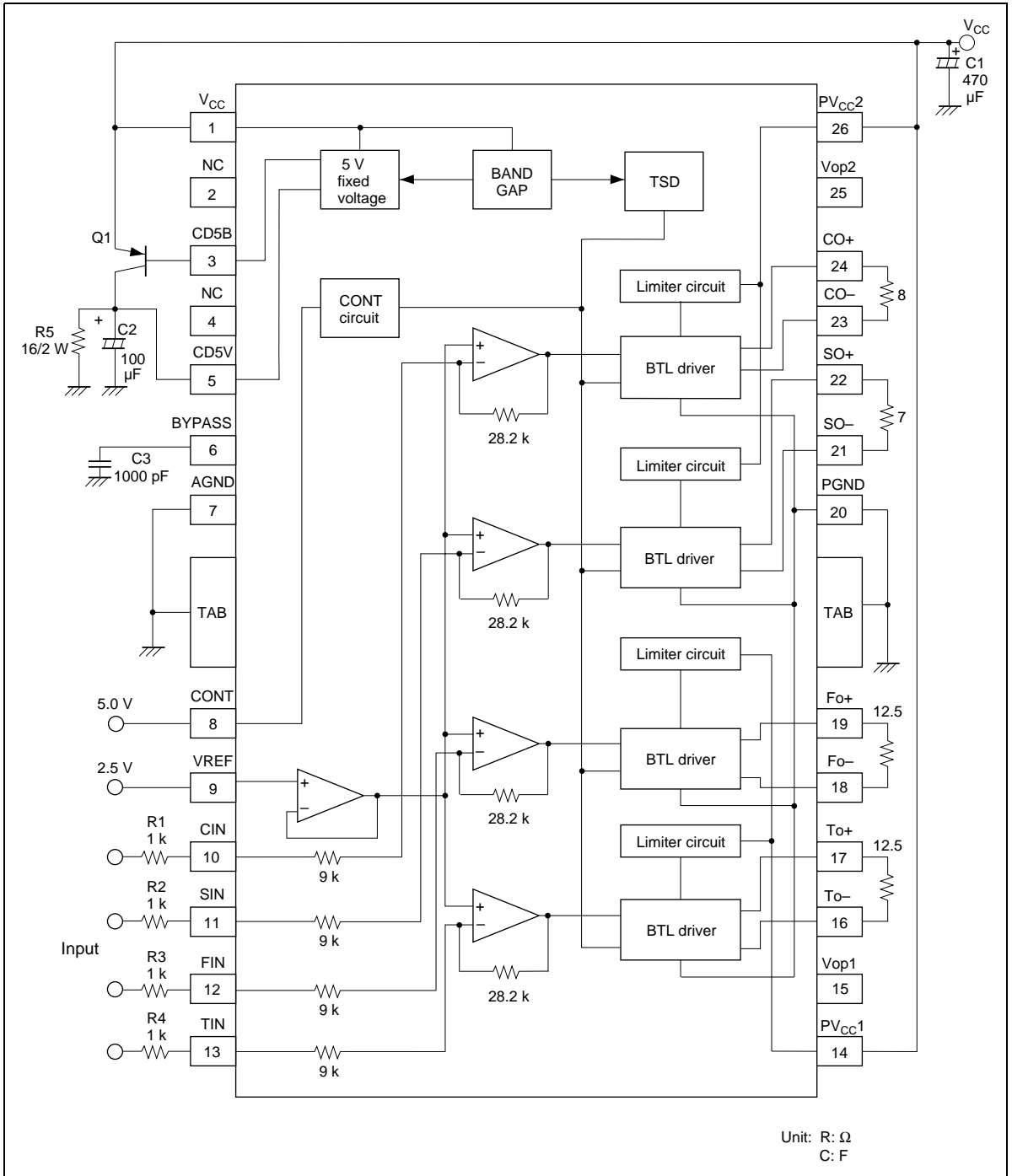

Absolute Maximum Ratings ($T_a = 25^\circ\text{C}$)

Item	Symbol	Rating	Unit	Remarks
Supply voltage	V_{cc}	18	V	
Output current	I_o -Peak	See Note 1	A	1
Power dissipation	P_T	2.5	W	2
Operating temperature	T_{opr}	-30 to +85	$^\circ\text{C}$	
Storage temperature	T_{stg}	-55 to +125	$^\circ\text{C}$	
Junction temperature	T_j	150	$^\circ\text{C}$	

Notes: 1. Output current from each channel is as shown in table below.

	Focus	Tracking	Carriage	Spindle	Unit
Max. output current	1200	1200	1200	1400	mA

2. In normal play mode.
3. Usable operating voltage range $V_{opr} = 7$ to 10 V.
4. The derating curve is as shown in the graph below ($\theta_{jc} = 8.0^\circ\text{C max.}$).

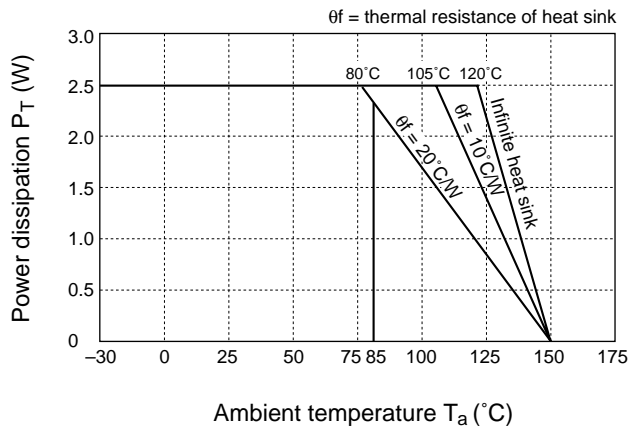

HA13143

Electrical Characteristics (Ta = 25°C, V_{cc} = 8.0 V)

Item	Symbol	Min	Typ	Max	Unit	Test Conditions	Applicable Pins
Output voltage with stable 5 V power supply	Vs	4.65	5.00	5.35	V	I _L = 300 mA	5
Ripple rejection	SVR vs	40	—	—	dB		5
Output leakage current	Io L5B	—	—	1.0	μA	V _{cc} = 0 V	3
Focus driver							
Output voltage	Vfo	3.75	3.95	4.15	V	R _L = 12.5 Ω	19, 20
Output offset voltage	VooF fo	-110	0	+110	mV	R _L = 12.5 Ω	19, 20
Gain	Gv fo	14	15	16	dB	R _L = 12.5 Ω, fin = 1 kHz	19, 20
Max. output amplitude	Vo fo	5.2	—	—	V	R _L = 12.5 Ω	19, 20
Ripple rejection	SVR fo	30	—	—	dB		19, 20
Cutoff frequency	Fc fo	50	100	200	kHz		19, 20
Tracking driver							
Output voltage	Vtr	3.75	3.95	4.15	V	R _L = 12.5 Ω	16, 17
Output offset voltage	VooFtr	-110	0	+110	mV	R _L = 12.5 Ω	16, 17
Gain	Gv tr	14	15	16	dB	R _L = 12.5 Ω, fin = 1 kHz	16, 17
Max. output amplitude	Vo tr	5.2	—	—	V	R _L = 12.5 Ω	16, 17
Ripple rejection	SVRtr	30	—	—	dB		16, 17
Cutoff frequency	fctr	50	100	200	kHz		16, 17
Spindle driver							
Output voltage	Vsp	3.80	4.00	4.20	V	R _L = 7.0 Ω	21, 22
Output offset voltage	VooFsp	-110	0	+110	mV	R _L = 7.0 Ω	21, 22
Gain	Gvsp	14	15	16	dB	R _L = 7.0 Ω, fin = 1 kHz	21, 22
Max. output amplitude	Vo sp	4.2	—	—	V	R _L = 7.0 Ω	21, 22
Ripple rejection	SVR sp	30	—	—	dB		21, 22
Cutoff frequency	fcsp	50	100	200	kHz		21, 22
Carriage driver							
Output voltage	Vcr	3.80	4.00	4.20	V	R _L = 8.0 Ω	23, 24
Output offset voltage	VooF cr	-110	0	+110	mV	R _L = 8.0 Ω	23, 24
Gain	Gvcr	14	15	16	dB	R _L = 8.0 Ω, fin = 1 kHz	23, 24
Max. output amplitude	Vocr	4.2	—	—	V	R _L = 8.0 Ω	23, 24
Ripple rejection	SVR cr	30	—	—	dB		23, 24
Cutoff frequency	Fccr	50	100	200	kHz		23, 24

Electrical Characteristics (Ta = 25°C, V_{CC} = 8.0 V) (cont)

Item	Symbol	Min	Typ	Max	Unit	Test Conditions	Applicable Pins
Channel crosstalk	CT	50	—	—	dB	fin = 1 kHz, 4 ch	16, 17, 18, 19, 21, 22, 23, 24
Operating voltage (1)	Vop1	3.75	3.95	4.15	V	Actuators	16
Operating voltage (2)	Vop2	3.80	4.00	4.20	V	Motors	25
Protection circuits							
Limiter operating current Focus	I _{LMT} fo	—	860	—	mA		18, 19
Limiter operating current Tracking	I _{LMT} tr	—	860	—	mA		16, 17
Limiter operating current Spindle	I _{LMT} sp	—	1100	—	mA		21, 22
Limiter operating current Carriage	I _{LMT} cr	—	930	—	mA		23, 24
TSD operating temperature	Ttsd	—	165	—	°C		
TSD hysteresis temperature	Thys	—	30	—	°C		
CONT circuit High-level input voltage	V _{IH} cut	—	—	3.0	V		8
0Low-level input voltage	V _{IL} cut	2.0	—	—	V		8
High-level input current	I _{IH} cut	0.3	1.0	5.0	μA	CONT = 3.0 V	8
Low-level input current	I _{IL} cut	—	—	0.1	μA	CONT = 2.0 V	8
Circuit current when no signal (standby)	Istby 1	4.0	6.0	10.0	mA	CONT = 2.0 V BYPASS = OPEN	1, 14, 26
Circuit current when no signal (standby)	Istby 2	3.0	5.0	9.0	mA	CONT = 3.0 V BYPASS = "L"	1, 14, 26
Circuit current when no signal	Icc 1	10	20	30	mA	CONT = 3.0 V BYPASS = OPEN	1, 14, 26
Bypass voltage	Vbps	1.3	1.45	1.6	V		6
Driving performance Focus	Io fo	500	860	—	mA		18, 19
Driving performance Tracking	Io tr	500	860	—	mA		16, 17
Driving performance Spindle	Io sp	750	1100	—	mA		21, 22
Driving performance Carriage	Io cr	650	930	—	mA		23, 24

HA13143

Package Dimensions

Unit: mm

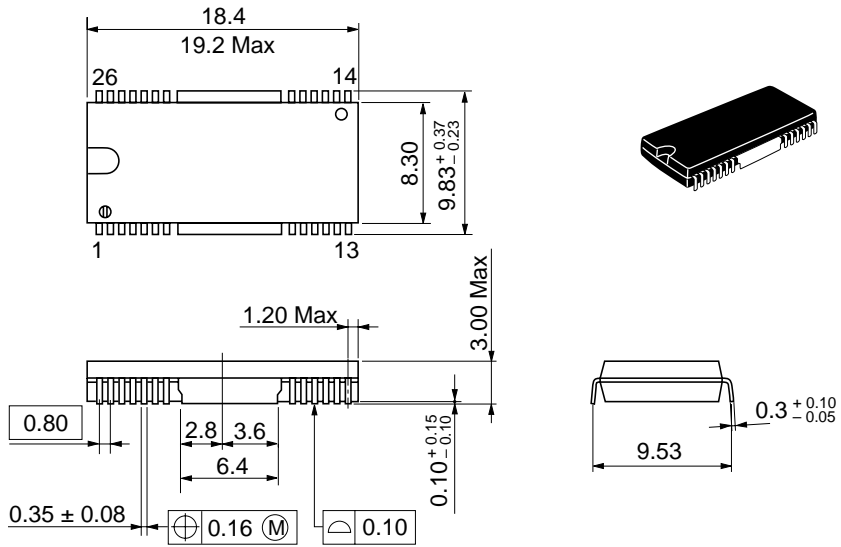

Hitachi Code	MP-26DT
JEDEC	—
EIAJ	—
Mass (reference value)	0.98 g

Disclaimer

1. Hitachi neither warrants nor grants licenses of any rights of Hitachi's or any third party's patent, copyright, trademark, or other intellectual property rights for information contained in this document. Hitachi bears no responsibility for problems that may arise with third party's rights, including intellectual property rights, in connection with use of the information contained in this document.
2. Products and product specifications may be subject to change without notice. Confirm that you have received the latest product standards or specifications before final design, purchase or use.
3. Hitachi makes every attempt to ensure that its products are of high quality and reliability. However, contact Hitachi's sales office before using the product in an application that demands especially high quality and reliability or where its failure or malfunction may directly threaten human life or cause risk of bodily injury, such as aerospace, aeronautics, nuclear power, combustion control, transportation, traffic, safety equipment or medical equipment for life support.
4. Design your application so that the product is used within the ranges guaranteed by Hitachi particularly for maximum rating, operating supply voltage range, heat radiation characteristics, installation conditions and other characteristics. Hitachi bears no responsibility for failure or damage when used beyond the guaranteed ranges. Even within the guaranteed ranges, consider normally foreseeable failure rates or failure modes in semiconductor devices and employ systemic measures such as fail-safes, so that the equipment incorporating Hitachi product does not cause bodily injury, fire or other consequential damage due to operation of the Hitachi product.
5. This product is not designed to be radiation resistant.
6. No one is permitted to reproduce or duplicate, in any form, the whole or part of this document without written approval from Hitachi.
7. Contact Hitachi's sales office for any questions regarding this document or Hitachi semiconductor products.

Sales Offices

HITACHI

Hitachi, Ltd.

Semiconductor & Integrated Circuits.

Nippon Bldg., 2-6-2, Ohte-machi, Chiyoda-ku, Tokyo 100-0004, Japan
Tel: Tokyo (03) 3270-2111 Fax: (03) 3270-5109

URL NorthAmerica : <http://semiconductor.hitachi.com/>
 Europe : <http://www.hitachi-eu.com/hel/ecg>
 Asia : <http://sicapac.hitachi-asia.com>
 Japan : <http://www.hitachi.co.jp/Sicd/indx.htm>

For further information write to:

Hitachi Semiconductor
(America) Inc.
179 East Tasman Drive,
San Jose, CA 95134
Tel: <1>(408) 433-1990
Fax: <1>(408) 433-0223

Hitachi Europe GmbH
Electronic Components Group
Dornacher Straße 3
D-85622 Feldkirchen, Munich
Germany
Tel: <49> (89) 9 9180-0
Fax: <49> (89) 9 29 30 00

Hitachi Europe Ltd.
Electronic Components Group.
Whitebrook Park
Lower Cookham Road
Maidenhead
Berkshire SL6 8YA, United Kingdom
Tel: <44> (1628) 585000
Fax: <44> (1628) 585160

Hitachi Asia Ltd.
Hitachi Tower
16 Collyer Quay #20-00,
Singapore 049318
Tel : <65>-538-6533/538-8577
Fax : <65>-538-6933/538-3877
URL : <http://www.hitachi.com.sg>

Hitachi Asia Ltd.
(Taipei Branch Office)
4/F, No. 167, Tun Hwa North Road,
Hung-Kuo Building,
Taipei (105), Taiwan
Tel : <886>-(2)-2718-3666
Fax : <886>-(2)-2718-8180
Telex : 23222 HAS-TP
URL : <http://www.hitachi.com.tw>

Hitachi Asia (Hong Kong) Ltd.
Group III (Electronic Components)
7/F., North Tower,
World Finance Centre,
Harbour City, Canton Road
Tsim Sha Tsui, Kowloon,
Hong Kong
Tel : <852>-(2)-735-9218
Fax : <852>-(2)-730-0281
URL : <http://www.hitachi.com.hk>

Copyright © Hitachi, Ltd., 2000. All rights reserved. Printed in Japan.
Colophon 2.0