



SANYO Semiconductors

# DATA SHEET

An ON Semiconductor Company

## LC01707PLF — CMOS LSI FM multiple tuner IC

### Overview

LC01707PLF is a vehicle-mounted FM multiple tuner IC with FM-FE, IF, IF-Filter, PLL, FM-DEMO and LPF incorporated. An FM multiple tuner can be developed with this one chip. It makes up a small-sized FM multiple tuners which can be mounted on PND.

### Functions

- It is the FM tuner IC exclusively for the FM multiple.
- Image reduction complex BPF is incorporated
- Narrow Band IF AGC is incorporated
- DLL detection method is adopted for the FM detection circuit, and it is not necessary to adjust.
- LPF for the carrier removal is incorporated.
- It is a BUS control tuner IC which can be controlled by controlled by I<sup>2</sup>C BUS.
- LNA is incorporated
- Wide / Narrow Band RF AGC is incorporated
- Image rejection is adopted
- IC requires fewer external components.

### Specifications

Maximum Ratings at Ta = 25°C

| Parameter                    | Symbol              | Conditions   | Ratings    | Unit |
|------------------------------|---------------------|--------------|------------|------|
| Supply voltage               | V <sub>DD</sub> max |              | 4.3        | V    |
| Maximum input voltage        | V <sub>DD</sub> H   |              | 4.3        | V    |
| Maximum output voltage       | V <sub>DD</sub> L   |              | 4.3        | V    |
| Power dissipation            | P <sub>d</sub> max  | Ta = 85°C *1 | 700        | mW   |
| Operating ambient            | T <sub>opr</sub>    |              | -40 to 85  | °C   |
| Storage temperature          | T <sub>stg</sub>    |              | -55 to 150 | °C   |
| Maximum junction temperature | T <sub>j</sub> max  |              | 150        | °C   |

\*1: Board size: 80mm × 70mm × 1.6mm Glass epoxy double-sided board

■ Any and all SANYO Semiconductor Co.,Ltd. products described or contained herein are, with regard to "standard application", intended for the use as general electronics equipment. The products mentioned herein shall not be intended for use for any "special application" (medical equipment whose purpose is to sustain life, aerospace instrument, nuclear control device, burning appliances, transportation machine, traffic signal system, safety equipment etc.) that shall require extremely high level of reliability and can directly threaten human lives in case of failure or malfunction of the product or may cause harm to human bodies, nor shall they grant any guarantee thereof. If you should intend to use our products for new introduction or other application different from current conditions on the usage of automotive device, communication device, office equipment, industrial equipment etc. , please consult with us about usage condition (temperature, operation time etc.) prior to the intended use. If there is no consultation or inquiry before the intended use, our customer shall be solely responsible for the use.

■ Specifications of any and all SANYO Semiconductor Co.,Ltd. products described or contained herein stipulate the performance, characteristics, and functions of the described products in the independent state, and are not guarantees of the performance, characteristics, and functions of the described products as mounted in the customer's products or equipment. To verify symptoms and states that cannot be evaluated in an independent device, the customer should always evaluate and test devices mounted in the customer's products or equipment.

SANYO Semiconductor Co., Ltd.

<http://semicon.sanyo.com/en/network>

# LC01707PLF

## Recommended Operating Conditions at Ta = 25°C

| Parameter                      | Symbol          | Conditions | Ratings    | Unit |
|--------------------------------|-----------------|------------|------------|------|
| Supply voltage range           | V <sub>DD</sub> |            | 3.0 to 3.6 | V    |
| Recommended supply temperature | V <sub>DD</sub> |            | 3.3        | V    |

## Electrical Characteristics at Ta = 25°C, V<sub>DD</sub> = 3.3V,

fc = 83MHz, VIN=60dBμVEMF, fm=1kHz, Audio filter: HPF=100Hz, LPF=15kHz

Resister setting: IF AGC (02h) =6(110), RF AGC (00h) =0(0000)

DLL demodulator loop gain setting (09h) =1(01), Mono multi center setting (09h) =7(0111)

| Parameter                         | Symbol | Conditions                                    | Ratings |     |     | Unit   |
|-----------------------------------|--------|---|---------|-----|-----|--------|
|                                   |        |   | min     | typ | max |        |
| Practical sensitivity 1 (S/N30dB) | SN30   | 22.5kHz dev, fm=1kHz, S/N=30dB input level    |         | 12  | 20  | dBμEMF |
| Practical sensitivity 2 (S/N10dB) | SN10   | 7.5kHz dev, fm=76kHz, S/N=10dB input level *1 |         | 27  |     | dBμEMF |
| S/N1                              | SN1    | 22.5kHz dev, fm=1kHz                          | 34      | 44  |     | dB     |
| S/N2                              | SN2    | 7.5kHz dev, fm=76kHz *1                       |         | 21  |     | dB     |
| Total harmonic distortion rate 1  | THD_1  | 22.5kHz dev, fm=1kHz                          |         | 0.5 |     | %      |
| Total harmonic distortion rate 2  | THD_2  | 75.0kHz dev, fm=1kHz                          |         | 0.5 |     | %      |
| AM suppression ratio              | AMR    | AM 30% mod                                    | 34      | 44  |     | dB     |
| Image rejection ratio             | IMR    | 22.5kHz dev, fm=1kHz                          |         | 32  |     | dB     |
| Audio output level 1              | AD01   | 7.5kHz dev, fm=1kHz *1                        | 26      | 39  | 70  | mVrms  |
| Audio output level 2              | AD02   | 7.5kHz dev, fm=76kHz *1                       | 15      | 23  | 41  | mVrms  |
| Consumption current               | IDD    | No signal input                               |         | 106 | 170 | mA     |

\*1: Audio filter: HPF=100Hz, LPF=OFF

## Package Dimensions

unit : mm (typ)

3408

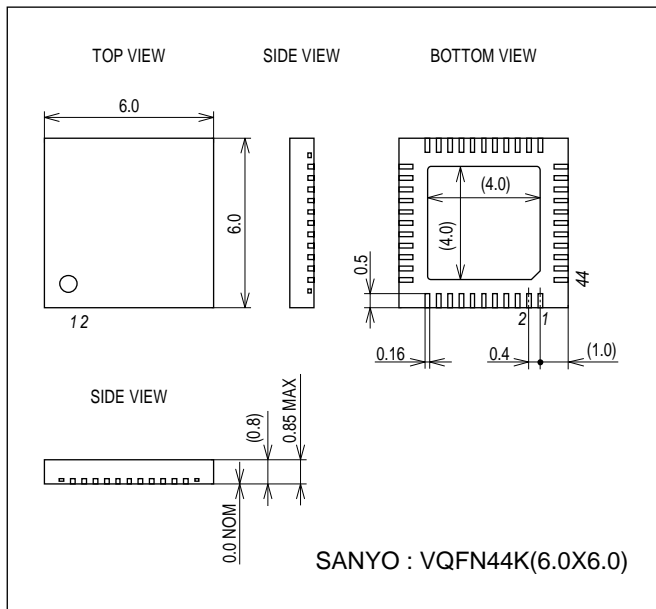



# LC01707PLF

## Pin Description

| Pin No. | Pin name        | I/O | Function  |
|---------|-----------------|-----|---|
| 1       | NAGC            | O   | Narrow band AGC detection capacitance connecting pin  |
| 2       | WAGC            | O   | Wide band AGC detection capacitance connecting pin    |
| 3       | V <sub>SS</sub> | P   | GND pin for IF  |
| 4       | NC              | -   |   |
| 5       | NC              | -   |   |
| 6       | V <sub>DD</sub> | P   | Supply pin for LNA                                    |
| 7       | LNA_A           | I   | LNA +input pin  |
| 8       | V <sub>SS</sub> | P   | GND pin for LNA                                       |
| 9       | LNA_N           | I   | LNA -input pin  |
| 10      | NC              | -   |   |
| 11      | NC              | -   |   |
| 12      | V <sub>SS</sub> | P   | GND pin for 1 <sup>st</sup> Mixer                     |
| 13      | CP              | O   | PLL charge pump capacitance connecting pin            |
| 14      | V <sub>DD</sub> | P   | Supply pin 1 <sup>st</sup> Mixer                      |
| 15      | V <sub>DD</sub> | P   | Supply pin for local oscillation                      |
| 16      | LO_1            | O   | Inductor connecting pin for local oscillation         |
| 17      | V <sub>SS</sub> | P   | GND pin for local oscillation                         |
| 18      | LO_2            | O   | Inductor connecting pin for local oscillation         |
| 19      | NC              | -   |   |
| 20      | NC              | -   |   |
| 21      | NC              | -   |   |
| 22      | NC              | -   |   |
| 23      | DEVER           | I   | Device address setting pin                            |
| 24      | V <sub>SS</sub> | P   | GND pin for PLL and logic                             |
| 25      | XTAL            | I   | Crystal resonator connecting pin (Clock input pin)    |
| 26      | SD              | O   | Station detector pin                                  |
| 27      | NC              | -   |   |
| 28      | NC              | -   |   |
| 29      | NC              | -   |   |
| 30      | INT             | O   | Test pin  |
| 31      | SCL             | I   | Serial data clock input                               |
| 32      | SDA             | I   | serial data input-output                              |
| 33      | V <sub>DD</sub> | P   | Supply pin for PLL and logic                          |
| 34      | SMETER          | O   | S-meter output  |
| 35      | V <sub>DD</sub> | P   | Supply pin for IF                                     |
| 36      | LPFO            | O   | Demodulation output (after band limitation)           |
| 37      | DEMOO           | O   | Demodulation output                                   |
| 38      | LPFI            | I   | Demodulation signal input pin                         |
| 39      | DEMO C          | O   | Capacitance connecting pin for demodulation detection |
| 40      | NC              | -   |   |
| 41      | NC              | -   |   |
| 42      | NC              | -   |   |
| 43      | NC              | -   |   |
| 44      | GND             | P   | GND pin   |

# LC01707PLF

## Pin Function

| Pin No. | Pin name | Function  | Equivalent circuit |
|---------|----------|---|--------------------|
| 1       | NAGC     | Narrow band AGC detection capacitor connection pin. |                    |
| 2       | WAGC     | Wide band AGC detection capacitor connection pin.   |                    |
| 3       | VSS      | GND pin for IF.                                     |                    |
| 4       | NC       | No connection.                                      |                    |
| 5       | NC       | No connection.                                      |                    |
| 6       | VDD      | Supply pin for LNA.                                 |                    |
| 7       | LNA_P    | Pin 7 is + input pin for LNA.                       |                    |
| 8       | VSS      | Pin 8 is GND pin for LNA.                           |                    |
| 9       | LNA_N    | Pin 9 is - input pin for LNA.                       |                    |
| 10      | NC       | No connection.                                      |                    |
| 11      | NC       | No connection.                                      |                    |
| 12      | VSS      | GND pin 1st mixer for the 1 <sup>st</sup> mixer.    |                    |
| 13      | CP       | PLL charge pump capacitor connection pin.           |                    |
| 14      | VDD      | Supply pin for the 1 <sup>st</sup> mixer.           |                    |
| 15      | VDD      | Supply pin for local oscillator.                    |                    |

Continued on next page.

# LC01707PLF

Continued from preceding page.

| Pin No.        | Pin name            | Function  | Equivalent circuit |
|----------------|---------------------|---|--------------------|
| 16<br>17<br>18 | LO_1<br>VSS<br>LO_2 | Pin 16 is inductor connection pin for local oscillator.<br>Pin 17 is GND pin for local oscillator.<br>Pin 18 is inductor connection pin for local oscillator. |                    |
| 19             | NC                  | No connection.  |                    |
| 20             | NC                  | No connection.  |                    |
| 21             | NC                  | No connection.  |                    |
| 22             | NC                  | No connection.  |                    |
| 23             | DEVAR               | Device address setting pin.   |                    |
| 24             | VSS                 | PLL_logic GND pin.  |                    |
| 25             | XTAL                | Crystal oscillator connection pin (clock input pin).  |                    |
| 26<br>30       | SD<br>INT           | Station detector pin.<br>Test monitor pin.  |                    |
| 27             | NC                  | No connection.  |                    |
| 28             | NC                  | No connection.  |                    |
| 29             | NC                  | No connection.  |                    |

Continued on next page.

# LC01707PLF

Continued from preceding page.

| Pin No. | Pin name | Function                                  | Equivalent circuit |
|---------|----------|---|--------------------|
| 31      | SCL      | Serial data clock input.                  |                    |
| 32      | SDA      | Serial data input/ output.                |                    |
| 33      | VDD      | PLL_logic supply voltage pin.             |                    |
| 34      | SMETER   | S-meter output.                           |                    |
| 35      | VDD      | IF supply voltage pin                     |                    |
| 36      | LPFO     | Demodulator output<br>(After band limit). |                    |
| 37      | DEMOO    | Demodulator output.                       |                    |
| 38      | LPFI     | Demodulator signal input pin.             |                    |

Continued on next page.

# LC01707PLF

Continued from preceding page.

| Pin No. | Pin name | Function  | Equivalent circuit |
|---------|----------|---|--------------------|
| 39      | DEMOC    | Capacitor connection pin for demodulator detection. |                    |
| 40      | NC       | No connection.                                      |                    |
| 41      | NC       | No connection.                                      |                    |
| 42      | NC       | No connection.                                      |                    |
| 43      | NC       | No connection.                                      |                    |
| 44      | GND      | GND pin.  |                    |

**Communication specification**

Communication specifications are indicated as below:

Serial Interface (I<sup>2</sup>C-bus);

Sending and receiving data through I<sup>2</sup>C-bus that consists of two bus lines of a serial data line (SDA) and a serial clock line (SCL). This bus enables 8-bit bi-directional serial data to transmit at the maximum speed of 400kbits (fast mode). This is not compatible with Hs mode.

Terms used in I<sup>2</sup>C

The following terms are used in I<sup>2</sup>C

| Terms       | Description   |
|-------------|---|
| Transmitter | Device to send data to the bus  |
| Receiver    | Device to receive from the bus  |
| Master      | Device to start data transmission, generate signal, and terminate data transmission |
| Slave       | Device of which address is designated master  |

[Start] and [Stop] conditions

[Start] condition is required at the start of data communication and [Stop] condition at the end of data communication. The condition in which the SDA line changes from [H] to [L] with SCL at [H] is called the [Start] condition. The condition in which the SDA line changes from [L] to [H] with SCL at [H] is called the [Stop] condition.

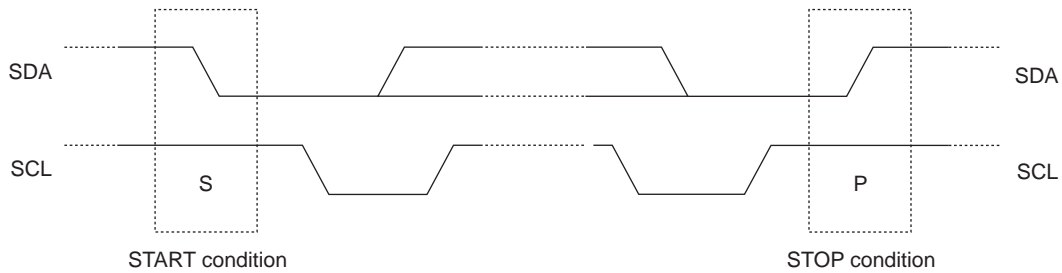

Data transmission

The length of each byte which is output to SDA line is always 8 bits. An acknowledge bit is needed after each byte. Data is transmitted sequentially from the most significant bit (MSB). During the data transfer, the slave address is transmitted after the [Start] condition (S). Data transfer is always ended by the [Stop] condition (P) generated by the master.

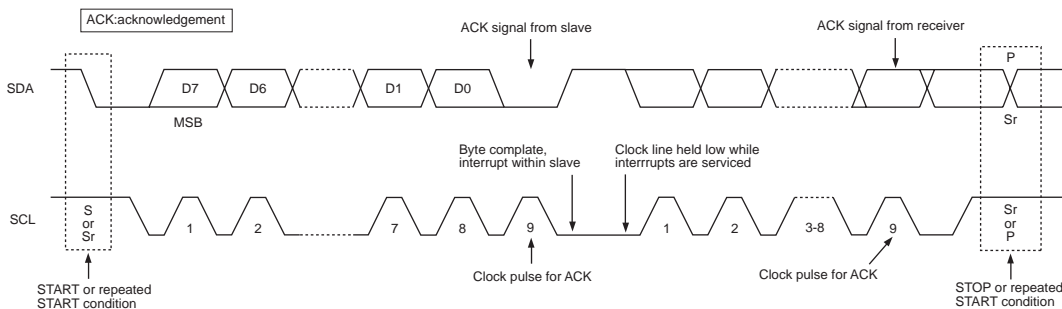

Acknowledge (Receive acknowledge)

When the master generates the acknowledge clock pulse, the transmitter opens the SDA line. (SDA line enters the [H] state.) When the acknowledge clock pulse is in the [H] state, the receiver sets the SDA line to [L] each time it receives one byte (eight bits) data. When the master works as a receiver, the master informs the slave of the end of data by omitting acknowledge at the end of data sent from the slave.

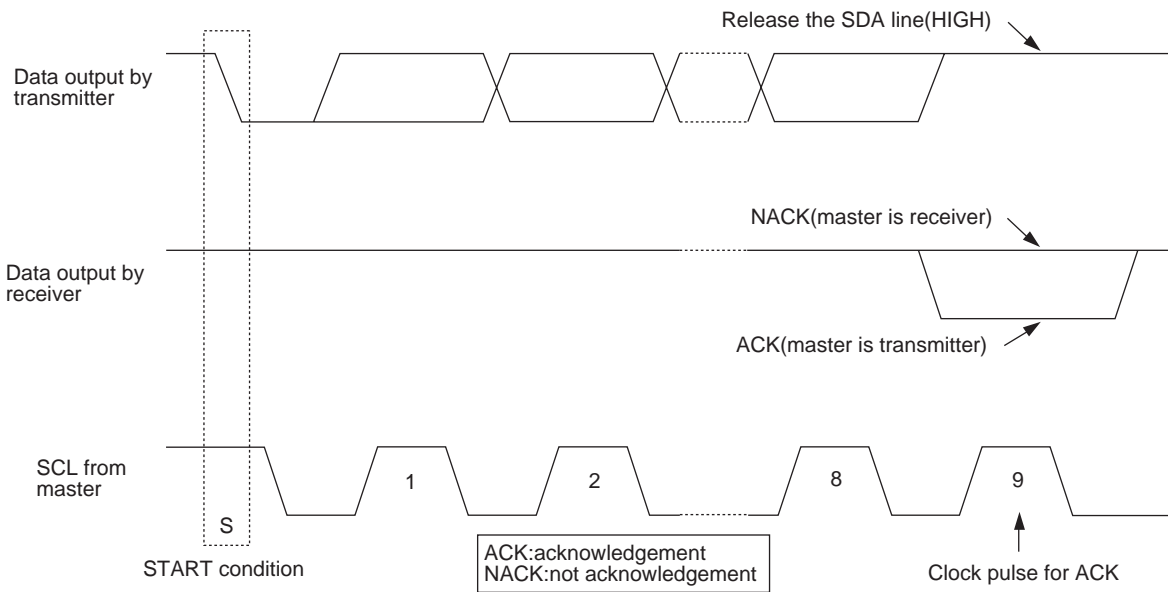

Software reset

If the communication is interrupted (microcomputer reset, etc.), it is possible to communicate normally by entering the below signals and resetting the CPU in software.

- \*These signal timings restore the communication after its interruption. The register setting is never reset.
- \*Software reset command is incompatible with I<sup>2</sup>C-bus format.

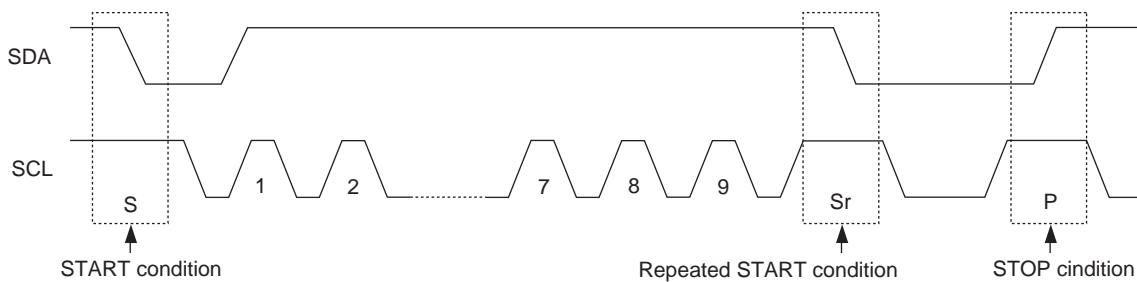

# LC01707PLF

## Electrical specification and timing for I/O stages

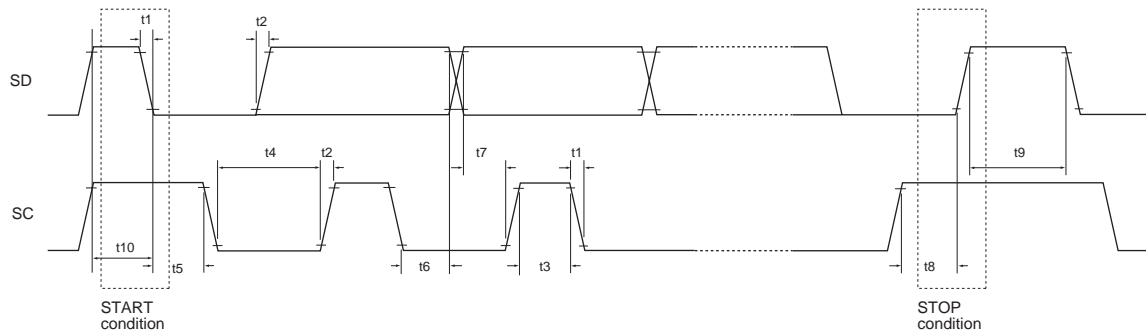

## Bus line characteristics

| Characteristic                                    | Symbol | FAST-MODE |     | unit | Example at<br>SCL = 100kHz |
|---|--------|-----------|-----|------|----------------------------|
|   |        | min       | max |      |                            |
| SCL clock frequency                               | fSCL   |           | 400 | kHz  | 100                        |
| Fall time of SDA and SCL                          | t1     | 20+0.1Cb  | 300 | ns   |                            |
| Rise time of SDA and SCL                          | t2     | 20+0.1Cb  | 300 | ns   |                            |
| SCL "H" time                                      | t3     | 0.6       |     | μs   | 3                          |
| SCL "L" time                                      | t4     | 1.3       |     | μs   | 7                          |
| [Start] condition holding time                    | t5     | 0.6       |     | μs   | 10                         |
| Data holding time for I <sup>2</sup> C bus device | t6     | 0.3       |     | μs   |                            |
| Data setup time                                   | t7     | 0.1       |     | μs   | 3                          |
| [Stop] condition setup time                       | t8     | 0.6       |     | μs   | 10                         |
| Bus free time between [Stop] and [Start]          | t9     | 1.3       |     | μs   | 20                         |
| [Start] condition setup time                      | t10    | 0.6       |     | μs   |                            |
| Bus line capacitive load                          | Cb     |           | 400 | pF   |                            |

## Serial interface voltage level

V<sub>DD</sub>: Communication bus voltage

| Characteristic                         | min                | max                | unit |
|--|--------------------|--------------------|------|
| High level input voltage               | 0.7V <sub>DD</sub> | V <sub>DD</sub>    | V    |
| Low level input voltage                | 0.0                | 0.3V <sub>DD</sub> | V    |
| High level output voltage (open drain) | V <sub>DD</sub> *2 |                    | V    |
| Low level output voltage (open drain)  | 0.0                | 0.2V <sub>DD</sub> | V    |

\*2: Output impedance of open drain becomes high at the high level output voltage.

Output voltage equals to V<sub>DD</sub> (voltage =V<sub>DD</sub>) since drain is pulled up to V<sub>DD</sub>.

# LC01707PLF

## Definition of each bit

### 1) Slave address

The slave address consists of seven-bit fixed address "1110000" or "1110001", which is unique to a chip, and the eighth-bit data direction bit(R/W). Sending (writing) is processed when the data direction bit is "0", and receiving (reading) is processed when it is "1". The fixed address is set to "1110001" at DEVAR=1 and it is set to "1110000" at DEVAR=0.

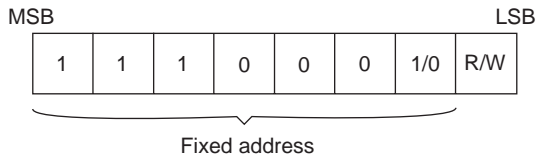

| R/W   | BIT |
|-------|-----|
| READ  | 1   |
| WRITE | 0   |

### 2) Register address

Since the total number of internal register is 34, 2-bit data set on the MSB side becomes invalid. 64 addresses are accepted 6 bits are used, but only 34 registers are used.

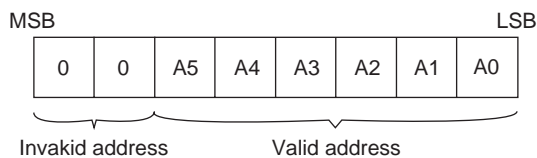

### 3) Register data

Each register data consists of eight bits.

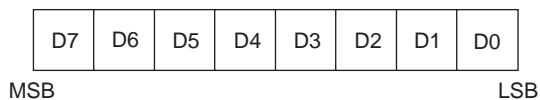

# LC01707PLF

## Command Format

### 1) Individual registers data writing

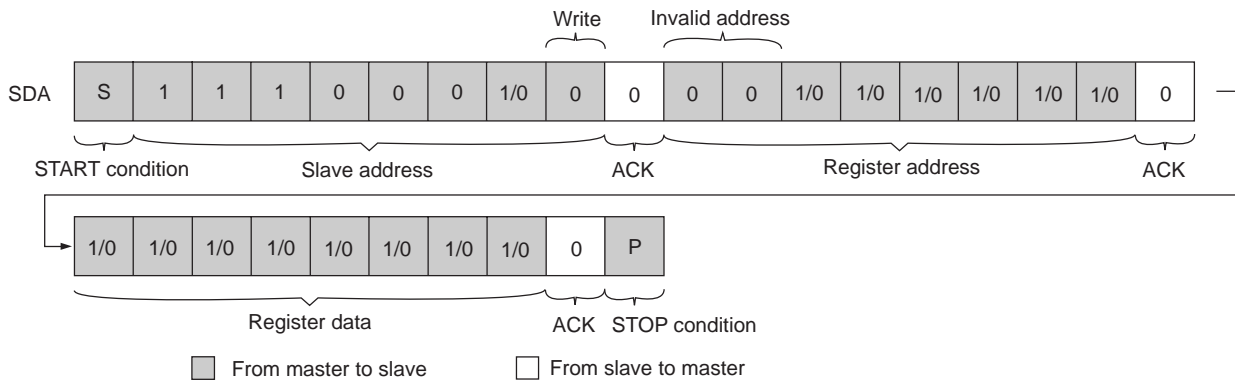

### 2) Individual registers data reading

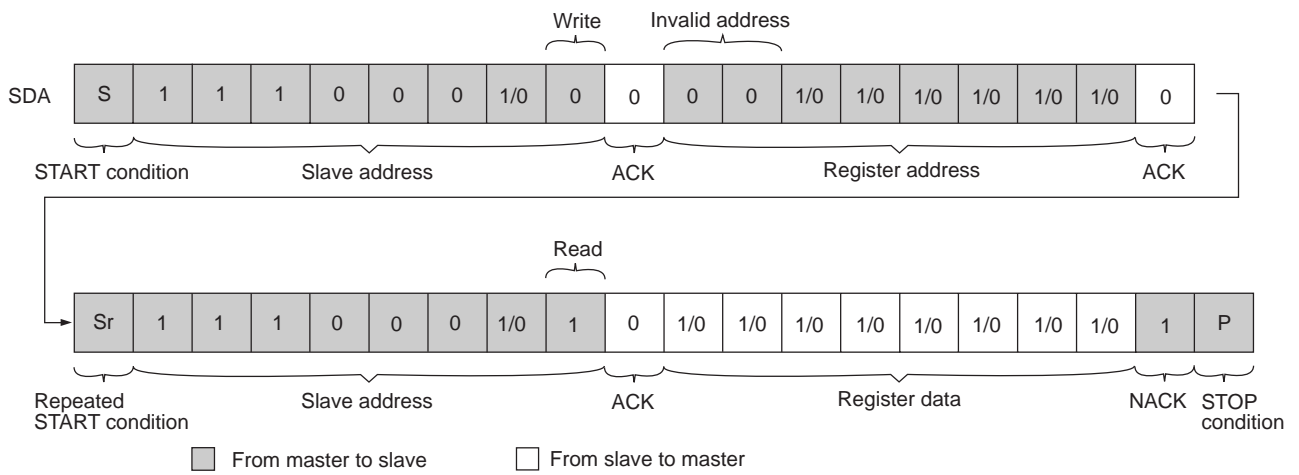

# LC01707PLF

## Register Map 1

\* HEX value is set by default.

■ : Unused BIT

| Register address | BIT        | Bit name   | Function   | Bit operation  | Read/Write | Binary value | Hex value |
|------------------|------------|------------|--|--|------------|--------------|-----------|
| 00h              | 7          |            |  |  |            | 0            | h'00      |
|                  | 6          | SD_SL[2]   | SD level detection setting   | 0:DRS0 1:DRS1 2:DRS2 3:DRS3 4:DRS4 5:DRS5 6:DRS6 7:DRS7  | R/W        | 0            |           |
|                  | 5          | SD_SL[1]   |  |  | R/W        | 0            |           |
|                  | 4          | SD_SL[0]   |  |  | R/W        | 0            |           |
|                  | 3          | DWAG[3]    | Wide band AGC level setting  | 0:15.6mVp-p 1:31.3mVp-p 2:46.9mVp-p 3:62.5mVp-p<br>4:78.1mVp-p 5:93.8mVp-p 6:109.4mVp-p 7:125.0mVp-p<br>8:140.6mVp-p 9:156.3mVp-p 10:171.9mVp-p 11:187.5mVp-p<br>12:203.1mVp-p 13:218.8mVp-p 14:234.4mVp-p 15:250mVp-p | R/W        | 0            |           |
|                  | 2          | DWAG[2]    |  |  | R/W        | 0            |           |
|                  | 1          | DWAG[1]    |  |  | R/W        | 0            |           |
| 0                | DWAG[0]    | R/W        |  |  | 0          |              |           |
| 01h              | 7          |            |  |  |            | 0            | h'00      |
|                  | 6          |            |  |  |            | 0            |           |
|                  | 5          |            |  |  |            | 0            |           |
|                  | 4          |            |  |  |            | 0            |           |
|                  | 3          |            |  |  |            | 0            |           |
|                  | 2          |            |  |  |            | 0            |           |
|                  | 1          | IMSD_SL[1] | Unused   |  |            |              |           |
| 0                | IMSD_SL[0] | 0          |  |  |            |              |           |
| 02h              | 7          | CLKIN      | XTAL current setting   | 1:Normal 0:Twice   | R/W        | 1            | h'99      |
|                  | 6          | DLOCKSEL   | LOCKDET output waveform selection  | 1:Number of comparing 6 0:Munber of comparing 3  | R/W        | 0            |           |
|                  | 5          | DFSEL[1]   | Phase comparison frequency selection   | 0:100kHz 1:50kHz 2:50kHz 3:25kHz   | R/W        | 0            |           |
|                  | 4          | DFSEL[0]   |  |  | R/W        | 1            |           |
|                  | 3          | ENPE       | Entire circuit enable  | 1:ON 0:OFF (Entire circuit OFF)  | R/W        | 1            |           |
|                  | 2          | DNGA[2]    | Narrow band AGC level setting  | 0:35mVp-p 1:111mVp-p 2:187mVp-p 3:263mVp-p<br>4:339mVp-p 5:415mVp-p 6:491mVp-p 7:567mVp-p<br>(When the setting value is ether 0 or 1 and MSK=4%, error is detected in BER.)  | R/W        | 0            |           |
|                  | 1          | DNGA[1]    |  |  | R/W        | 0            |           |
| 0                | DNGA[0]    | R/W        |  |  | 1          |              |           |
| 03h              | 7          | ENCPLEVEL  | Charge pump level comparison selection   | 1:ON 0:OFF   | R/W        | 1            | h'FF      |
|                  | 6          | DENPRO     | Program counter enable   | 1:ON 0:OFF   | R/W        | 1            |           |
|                  | 5          | DENPD      | Phase comparison enable  | 1:ON 0:OFF   | R/W        | 1            |           |
|                  | 4          | DENCP      | Charge pump enable   | 1:ON 0:OFF   | R/W        | 1            |           |
|                  | 3          | DENREF     | S-meter enable   | 1:ON 0:OFF   | R/W        | 1            |           |
|                  | 2          | DENXTAL    | XTAL enable  | 1:ON 0:OFF   | R/W        | 1            |           |
|                  | 1          | DEBDEMO    | Demodulator enable   | 1:ON 0:OFF   | R/W        | 1            |           |
| 04h              | 7          | ENLEVELDET | Capacitor bank control circuit enable  | 1:ON 0:OFF   | R/W        | 0            | h'7F      |
|                  | 6          | ENRFMIX    | RFMIX enable   | 1:ON 0:OFF   | R/W        | 1            |           |
|                  | 5          | ENIFLPF    | IF LPF enable  | 1:ON 0:OFF   | R/W        | 1            |           |
|                  | 4          | ENDET      | Wide band AGC, Narrow band AGC block enable  | 1:ON 0:OFF   | R/W        | 1            |           |
|                  | 3          | ENLNA      | LNA block enable   | 1:ON 0:OFF   | R/W        | 1            |           |
|                  | 2          | DENSMETER  | Reference counter enable   | 1:ON 0:OFF   | R/W        | 1            |           |
|                  | 1          | DLOEN      | Local oscillation enable   | 1:ON 0:OFF   | R/W        | 1            |           |
| 05h              | 7          |            |  |  |            | 0            | h'03      |
|                  | 6          |            |  |  |            | 0            |           |
|                  | 5          |            |  |  |            | 0            |           |
|                  | 4          |            |  |  |            | 0            |           |
|                  | 3          |            |  |  |            | 0            |           |
|                  | 2          |            |  |  |            | 0            |           |
|                  | 1          | DNBAGC     | IF AGC detection selector (Narrow band AGC)  | 1:ON 0:OFF   | R/W        | 1            |           |
| 06h              | 7          | DF0OSC[7]  | Capacitor band value<br>Oscillation frequency adjustment for master time<br>constant setting |  | R/W        | 1            | h'80      |
|                  | 6          | DF0OSC[6]  |  |  | R/W        | 0            |           |
|                  | 5          | DF0OSC[5]  |  |  | R/W        | 0            |           |
|                  | 4          | DF0OSC[4]  |  |  | R/W        | 0            |           |
|                  | 3          | DF0OSC[3]  |  |  | R/W        | 0            |           |
|                  | 2          | DF0OSC[2]  |  |  | R/W        | 0            |           |
|                  | 1          | DF0OSC[1]  |  |  | R/W        | 0            |           |
| 07h              | 7          | DBPFO[7]   | Capacitor bank value<br>Complex BPF F0 adjustment  |  | R/W        | 1            | h'80      |
|                  | 6          | DBPFO[6]   |  |  | R/W        | 0            |           |
|                  | 5          | DBPFO[5]   |  |  | R/W        | 0            |           |
|                  | 4          | DBPFO[4]   |  |  | R/W        | 0            |           |
|                  | 3          | DBPFO[3]   |  |  | R/W        | 0            |           |
|                  | 2          | DBPFO[2]   |  |  | R/W        | 0            |           |
|                  | 1          | DBPFO[1]   |  |  | R/W        | 0            |           |
| 0                | DBPFO[0]   | R/W        | 0  |  |            |              |           |

# LC01707PLF

## Register Map 2

\* HEX value is set by default.

■ : Unused BIT

| Register address | BIT         | Bit name                         | Function   | Bit operation   | Read/Write                | Binary value     | Hex value |     |
|------------------|-------------|----------------------------------|--|---|---------------------------|------------------|-----------|-----|
| 08h              | 7           | D2BPF[7]                         | Capacitor bank value<br>2 <sup>nd</sup> IF BPF f0 adjustment   |   | R/W                       | 1                | h'80      |     |
|                  | 6           | D2BPF[6]                         |  |   | R/W                       | 0                |           |     |
|                  | 5           | D2BPF[5]                         |  |   | R/W                       | 0                |           |     |
|                  | 4           | D2BPF[4]                         |  |   | R/W                       | 0                |           |     |
|                  | 3           | D2BPF[3]                         |  |   | R/W                       | 0                |           |     |
|                  | 2           | D2BPF[2]                         |  |   | R/W                       | 0                |           |     |
|                  | 1           | D2BPF[1]                         |  |   | R/W                       | 0                |           |     |
|                  | 0           | D2BPF[0]                         |  |   | R/W                       | 0                |           |     |
| 09h              | 7           | ■                                | DLL demodulator loop gain setting  |   | R/W                       | 0                | h'17      |     |
|                  | 6           | ■                                |  |   | R/W                       | 0                |           |     |
|                  | 5           | DDEMOG[1]                        |  |   | R/W                       | 1                |           |     |
|                  | 4           | DDEMOG[0]                        |  |   | R/W                       | 0                |           |     |
|                  | 3           | DMONOC[3]                        |  |   | Mono multi center setting | R/W              |           | 0   |
|                  | 2           | DMONOC[2]                        |  |   |                           | R/W              |           | 1   |
|                  | 1           | DMONOC[1]                        |  |   |                           | R/W              |           | 1   |
| 0                | DMONOC[0]   | R/W                              | 1  |   |                           |                  |           |     |
| 0Ah              | 7           | ■                                |  |   | R/W                       | 0                | h'02      |     |
|                  | 6           | ■                                |  |   | R/W                       | 0                |           |     |
|                  | 5           | ■                                |  |   | R/W                       | 0                |           |     |
|                  | 4           | ■                                |  |   | R/W                       | 0                |           |     |
|                  | 3           | ■                                |  |   | R/W                       | 0                |           |     |
|                  | 2           | ■                                |  |   | R/W                       | 0                |           |     |
|                  | 1           | ENIMRSSI                         |  |   | XTAL OSC FET size setting | 1:Normal 0:Twice |           | R/W |
| 0                | DIQC        | Complex BPF injection changeover | 1:lower 0:upper  | R/W   | 0                         |                  |           |     |
| 0Bh              | 7           | ■                                | IQ balance adjustment  |   | R/W                       | 0                | h'40      |     |
|                  | 6           | DBL[6]                           |  |   | R/W                       | 1                |           |     |
|                  | 5           | DBL[5]                           |  |   | R/W                       | 0                |           |     |
|                  | 4           | DBL[4]                           |  |   | R/W                       | 0                |           |     |
|                  | 3           | DBL[3]                           |  |   | R/W                       | 0                |           |     |
|                  | 2           | DBL[2]                           |  |   | R/W                       | 0                |           |     |
|                  | 1           | DBL[1]                           |  |   | R/W                       | 0                |           |     |
| 0                | DBL[0]      | R/W                              | 0  |   |                           |                  |           |     |
| 0Ch              | 7           | ■                                | Charge pump output current value setting   | 0:0.1mA 1:0.2mA 2:0.3mA 3:0.4mA 4:0.5mA 5:0.6mA 6:0.7mA<br>7:0.8mA 8:0.9mA A:1mA B:1.1mA C:1.2mA D: unused<br>E: unused F: unused | R/W                       | 0                | h'0A      |     |
|                  | 6           | ■                                |  |   | R/W                       | 0                |           |     |
|                  | 5           | ■                                |  |   | R/W                       | 0                |           |     |
|                  | 4           | ■                                |  |   | R/W                       | 0                |           |     |
|                  | 3           | DCP1REF[3]                       |  |   | R/W                       | 1                |           |     |
|                  | 2           | DCP1REF[2]                       |  |   | R/W                       | 0                |           |     |
| 0Dh              | 7           | DPCNT_L[7]                       | N value of frequency divider (low 8 bits)<br>N value of frequency divider =<br>((4 × received frequency) ÷ (4 × 1 <sup>st</sup> IF frequency)) /<br>(4 channel × step frequency)<br>* 1 <sup>st</sup> IF frequency is 1.2MHz |   | R/W                       | *                | h**       |     |
|                  | 6           | DPCNT_L[6]                       |  |   | R/W                       | *                |           |     |
|                  | 5           | DPCNT_L[5]                       |  |   | R/W                       | *                |           |     |
|                  | 4           | DPCNT_L[4]                       |  |   | R/W                       | *                |           |     |
|                  | 3           | DPCNT_L[3]                       |  |   | R/W                       | *                |           |     |
|                  | 2           | DPCNT_L[2]                       |  |   | R/W                       | *                |           |     |
|                  | 1           | DPCNT_L[1]                       |  |   | R/W                       | *                |           |     |
| 0                | DPCNT_L[0]  | R/W                              | *  |   |                           |                  |           |     |
| 0Eh              | 7           | DPCNT_H[7]                       | N value of frequency divider (high 8 bits)   |   | R/W                       | *                | h**       |     |
|                  | 6           | DPCNT_H[6]                       |  |   | R/W                       | *                |           |     |
|                  | 5           | DPCNT_H[5]                       |  |   | R/W                       | *                |           |     |
|                  | 4           | DPCNT_H[4]                       |  |   | R/W                       | *                |           |     |
|                  | 3           | DPCNT_H[3]                       |  |   | R/W                       | *                |           |     |
|                  | 2           | DPCNT_H[2]                       |  |   | R/W                       | *                |           |     |
|                  | 1           | DPCNT_H[1]                       |  |   | R/W                       | *                |           |     |
| 0                | DPCNT_H[0]  | R/W                              | *  |   |                           |                  |           |     |
| 0Fh              | 7           | DCBANK_L[7]                      | Local oscillator capacitor bank setting (low 8 bits)   |   | R/W                       | 0                | h'00      |     |
|                  | 6           | DCBANK_L[6]                      |  |   | R/W                       | 0                |           |     |
|                  | 5           | DCBANK_L[5]                      |  |   | R/W                       | 0                |           |     |
|                  | 4           | DCBANK_L[4]                      |  |   | R/W                       | 0                |           |     |
|                  | 3           | DCBANK_L[3]                      |  |   | R/W                       | 0                |           |     |
|                  | 2           | DCBANK_L[2]                      |  |   | R/W                       | 0                |           |     |
|                  | 1           | DCBANK_L[1]                      |  |   | R/W                       | 0                |           |     |
| 0                | DCBANK_L[0] | R/W                              | 0  |   |                           |                  |           |     |

# LC01707PLF

## Register Map 3

\* HEX value is set by default.

■ : Unused BIT

| Register address | BIT          | Bit name     | Function   | Bit operation   | Read/Write  | Binary value | Hex value |
|------------------|--------------|--------------|--|---|---|--------------|-----------|
| 10h              | 7            |              |  |   |   | 0            | h'01      |
|                  | 6            |              |  |   |   | 0            |           |
|                  | 5            |              |  |   |   | 0            |           |
|                  | 4            |              |  |   |   | 0            |           |
|                  | 3            |              |  |   |   | 0            |           |
|                  | 2            |              |  |   |   | 0            |           |
|                  | 1            |              |  |   |   | 0            |           |
|                  | 0            | DCBANK_H[8]  | Local oscillator capacitor bank setting (high 1 bit) |   | R/W   | 1            |           |
| 11h              | 7            |              |  |   |   | 0            | h'0F      |
|                  | 6            |              |  |   |   | 0            |           |
|                  | 5            |              |  |   |   | 0            |           |
|                  | 4            | DCBEN        | Unused   |   |   | 0            |           |
|                  | 3            | DLOALC[3]    | Local oscillation level setting                      |   | R/W   | 1            |           |
|                  | 2            | DLOALC[2]    |  | R/W   | 1   |              |           |
|                  | 1            | DLOALC[1]    |  | R/W   | 1   |              |           |
| 0                | DLOALC[0]    | R/W          |  | 1   |   |              |           |
| 12h              | 7            |              |  |   |   | 0            | h'00      |
|                  | 6            | DENIFCOUNT   | Frequency counter (analog block) enable              | 1:ON 0:OFF  | R/W   | 0            |           |
|                  | 5            | DENFOOSC     | f0 detection oscillation circuit enable              | 1:ON 0:OFF  | R/W   | 0            |           |
|                  | 4            | DENIFFREQ    | Logic part reference clock enable                    | 1:ON 0:OFF  | R/W   | 0            |           |
|                  | 3            |              |  |   |   | 0            |           |
|                  | 2            | DSCTCOUNT[2] | Count frequency selection                            | 0:unused 1:1F frequency 2:prescaler frequency<br>3:freacalar frequency 4:f0 detection oscillation frequency<br>5:f0 detection oscillation frequency 6:unused 7:1F frequency | R/W   | 0            |           |
|                  | 1            | DSCTCOUNT[1] |  |   | R/W   | 0            |           |
| 0                | DSCTCOUNT[0] | R/W          |  |   | 0   |              |           |
| 13h              | 7            |              |  |   |   | 0            | h'01      |
|                  | 6            |              |  |   |   | 0            |           |
|                  | 5            |              |  |   |   | 0            |           |
|                  | 4            |              |  |   |   | 0            |           |
|                  | 3            |              |  |   |   | 0            |           |
|                  | 2            | CTE          | Counter start trigger                                | 1:ON (frequency counter start) Charge to 0 automatically  | R/W   | 0            |           |
| 14h              | 1            | GT[1]        | Frequency counter gate time selection                | 0:4ms 1:8ms 2:32ms 3:64ms   | R/W   | 0            | h'00      |
|                  | 0            | GT[0]        |  |   | R/W   | 1            |           |
|                  | 7            | LOFQ_L[7]    |  |   | LO_COUNT value (low 8 bits)<br>Measurement frequency = counter value / GT[ms] | R            |           |
| 6                | LOFQ_L[6]    | R            | *  |   |   |              |           |
| 5                | LOFQ_L[5]    | R            | *  |   |   |              |           |
| 4                | LOFQ_L[4]    | R            | *  |   |   |              |           |
| 3                | LOFQ_L[3]    | R            | *  |   |   |              |           |
| 2                | LOFQ_L[2]    | R            | *  |   |   |              |           |
| 1                | LOFQ_L[1]    | R            | *  |   |   |              |           |
| 15h              | 7            | LOFQ_H[7]    | LO_COUNT value (upper 8 bits)                        | R   | *   | h'00         |           |
|                  | 6            | LOFQ_H[6]    |  | R   | *   |              |           |
|                  | 5            | LOFQ_H[5]    |  | R   | *   |              |           |
|                  | 4            | LOFQ_H[4]    |  | R   | *   |              |           |
|                  | 3            | LOFQ_H[3]    |  | R   | *   |              |           |
|                  | 2            | LOFQ_H[2]    |  | R   | *   |              |           |
|                  | 1            | LOFQ_H[1]    |  | R   | *   |              |           |
|                  | 0            | LOFQ_H[0]    |  | R   | *   |              |           |
| 16h              | 7            |              |  |   |   | 0            | h'10      |
|                  | 6            |              |  |   |   | 0            |           |
|                  | 5            | COUNTSEL     |  |   |   | 0            |           |
|                  | 4            | LOCKDETSEL   |  |   |   | 1            |           |
|                  | 3            | LOCKDET_DIG  |  |   |   | 0            |           |
|                  | 2            | LOCKDET      | LOCK detection                                       | 1:LOCK 0:UNLOCK   | R/W   | 0            |           |
|                  | 1            | PHLEVEL[1]   | Charge pump voltage level detection                  | 0:less than 0.5V 1:0.5V to 2.8V 2:Unused 3:more than 2.8V   | R/W   | 0            |           |
|                  | 0            | PHLEVEL[0]   |  |   | R/W   | 0            |           |
| 17h              | 7            |              |  |   |   | *            | h'0*      |
|                  | 6            |              |  |   |   | *            |           |
|                  | 5            |              |  |   |   | *            |           |
|                  | 4            |              |  |   |   | *            |           |
|                  | 3            | IMRSSI[3]    | Reset detection circuit                              | 0:reset 1:reset cancellation  | R   | *            |           |
|                  | 2            | IMRSSI[2]    |  |   | R   | *            |           |
| 1                | IMRSSI[1]    | R            |  |   | *   |              |           |
| 0                | IMRSSI[0]    | R            |  |   | *   |              |           |

# LC01707PLF

## Register Map 4

\* HEX value is set by default.

■ : Unused BIT

| Register address | BIT | Bit name     | Function   | Bit operation   | Read/Write  | Binary value | Hex value |
|------------------|-----|--------------|--|---|---|--------------|-----------|
| 18h              | 7   |              |  |   |   | 0            | h**       |
|                  | 6   | DRS[6]       | S-meter detection level  | Detection range can be changed by setting to DNGA (02h) | R   | *            |           |
|                  | 5   | DRS[5]       |  |   | R   | *            |           |
|                  | 4   | DRS[4]       |  |   | R   | *            |           |
|                  | 3   | DRS[3]       |  |   | R   | *            |           |
|                  | 2   | DRS[2]       |  |   | R   | *            |           |
|                  | 1   | DRS[1]       |  |   | R   | *            |           |
|                  | 0   | DRS[0]       |  |   | R   | *            |           |
| 19h              | 7   | IFCOUNT_L[7] |  |   | IF count value (low 8 bits)<br>2 <sup>nd</sup> IF frequency measurement results |              | R         |
|                  | 6   | IFCOUNT_L[6] | R  | *   |   |              |           |
|                  | 5   | IFCOUNT_L[5] | R  | *   |   |              |           |
|                  | 4   | IFCOUNT_L[4] | R  | *   |   |              |           |
|                  | 3   | IFCOUNT_L[3] | R  | *   |   |              |           |
|                  | 2   | IFCOUNT_L[2] | R  | *   |   |              |           |
|                  | 1   | IFCOUNT_L[1] | R  | *   |   |              |           |
|                  | 0   | IFCOUNT_L[0] | R  | *   |   |              |           |
| 1Ah              | 7   | IFCOUNT_H[7] | IF count value (high 8 bits)   |   | R   | *            | h**       |
|                  | 6   | IFCOUNT_H[6] |  | R   | *   |              |           |
|                  | 5   | IFCOUNT_H[5] |  | R   | *   |              |           |
|                  | 4   | IFCOUNT_H[4] |  | R   | *   |              |           |
|                  | 3   | IFCOUNT_H[3] |  | R   | *   |              |           |
|                  | 2   | IFCOUNT_H[2] |  | R   | *   |              |           |
|                  | 1   | IFCOUNT_H[1] |  | R   | *   |              |           |
|                  | 0   | IFCOUNT_H[0] |  | R   | *   |              |           |
| 1Bh              | 7   | IMCOUNT_L[7] | Unused   |   | R   | *            | h**       |
|                  | 6   | IMCOUNT_L[6] |  | R   | *   |              |           |
|                  | 5   | IMCOUNT_L[5] |  | R   | *   |              |           |
|                  | 4   | IMCOUNT_L[4] |  | R   | *   |              |           |
|                  | 3   | IMCOUNT_L[3] |  | R   | *   |              |           |
|                  | 2   | IMCOUNT_L[2] |  | R   | *   |              |           |
|                  | 1   | IMCOUNT_L[1] |  | R   | *   |              |           |
|                  | 0   | IMCOUNT_L[0] |  | R   | *   |              |           |
| 1Ch              | 7   | IMCOUNT_H[7] | Unused   |   | R   | *            | h**       |
|                  | 6   | IMCOUNT_H[6] |  | R   | *   |              |           |
|                  | 5   | IMCOUNT_H[5] |  | R   | *   |              |           |
|                  | 4   | IMCOUNT_H[4] |  | R   | *   |              |           |
|                  | 3   | IMCOUNT_H[3] |  | R   | *   |              |           |
|                  | 2   | IMCOUNT_H[2] |  | R   | *   |              |           |
|                  | 1   | IMCOUNT_H[1] |  | R   | *   |              |           |
|                  | 0   | IMCOUNT_H[0] |  | R   | *   |              |           |
| 1Dh              | 7   | F0_L[7]      | f0 detection oscillation frequency count value (low 8 bits)<br>Frequency measurement result for master time constant setting |   | R   | *            | h**       |
|                  | 6   | F0_L[6]      |  | R   | *   |              |           |
|                  | 5   | F0_L[5]      |  | R   | *   |              |           |
|                  | 4   | F0_L[4]      |  | R   | *   |              |           |
|                  | 3   | F0_L[3]      |  | R   | *   |              |           |
|                  | 2   | F0_L[2]      |  | R   | *   |              |           |
|                  | 1   | F0_L[1]      |  | R   | *   |              |           |
|                  | 0   | F0_L[0]      |  | R   | *   |              |           |
| 1Eh              | 7   | F0_H[7]      | f0 detection oscillation frequency count value (high 8 bits)   |   | R   | *            | h**       |
|                  | 6   | F0_H[6]      |  | R   | *   |              |           |
|                  | 5   | F0_H[5]      |  | R   | *   |              |           |
|                  | 4   | F0_H[4]      |  | R   | *   |              |           |
|                  | 3   | F0_H[3]      |  | R   | *   |              |           |
|                  | 2   | F0_H[2]      |  | R   | *   |              |           |
|                  | 1   | F0_H[1]      |  | R   | *   |              |           |
|                  | 0   | F0_H[0]      |  | R   | *   |              |           |
| 1Fh              | 7   |              |  |   |   | 0            | h'02      |
|                  | 6   |              |  |   |   | 0            |           |
|                  | 5   |              |  |   |   | 0            |           |
|                  | 4   |              |  |   |   | 0            |           |
|                  | 3   |              |  |   |   | 0            |           |
|                  | 2   | DOUTSEL      | Register for TEST  |   | R/W   | 0            |           |
|                  | 1   | DCNTEST      | Register for TEST  |   | R/W   | 1            |           |
|                  | 0   | DOUTTEST     | Register for TEST  |   | R/W   | 0            |           |

Continued on next page.

# LC01707PLF

Continued from preceding page.

| Register address | BIT         | Bit name  | Function   | Bit operation   | Read/Write | Binary value | Hex value |
|------------------|-------------|---|--|---|------------|--------------|-----------|
| 20h              | 7           |   |  |   |            | 0            | h'0A      |
|                  | 6           | ERR2  | Local oscillator capacitor bank control error flag 2                               |   | R/W        | 0            |           |
|                  | 5           | ERR1  | Local oscillator capacitor bank control error flag 1                               |   | R/W        | 0            |           |
|                  | 4           | DCOSEL2   | Local oscillator capacitor bank value changeover                                   | 1:cap bank control value 0:1°C input value  | R/W        | 0            |           |
|                  | 3           | DCOSEL1   | Local oscillator capacitor bank control process changeover                         | 1:correcting process after sequential comparison<br>0:No correcting process after sequential comparison | R/W        | 1            |           |
|                  | 2           | DCOSEL0   | Local oscillator capacitor bank control process changeover (micro alignment)       | 1:micro adjustment process 0:No micro adjustment process  | R/W        | 0            |           |
|                  | 1           | DWAITSEL[1]   | PLL operation check wait time after local oscillator capacitor bank adjustment     | 0:200µs 1: 400µs 2:800µs 3:1600µs   | R/W        | 1            |           |
| 0                | DWAITSEL[0] | R/W   |  |   | 0          |              |           |
| 21h              | 7           |   |  |   |            | 0            | h'0A      |
|                  | 6           |   |  |   |            | 0            |           |
|                  | 5           | DENINT  | Register for TEST  |   | R/W        | 0            |           |
|                  | 4           | MASKSEL   | Register for TEST  |   | R/W        | 0            |           |
|                  | 3           | LOSEL   | Register for TEST  |   | R/W        | 1            |           |
|                  | 2           | INTPH   | Register for TEST  |   | R/W        | 0            |           |
|                  | 1           | INTIM   | Register for TEST  |   | R/W        | 1            |           |
| 22h              | 0           | INTLO   | Register for TEST  |   | R/W        | 0            | h'15      |
|                  | 7           | TESTSEL[2]  | Register for TEST  |   | R/W        | 0            |           |
|                  | 6           | TESTSEL[1]  | Register for TEST  |   | R/W        | 0            |           |
|                  | 5           | TESTSEL[0]  | Register for TEST  |   | R/W        | 0            |           |
|                  | 4           | DSW   | PLL loop filter ON/OFF   | 1:ON 0:OFF  | R/W        | 1            |           |
|                  | 3           | TIMESEL2[1]   | Local oscillator capacitor bank control correcting circuit operation clock setting | 0:200µs 1: 400µs 2:800µs 3:1600µs   | R/W        | 0            |           |
|                  | 2           | TIMESEL2[0]   |  |   | R/W        | 1            |           |
| 1                | TIMESEL[1]  | Local oscillator capacitor bank control sequential comparison control operation clock setting | 0:10µs 1:20µs 2:40µs 3:80µs  | R/W   | 0          |              |           |
| 0                | TIMESEL[0]  |   |  | R/W   | 1          |              |           |

## SD pin specification

SD voltage level  $V_{DD}$ : supply voltage

| item                      | min          | max      | unit |
|---------------------------|--------------|----------|------|
| High level output voltage | $V_{DD}-0.8$ | $V_{DD}$ | V    |
| Low level output voltage  | 0            | 0.4      | V    |

- SANYO Semiconductor Co.,Ltd. assumes no responsibility for equipment failures that result from using products at values that exceed, even momentarily, rated values (such as maximum ratings, operating condition ranges, or other parameters) listed in products specifications of any and all SANYO Semiconductor Co.,Ltd. products described or contained herein.
- SANYO Semiconductor Co.,Ltd. strives to supply high-quality high-reliability products, however, any and all semiconductor products fail or malfunction with some probability. It is possible that these probabilistic failures or malfunction could give rise to accidents or events that could endanger human lives, trouble that could give rise to smoke or fire, or accidents that could cause damage to other property. When designing equipment, adopt safety measures so that these kinds of accidents or events cannot occur. Such measures include but are not limited to protective circuits and error prevention circuits for safe design, redundant design, and structural design.
- In the event that any or all SANYO Semiconductor Co.,Ltd. products described or contained herein are controlled under any of applicable local export control laws and regulations, such products may require the export license from the authorities concerned in accordance with the above law.
- No part of this publication may be reproduced or transmitted in any form or by any means, electronic or mechanical, including photocopying and recording, or any information storage or retrieval system, or otherwise, without the prior written consent of SANYO Semiconductor Co.,Ltd.
- Any and all information described or contained herein are subject to change without notice due to product/technology improvement, etc. When designing equipment, refer to the "Delivery Specification" for the SANYO Semiconductor Co.,Ltd. product that you intend to use.
- Upon using the technical information or products described herein, neither warranty nor license shall be granted with regard to intellectual property rights or any other rights of SANYO Semiconductor Co.,Ltd. or any third party. SANYO Semiconductor Co.,Ltd. shall not be liable for any claim or suits with regard to a third party's intellectual property rights which has resulted from the use of the technical information and products mentioned above.

This catalog provides information as of March, 2012. Specifications and information herein are subject to change without notice.