

25 MHz Fiber Optic Receiver

Type OPF542

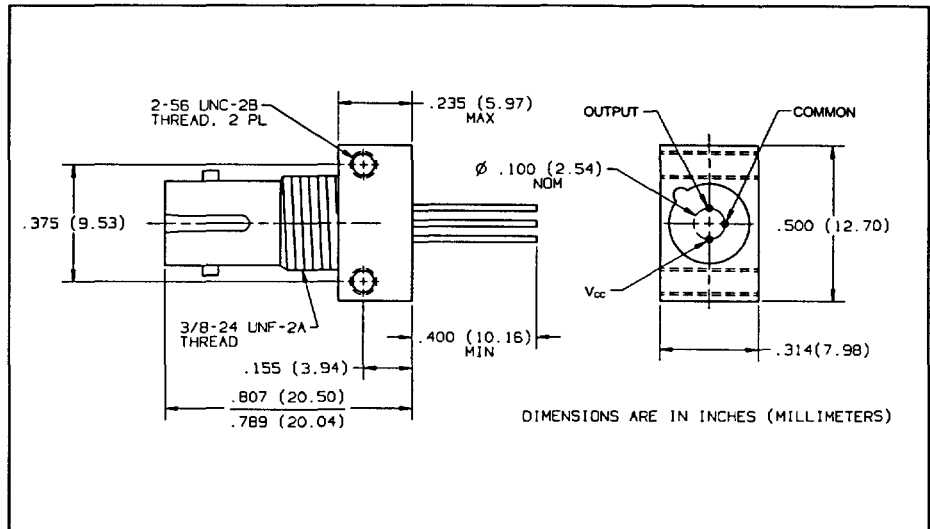
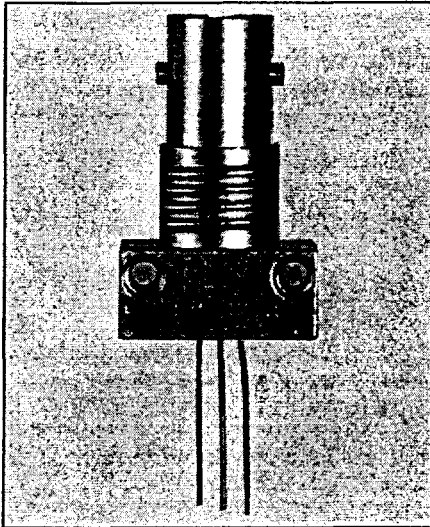

Features

- Component pre-mounted and ready to use
- Pre-tested with fiber to assure performance
- Popular style receptacle

Description

The output of the receiver is an analog, low impedance, voltage source capable of driving an amplifier or level translating circuitry for use on various data formats and data rates up to 35 MBaud.

The receiver is comprised of a high speed, low noise, photodiode coupled to a transimpedance amplifier which produces an output voltage proportional to the input light amplitude. This hybrid approach solves many of the problems of high speed data link designs by placing a pre-amplifier close to the photodiode. The level amplification produced by the transimpedance amplifier makes the output signal much less susceptible to interference which is a problem often found at high data rates and in high EMI environments.

Absolute Maximum Ratings (T_A = 25° C unless otherwise noted)

Storage Temperature	-55° C to +115° C
Operating Temperature	-40° C to +85° C
Lead Soldering Temperature (for 10 sec.)	260° C
Supply Voltage	-0.5 to 7.0 V

Type OPF542

Electrical Characteristics ($T_A = 25^\circ\text{C}$ unless otherwise noted)

$4.75 \leq V_{CC} \leq 5.25$, $R_{LOAD} = 511 \Omega$, Fiber Sizes ≤ 100 Microns, N.A. ≤ 0.35

SYMBOL	PARAMETERS	MIN	TYP	MAX	UNITS	TEST CONDITIONS
R_P	Responsivity	6.5 5.8	9.3	12.5 14.1	mV/ μ W mV/ μ W	at 840 nm at 840 nm, $-40^\circ\text{C} \leq T_A \leq +85^\circ\text{C}$
V_{NO}	RMS Output Noise Voltage		0.30	0.36 0.43	mV mV	$P_R = 0 \mu\text{W}$ $P_R = 0 \mu\text{W}$, $-40^\circ\text{C} \leq T_A \leq +85^\circ\text{C}$
P_N	Equivalent Optical Noise Input Power		-44.9 0.032	-40.9 0.082	dBm μ W	
P_R	Peak Input Power			-13.2 48 -14.7 34	dBm μ W dBm μ W	$T_A = 25^\circ\text{C}$ $T_A = 25^\circ\text{C}$ $-40^\circ\text{C} \leq T_A \leq +85^\circ\text{C}$ $-40^\circ\text{C} \leq T_A \leq +85^\circ\text{C}$
I_{CC}	Power Supply Current		3.4	6.0	mA	$R_{LOAD} = \infty$
t_r, t_f	Rise Time, Fall Time (10% to 90%)		14	19.5	ns	$P_R = 10 \mu\text{W Peak}$, $R_{LOAD} = 511 \Omega$, $C_{LOAD} = 13 \text{ pF}$
PWD	Pulse Width Distortion			2	ns	$P_R = 40 \mu\text{W Peak}$, $R_{LOAD} = 511 \Omega$, $C_{LOAD} = 13 \text{ pF}$