

NOTES:

1. MATERIAL: .020 THICK, ELECTRO-GALVANIZED ZINC ^① PLATED STEEL, #3 TEMPER (1/4 HARD) PER ETCO METAL CODE 0-0109.
2. MATERIAL: .020 THICK, S430 STAINLESS STEEL, BRIGHT ANNEALED,
3. PARTS MAY BE COATED WITH A LIGHT FILM OF LUBRICATION USED IN THE MANUFACTURING PROCESS.
4. WIRE RANGE: 8mm.

P/C	DESCRIPTION	MAT'L	CLIP
15066	SP19-BZS-S	NOTE 1	SCA4-B
15065	SP19-SS-S	NOTE 2	SCA4-B
	SP19-SS-S-SC	NOTE 2	SCA4-SS

Rev.	Description of Change/ SCN#	Date
1	ECR# 4870 SCJ Redrawn in SW from ACAD Org.Eng.Dwg.Date: 12/18/89	5/02/19

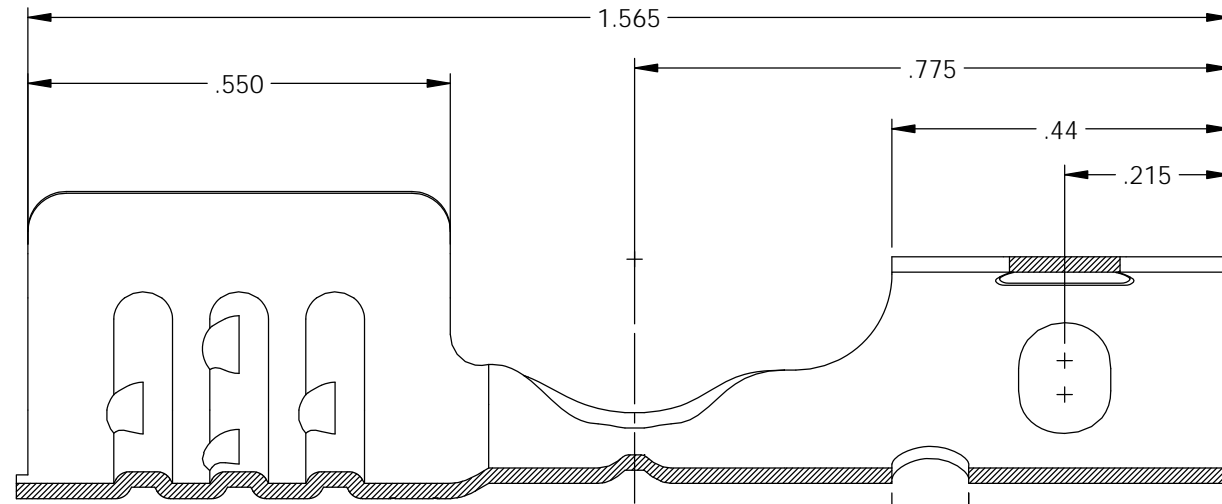
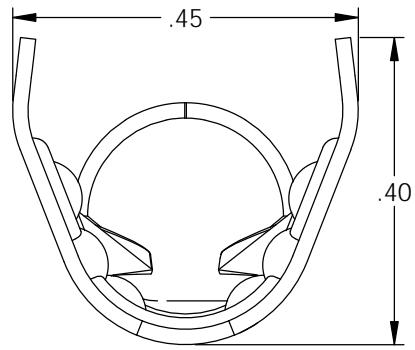
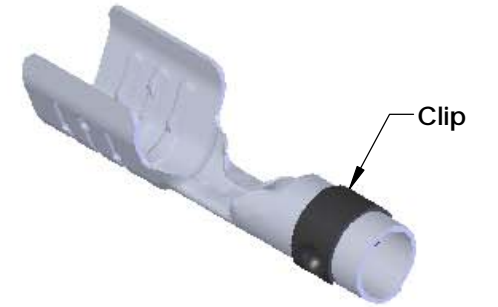
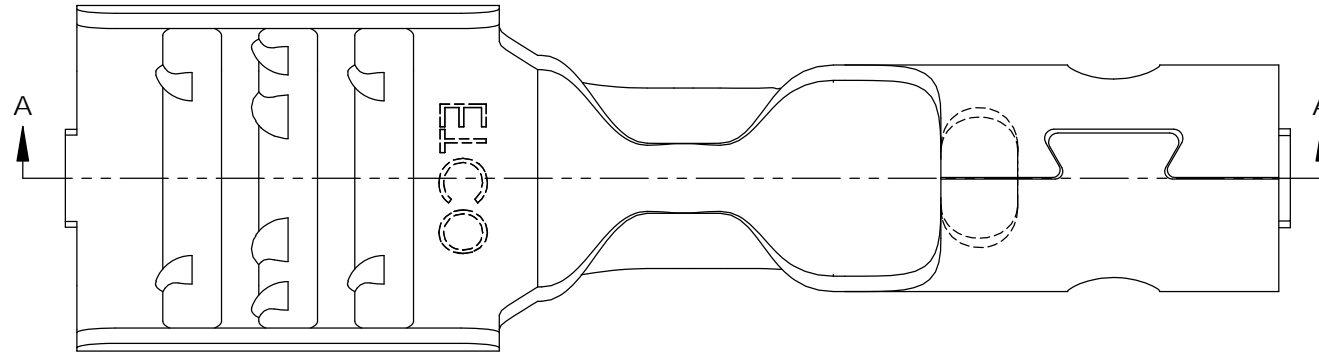

SECTION A-A
SCALE 4 : 1

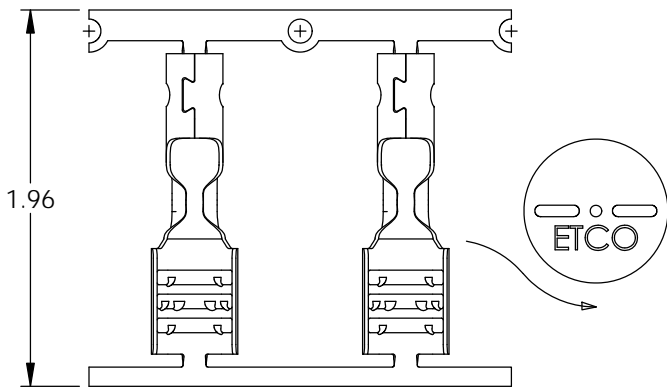
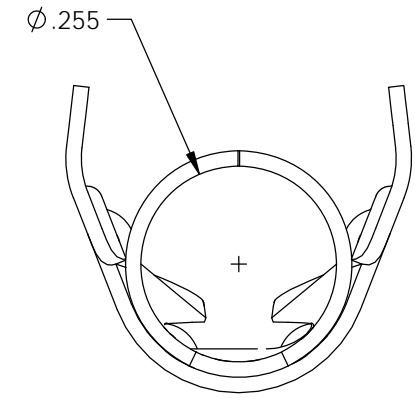

DIRECTION EXITING TOOL,
EARS UP, TO THE FRONT

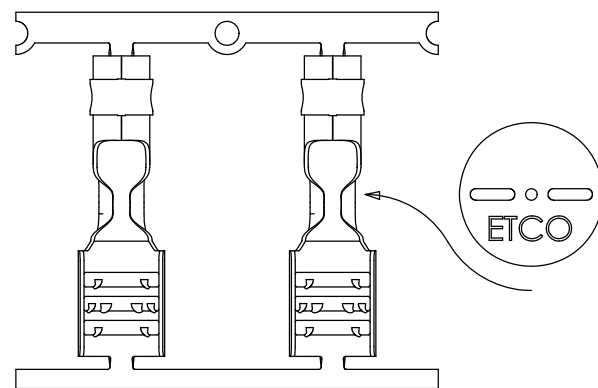

DIRECTION TOWARD APPLICATION,
EARS UP TO THE BACK, FROM RIGHT

THIS PRINT IS THE PROPERTY OF ETCO INCORPORATED. NO PART OF THIS DESIGN MAY BE USED IN ANY WAY WITHOUT WRITTEN CONSENT FROM ETCO INCORPORATED.

UNCONTROLLED COPY

<p>THIRD ANGLE PROJECTION TOLERANCES UNLESS OTHERWISE SPECIFIED INCHES: .XX - ±.030 .XXX - ±.015 ANGLES: ±5°</p>	<p>TOOL NO. 2165</p>	<p>Title: Spark Plug Terminal</p>	
		<p>DO NOT SCALE DWG.</p>	<p>Drawn By: S.Johnson</p>
<p>ETCO Incorporated Engineered Products 25 Bellows Street Warwick, RI 02888 Phone: (401) 467-2400 Fax: (401) 467-9230 www.ETCO.com</p>		<p>Design Control By: ETCO</p>	<p>Scale: 4X Size B</p>
		<p>Dwg. No.: SP19-S cust</p>	