

Features

- Low Cost Design
- Rugged, Modular, Hybrid Construction
- Phase Locks VCO and DROs up to 20 GHz
- Wide Frequency Range
- Available for Oscillator Signal Levels from -3 dBm to +13 dBm
- Hermetic Package Available

Description

Alpha's series of Sampling Phase Detectors (SPD's) consist of a hybrid assembly of an SRD comb generator, coupling capacitors and microwave mixer diodes. This module makes an inexpensive way of phase locking a commercial VCO source to a low frequency stable reference. Each part in the series is optimized to operate in standard narrow band commercial systems. All units handle reference frequencies in the 50 to 500 MHz band. Component selection within Alpha allows us to minimize beat note output.

It is easiest to think of the SPD in its two constituent forms; a comb generator and subharmonic mixer.

The comb generator portion consists of the external reference, amplifier and impedance transformer. The external circuit matches into the low impedance of the SRD portion of the SPD. Careful attention to matching by setting the right transformer ratio, detuning the

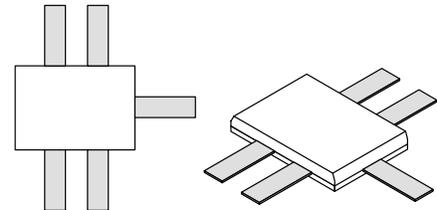

circuit with shunt capacitors will result in larger amplitude beat note signals.

The subharmonic mixer portion is the Schottky series pair. Various drive levels can be used to tailor intermodulation and beat note performance.

The basic operation of a SPD is when the reference signal is fed into the SRD. This sets up a strong pulse, rich in harmonics that is used to strobe the mixer diodes on. The balanced mixer design converts the sampled oscillator signal and matching harmonics into an IF beat note. This signal can then be used in feedback loop to correct tuning voltage on the VCO.

Typical applications include phase locking of oscillators in TVRO, VSAT, DBS and telecommunications markets.

Leadless chip carriers and surface mount versions are also available

Electrical Specifications at 25°C

Part Number	Microwave Signal Level dBm	Operating Frequency GHz	Monolithic Schottky Diode Pair			Beam Lead Coupling Capacitors C_L pf	Beam Lead Step Recovery Diode			
			V_F @ 1 mA mV	R_S Ω	C_J @ 0V pf		C_J @ 6V pf	T_L nS	T_T pS	V_B V
			Typ.	Typ.	Typ.		Typ.	Typ.	Typ.	Min.
SPD2835-211	-3 to 0	4	240	3	0.40	1.0	0.35	25	50	14
SPD2826-211		12	275	6	0.25	0.6	0.35	25	50	14
SPD2827-211		18	300	10	0.12	0.5	0.35	25	50	14
SPD2828-211		20	325	15	0.08	0.5	0.35	25	50	14
SPD2050-211	0 to +3	4	350	3	0.40	1.0	0.35	25	50	14
SPD2829-211		12	375	6	0.25	0.6	0.35	25	50	14
SPD2830-211		18	400	10	0.12	0.5	0.35	25	50	14
SPD2831-211		20	450	15	0.08	0.5	0.35	25	50	14
SPD2092-211	0 to +13	4	550	3	0.40	1.0	0.35	25	50	14
SPD2093-211		12	575	6	0.25	0.6	0.35	25	50	14
SPD2832-211		18	625	10	0.12	0.5	0.35	25	50	14
SPD2833-211		20	675	15	0.08	0.5	0.35	25	50	14

Any of the above can be made in hermetic packages. The part number series is SPDXXX-217.

Typical Performance Data SPD 3465-18 Low Drive

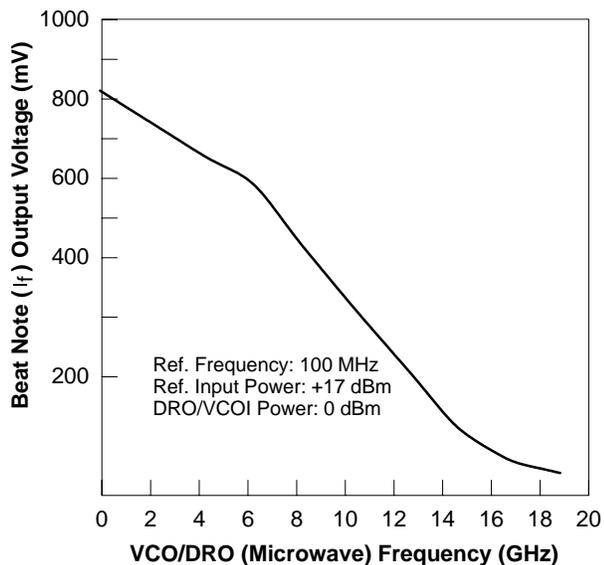

Suggested Circuit Configuration

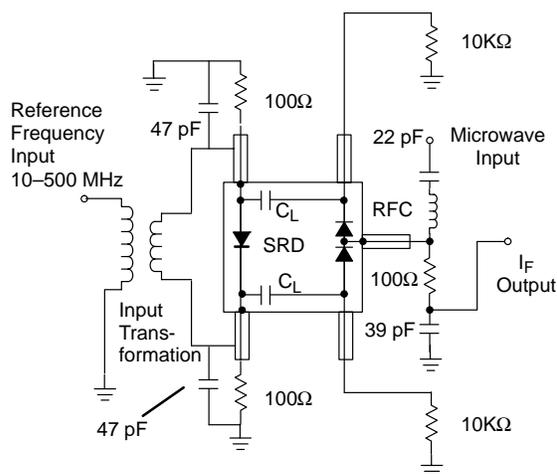

1. Input transformer 10:1 turns ratio low impedance at SRD; MCL617 or equivalent.

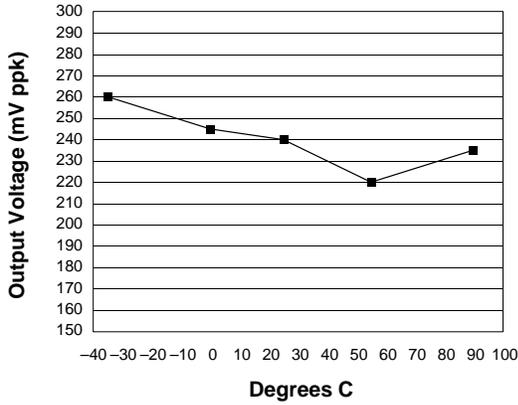

Beat Note Voltage vs Temperature
(Frequency 100 MHz, Ref Power +10 dBm)

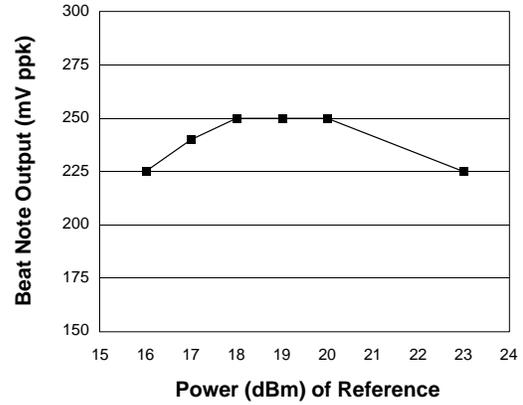

Beat Note Voltage vs Power
(100 MHz Reference)

Outline Drawing

211 (Epoxy)

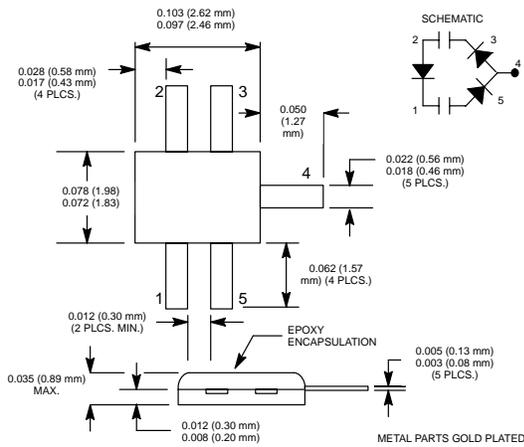

217 (Hermetic)

