

SPEAKER PHONE SYSTEM

DESCRIPTION

The CS262 is a monolithic integrated circuit designed for use in a speakerphone system. It is a simplex system utilizing unique circuitry to closely approximate the characteristics of a duplex system without the associated feedback problems.

The system includes two attenuator/gain cells, transmit/receive logarithmic level detectors, level comparator and associated control circuitry.

Novel circuitry is used to minimize transmitted background noise when there are pauses between conversations by providing maximum attenuation when no voice is present.

The circuit may be powered by a wide range of supply voltages, since the CS262 incorporates its own internal shunt regulator of 5.9V (typical).

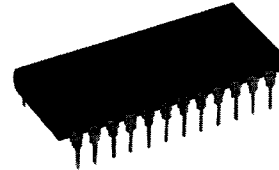

FEATURES:

- Low current drain
- Automatic background noise suppression
- Wide dynamic range
- Independent control of transmit/receive levels

APPLICATIONS:

- Speakerphones
- Intercoms
- Transmitters
- Noise gates
- Voltage controlled amplifiers

PIN CONNECTIONS (TOP VIEW)

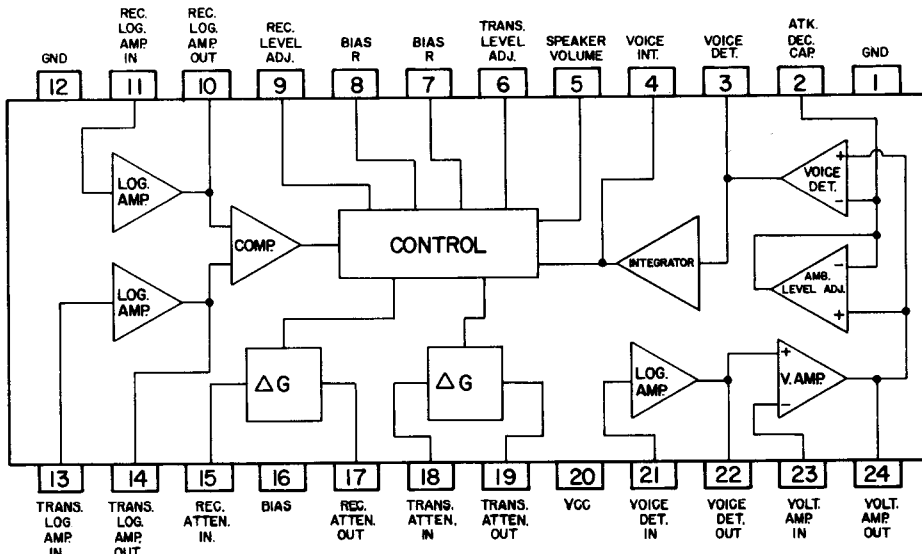

ABSOLUTE MAXIMUM RATINGS

Operating Temperature -25°C to +85°C Storage Temperature -40°C to +150°C

ELECTRICAL CHARACTERISTICS (T_A=25°C) Pin 5=0V, except where noted.

PARAMETER	PIN	TEST CONDITIONS	MIN.	TYP.	MAX.	UNITS
Regulator						
V _{REG}	20	I ₂₀ = 10mA	5.4	5.9	6.4	V
Supply Current	20	V ₂₀ = 5VDC	3.5		7.5	mA
V _{BIAS}	16	V ₂₀ = 5VDC	2.2		2.7	V
Voice Detector Log Amplifier						
Input Voltage	21	V ₂₀ = 5VDC	2.2		2.7	V
V _{OUT} Low Level	22	V ₂₀ = 5VDC V _{IN} = 100mV rms, F = 1kHz		2.50		V
V _{OUT} High Level	22	V ₂₀ = 5VDC V _{IN} = 1V rms, F = 1kHz		2.56		V
Voice Detector						
V _{OUT} High	3	V ₂ = 2V	3.5			V
V _{OUT} Low	3		1.1		1.5	V
Voltage Amplifier						
Input Current	23	V ₂₂ = V ₂₃ = 3.5V			10	μA
Open Voltage Gain	24		40			dB
Voice Detector Integrator						
Input Current	3	V ₃ = 0V	0.5		10	μA
Control Voltage	4	V ₂₀ = 5V, V ₃ = 0V, V ₁₃ = 1V rms		4.8		V
Transmit Log Amplifier						
Input Voltage	13	V ₂₀ = 5VDC	2.2		2.7	V
V _{OUT} Low Level	14	V ₂₀ = 5VDC V _{IN} = 100mV rms, F = 1kHz		2.60		V
V _{OUT} High Level	14	V ₂₀ = 5VDC V _{IN} = 1V rms, F = 1kHz		2.66		V
Receive Log Amplifier						
Input Voltage	11	V ₂₀ = 5VDC	2.2		2.7	V
V _{OUT} Low Level	10	V ₂₀ = 5VDC V _{IN} = 100mV rms, F = 1kHz		2.60		V
V _{OUT} High Level	10	V ₂₀ = 5VDC V _{IN} = 1V rms, F = 1kHz		2.66		V
Transmit/Receive Comparator						
Transmit Input Current	14	V ₁₄ = 3.5V			5	μA
Receive Input Current	11	V ₁₁ = 3.5V			5	μA
Level Control						
Speaker Volume Control Input Current	5				50	μA
V ₆	6	V ₂₀ = 5VDC	0.8		1.5	V
V ₇	7	V ₂₀ = 5VDC	0.8		1.5	V
V ₈	8	V ₂₀ = 5VDC	0.8		1.5	V
V ₉	9	V ₂₀ = 5VDC	0.8		1.5	V
Transmit Attenuator						
Input Voltage	18		2.2		3.0	V
Output Voltage	19		2.4		3.4	V
Delta Output Voltage	19	Switch From Tx to Rx			200	mV
Minimum Attenuation	19	V ₂₀ = 5VDC V ₃ = 5V, V _{IN} = 0.5V rms, F = 1kHz	2		-4	dB
Maximum Attenuation	19	V ₂₀ = 5VDC V ₃ = 0V, V _{IN} = 0.5V rms, F = 1kHz	-21		-30	dB
Distortion	19	V ₃ = 5V, V _{IN} = 0.5V rms, F = 1kHz		1		%
Receive Attenuator						
Input Voltage	15		2.2		3.0	V
Output Voltage	17		2.4		3.4	V
Delta Output Voltage	17	Switch From Rx to Tx			200	mV
Minimum Attenuation	17	V ₅ = 5VDC V _{IN} = 0.5V rms, F = 1kHz	7		1	dB
Maximum Attenuation	17	V _{IN} = 0.5V rms, F = 1kHz	-24		-30	dB
Distortion	17	V ₅ = 5VDC V _{IN} = 0.5V rms, F = 1kHz		1		%

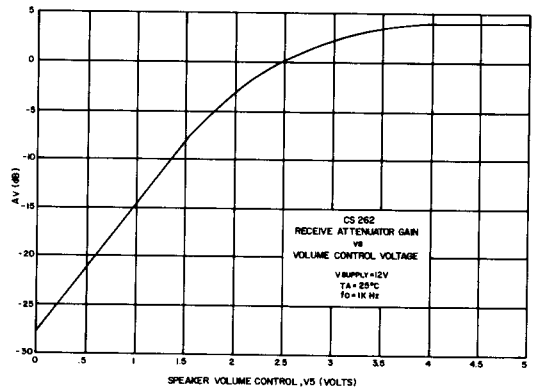
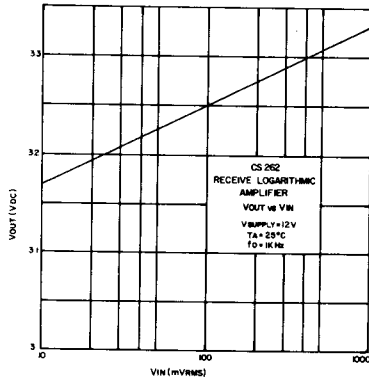
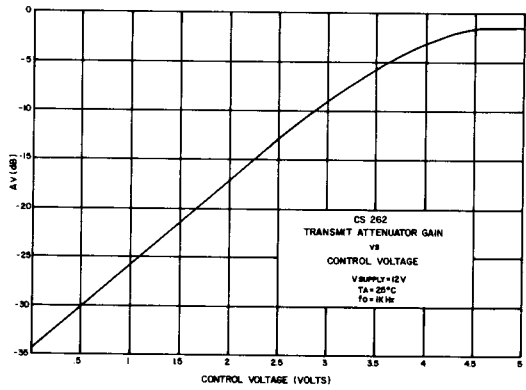
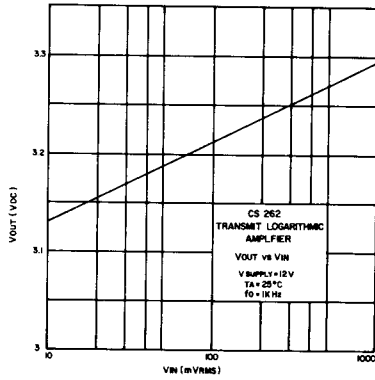

**24 LEAD PLASTIC DIP
DIMENSIONS IN MM(INCHES)**

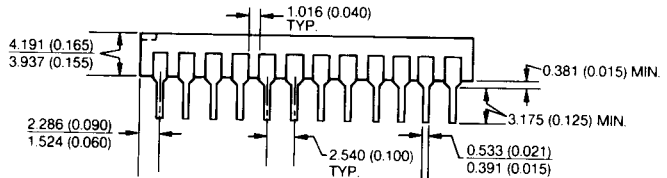
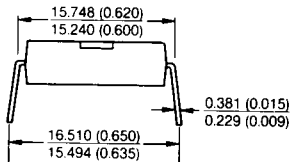
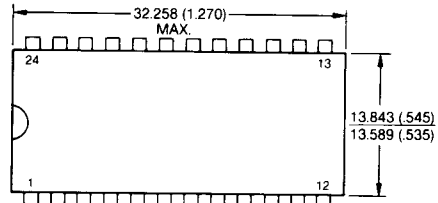

CHERRY
SEMICONDUCTOR

Our Sales Representative in Your Area is:

2000 South County Trail, East Greenwich, Rhode Island 02818
(401) 885-3600
Telex WUI 6817157