

THERMOPILE DETECTORS FOR GAS SENSING

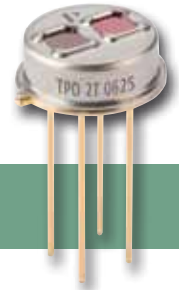

TPD 2T 0625 – Dual Channel Thermopile

Applications

- Gas sensing and monitoring

Features and Benefits

- High sensitivity
- TO-39 metal housing
- Thermistor included
- Two narrow band pass filters

Product Description

This specially designed detector offers dual channel performance in a TO-39 housing with two individual optical windows. Typically one window is fitted with a reference filter G20, where as the other window is fitted with a narrow band pass filter selected for a specific gas (see page 7 of this catalog for available types). The TPD 2T 0625 is also equipped as standard with an internal thermistor as temperature reference for thermopile temperature compensation.

Field of View

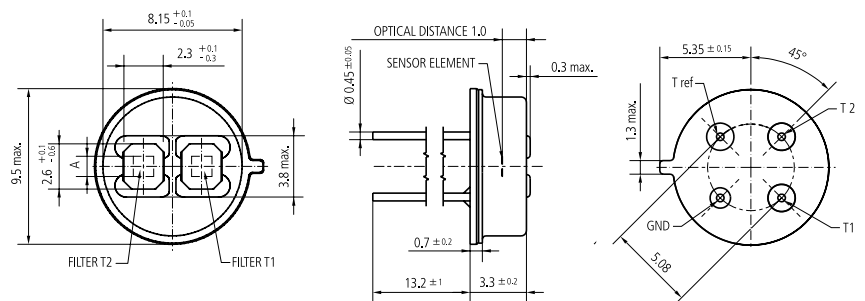
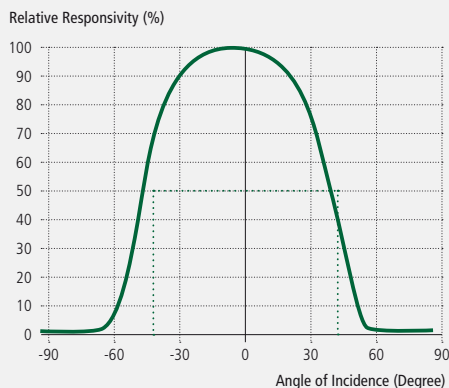

TPD 2T 0625 – Dual Channel Thermopile

Parameter	Symbol	0625	Unit	Remark
Sensitive area	A	1.2 x 1.2	mm	Absorber area
Sensitive area	A	1.4	mm ²	Absorber area
Thermopile resistance	R _{TP}	50 ... 110	kΩ	25° C
Responsivity	R	33	V/W	500° / 1Hz/ without IR-filter
Time constant	t	27	ms	
Noise voltage	V _N	36	nV / √Hz	25° C
Specific detectivity	D*	1.1	10 ⁸ cm ² /Hz/W	25° C
Temp. coefficient of resistance	TC _{RTP}	0.03	% / K	
Temp. coefficient of responsivity	TC _R	-0.05	% / K	
Field of view	FoV	87	Degrees	At 50 % intensity points
Thermistor resistance (25° C)	R ₂₅	100	kΩ	25° C
Thermistor BETA-value	β	3964	K	Defined at 25° C / 100° C