

TSC426
TSC427
TSC428

DUAL POWER MOSFET DRIVER

T.52.13.90

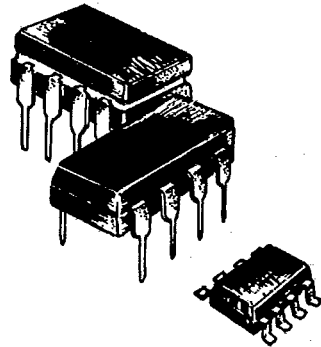

FEATURES

- High Speed Switching ($C_H = 1000\text{pF}$) 30ns
- High Peak Output Current 1.5A
- High Output Voltage Swing $V_S - 25\text{mV}$
 $\text{GND} + 25\text{mV}$
- Low Input Current (Logic "0" or "1") $1\mu\text{A}$
- TTL/CMOS Input Compatible
- Available in Inverting & Non-Inverting Configurations
- Wide Operating Supply Voltage 4.5V to 18V
- Low Power Consumption
 - (Inputs Low) 0.4mA
 - (Inputs High) 8mA
- Single Supply Operation
- Low Output Impedance 6Ω
- Pin Out Equivalent of DS0026 & MMH0026

FUNCTIONAL DIAGRAM

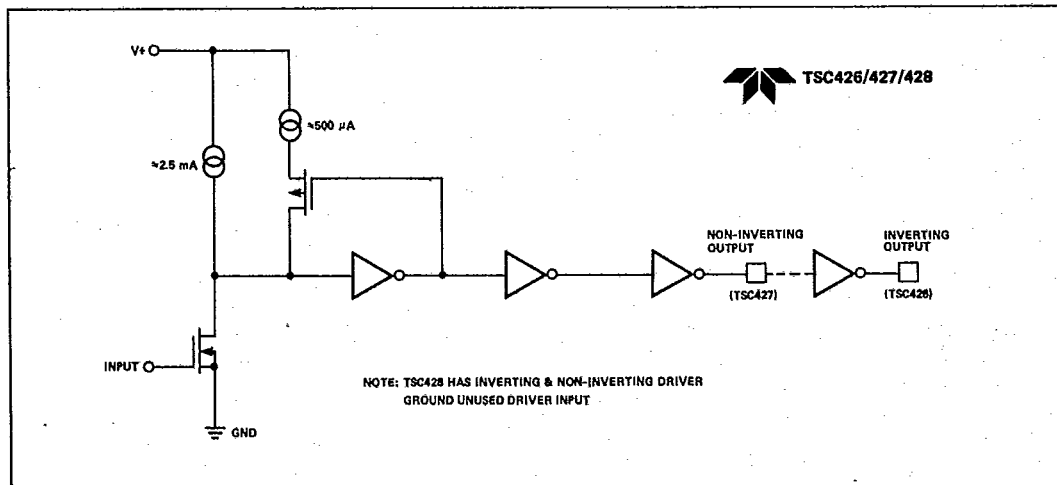

11

TSC426 TSC427 TSC428

DUAL POWER MOSFET DRIVER

T-52-13-90

GENERAL DESCRIPTION

The TSC426/427/428 are dual CMOS high speed drivers. A TTL/CMOS input voltage level is translated into an output voltage level swing equalling the supply. The CMOS output will be within 25 mV of ground or positive supply. Bipolar designs are capable of swinging only within 1 volt of the supply.

The low impedance high current driver outputs will swing a 1000 pf load 18 V in 30 ns. The unique current and voltage drive qualities make the TSC426/427/428 ideal power MOSFET drivers, line drivers and DC to DC converter building blocks.

Input logic signals may equal the power supply voltage. Input current is a low 1 μ A making direct interface to CMOS/BIPOLAR switch mode power supply control integrated circuits possible as well as open collector analog comparators.

Quiescent power supply current is 8 mA maximum. The TSC426 requires 1/5 the current of the pin compatible bipolar DS0026 device. This is important in DC to DC converter applications with power efficiency constraints and high frequency switch mode power supply applications. Quiescent current is typically 6 mA when driving a 1000 pf load 18 V at 100 kHz.

The inverting TSC426 driver is pin compatible with the bipolar DS0026 and MMH0026 devices. The TSC427 is non-inverting; the TSC428 contains an inverting and non-inverting driver.

Pin Configuration

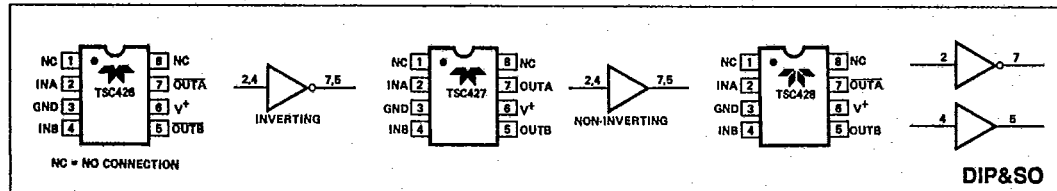

Ordering Information

Part No.	Package	Configuration	Temperature Range
TSC426CPA	8-Pin Plastic Dip	Inverting	0°C to +70°C
TSC426IJA*	8-Pin CerDIP	Inverting	-25°C to +85°C
TSC426MJA*	8-Pin CerDIP	Inverting	-55°C to +125°C
TSC427CPA	8-Pin Plastic Dip	Non-Inverting	0°C to +70°C
TSC427IJA*	8-Pin CerDIP	Non-Inverting	-25°C to +85°C
TSC427MJA*	8-Pin CerDIP	Non-Inverting	-55°C to +125°C
TSC428CPA	8-Pin Plastic DIP	Non-Inv. & Inv.	0°C to +70°C
TSC428IJA*	8-Pin CerDIP	Non-Inv. & Inv.	-25°C to +85°C
TSC428MJA*	8-Pin CerDIP	Non-Inv. & Inv.	-55°C to +125°C
TSC426C/Y	CHIP	Inverting	25°C
TSC427C/Y	CHIP	Non-Inverting	25°C
TSC428C/Y	CHIP	Non-Inv. & Inv.	25°C
TSC426COA	SOIC		0°C to +70°C
TSC427COA	SOIC		0°C to +70°C
TSC428COA	SOIC		0°C to +70°C

* For devices with 125°C, 160 Hour Burn In add /BI to part number suffix.

PRODUCT INFORMATION

T-52-13-90

TSC426
TSC427
TSC428

Absolute Maximum Ratings (Notes 1, 2, 3)

Power Dissipation	
Plastic	500 mW
CerDIP	800 mW
Derating Factors	
Plastic	5.6 mW/°C Above 36°C
CerDIP	6.0 mW/°C
Supply Voltage	20 V

Input Voltage Any Terminal ..	Vs + 0.3 V to Ground -0.3 V
Operating Temperature	
M Version	-55°C to +125°C
I Version	-25°C to +85°C
C Version	0°C to +70°C
Maximum Chip Temperature	+150°C
Storage Temperature	-55°C to +150°C
Lead Temperature (10 Sec)	300°C

TSC426

Electrical Characteristics: TA = 25°C with 4.5 V ≤ Vs ≤ 18 V unless otherwise specified.

TYPE	NO.	SYMBOL	PARAMETER	CONDITIONS	TSC426			UNIT
					MIN	TYP	MAX	
INPUT	1	V _{IH}	Logic 1 Input Voltage		2.4	—	—	V
	2	V _{IL}	Logic 0 Input Voltage		—	—	0.8	V
	3	I _{IN}	Input Current	0 ≤ V _{IN} ≤ Vs	-1	—	1	μA
OUTPUT	4	V _{OH}	High Output Voltage		Vs - 0.025	—	—	V
	5	V _{OL}	Low Output Voltage		—	—	0.025	V
	6	R _O	Output Resistance	V _{IN} = 0.8 V I _{OUT} = 10 mA, Vs = 18 V	—	10	15	Ω
	7	R _O	Output Resistance	V _{IN} = 2.4 V I _{OUT} = 10 mA, Vs = 18 V	—	8	10	Ω
	8	I _{PK}	Peak Output Current		—	1.5	—	A
SWITCHING	9	T _R	Rise Time	Test Figure 1	—	—	30	ns
	10	T _F	Fall Time	Test Figure 1	—	—	20	ns
	11	T _{D1}	Delay Time	Test Figure 1	—	—	40	ns
	12	T _{D2}	Delay Time	Test Figure 1	—	—	75	ns
QUASISTATIC	13	I _S	Power Supply Current	V _{IN} = 3.0 V (Both Inputs)	—	—	8.0	mA
	14	I _S	Power Supply Current	V _{IN} = 0.0 V (Both Inputs)	—	—	0.4	mA

11

TSC426

Electrical Characteristics: Over operating temperature range with 4.5 V ≤ Vs ≤ 18 V unless otherwise specified.

TYPE	NO.	SYMBOL	PARAMETER	CONDITIONS	TSC426			UNIT
					MIN	TYP	MAX	
INPUT	1	V _{IH}	Logic 1 Input Voltage		2.4	—	—	V
	2	V _{IL}	Logic 0 Input Voltage		—	—	0.8	V
	3	I _{IN}	Input Current	0 ≤ V _{IN} ≤ Vs	-10	—	10	μA
OUTPUT	4	V _{OH}	High Output Voltage		Vs - 0.025	—	—	V
	5	V _{OL}	Low Output Voltage		—	—	0.025	V

TSC426

TSC427

TSC428

DUAL POWER MOSFET DRIVER

T-52-13-90

TSC426

Electrical Characteristics: Over operating temperature range with $4.5\text{ V} \leq V_S \leq 18\text{ V}$ unless otherwise specified.

TYPE	NO.	SYMBOL	PARAMETER	CONDITIONS	TSC426			UNIT
					MIN	TYP	MAX	
OUTPUT	6	R _O	Output Resistance	V _{IN} = 0.8 V I _{OUT} = 10 mA, V _S = 18 V	—	13	20	Ω
	7	R _O	Output Resistance	V _{IN} = 2.4 V I _{OUT} = 10 mA, V _S = 18 V	—	8	15	Ω
SWITCHING	8	T _R	Rise Time	Test Figure 1	—	—	60	ns
	9	T _F	Fall Time	Test Figure 1	—	—	40	ns
	10	T _{D1}	Delay Time	Test Figure 1	—	—	60	ns
	11	T _{D2}	Delay Time	Test Figure 1	—	—	120	ns
POWER SUPPLY	12	I _S	Power Supply Current	V _{IN} = 3.0 V (Both Inputs)	—	—	12.0	mA
	13	I _S	Power Supply Current	V _{IN} = 0.0 V (Both Inputs)	—	—	0.6	mA

TSC427

Electrical Characteristics: T_A = 25° C with $4.5\text{ V} \leq V_S \leq 18\text{ V}$ unless otherwise specified.

TYPE	NO.	SYMBOL	PARAMETER	CONDITIONS	TSC427			UNIT
					MIN	TYP	MAX	
INPUT	1	V _{IH}	Logic 1 Input Voltage		2.4	—	—	V
	2	V _{IL}	Logic 0 Input Voltage		—	—	0.8	V
	3	I _{IN}	Input Current	0 ≤ V _{IN} ≤ V _S	-1	—	1	μA
OUTPUT	4	V _{OH}	High Output Voltage		V _S - 0.025	—	—	V
	5	V _{OL}	Low Output Voltage		—	—	0.025	V
	6	R _O	Output Resistance	V _{IN} = 2.4 V I _{OUT} = 10 mA, V _S = 18 V	—	10	15	Ω
	7	R _O	Output Resistance	V _{IN} = 0.8 V I _{OUT} = 10 mA, V _S = 18 V	—	6	10	Ω
SWITCHING	8	I _{PK}	Peak Output Current		—	1.5	—	A
	9	T _R	Rise Time	Test Figure 1	—	—	30	ns
	10	T _F	Fall Time	Test Figure 1	—	—	20	ns
	11	T _{D1}	Delay Time	Test Figure 1	—	—	40	ns
	12	T _{D2}	Delay Time	Test Figure 1	—	—	75	ns
POWER SUPPLY	13	I _S	Power Supply Current	V _{IN} = 3.0 V (Both Inputs)	—	—	8.0	mA
	14	I _S	Power Supply Current	V _{IN} = 0.0 V (Both Inputs)	—	—	0.4	mA

NOTES:

1. Functional operation above the absolute maximum stress ratings is not implied.

2. Static Sensitive device. Unused devices must be stored in conductive material to protect devices from static discharge and static fields.

3. Switching times guaranteed by design.

PRODUCT INFORMATION

T-52-13-90

TSC426
TSC427
TSC428

TSC427

Electrical Characteristics: Over operating temperature range with $4.5\text{ V} \leq V_S \leq 18\text{ V}$ unless otherwise specified.

TYPE	NO.	SYMBOL	PARAMETER	CONDITIONS	TSC427			UNIT
					MIN	TYP	MAX	
INPUT	1	V_{IH}	Logic 1 Input Voltage		2.4	—	—	V
	2	V_{IL}	Logic 0 Input Voltage		—	—	0.8	V
	3	I_{IN}	Input Current	$0 \leq V_{IN} \leq V_S$	-10	—	10	μA
OUTPUT	4	V_{OH}	High Output Voltage		$V_S - 0.025$	—	—	V
	5	V_{OL}	Low Output Voltage		—	—	0.025	V
	6	R_O	Output Resistance	$V_{IN} = 2.4\text{ V}$ $I_{OUT} = 10\text{ mA}$, $V_S = 18\text{ V}$	—	13	20	Ω
	7	R_O	Output Resistance	$V_{IN} = 0.8\text{ V}$ $I_{OUT} = 10\text{ mA}$, $V_S = 18\text{ V}$	—	8	15	Ω
SWITCHING	8	T_R	Rise Time	Test Figure 1	—	—	60	ns
	9	T_F	Fall Time	Test Figure 1	—	—	40	ns
	10	T_{D1}	Delay Time	Test Figure 1	—	—	60	ns
	11	T_{D2}	Delay Time	Test Figure 1	—	—	120	ns
POWER SUPPLY	12	I_S	Power Supply Current	$V_{IN} = 3.0\text{ V}$ (Both Inputs)	—	—	12.0	mA
	13	I_S	Power Supply Current	$V_{IN} = 0.0\text{ V}$ (Both Inputs)	—	—	0.6	mA

11

TSC428

Electrical Characteristics: $T_A = 25^\circ\text{ C}$ with $4.5\text{ V} \leq V_S \leq 18\text{ V}$ unless otherwise specified.

TYPE	NO.	SYMBOL	PARAMETER	CONDITIONS	TSC428			UNIT
					MIN	TYP	MAX	
INPUT	1	V_{IH}	Logic 1 Input Voltage		2.4	—	—	V
	2	V_{IL}	Logic 0 Input Voltage		—	—	0.8	V
	3	I_{IN}	Input Current	$0 \leq V_{IN} \leq V_S$	-1	—	1	μA
OUTPUT	4	V_{OH}	High Output Voltage		$V_S - 0.025$	—	—	V
	5	V_{OL}	Low Output Voltage		—	—	0.025	V
	6	R_O	Output Resistance	Output High $I_{OUT} = 10\text{ mA}$, $V_S = 18\text{ V}$	—	10	15	Ω
	7	R_O	Output Resistance	Output Low $I_{OUT} = 10\text{ mA}$, $V_S = 18\text{ V}$	—	6	10	Ω
	8	I_{PK}	Peak Output Current		—	1.5	—	A

NOTES:

- Functional operation above the absolute maximum stress ratings is not implied.
- Static Sensitive device. Unused devices must be stored in conductive material to protect devices from static discharge and static fields.
- Switching times guaranteed by design.

TSC426

TSC427

TSC428

DUAL POWER MOSFET DRIVER

T-52-13-90

TSC428

Electrical Characteristics: $T_A = 25^\circ\text{C}$ with $4.5\text{ V} \leq V_S \leq 18\text{ V}$ unless otherwise specified.

TYPE	NO.	SYMBOL	PARAMETER	CONDITIONS	TSC428			UNIT
					MIN	TYP	MAX	
SWITCHING	9	T_R	Rise Time	Test Figure 1	—	—	30	ns
	10	T_F	Fall Time	Test Figure 1	—	—	20	ns
	11	T_{D1}	Delay Time	Test Figure 1	—	—	40	ns
	12	T_{D2}	Delay Time	Test Figure 1	—	—	75	ns
POWER SUPPLY	13	I_S	Power Supply Current	$V_{IN} = 3.0\text{ V}$ (Both Inputs)	—	—	8.0	mA
	14	I_S	Power Supply Current	$V_{IN} = 0.0\text{ V}$ (Both Inputs)	—	—	0.4	mA

TSC428

Electrical Characteristics: Over operating temperature range with $4.5\text{ V} \leq V_S \leq 18\text{ V}$ unless otherwise specified.

TYPE	NO.	SYMBOL	PARAMETER	CONDITIONS	TSC428			UNIT
					MIN	TYP	MAX	
INPUT	1	V_{IH}	Logic 1 Input Voltage		2.4	—	—	V
	2	V_{IL}	Logic 0 Input Voltage		—	—	0.8	V
	3	I_{IN}	Input Current	$0 \leq V_{IN} \leq V_S$	-10	—	10	μA
OUTPUT	4	V_{OH}	High Output Voltage		$V_S - 0.025$	—	—	V
	5	V_{OL}	Low Output Voltage		—	—	0.025	V
	6	R_O	Output Resistance	Output High $I_{OUT} = 10\text{ mA}$, $V_S = 18\text{ V}$	—	13	20	Ω
	7	R_O	Output Resistance	Output Low $I_{OUT} = 10\text{ mA}$, $V_S = 18\text{ V}$	—	8	15	Ω
SWITCHING	8	T_R	Rise Time	Test Figure 1	—	—	60	ns
	9	T_F	Fall Time	Test Figure 1	—	—	40	ns
	10	T_{D1}	Delay Time	Test Figure 1	—	—	60	ns
	11	T_{D2}	Delay Time	Test Figure 1	—	—	120	ns
POWER SUPPLY	12	I_S	Power Supply Current	$V_{IN} = 3.0\text{ V}$ (Both Inputs)	—	—	12.0	mA
	13	I_S	Power Supply Current	$V_{IN} = 0.0\text{ V}$ (Both Inputs)	—	—	0.6	mA

NOTES:

1. Functional operation above the absolute maximum stress ratings is not implied.

2. Static Sensitive device. Unused devices must be stored in conductive material to protect devices from static discharge and static fields.

3. Switching times guaranteed by design.

T-52-13-90

TSC426
TSC427
TSC428

Switching Time Test Circuits

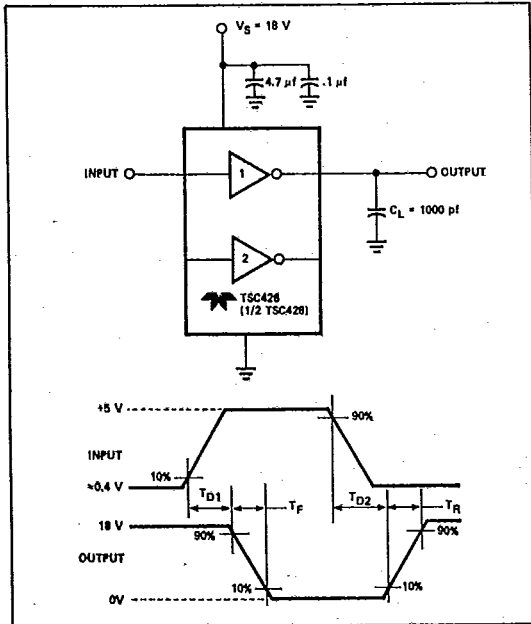

Figure 1: Inverting Driver Switching Time

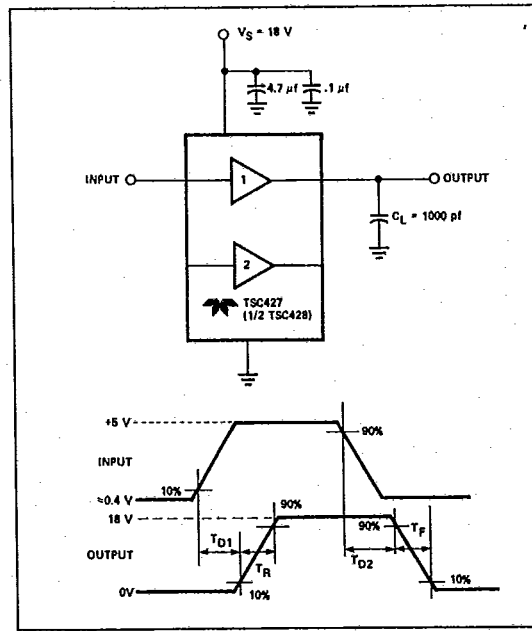
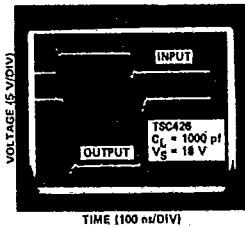
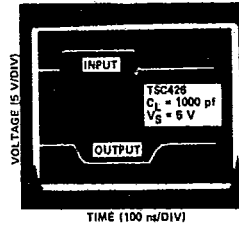

Figure 2: Non-Inverting Driver Switching Time

11



TSC426 Switching Speed



TSC426
TSC427
TSC428

DUAL POWER MOSFET DRIVER

T-52-13-90

Typical Characteristic Curves

Rise and Fall Time vs Supply Voltage

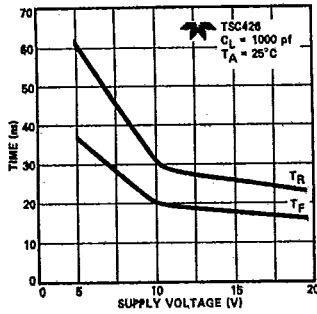

Delay Time vs Supply Voltage

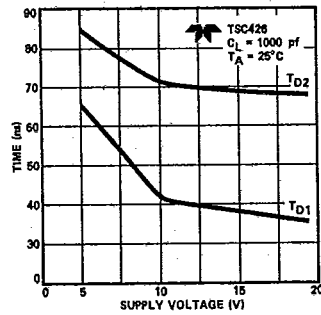

Rise and Fall Time vs Temperature

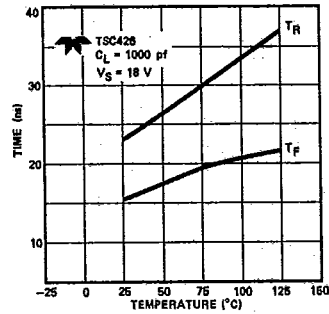

Delay Time vs Temperature

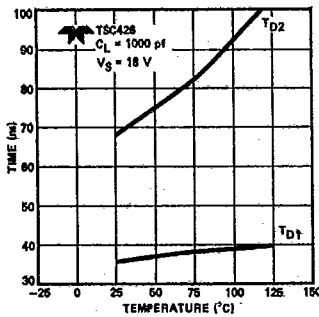

Supply Current vs Capacitive Load

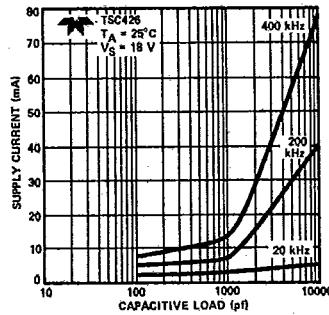

Rise and Fall Time vs Capacitive Load

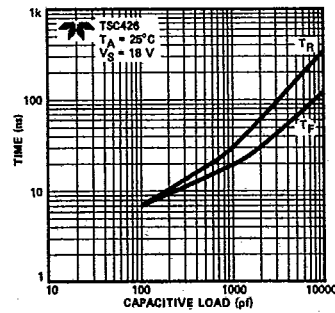

Supply Current vs Frequency

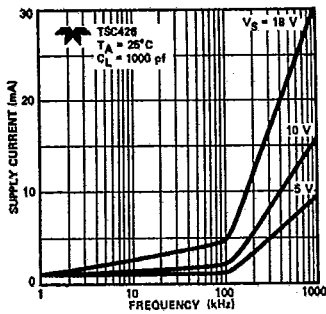

High Output vs Voltage

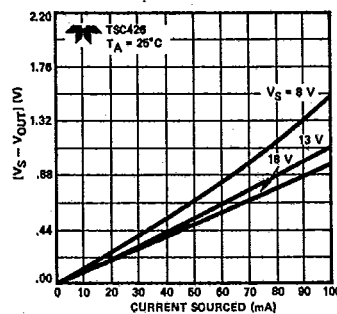

Low Output Voltage

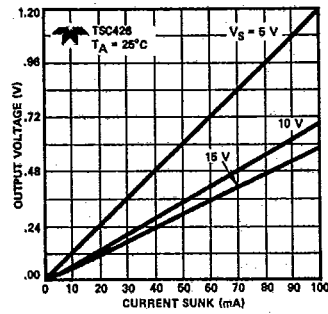

T-52-13-90

TSC426
TSC427
TSC428

Typical Characteristic Curves

Rise and Fall Time vs Temperature

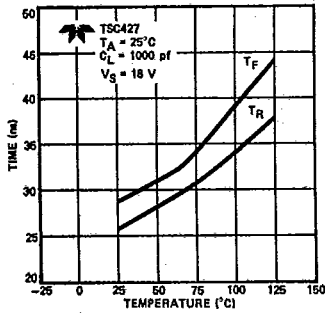

Delay Time vs Temperature

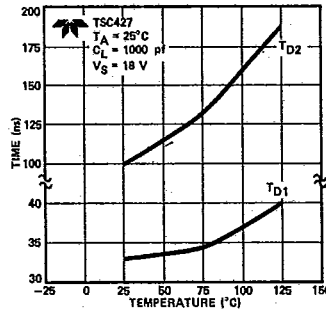

Rise and Fall Time vs Supply Voltage

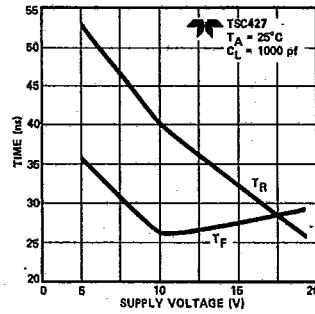

Delay Time vs Supply Voltage

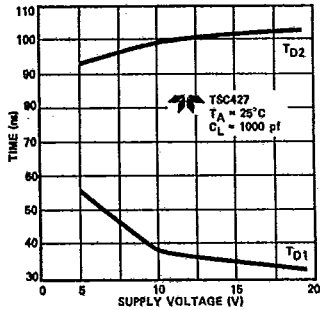

Supply Current vs Capacitive Load

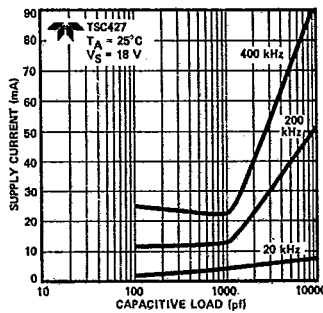

Rise and Fall Time vs Capacitive Load

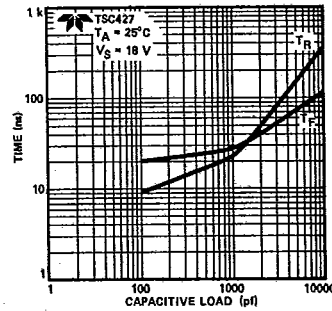

Supply Current vs Frequency

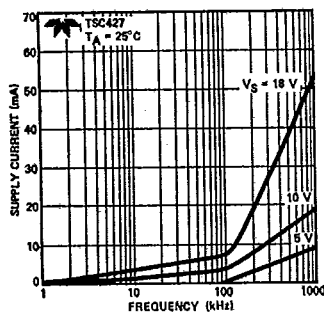

High Output Voltage

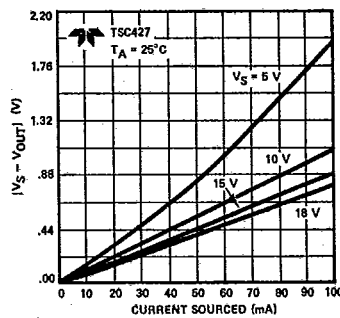

Low Output Voltage

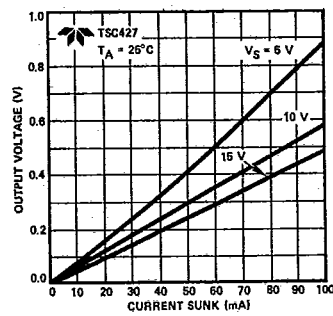

TSC426

TSC427

TSC428

DUAL POWER MOSFET DRIVER

T-52-13 -90

Typical Characteristic Curves

Quiescent Power Supply Current

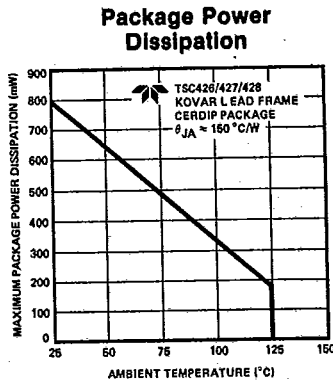
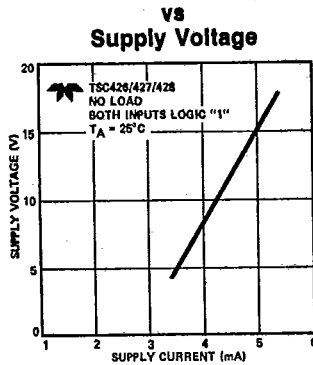

Quiescent Power Supply Current

vs
Supply Voltage

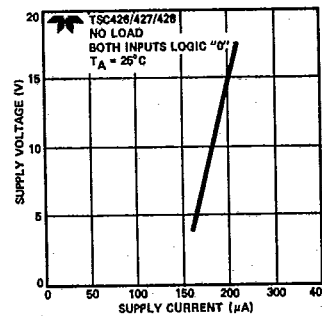

Supply Bypassing

Charging and discharging large capacitive loads quickly requires large currents. For example, changing a 1000 pf load 18 volts in 25 ns requires a 0.8 A current from the device power supply.

To guarantee low supply impedance over a wide frequency range, a parallel capacitor combination is recommended for supply bypassing. Low inductance ceramic disk capacitors with short lead lengths (<0.5 inch) should be used. A 4.7 µf solid tantalum capacitor in parallel with one or two 0.1 uf ceramic disk capacitors normally provides adequate bypassing.

Grounding

The TSC426 and TSC428 contain inverting drivers. Ground potential drops developed in common ground impedances from input to output will appear as negative feedback and degrade switching speed characteristics.

Individual ground returns for the input and output circuits or a ground plane should be used.

Input Stage

The input voltage level changes the no load or quiescent supply current. The N channel MOSFET input stage transistor drives a 2.5 mA current source load. With a logic "1" input, the maximum quiescent supply current is 8 mA. Logic "0" input level signals reduce quiescent current to 400 µA maximum. Minimum power dissipation occurs for logic "0" inputs for the TSC426/427/428; unused driver inputs **must be grounded or tied to the positive supply**.

The drivers are designed with 100 mV of hysteresis. This provides clean transitions and minimizes output stage current spiking when changing states. Input voltage thresholds are approximately 1.5 V making the device TTL compatible over the 4.5 V to 18 V operating supply range. Input current is less than 1 µA over this range.

The TSC426/427/428 may be directly driven by the TL494, SG1526/1527, SG1524, SE5560 and similar switch mode power supply integrated circuits.

Power Dissipation

The supply current vs frequency and supply current vs capacitive load characteristic curves will aid in determining power dissipation calculations.

The TSC426/427/428 CMOS drivers have greatly reduced quiescent DC power consumption. Maximum quiescent current is 8 mA compared to the DS0026 40 mA specification. For a 15 V supply, power dissipation is typically 40 mW.

Two other power dissipation components are:

- Output stage AC and DC load power.
- Transition state power.

Output stage power is:

$$P_o = P_{DC} + P_{AC}$$

$$= V_o (I_{DC}) + f C_L V_s^2$$

Where:

- V_o = DC output voltage
- I_{DC} = DC output load current
- f = Switching frequency
- V_s = Supply voltage

In power MOSFET drive applications the P_{DC} term is negligible. MOSFET power transistors are high impedance, capacitive input devices. In applications where resistive loads or relays are driven the P_{DC} component will normally dominate.

The magnitude of P_{AC} is readily estimated for several cases:

- | | | | |
|----|-----------------------------|----|-----------------------------|
| A. | 1. f = 200 kHz | B. | 1. f = 200 kHz |
| | 2. C _L = 1000 pf | | 2. C _L = 1000 pf |
| | 3. V _s = 18 V | | 3. V _s = 15 V |
| | 4. P _{AC} = 65 mW | | 4. P _{AC} = 45 mW |

PRODUCT INFORMATION

T-52-13-90 **TSC426**
TSC427
TSC428

During output level state changes, a current surge will flow through the series connected N and P channel output MOSFETS as one device is turning "ON" while the other is turning "OFF." The current spike flows only during output transitions. The input levels should not be maintained

between the logic "0" and logic "1" levels. **Unused driver inputs must be tied to ground and not be allowed to float.** Average power dissipation will be reduced by minimizing input rise times. As shown in the characteristic curves, average supply current is frequency dependent.

Voltage Doubler

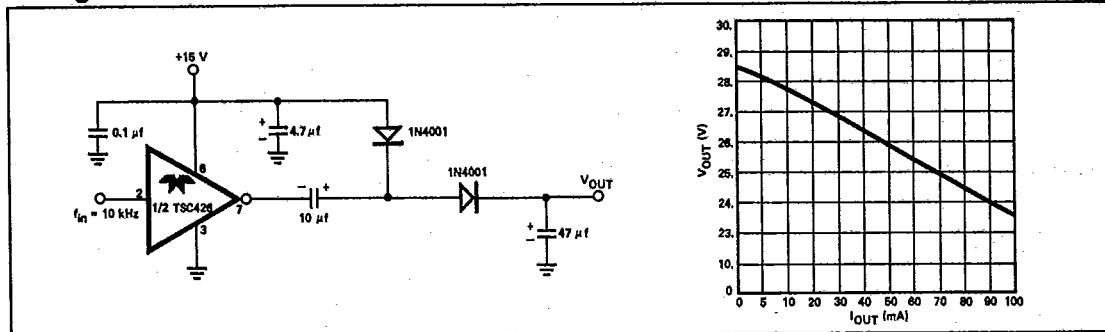

Voltage Inverter

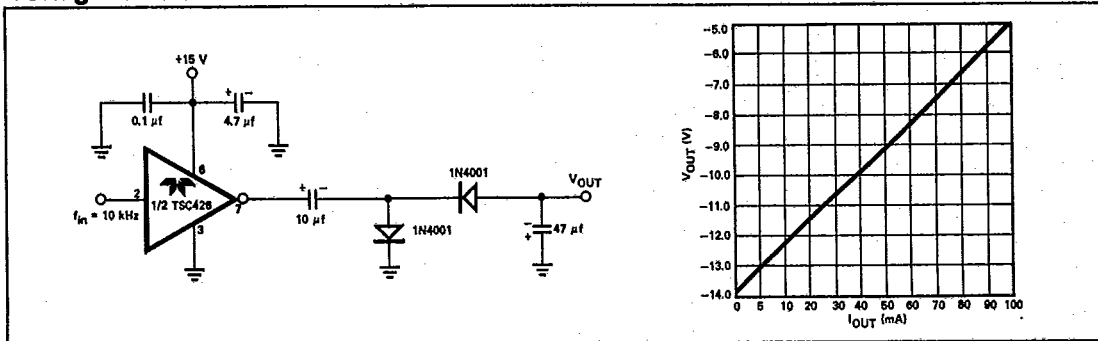

11

Package Information

