

To our customers,

Old Company Name in Catalogs and Other Documents

On April 1st, 2010, NEC Electronics Corporation merged with Renesas Technology Corporation, and Renesas Electronics Corporation took over all the business of both companies. Therefore, although the old company name remains in this document, it is a valid Renesas Electronics document. We appreciate your understanding.

Renesas Electronics website: <http://www.renesas.com>

April 1st, 2010
Renesas Electronics Corporation

Issued by: Renesas Electronics Corporation (<http://www.renesas.com>)

Send any inquiries to <http://www.renesas.com/inquiry>.

Notice

1. All information included in this document is current as of the date this document is issued. Such information, however, is subject to change without any prior notice. Before purchasing or using any Renesas Electronics products listed herein, please confirm the latest product information with a Renesas Electronics sales office. Also, please pay regular and careful attention to additional and different information to be disclosed by Renesas Electronics such as that disclosed through our website.
2. Renesas Electronics does not assume any liability for infringement of patents, copyrights, or other intellectual property rights of third parties by or arising from the use of Renesas Electronics products or technical information described in this document. No license, express, implied or otherwise, is granted hereby under any patents, copyrights or other intellectual property rights of Renesas Electronics or others.
3. You should not alter, modify, copy, or otherwise misappropriate any Renesas Electronics product, whether in whole or in part.
4. Descriptions of circuits, software and other related information in this document are provided only to illustrate the operation of semiconductor products and application examples. You are fully responsible for the incorporation of these circuits, software, and information in the design of your equipment. Renesas Electronics assumes no responsibility for any losses incurred by you or third parties arising from the use of these circuits, software, or information.
5. When exporting the products or technology described in this document, you should comply with the applicable export control laws and regulations and follow the procedures required by such laws and regulations. You should not use Renesas Electronics products or the technology described in this document for any purpose relating to military applications or use by the military, including but not limited to the development of weapons of mass destruction. Renesas Electronics products and technology may not be used for or incorporated into any products or systems whose manufacture, use, or sale is prohibited under any applicable domestic or foreign laws or regulations.
6. Renesas Electronics has used reasonable care in preparing the information included in this document, but Renesas Electronics does not warrant that such information is error free. Renesas Electronics assumes no liability whatsoever for any damages incurred by you resulting from errors in or omissions from the information included herein.
7. Renesas Electronics products are classified according to the following three quality grades: “Standard”, “High Quality”, and “Specific”. The recommended applications for each Renesas Electronics product depends on the product’s quality grade, as indicated below. You must check the quality grade of each Renesas Electronics product before using it in a particular application. You may not use any Renesas Electronics product for any application categorized as “Specific” without the prior written consent of Renesas Electronics. Further, you may not use any Renesas Electronics product for any application for which it is not intended without the prior written consent of Renesas Electronics. Renesas Electronics shall not be in any way liable for any damages or losses incurred by you or third parties arising from the use of any Renesas Electronics product for an application categorized as “Specific” or for which the product is not intended where you have failed to obtain the prior written consent of Renesas Electronics. The quality grade of each Renesas Electronics product is “Standard” unless otherwise expressly specified in a Renesas Electronics data sheets or data books, etc.
 - “Standard”: Computers; office equipment; communications equipment; test and measurement equipment; audio and visual equipment; home electronic appliances; machine tools; personal electronic equipment; and industrial robots.
 - “High Quality”: Transportation equipment (automobiles, trains, ships, etc.); traffic control systems; anti-disaster systems; anti-crime systems; safety equipment; and medical equipment not specifically designed for life support.
 - “Specific”: Aircraft; aerospace equipment; submersible repeaters; nuclear reactor control systems; medical equipment or systems for life support (e.g. artificial life support devices or systems), surgical implantations, or healthcare intervention (e.g. excision, etc.), and any other applications or purposes that pose a direct threat to human life.
8. You should use the Renesas Electronics products described in this document within the range specified by Renesas Electronics, especially with respect to the maximum rating, operating supply voltage range, movement power voltage range, heat radiation characteristics, installation and other product characteristics. Renesas Electronics shall have no liability for malfunctions or damages arising out of the use of Renesas Electronics products beyond such specified ranges.
9. Although Renesas Electronics endeavors to improve the quality and reliability of its products, semiconductor products have specific characteristics such as the occurrence of failure at a certain rate and malfunctions under certain use conditions. Further, Renesas Electronics products are not subject to radiation resistance design. Please be sure to implement safety measures to guard them against the possibility of physical injury, and injury or damage caused by fire in the event of the failure of a Renesas Electronics product, such as safety design for hardware and software including but not limited to redundancy, fire control and malfunction prevention, appropriate treatment for aging degradation or any other appropriate measures. Because the evaluation of microcomputer software alone is very difficult, please evaluate the safety of the final products or system manufactured by you.
10. Please contact a Renesas Electronics sales office for details as to environmental matters such as the environmental compatibility of each Renesas Electronics product. Please use Renesas Electronics products in compliance with all applicable laws and regulations that regulate the inclusion or use of controlled substances, including without limitation, the EU RoHS Directive. Renesas Electronics assumes no liability for damages or losses occurring as a result of your noncompliance with applicable laws and regulations.
11. This document may not be reproduced or duplicated, in any form, in whole or in part, without prior written consent of Renesas Electronics.
12. Please contact a Renesas Electronics sales office if you have any questions regarding the information contained in this document or Renesas Electronics products, or if you have any other inquiries.

(Note 1) “Renesas Electronics” as used in this document means Renesas Electronics Corporation and also includes its majority-owned subsidiaries.

(Note 2) “Renesas Electronics product(s)” means any product developed or manufactured by or for Renesas Electronics.

μ PD78054, 78054Y SUBSERIES

8-BIT SINGLE-CHIP MICROCONTROLLERS

μ PD78052	μ PD78052Y
μ PD78053	μ PD78053Y
μ PD78054	μ PD78054Y
μ PD78P054	μ PD78055Y
μ PD78055	μ PD78056Y
μ PD78056	μ PD78058Y
μ PD78058	μ PD78P058Y
μ PD78P058	
μ PD78052(A)	
μ PD78053(A)	
μ PD78054(A)	

[MEMO]

① PRECAUTION AGAINST ESD FOR SEMICONDUCTORS

Note:

Strong electric field, when exposed to a MOS device, can cause destruction of the gate oxide and ultimately degrade the device operation. Steps must be taken to stop generation of static electricity as much as possible, and quickly dissipate it once, when it has occurred. Environmental control must be adequate. When it is dry, humidifier should be used. It is recommended to avoid using insulators that easily build static electricity. Semiconductor devices must be stored and transported in an anti-static container, static shielding bag or conductive material. All test and measurement tools including work bench and floor should be grounded. The operator should be grounded using wrist strap. Semiconductor devices must not be touched with bare hands. Similar precautions need to be taken for PW boards with semiconductor devices on it.

② HANDLING OF UNUSED INPUT PINS FOR CMOS

Note:

No connection for CMOS device inputs can be cause of malfunction. If no connection is provided to the input pins, it is possible that an internal input level may be generated due to noise, etc., hence causing malfunction. CMOS devices behave differently than Bipolar or NMOS devices. Input levels of CMOS devices must be fixed high or low by using a pull-up or pull-down circuitry. Each unused pin should be connected to V_{DD} or GND with a resistor, if it is considered to have a possibility of being an output pin. All handling related to the unused pins must be judged device by device and related specifications governing the devices.

③ STATUS BEFORE INITIALIZATION OF MOS DEVICES

Note:

Power-on does not necessarily define initial status of MOS device. Production process of MOS does not define the initial operation status of the device. Immediately after the power source is turned ON, the devices with reset function have not yet been initialized. Hence, power-on does not guarantee out-pin levels, I/O settings or contents of registers. Device is not initialized until the reset signal is received. Reset operation must be executed immediately after power-on for devices having reset function.

FIP, EEPROM, IEBus, QTOP are trademarks of NEC Corporation.
MS-DOS, Windows, and Widows NT are either registered trademarks or trademarks of Microsoft Corporation in the United States and/or other countries.
IBM DOS, PC/AT and PC DOS are trademarks of International Business Machines Corporation.
HP9000 Series 700 and HP-UX are trademarks of Hewlett-Packard Company.
SPARCstation is a trademark of SPARC International, Inc.
Sun OS is a trademark of Sun Microsystems, Inc.
Ethernet is a trademark of XEROX Corporation.
NEWS and NEWS-OS are trademarks of SONY Corporation.
OSF/Motif is a trademark of Open Software Foundation, Inc.
TRON is an abbreviation of The Realtime Operating system Nucleus.
ITRON is an abbreviation of Industrial TRON.

The export of these products from Japan is regulated by the Japanese government. The export of some or all of these products may be prohibited without governmental license. To export or re-export some or all of these products from a country other than Japan may also be prohibited without a license from that country. Please call an NEC sales representative.

License not needed: μ PD78P054KK-T, 78P058KK-T, 78P058YKK-T

The customer must judge the need for license:

μ PD78052GC-xxx-8BT, 78052GK-xxx-BE9, 78052YGC-xxx-8BT
 μ PD78053GC-xxx-8BT, 78053GK-xxx-BE9, 78053YGC-xxx-8BT
 μ PD78054GC-xxx-8BT, 78054GK-xxx-BE9, 78054YGC-xxx-8BT
 μ PD78P054GC-3B9, 78P054GC-8BT, 78P054GK-BE9
 μ PD78055GC-xxx-8BT, 78055GK-xxx-BE9, 78055YGC-xxx-8BT
 μ PD78056GC-xxx-8BT, 78056GK-xxx-BE9, 78056YGC-xxx-8BT
 μ PD78058GC-xxx-8BT, 78058GK-xxx-BE9, 78058YGC-xxx-8BT
 μ PD78P058GC-8BT, 78P058YGC-8BT
 μ PD78052GC(A)-xxx-3B9, 78053GC(A)-xxx-3B9, 78054GC(A)-xxx-3B9

The application circuits and their parameters are for reference only and are not intended for use in actual design-ins.

Purchase of NEC I²C components conveys a license under the Philips I²C Patent Rights to use these components in an I²C system, provided that the system conforms to the I²C Standard Specification as defined by Philips.

The information in this document is subject to change without notice.

No part of this document may be copied or reproduced in any form or by any means without the prior written consent of NEC Corporation. NEC Corporation assumes no responsibility for any errors which may appear in this document.

NEC Corporation does not assume any liability for infringement of patents, copyrights or other intellectual property rights of third parties by or arising from use of a device described herein or any other liability arising from use of such device. No license, either express, implied or otherwise, is granted under any patents, copyrights or other intellectual property rights of NEC Corporation or others.

While NEC Corporation has been making continuous effort to enhance the reliability of its semiconductor devices, the possibility of defects cannot be eliminated entirely. To minimize risks of damage or injury to persons or property arising from a defect in an NEC semiconductor device, customers must incorporate sufficient safety measures in its design, such as redundancy, fire-containment, and anti-failure features.

NEC devices are classified into the following three quality grades:

“Standard”, “Special”, and “Specific”. The Specific quality grade applies only to devices developed based on a customer designated “quality assurance program” for a specific application. The recommended applications of a device depend on its quality grade, as indicated below. Customers must check the quality grade of each device before using it in a particular application.

Standard: Computers, office equipment, communications equipment, test and measurement equipment, audio and visual equipment, home electronic appliances, machine tools, personal electronic equipment and industrial robots

Special: Transportation equipment (automobiles, trains, ships, etc.), traffic control systems, anti-disaster systems, anti-crime systems, safety equipment and medical equipment (not specifically designed for life support)

Specific: Aircrafts, aerospace equipment, submersible repeaters, nuclear reactor control systems, life support systems or medical equipment for life support, etc.

The quality grade of NEC devices is “Standard” unless otherwise specified in NEC’s Data Sheets or Data Books. If customers intend to use NEC devices for applications other than those specified for Standard quality grade, they should contact an NEC sales representative in advance.

Anti-radioactive design is not implemented in this product.

M7 96.5

Regional Information

Some information contained in this document may vary from country to country. Before using any NEC product in your application, please contact the NEC office in your country to obtain a list of authorized representatives and distributors. They will verify:

- Device availability
- Ordering information
- Product release schedule
- Availability of related technical literature
- Development environment specifications (for example, specifications for third-party tools and components, host computers, power plugs, AC supply voltages, and so forth)
- Network requirements

In addition, trademarks, registered trademarks, export restrictions, and other legal issues may also vary from country to country.

NEC Electronics Inc. (U.S.)

Santa Clara, California
Tel: 408-588-6000
800-366-9782
Fax: 408-588-6130
800-729-9288

NEC Electronics (Germany) GmbH

Duesseldorf, Germany
Tel: 0211-65 03 02
Fax: 0211-65 03 490

NEC Electronics (UK) Ltd.

Milton Keynes, UK
Tel: 01908-691-133
Fax: 01908-670-290

NEC Electronics Italiana s.r.l.

Milano, Italy
Tel: 02-66 75 41
Fax: 02-66 75 42 99

NEC Electronics (Germany) GmbH

Benelux Office
Eindhoven, The Netherlands
Tel: 040-2445845
Fax: 040-2444580

NEC Electronics (France) S.A.

Velizy-Villacoublay, France
Tel: 01-30-67 58 00
Fax: 01-30-67 58 99

NEC Electronics (France) S.A.

Spain Office
Madrid, Spain
Tel: 01-504-2787
Fax: 01-504-2860

NEC Electronics (Germany) GmbH

Scandinavia Office
Taeby, Sweden
Tel: 08-63 80 820
Fax: 08-63 80 388

NEC Electronics Hong Kong Ltd.

Hong Kong
Tel: 2886-9318
Fax: 2886-9022/9044

NEC Electronics Hong Kong Ltd.

Seoul Branch
Seoul, Korea
Tel: 02-528-0303
Fax: 02-528-4411

NEC Electronics Singapore Pte. Ltd.

United Square, Singapore 1130
Tel: 65-253-8311
Fax: 65-250-3583

NEC Electronics Taiwan Ltd.

Taipei, Taiwan
Tel: 02-719-2377
Fax: 02-719-5951

NEC do Brasil S.A.

Cumbica-Guarulhos-SP, Brasil
Tel: 011-6465-6810
Fax: 011-6465-6829

Major Revisions in This Edition

Page	Description
Throughout	Addition of μ PD78052(A),78053(A), 78054(A) to the applicable types Deletion of μ PD78P054Y from the applicable types Deletion of the following package from the μ PD78052, 78053, 78054, 78055, 78056, 78058, 78P058, 78054Y Subseries: • 80-pin plastic QFP (14 × 14 mm, resin thickness 2.7 mm)
p. 233	Addition of Figure 9-10. Square-Wave Output Operation Timing
p. 238	Addition of Figure 9-13. Square-Wave Output Operation Timing
p. 296	Addition of Note to Figure 16-4. Serial Operating Mode Register 0 Format
p. 430, 435	Addition of (4) Synchronization control and (5) Automatic transmit/receive Interval time to 18.4.3 3-wire serial I/O mode operation with automatic transmit/receive function
p. 439	Addition of precaution to 19.1 (3) 3-wire serial I/O mode (MSB-/LSB-first switchable)
p. 444	Change of Figure 19-3. Serial Operating Mode Register 2 Format
p. 446	Change of Table 19-2. Serial Interface Channel 2 Operating Mode Settings
p. 465	Correction of Figure 19-10. Receive Error Timing
p. 474	Addition of 19.4.4 Limitations when UART mode is used
p. 577, 578	Addition of APPENDIX A DIFFERENCES BETWEEN μPD78054, 78054Y SUBSERIES AND μPD78058F, 78058FY SUBSERIES
p. 579 to 592	APPENDIX B DEVELOPMENT TOOL Entire revision: Support for in-circuit emulator IE-78K0-NS
p. 593, 594	APPENDIX C EMBEDDED SOFTWARE Entire revision: Deletion of fuzzy inference development support system

The mark ★ shows major revised points.

[MEMO]

PREFACE

Readers

This manual has been prepared for user engineers who want to understand the functions of the μ PD78054 and 78054Y Subseries and design and develop its application systems and programs.

The target products are the products of the following subseries.

- μ PD78054 Subseries : μ PD78052, 78053, 78054, 78P054, 78055, 78056, μ PD78058, 78P058, 78052(A), 78053(A), 78054(A)
- μ PD78054Y Subseries : μ PD78052Y, 78053Y, 78054Y, 78055Y, 78056Y, μ PD78058Y, 78P058Y

Caution

Of the above members, the following devices with the suffix KK-T should be used only for experiment or function evaluation, because they are not intended for use in equipment that will be mass-produced and require high reliability.

- μ PD78P054KK-T, 78P058KK-T, 78P058YKK-T

Purpose

This manual is intended for users to understand the functions described in the Organization below.

Organization

The μ PD78054, 78054Y Subseries manual is separated into two parts: this manual and the instruction edition (common to the 78K/0 Series).

μ PD78054, 78054Y Subseries User's Manual (This manual)
--

- Pin functions
- Internal block functions
- Interrupt
- Other on-chip peripheral functions

78K/0 Series User's Manual Instruction
--

- CPU functions
- Instruction set
- Explanation of each instruction

How to Read This Manual

Before reading this manual, you should have general knowledge of electric and logic circuits and microcontrollers.

- For users who use this document as the manual for the μ PD78052(A), 78053(A), and 78054(A):
 - The only differences between the μ PD78052, 78053, and 78054 and the μ PD78052(A), 78053(A), 78054(A) are the quality grades and packages. (refer to 1.9 Differences between Standard Quality Grade Products and (A) Products). For the (A) products, read the part numbers in the following manner.
 - μ PD78052 → μ PD78052(A)
 - μ PD78053 → μ PD78053(A)
 - μ PD78054 → μ PD78054(A)
- When you want to understand the functions in general:
 - Read this manual in the order of the contents.
- To know the μ PD78054 and 78054Y Subseries instruction function in detail:
 - Refer to the **78K/0 Series User's Manual: Instructions (U12326E)**
- How to interpret the register format:
 - For the circled bit number, the bit name is defined as a reserved word in RA78K/0, and in CC78K/0, already defined in the header file named **sfrbit.h**.
- To learn the function of a register whose register name is known:
 - Refer to **Appendix D Register Index**.
- To know the electrical specifications of the μ PD78054 and 78054Y Subseries:
 - Refer to separately available Data Sheet.
- To know application examples of the functions provided in the μ PD78054 and 78054Y Subseries:
 - Refer to Application Note separately provided.

Caution The application examples in this manual are created for “Standard” quality grade products for general electric equipment. When using the application examples in this manual for purposes which require “Special” quality grades, thoroughly examine the quality grade of each part and circuit actually used.

Chapter Organization: This manual divides the descriptions for the μ PD78054 and 78054Y Subseries into different chapters as shown below. Read only the chapters related to the device you use.

Chapter		μ PD78054	μ PD78054Y
		Subseries	Subseries
Chapter 1	Outline (μ PD78054 Subseries)	√	—
Chapter 2	Outline (μ PD78054Y Subseries)	—	√
Chapter 3	Pin Function (μ PD78054 Subseries)	√	—
Chapter 4	Pin Function (μ PD78054Y Subseries)	—	√
Chapter 5	CPU Architecture	√	√
Chapter 6	Port Functions	√	√
Chapter 7	Clock Generator	√	√
Chapter 8	16-Bit Timer/Event Counter	√	√
Chapter 9	8-Bit Timer/Event Counters 1 and 2	√	√
Chapter 10	Watch Timer	√	√
Chapter 11	Watchdog Timer	√	√
Chapter 12	Clock Output Control Circuit	√	√
Chapter 13	Buzzer Output Control Circuit	√	√
Chapter 14	A/D Converter	√	√
Chapter 15	D/A Converter	√	√
Chapter 16	Serial Interface Channel 0 (μ PD78054 Subseries)	√	—
Chapter 17	Serial Interface Channel 0 (μ PD78054Y Subseries)	—	√
Chapter 18	Serial Interface Channel 1	√	√
Chapter 19	Serial Interface Channel 2	√	√
Chapter 20	Real-Time Output Port	√	√
Chapter 21	Interrupt and Test Functions	√	√
Chapter 22	External Device Expansion Function	√	√
Chapter 23	Standby Function	√	√
Chapter 24	Reset Function	√	√
Chapter 25	ROM Correction	√	√
Chapter 26	μ PD78P054, μ PD78P058	√	√
Chapter 27	Instruction Set	√	√

Differences between μ PD78054 and μ PD78054Y Subseries:

The μ PD78054 and μ PD78054Y Subseries are different in the following functions of the serial interface channel 0.

Modes of serial interface channel 0	μ PD78054 Subseries	μ PD78054Y Subseries
3-wire serial I/O mode	√	√
2-wire serial I/O mode	√	√
SBI (serial bus interface) mode	√	—
I ² C (Inter IC) bus mode	—	√

√ : Supported

— : Not supported

Legend

Data significant	:	Left: higher digit, right: lower digit
Active low	:	$\overline{\text{xxx}}$ (top bar over pin or signal name)
Note	:	Footnote
Caution	:	Important information
Remark	:	Supplement
Numerical notation	:	Binary ... xxxx or xxxxB Decimal ... xxxx Hexadecimal ... xxxxH

Related Documents

The related documents indicated in this publication may include preliminary versions. However, preliminary versions are not marked as such.

● **Related documents for μ PD78054 Subseries**

Document name	Document No.		
	Japanese	English	
μ PD78052, 78053, 78054, 78055, 78056, 78058 Data Sheet	U12327J	U12327E	
μ PD78052(A), 78053(A), 78054(A) Data Sheet	U12171J	U12171E	
μ PD78P054, 78P058 Data Sheet	U10417J	U10417E	
μ PD78054, 78054Y Subseries User's Manual	U11747J	This manual	
78K/0 Series User's Manual, Instruction	U12326J	U12326E	
78K/0 Series Instruction Table	U10903J	—	
78K/0 Series Instruction Set	U10904J	—	
μ PD78054 Subseries Special Function Register Table	U10102J	—	
78K/0 Series Application Note	Basics (III)	U10182J	U10182E
	Floating-point operation program	IEA-718	IEA-1289

● **Related documents for μ PD78054Y Subseries**

Document name	Document No.		
	Japanese	English	
μ PD78052Y, 78053Y, 78054Y, 78055Y, 78056Y, 78058Y Data Sheet	U10906J	U10906E	
μ PD78P058Y Data Sheet	U10907J	U10907E	
μ PD78054, 78054Y Subseries User's Manual	U11747J	This manual	
78K/0 Series User's Manual, Instruction	U12326J	U12326E	
78K/0 Series Instruction Table	U10903J	—	
78K/0 Series Instruction Set	U10904J	—	
μ PD78054Y Subseries Special Function Register Table	U10087J	—	
78K/0 Series Application Note	Basics (III)	U10182J	U10182E

Caution The above documents are subject to change without prior notice. Be sure to use the latest version document when starting design.

● Development Tool Documents (User's Manuals)

Document name		Document No.	
		Japanese	English
RA78K0 Assembler Package	Operation	U11802J	U11802E
	Assembly Language	U11801J	U11801E
	Structured Assembly	U11789J	U11789E
RA78K Series Structured Assembler Preprocessor		U12323J	EEU-1402
CC78K0 C Compiler	Operation	U11517J	U11517E
	Language	U11518J	U11518E
CC78K0 C Compiler Application Note	Programming know-how	U13034J	EEA-1208
CC78K Series Library Source File		U12322J	—
PG-1500 PROM Programmer		U11940J	U11940E
PG-1500 Controller PC-9800 Series (MS-DOS™) Base		EEU-704	EEU-1291
PG-1500 Controller IBM PC Series (PC DOS™) Base		EEU-5008	U10540E
IE-78K0-NS		To be prepared	To be prepared
IE-78001-R-A		To be prepared	To be prepared
IE-780308-NS-EM1		To be prepared	To be prepared
IE-780308-R-EM		U11362J	U11362E
EP-78230		EEU-985	EEU-1515
EP-78054GK-R		EEU-932	EEU-1468
SM78K0 System Simulator Windows™ Base	Reference	U10181J	U10181E
SM78K Series System Simulator	External component user open interface specifications	U10092J	U10092E
ID78K0-NS Integrated Debugger	Reference	U12900J	To be prepared
ID78K0 Integrated Debugger EWS Base	Reference	U11151J	—
ID78K0 Integrated Debugger PC Base	Reference	U11539J	U11539E
ID78K0 Integrated Debugger Windows Base	Guide	U11649J	U11649E

Caution The above documents are subject to change without prior notice. Be sure to use the latest version document when starting design.

● Documents for Embedded Software (User's Manual)

Document name		Document No.	
		Japanese	English
78K/0 Series Real-Time OS	Basics	U11537J	U11537E
	Installation	U11536J	U11536E
OS for 78K/0 Series MX78K0	Basics	U12257J	U12257E

● Other Documents

Document name		Document No.	
		Japanese	English
IC PACKAGE MANUAL		C10943X	
Semiconductor Device Mounting Technology Manual		C10535J	C10535E
Quality Grade on NEC Semiconductor Devices		C11531J	C11531E
NEC Semiconductor Device Reliability/Quality Control System		C10983J	C10983E
Guide to Prevent Damage for Semiconductor Devices by Electrostatic Discharge (ESD)		C11892J	C11892E
Guide to Quality Assurance for Semiconductor Devices		—	MEI-1202
Microcontroller Related Product Guide—Third Party Manufacturers		U11416J	—

Caution The above documents are subject to change without prior notice. Be sure to use the latest version document when starting design.

[MEMO]

TABLE OF CONTENTS

CHAPTER 1 GENERAL (μPD78054 Subseries)	37
1.1 Features	37
1.2 Applications	38
1.3 Ordering Information	38
1.4 Quality Grade	39
1.5 Pin Configuration (Top View)	40
1.6 78K/0 Series Expansion	43
1.7 Block Diagram	45
1.8 Outline of Function	46
1.9 Differences between Standard Quality Grade Products and (A) Products	48
1.10 Mask Options	48
CHAPTER 2 GENERAL (μPD78054Y Subseries)	49
2.1 Features	49
2.2 Applications	50
2.3 Ordering Information	50
2.4 Quality Grade	50
2.5 Pin Configuration (Top View)	51
2.6 78K/0 Series Expansion	54
2.7 Block Diagram	56
2.8 Outline of Function	57
2.9 Mask Options	58
CHAPTER 3 PIN FUNCTION (μPD78054 Subseries)	59
3.1 Pin Function List	59
3.1.1 Normal operating mode pins	59
3.1.2 PROM programming mode pins (PROM versions only)	63
3.2 Description of Pin Functions	64
3.2.1 P00 to P07 (Port 0)	64
3.2.2 P10 to P17 (Port 1)	65
3.2.3 P20 to P27 (Port 2)	65
3.2.4 P30 to P37 (Port 3)	66
3.2.5 P40 to P47 (Port 4)	67
3.2.6 P50 to P57 (Port 5)	67
3.2.7 P60 to P67 (Port 6)	67
3.2.8 P70 to P72 (Port 7)	68
3.2.9 P120 to P127 (Port 12)	69
3.2.10 P130 and P131 (Port 13)	69
3.2.11 AVREF0	69
3.2.12 AVREF1	69
3.2.13 AVDD	70
3.2.14 AVSS	70
3.2.15 RESET	70
3.2.16 X1 and X2	70
3.2.17 XT1 and XT2	70

3.2.18	V _{DD}	70
3.2.19	V _{SS}	70
3.2.20	V _{PP} (PROM versions only)	70
3.2.21	IC (Mask ROM version only)	70
3.3	Input/output Circuits and Recommended Connection of Unused Pins	71
CHAPTER 4 PIN FUNCTION (μPD78054Y Subseries)		75
4.1	Pin Function List	75
4.1.1	Normal operating mode pins	75
4.1.2	PROM programming mode pins (PROM versions only)	79
4.2	Description of Pin Functions	80
4.2.1	P00 to P07 (Port 0)	80
4.2.2	P10 to P17 (Port 1)	81
4.2.3	P20 to P27 (Port 2)	81
4.2.4	P30 to P37 (Port 3)	82
4.2.5	P40 to P47 (Port 4)	82
4.2.6	P50 to P57 (Port 5)	83
4.2.7	P60 to P67 (Port 6)	83
4.2.8	P70 to P72 (Port 7)	84
4.2.9	P120 to P127 (Port 12)	84
4.2.10	P130 and P131 (Port 13)	85
4.2.11	AV _{REF0}	85
4.2.12	AV _{REF1}	85
4.2.13	AV _{DD}	85
4.2.14	AV _{SS}	85
4.2.15	RESET	85
4.2.16	X1 and X2	86
4.2.17	XT1 and XT2	86
4.2.18	V _{DD}	86
4.2.19	V _{SS}	86
4.2.20	V _{PP} (PROM versions only)	86
4.2.21	IC (Mask ROM version only)	86
4.3	Input/output Circuits and Recommended Connection of Unused Pins	87
CHAPTER 5 CPU ARCHITECTURE		91
5.1	Memory Spaces	91
5.1.1	Internal program memory space	99
5.1.2	Internal data memory space	100
5.1.3	Special Function Register (SFR) area	100
5.1.4	External memory space	100
5.1.5	Data memory addressing	101
5.2	Processor Registers	109
5.2.1	Control registers	109
5.2.2	General registers	112
5.2.3	Special Function Register (SFR)	114
5.3	Instruction Address Addressing	118
5.3.1	Relative addressing	118
5.3.2	Immediate addressing	119

5.3.3	Table indirect addressing	120
5.3.4	Register addressing	120
5.4	Operand Address Addressing	121
5.4.1	Implied addressing	121
5.4.2	Register addressing	122
5.4.3	Direct addressing	123
5.4.4	Short direct addressing	124
5.4.5	Special-Function Register (SFR) addressing	125
5.4.6	Register indirect addressing	126
5.4.7	Based addressing	127
5.4.8	Based indexed addressing	128
5.4.9	Stack addressing	128
CHAPTER 6	PORT FUNCTIONS	129
6.1	Port Functions	129
6.2	Port Configuration	134
6.2.1	Port 0	134
6.2.2	Port 1	136
6.2.3	Port 2 (μ PD78054 Subseries)	137
6.2.4	Port 2 (μ PD78054Y Subseries)	139
6.2.5	Port 3	141
6.2.6	Port 4	142
6.2.7	Port 5	143
6.2.8	Port 6	144
6.2.9	Port 7	146
6.2.10	Port 12	148
6.2.11	Port 13	149
6.3	Port Function Control Registers	150
6.4	Port Function Operations	156
6.4.1	Writing to input/output port	156
6.4.2	Reading from input/output port	156
6.4.3	Operations on input/output port	157
6.5	Selection of Mask Option	157
CHAPTER 7	CLOCK GENERATOR	159
7.1	Clock Generator Functions	159
7.2	Clock Generator Configuration	159
7.3	Clock Generator Control Register	161
7.4	System Clock Oscillator	165
7.4.1	Main system clock oscillator	165
7.4.2	Subsystem clock oscillator	166
7.4.3	Scaler	168
7.4.4	When no subsystem clocks are used	168
7.5	Clock Generator Operations	169
7.5.1	Main system clock operations	170
7.5.2	Subsystem clock operations	171
7.6	Changing System Clock and CPU Clock Settings	171
7.6.1	Time required for switchover between system clock and CPU clock	171
7.6.2	System clock and CPU clock switching procedure	173

CHAPTER 8	16-BIT TIMER/EVENT COUNTER	175
8.1	Outline of Timers Incorporated in the μ PD78054, 78054Y Subseries	175
8.2	16-Bit Timer/Event Counter Functions	177
8.3	16-Bit Timer/Event Counter Configuration	179
8.4	16-Bit Timer/Event Counter Control Registers	182
8.5	16-Bit Timer/Event Counter Operations	191
8.5.1	Interval timer operations	191
8.5.2	PWM output operations	193
8.5.3	PPG output operations	196
8.5.4	Pulse width measurement operations	197
8.5.5	External event counter operation	204
8.5.6	Square-wave output operation	206
8.5.7	One-shot pulse output operation	208
8.6	16-Bit Timer/Event Counter Operating Precautions	212
CHAPTER 9	8-BIT TIMER/EVENT COUNTERS 1 AND 2	215
9.1	8-Bit Timer/Event Counters 1 and 2 Functions	215
9.1.1	8-bit timer/event counter mode	215
9.1.2	16-bit timer/event counter mode	218
9.2	8-Bit Timer/Event Counters 1 and 2 Configurations	220
9.3	8-Bit Timer/Event Counters 1 and 2 Control Registers	223
9.4	8-Bit Timer/Event Counters 1 and 2 Operations	228
9.4.1	8-bit timer/event counter mode	228
9.4.2	16-bit timer/event counter mode	234
9.5	Cautions on 8-Bit Timer/Event Counters 1 and 2	238
CHAPTER 10	WATCH TIMER	241
10.1	Watch Timer Functions	241
10.2	Watch Timer Configuration	242
10.3	Watch Timer Control Registers	242
10.4	Watch Timer Operations	246
10.4.1	Watch timer operation	246
10.4.2	Interval timer operation	246
CHAPTER 11	WATCHDOG TIMER	247
11.1	Watchdog Timer Functions	247
11.2	Watchdog Timer Configuration	249
11.3	Watchdog Timer Control Registers	250
11.4	Watchdog Timer Operations	253
11.4.1	Watchdog timer operation	253
11.4.2	Interval timer operation	254
CHAPTER 12	CLOCK OUTPUT CONTROL CIRCUIT	255
12.1	Clock Output Control Circuit Functions	255
12.2	Clock Output Control Circuit Configuration	256
12.3	Clock Output Function Control Registers	257

CHAPTER 13 BUZZER OUTPUT CONTROL CIRCUIT	261
13.1 Buzzer Output Control Circuit Functions	261
13.2 Buzzer Output Control Circuit Configuration	261
13.3 Buzzer Output Function Control Registers	262
CHAPTER 14 A/D CONVERTER	265
14.1 A/D Converter Functions	265
14.2 A/D Converter Configuration	265
14.3 A/D Converter Control Registers	269
14.4 A/D Converter Operations	273
14.4.1 Basic operations of A/D converter	273
14.4.2 Input voltage and conversion results	275
14.4.3 A/D converter operating mode	276
14.5 A/D Converter Cautions	278
CHAPTER 15 D/A CONVERTER	281
15.1 D/A Converter Functions	281
15.2 D/A Converter Configuration	282
15.3 D/A Converter Control Registers	284
15.4 Operations of D/A Converter	285
15.5 Cautions Related to D/A Converter	286
CHAPTER 16 SERIAL INTERFACE CHANNEL 0 (μPD78054 Subseries)	287
16.1 Serial Interface Channel 0 Functions	288
16.2 Serial Interface Channel 0 Configuration	290
16.3 Serial Interface Channel 0 Control Registers	294
16.4 Serial Interface Channel 0 Operations	301
16.4.1 Operation stop mode	301
16.4.2 3-wire serial I/O mode operation	302
16.4.3 SBI mode operation	307
16.4.4 2-wire serial I/O mode operation	333
16.4.5 $\overline{\text{SCK0}}$ /P27 pin output manipulation	339
CHAPTER 17 SERIAL INTERFACE CHANNEL 0 (μPD78054Y Subseries)	341
17.1 Serial Interface Channel 0 Functions	342
17.2 Serial Interface Channel 0 Configuration	344
17.3 Serial Interface Channel 0 Control Registers	348
17.4 Serial Interface Channel 0 Operations	356
17.4.1 Operation stop mode	356
17.4.2 3-wire serial I/O mode operation	357
17.4.3 2-wire serial I/O mode operation	361
17.4.4 I ² C bus mode operation	367
17.4.5 Cautions on use of I ² C bus mode	385
17.4.6 Restrictions in I ² C bus mode	388
17.4.7 $\overline{\text{SCK0}}$ /SCL/P27 pin output manipulation	390

CHAPTER 18 SERIAL INTERFACE CHANNEL 1	393
18.1 Serial Interface Channel 1 Functions	393
18.2 Serial Interface Channel 1 Configuration	394
18.3 Serial Interface Channel 1 Control Registers	397
18.4 Serial Interface Channel 1 Operations	405
18.4.1 Operation stop mode	405
18.4.2 3-wire serial I/O mode operation	406
18.4.3 3-wire serial I/O mode operation with automatic transmit/receive function	409
CHAPTER 19 SERIAL INTERFACE CHANNEL 2	439
19.1 Serial Interface Channel 2 Functions	439
19.2 Serial Interface Channel 2 Configuration	440
19.3 Serial Interface Channel 2 Control Registers	444
19.4 Serial Interface Channel 2 Operation	452
19.4.1 Operation stop mode	452
19.4.2 Asynchronous serial interface (UART) mode	454
19.4.3 3-wire serial I/O mode	467
19.4.4 Limitations when UART mode is used	474
CHAPTER 20 REAL-TIME OUTPUT PORT	477
20.1 Real-Time Output Port Functions	477
20.2 Real-Time Output Port Configuration	478
20.3 Real-Time Output Port Control Registers	480
CHAPTER 21 INTERRUPT AND TEST FUNCTIONS	483
21.1 Interrupt Function Types	483
21.2 Interrupt Sources and Configuration	484
21.3 Interrupt Function Control Registers	488
21.4 Interrupt Servicing Operations	497
21.4.1 Non-maskable interrupt request acknowledge operation	497
21.4.2 Maskable interrupt request acknowledge operation	500
21.4.3 Software interrupt request acknowledge operation	503
21.4.4 Multiple interrupt servicing	503
21.4.5 Interrupt request reserve	506
21.5 Test Functions	507
21.5.1 Registers controlling the test function	507
21.5.2 Test input signal acknowledge operation	509
CHAPTER 22 EXTERNAL DEVICE EXPANSION FUNCTION	511
22.1 External Device Expansion Functions	511
22.2 External Device Expansion Function Control Register	516
22.3 External Device Expansion Function Timing	518
22.4 Example of Connection with Memory	523
CHAPTER 23 STANDBY FUNCTION	525
23.1 Standby Function and Configuration	525
23.1.1 Standby function	525
23.1.2 Standby function control register	526

23.2 Standby Function Operations	527
23.2.1 HALT mode	527
23.2.2 STOP mode	530
CHAPTER 24 RESET FUNCTION	533
24.1 Reset Function	533
CHAPTER 25 ROM CORRECTION	537
25.1 ROM Correction Functions	537
25.2 ROM Correction Configuration	537
25.3 ROM Correction Control Registers	539
25.4 ROM Correction Application	540
25.5 ROM Correction Example	543
25.6 Program Execution Flow	544
25.7 Cautions on ROM Correction	546
CHAPTER 26 μPD78P054, 78P058	547
26.1 Memory Size Switching Register (μPD78P054)	549
26.2 Memory Size Switching Register (μPD78P058)	550
26.3 Internal Expansion RAM Size Switching Register	551
26.4 PROM Programming	552
26.4.1 Operating modes	552
26.4.2 PROM write procedure	554
26.4.3 PROM reading procedure	558
26.5 Erasure Procedure (μPD78P054KK-T and 78P058KK-T Only)	559
26.6 Opaque Film Masking the Window (μPD78P054KK-T and 78P058KK-T Only)	559
26.7 Screening of One-Time PROM Versions	559
CHAPTER 27 INSTRUCTION SET	561
27.1 Legends Used in Operation List	562
27.1.1 Operand identifiers and description methods	562
27.1.2 Description of "operation" column	563
27.1.3 Description of "flag operation" column	563
27.2 Operation List	564
27.3 Instructions Listed by Addressing Type	572
APPENDIX A DIFFERENCES BETWEEN μPD78054, 78054Y SUBSERIES AND μPD78058F, 78058FY SUBSERIES	577
APPENDIX B DEVELOPMENT TOOLS	579
B.1 Language Processing Software	582
B.2 PROM Writing Tools	584
B.2.1 Hardware	584
B.2.2 Software	584
B.3 Debugging Tools	585
B.3.1 Hardware	585
B.3.2 Software	587

B.4 OS for IBM PC	589
B.5 Upgrading Former In-circuit Emulators for 78K/0 Series to IE-78001-R-A	589
APPENDIX C EMBEDDED SOFTWARE	593
APPENDIX D REGISTER INDEX	595
D.1 Register Index	595
APPENDIX E REVISION HISTORY	599

LIST OF FIGURES (1/8)

Figure No.	Title	Page
3-1.	Pin Input/Output Circuit of List	73
4-1.	Pin Input/Output Circuit of List	89
5-1.	Memory Map (μ PD78052, 78052Y)	91
5-2.	Memory Map (μ PD78053, 78053Y)	92
5-3.	Memory Map (μ PD78054, 78054Y)	93
5-4.	Memory Map (μ PD78P054)	94
5-5.	Memory Map (μ PD78055, 78055Y)	95
5-6.	Memory Map (μ PD78056, 78056Y)	96
5-7.	Memory Map (μ PD78058, 78058Y)	97
5-8.	Memory Map (μ PD78P058, μ PD78P058Y)	98
5-9.	Data Memory Addressing (μ PD78052, 78052Y)	101
5-10.	Data Memory Addressing (μ PD78053, 78053Y)	102
5-11.	Data Memory Addressing (μ PD78054, 78054Y)	103
5-12.	Data Memory Addressing (μ PD78P054)	104
5-13.	Data Memory Addressing (μ PD78055, 78055Y)	105
5-14.	Data Memory Addressing (μ PD78056, 78056Y)	106
5-15.	Data Memory Addressing (μ PD78058, 78058Y)	107
5-16.	Data Memory Addressing (μ PD78P058, 78P058Y)	108
5-17.	Program Counter Configuration	109
5-18.	Program Status Word Configuration	109
5-19.	Stack Pointer Configuration	111
5-20.	Data to be Saved to Stack Memory	111
5-21.	Data to be Reset from Stack Memory	111
5-22.	General Register Configuration	113
6-1.	Port Types	129
6-2.	P00 and P07 Block Diagram	135
6-3.	P01 to P06 Block Diagram	135
6-4.	P10 to P17 Block Diagram	136
6-5.	P20, P21, P23 to P26 Block Diagram	137
6-6.	P22 and P27 Block Diagram	138
6-7.	P20, P21, P23 to P26 Block Diagram	139
6-8.	P22 and P27 Block Diagram	140
6-9.	P30 to P37 Block Diagram	141
6-10.	P40 to P47 Block Diagram	142
6-11.	Block Diagram of Falling Edge Detection Circuit	142
6-12.	P50 to P57 Block Diagram	143
6-13.	P60 to P63 Block Diagram	145
6-14.	P64 to P67 Block Diagram	145
6-15.	P70 Block Diagram	146
6-16.	P71 and P72 Block Diagram	147
6-17.	P120 to P127 Block Diagram	148

LIST OF FIGURES (2/8)

Figure No.	Title	Page
6-18.	P130 and P131 Block Diagram	149
6-19.	Port Mode Register Format	152
6-20.	Pull-Up Resistor Option Register Format	153
6-21.	Memory Expansion Mode Register Format	154
6-22.	Key Return Mode Register Format	155
7-1.	Block Diagram of Clock Generator	160
7-2.	Subsystem Clock Feedback Resistor	161
7-3.	Processor Clock Control Register Format	162
7-4.	Oscillation Mode Selection Register Format	164
7-5.	Main System Clock when Writing to OSMS	164
7-6.	External Circuit of Main System Clock Oscillator	165
7-7.	External Circuit of Subsystem Clock Oscillator	166
7-8.	Examples of Incorrect Oscillator Connection	166
7-9.	Main System Clock Stop Function	170
7-10.	System Clock and CPU Clock Switching	173
8-1.	16-Bit Timer/Event Counter Block Diagram	179
8-2.	16-Bit Timer/Event Counter Output Control Circuit Block Diagram	180
8-3.	Timer Clock Selection Register 0 Format	183
8-4.	16-Bit Timer Mode Control Register Format	185
8-5.	Capture/Compare Control Register 0 Format	186
8-6.	16-Bit Timer Output Control Register Format	187
8-7.	Port Mode Register 3 Format	188
8-8.	External Interrupt Mode Register 0 Format	189
8-9.	Sampling Clock Select Register Format	190
8-10.	Control Register Settings for Interval Timer Operation	191
8-11.	Interval Timer Configuration Diagram	192
8-12.	Interval Timer Operation Timings	192
8-13.	Control Register Settings for PWM Output Operation	194
8-14.	Example of D/A Converter Configuration with PWM Output	195
8-15.	TV Tuner Application Circuit Example	195
8-16.	Control Register Settings for PPG Output Operation	196
8-17.	Control Register Settings for Pulse Width Measurement with Free-Running Counter and One Capture Register	197
8-18.	Configuration Diagram for Pulse Width Measurement by Free-Running Counter	198
8-19.	Timing of Pulse Width Measurement Operation by Free-Running Counter and One Capture Register (with Both Edges Specified)	198
8-20.	Control Register Settings for Two Pulse Width Measurements with Free-Running Counter	199
8-21.	Timing of Pulse Width Measurement Operation with Free-Running Counter (with Both Edges Specified)	200
8-22.	Control Register Settings for Pulse Width Measurement with Free-Running Counter and Two Capture Registers	201

LIST OF FIGURES (3/8)

Figure No.	Title	Page
8-23.	Timing of Pulse Width Measurement Operation by Free-Running Counter and Two Capture Registers (with Rising Edge Specified)	202
8-24.	Control Register Settings for Pulse Width Measurement by Means of Restart	203
8-25.	Timing of Pulse Width Measurement Operation by Means of Restart (with Rising Edge Specified)	203
8-26.	Control Register Settings in External Event Counter Mode	204
8-27.	External Event Counter Configuration Diagram	205
8-28.	External Event Counter Operation Timings (with Rising Edge Specified)	205
8-29.	Control Register Settings in Square-Wave Output Mode	206
8-30.	Square-Wave Output Operation Timing	207
8-31.	Control Register Settings for One-Shot Pulse Output Operation Using Software Trigger	208
8-32.	Timing of One-Shot Pulse Output Operation Using Software Trigger	209
8-33.	Control Register Settings for One-Shot Pulse Output Operation Using External Trigger	210
8-34.	Timing of One-Shot Pulse Output Operation Using External Trigger (With Rising Edge Specified)	211
8-35.	16-Bit Timer Register Start Timing	212
8-36.	Timings After Change of Compare Register During Timer Count Operation	212
8-37.	Capture Register Data Retention Timing	213
8-38.	Operation Timing of OVFO Flag	214
9-1.	8-Bit Timer/Event Counters 1 and 2 Block Diagram	221
9-2.	Block Diagram of 8-Bit Timer/Event Counter Output Control Circuit 1	222
9-3.	Block Diagram of 8-Bit Timer/Event Counter Output Control Circuit 2	222
9-4.	Timer Clock Select Register 1 Format	224
9-5.	8-Bit Timer Mode Control Register 1 Format	225
9-6.	8-Bit Timer Output Control Register Format	226
9-7.	Port Mode Register 3 Format	227
9-8.	Interval Timer Operation Timings	228
9-9.	External Event Counter Operation Timings (with Rising Edge Specified)	231
9-10.	Square-Wave Output Operation Timing	233
9-11.	Interval Timer Operation Timing	234
9-12.	External Event Counter Operation Timings (with Rising Edge Specified)	236
9-13.	Square-Wave Output Operation Timing	238
9-14.	8-Bit Timer Registers 1 and 2 Start Timing	238
9-15.	Event Counter Operation Timing	239
9-16.	Timing after Compare Register Change during Timer Count Operation	239
10-1.	Watch Timer Block Diagram	243
10-2.	Timer Clock Select Register 2 Format	244
10-3.	Watch Timer Mode Control Register Format	245
11-1.	Watchdog Timer Block Diagram	249
11-2.	Timer Clock Select Register 2 Format	251
11-3.	Watchdog Timer Mode Register Format	252

LIST OF FIGURES (4/8)

Figure No.	Title	Page
12-1.	Remote Controlled Output Application Example	255
12-2.	Clock Output Control Circuit Block Diagram	256
12-3.	Timer Clock Select Register 0 Format	258
12-4.	Port Mode Register 3 Format	259
13-1.	Buzzer Output Control Circuit Block Diagram	261
13-2.	Timer Clock Select Register 2 Format	263
13-3.	Port Mode Register 3 Format	264
14-1.	A/D Converter Block Diagram	266
14-2.	Handling of AV _{DD} Pin	268
14-3.	A/D Converter Mode Register Format	270
14-4.	A/D Converter Input Select Register Format	271
14-5.	External Interrupt Mode Register 1 Format	272
14-6.	A/D Converter Basic Operation	274
14-7.	Relations between Analog Input Voltage and A/D Conversion Result	275
14-8.	A/D Conversion by Hardware Start	276
14-9.	A/D Conversion by Software Start	277
14-10.	Example of Method of Reducing Current Dissipation in Standby Mode	278
14-11.	Analog Input Pin Disposition	279
14-12.	A/D Conversion End Interrupt Request Generation Timing	280
14-13.	Handling of AV _{DD} Pin	280
15-1.	D/A Converter Block Diagram	282
15-2.	D/A Converter Mode Register Format	284
15-3.	Use Example of Buffer Amplifier	286
16-1.	Serial Bus Interface (SBI) System Configuration Example	289
16-2.	Serial Interface Channel 0 Block Diagram	291
16-3.	Timer Clock Select Register 3 Format	295
16-4.	Serial Operating Mode Register 0 Format	296
16-5.	Serial Bus Interface Control Register Format	298
16-6.	Interrupt Timing Specify Register Format	300
16-7.	3-Wire Serial I/O Mode Timings	305
16-8.	RELT and CMDT Operations	305
16-9.	Circuit of Switching in Transfer Bit Order	306
16-10.	Example of Serial Bus Configuration with SBI	307
16-11.	SBI Transfer Timings	309
16-12.	Bus Release Signal	310
16-13.	Command Signal	310
16-14.	Addresses	311
16-15.	Slave Selection with Address	311
16-16.	Commands	312

LIST OF FIGURES (5/8)

Figure No.	Title	Page
16-17.	Data	312
16-18.	Acknowledge Signal	313
16-19.	BUSY and READY Signals	314
16-20.	RELT, CMDT, RELD, and CMDD Operations (Master)	319
16-21.	RELT and CMDD Operations (Slave)	319
16-22.	ACKT Operation	320
16-23.	ACKE Operations	321
16-24.	ACKD Operations	322
16-25.	BSYE Operation	322
16-26.	Pin Configuration	325
16-27.	Address Transmission from Master Device to Slave Device (WUP = 1)	327
16-28.	Command Transmission from Master Device to Slave Device	328
16-29.	Data Transmission from Master Device to Slave Device	329
16-30.	Data Transmission from Slave Device to Master Device	330
16-31.	Serial Bus Configuration Example Using 2-Wire Serial I/O Mode	333
16-32.	2-Wire Serial I/O Mode Timings	337
16-33.	RELT and CMDT Operations	338
16-34.	$\overline{SCK0}$ /P27 Pin Configuration	339
17-1.	Serial Bus Configuration Example Using I ² C Bus	343
17-2.	Serial Interface Channel 0 Block Diagram	345
17-3.	Timer Clock Select Register 3 Format	349
17-4.	Serial Operating Mode Register 0 Format	351
17-5.	Serial Bus Interface Control Register Format	352
17-6.	Interrupt Timing Specify Register Format	354
17-7.	3-Wire Serial I/O Mode Timings	359
17-8.	RELT and CMDT Operations	359
17-9.	Circuit of Switching in Transfer Bit Order	360
17-10.	Serial Bus Configuration Example Using 2-Wire Serial I/O Mode	361
17-11.	2-Wire Serial I/O Mode Timings	365
17-12.	RELT and CMDT Operations	366
17-13.	Example of Serial Bus Configuration Using I ² C Bus	367
17-14.	I ² C Bus Serial Data Transfer Timing	368
17-15.	Start Condition	369
17-16.	Address	369
17-17.	Transfer Direction Specification	369
17-18.	Acknowledge Signal	370
17-19.	Stop Condition	370
17-20.	Wait Signal	371
17-21.	Pin Configuration	377
17-22.	Data Transmission from Master to Slave (Both Master and Slave Selected 9-Clock Wait)	379
17-23.	Data Transmission from Slave to Master (Both Master and Slave Selected 9-Clock Wait)	382
17-24.	Start Condition Output	385
17-25.	Slave Wait Release (Transmission)	386

LIST OF FIGURES (6/8)

Figure No.	Title	Page
17-26.	Slave Wait Release (Reception)	387
17-27.	$\overline{SCK0}$ /SCL/P27 Pin Configuration	390
17-28.	$\overline{SCK0}$ /SCL/P27 Pin Configuration	390
17-29.	Logic Circuit of SCL Signal	391
18-1.	Serial Interface Channel 1 Block Diagram	395
18-2.	Timer Clock Select Register 3 Format	398
18-3.	Serial Operation Mode Register 1 Format	399
18-4.	Automatic Data Transmit/Receive Control Register Format	400
18-5.	Automatic Data Transmit/Receive Interval Specify Register Format	401
18-6.	3-Wire Serial I/O Mode Timings	407
18-7.	Circuit of Switching in Transfer Bit Order	408
18-8.	Basic Transmission/Reception Mode Operation Timings	417
18-9.	Basic Transmission/Reception Mode Flowchart	418
18-10.	Buffer RAM Operation in 6-Byte Transmission/Reception (in Basic Transmit/Receive Mode)	419
18-11.	Basic Transmission Mode Operation Timings	421
18-12.	Basic Transmission Mode Flowchart	422
18-13.	Buffer RAM Operation in 6-Byte Transmission (in Basic Transmit Mode)	423
18-14.	Repeat Transmission Mode Operation Timing	425
18-15.	Repeat Transmission Mode Flowchart	426
18-16.	Buffer RAM Operation in 6-Byte Transmission (in Repeat Transmit Mode)	427
18-17.	Automatic Transmission/Reception Suspension and Restart	429
18-18.	System Configuration When the Busy Control Option is Used	430
18-19.	Operation Timings when Using Busy Control Option (BUSY0 = 0)	431
18-20.	Busy Signal and Wait Cancel (when BUSY0 = 0)	432
18-21.	Operation Timings when Using Busy & Strobe Control Option (BUSY0 = 0)	433
18-22.	Operation Timing of the Bit Slippage Detection Function Through the Busy Signal (when BUSY0 = 1)	434
18-23.	Automatic Data Transmit/Receive Interval	435
18-24.	Operation Timing with Automatic Data Transmit/Receive Function Performed by Internal Clock	436
19-1.	Serial Interface Channel 2 Block Diagram	441
19-2.	Baud Rate Generator Block Diagram	442
19-3.	Serial Operating Mode Register 2 Format	444
19-4.	Asynchronous Serial Interface Mode Register Format	445
19-5.	Asynchronous Serial Interface Status Register Format	447
19-6.	Baud Rate Generator Control Register Format	448
19-7.	Asynchronous Serial Interface Transmit/Receive Data Format	461
19-8.	Asynchronous Serial Interface Transmission Completion Interrupt Request Generation Timing ..	463
19-9.	Asynchronous Serial Interface Reception Completion Interrupt Request Generation Timing	464
19-10.	Receive Error Timing	465
19-11.	The State of Receive Buffer Register (RXB) and Whether the Receive Completion Interrupt Request (INTSR) is Generated	466

LIST OF FIGURES (7/8)

Figure No.	Title	Page
19-12.	3-Wire Serial I/O Mode Timing	472
19-13.	Circuit of Switching in Transfer Bit Order	473
19-14.	Reception Completion Interrupt Request Generation Timing (when ISRM = 1)	474
19-15.	Receive Buffer Register Read Disable Period	475
20-1.	Real-time Output Port Block Diagram	478
20-2.	Real-time Output Buffer Register Configuration	479
20-3.	Port Mode Register 12 Format	480
20-4.	Real-time Output Port Mode Register Format	480
20-5.	Real-time Output Port Control Register Format	481
21-1.	Basic Configuration of Interrupt Function	486
21-2.	Interrupt Request Flag Register Format	489
21-3.	Interrupt Mask Flag Register Format	490
21-4.	Priority Specify Flag Register Format	491
21-5.	External Interrupt Mode Register 0 Format	492
21-6.	External Interrupt Mode Register 1 Format	493
21-7.	Sampling Clock Select Register Format	494
21-8.	Noise Eliminator Input/Output Timing (during rising edge detection)	495
21-9.	Program Status Word Configuration	496
21-10.	Flowchart of Generation from Non-Maskable Interrupt Request to Acknowledgment	498
21-11.	Non-Maskable Interrupt Request Acknowledge Timing	498
21-12.	Non-Maskable Interrupt Request Acknowledge Operation	499
21-13.	Interrupt Request Acknowledge Processing Algorithm	501
21-14.	Interrupt Request Acknowledge Timing (Minimum Time)	502
21-15.	Interrupt Request Acknowledge Timing (Maximum Time)	502
21-16.	Multiple Interrupt Example	504
21-17.	Interrupt Request Hold	506
21-18.	Basic Configuration of Test Function	507
21-19.	Format of Interrupt Request Flag Register 1L	508
21-20.	Format of Interrupt Mask Flag Register 1L	508
21-21.	Key Return Mode Register Format	509
22-1.	Memory Map when Using External Device Expansion Function	512
22-2.	Memory Expansion Mode Register Format	516
22-3.	Memory Size Switching Register Format	517
22-4.	Instruction Fetch from External Memory	519
22-5.	External Memory Read Timing	520
22-6.	External Memory Write Timing	521
22-7.	External Memory Read Modify Write Timing	522
22-8.	Connection Example of μ PD78054 and Memory	523
23-1.	Oscillation Stabilization Time Select Register Format	526
23-2.	HALT Mode Clear upon Interrupt Request Generation	528

LIST OF FIGURES (8/8)

Figure No.	Title	Page
23-3.	HALT Mode Release by $\overline{\text{RESET}}$ Input	529
23-4.	STOP Mode Release by Interrupt Request Generation	531
23-5.	Release by STOP Mode $\overline{\text{RESET}}$ Input	532
24-1.	Block Diagram of Reset Function	533
24-2.	Timing of Reset Input by $\overline{\text{RESET}}$ Input	534
24-3.	Timing of Reset due to Watchdog Timer Overflow	534
24-4.	Timing of Reset Input in STOP Mode by $\overline{\text{RESET}}$ Input	534
25-1.	Block Diagram of ROM Correction	537
25-2.	Correction Address Registers 0 and 1 Format	538
25-3.	Correction Control Register Format	539
25-4.	Storing Example to EEPROM (when one place is corrected)	540
25-5.	Connecting Example with EEPROM (using 2-wire serial I/O mode)	540
25-6.	Initialization Routine	541
25-7.	ROM Correction Operation	542
25-8.	ROM Correction Example	543
25-9.	Program Transition Diagram (when one place is corrected)	544
25-10.	Program Transition Diagram (when two places are corrected)	545
26-1.	Memory Size Switching Register Format ($\mu\text{PD78P054}$)	549
26-2.	Memory Size Switching Register Format ($\mu\text{PD78P058}$)	550
26-3.	Internal Expansion RAM Size Switching Register Format	551
26-4.	Page Program Mode Flowchart	554
26-5.	Page Program Mode Timing	555
26-6.	Byte Program Mode Flowchart	556
26-7.	Byte Program Mode Timing	557
26-8.	PROM Read Timing	558
B-1.	Development Tool Configuration	580
B-2.	EV-9200GC-80 Drawing (For Reference Only)	590
B-3.	EV-9200GC-80 Footprint (For Reference Only)	591
B-4.	TGK-080SDW Drawing (For Reference) (unit: mm)	592

LIST OF TABLES (1/3)

Table No.	Title	Page
1-1.	Differences between Standard Quality Grade Products and (A) Products	48
1-2.	Mask Options of Mask ROM Versions	48
2-1.	Mask Options of Mask ROM Versions	58
3-1.	Pin Input/Output Circuit Types	71
4-1.	Pin Input/Output Circuit Types	87
5-1.	Internal ROM Capacity	99
5-2.	Vector Table	99
5-3.	Internal High-Speed RAM Capacity	100
5-4.	Internal High-Speed RAM Area	110
5-5.	Correspondent Table of Absolute Addresses in the General Registers	112
5-6.	Special-Function Register List	115
6-1.	Port Functions (μ PD78054 subseries)	130
6-2.	Port Functions (μ PD78054Y subseries)	132
6-3.	Port Configuration	134
6-4.	Pull-up Resistor of Port 6	144
6-5.	Port Mode Register and Output Latch Settings when Using Dual-Functions	151
6-6.	Comparison between Mask ROM Version and PROM Version	157
7-1.	Clock Generator Configuration	159
7-2.	Relationship between CPU Clock and Minimum Instruction Execution Time	163
7-3.	Maximum Time Required for CPU Clock Switchover	172
8-1.	Timer/Event Counter Operations	176
8-2.	16-Bit Timer/Event Counter Interval Times	177
8-3.	16-Bit Timer/Event Counter Square-Wave Output Ranges	178
8-4.	16-Bit Timer/Event Counter Configuration	179
8-5.	INTP0/TI00 Pin Valid Edge and CR00 Capture Trigger Valid Edge	181
8-6.	16-Bit Timer/Event Counter Interval Times	193
8-7.	16-Bit Timer/Event Count Square-Wave Output Ranges	207
9-1.	8-Bit Timer/Event Counters 1 and 2 Interval Times	216
9-2.	8-Bit Timer/Event Counters 1 and 2 Square-Wave Output Ranges	217
9-3.	Interval Times when 8-Bit Timer/Event Counters 1 and 2 are Used as 16-Bit Timer/Event Counters	218
9-4.	Square-Wave Output Ranges when 8-Bit Timer/Event Counters 1 and 2 are Used as 16-Bit Timer/Event Counters	219
9-5.	8-Bit Timer/Event Counters 1 and 2 Configurations	220
9-6.	8-Bit Timer/Event Counter 1 Interval Time	229
9-7.	8-Bit Timer/Event Counter 2 Interval Time	230

LIST OF TABLES (2/3)

Table No.	Title	Page
9-8.	8-Bit Timer/Event Counters 1 and 2 Square-Wave Output Ranges	232
9-9.	Interval Times when 2-Channel 8-Bit Timer/ Event Counters (TM1 and TM2) are Used as 16-Bit Timer/Event Counter	235
9-10.	Square-Wave Output Ranges when 2-Channel 8-Bit Timer/ Event Counters (TM1 and TM2) are Used as 16-Bit Timer/Event Counter	237
10-1.	Interval Timer Interval Time	241
10-2.	Watch Timer Configuration	242
10-3.	Interval Timer Interval Time	246
11-1.	Watchdog Timer Runaway Detection Times	247
11-2.	Interval Times	248
11-3.	Watchdog Timer Configuration	249
11-4.	Watchdog Timer Runaway Detection Times	253
11-5.	Interval Timer Interval Time	254
12-1.	Clock Output Control Circuit Configuration	256
13-1.	Buzzer Output Control Circuit Configuration	261
14-1.	A/D Converter Configuration	265
15-1.	D/A Converter Configuration	282
16-1.	Differences between Channels 0, 1, and 2	287
16-2.	Serial Interface Channel 0 Configuration	290
16-3.	Various Signals in SBI Mode	323
17-1.	Differences between Channels 0, 1, and 2	341
17-2.	Serial Interface Channel 0 Configuration	344
17-3.	Serial Interface Channel 0 Interrupt Request Signal Generation	347
17-4.	Signals in I ² C Bus Mode	376
18-1.	Serial Interface Channel 1 Configuration	394
18-2.	Interval Timing Through CPU Processing (when the internal clock is operating)	436
18-3.	Interval Timing Through CPU Processing (when the external clock is operating)	437
19-1.	Serial Interface Channel 2 Configuration	440
19-2.	Serial Interface Channel 2 Operating Mode Settings	446
19-3.	Relation between Main System Clock and Baud Rate	450
19-4.	Relation between ASCK Pin Input Frequency and Baud Rate (When BRGC is set to 00H)	451
19-5.	Relation between Main System Clock and Baud Rate	459
19-6.	Relation between ASCK Pin Input Frequency and Baud Rate (When BRGC is set to 00H)	460

LIST OF TABLES (3/3)

Table No.	Title	Page
19-7.	Receive Error Causes	465
20-1.	Real-time Output Port Configuration	478
20-2.	Operation in Real-time Output Buffer Register Manipulation	479
20-3.	Real-time Output Port Operating Mode and Output Trigger	481
21-1.	Interrupt Source List	484
21-2.	Various Flags Corresponding to Interrupt Request Sources	488
21-3.	Times from Maskable Interrupt Request Generation to Interrupt Service	500
21-4.	Interrupt Request Enabled for Multiple Interrupt during Interrupt Servicing	503
21-5.	Test Input Factors	507
21-6.	Flags Corresponding to Test Input Signals	507
22-1.	Pin Functions in External Memory Expansion Mode	511
22-2.	State of Ports 4 to 6 Pins in External Memory Expansion Mode	511
22-3.	Values when the Memory Size Switching Register is Reset	517
23-1.	HALT Mode Operating Status	527
23-2.	Operation after HALT Mode Release	529
23-3.	STOP Mode Operating Status	530
23-4.	Operation after STOP Mode Release	532
24-1.	Hardware Status after Reset	535
25-1.	ROM Correction Configuration	537
26-1.	Differences between μ PD78P054, 78P058 and Mask ROM Versions	547
26-2.	Differences between μ PD78P054 and 78P058	548
26-3.	Examples of Memory Size Switching Register Settings (μ PD78P054)	549
26-4.	Examples of Memory Size Switching Register Settings (μ PD78P058)	550
26-5.	Value Set to the Internal Expansion RAM Size Switching Register	551
26-6.	PROM Programming Operating Modes	552
27-1.	Operand Identifiers and Description Methods	562
A-1.	Major differences between μ PD78054, 78054Y Subseries and μ PD78058F, 78058FY Subseries	578
B-1.	OS for IBM PC	589
B-2.	Upgrading Former In-circuit Emulators for 78K/0 Series to IE-78001-R-A	589

[MEMO]

CHAPTER 1 GENERAL (μ PD78054 Subseries)

1.1 Features

- On-chip high-capacity ROM and RAM

Type Part Number	Program Memory (ROM)	Data Memory		
		Internal High-Speed RAM	Internal Buffer RAM	Internal Expansion RAM
μ PD78052	16 Kbytes	512 bytes	32 bytes	None
μ PD78053	24 Kbytes	1024 bytes		
μ PD78054	32 Kbytes			
μ PD78P054	32 Kbytes ^{Note1}	1024 bytes ^{Note1}		
μ PD78055	40 Kbytes	1024 bytes		
μ PD78056	48 Kbytes			
μ PD78058	60 Kbytes			1024 bytes
μ PD78P058	60 Kbytes ^{Note1}	1024 bytes ^{Note1}		1024 bytes ^{Note2}

Notes 1. The capacities of internal PROM and internal high-speed RAM can be changed by means of the memory size switching register (IMS).

2. The capacity of internal high-speed RAM can be changed by means of the internal expansion RAM size switching register (IXS).

- External Memory Expansion Space: 64 Kbytes
- Minimum instruction execution time changeable from high speed (0.4 μ s: In main system clock 5.0 MHz operation) to ultra-low speed (122 μ s: In subsystem clock 32.768 kHz operation)
- Instruction set suited to system control
 - Bit manipulation possible in all address spaces
 - Multiply and divide instructions
- 69 I/O ports: (4 N-ch open-drain ports)
- 8-bit resolution A/D converter: 8 channels
- 8-bit resolution D/A converter: 2 channels
- Serial interface: 3 channels
 - 3-wire serial I/O/SBI/2-wire serial I/O mode: 1 channel
 - 3-wire serial I/O mode (Automatic transmit/receive function): 1 channel
 - 3-wire serial I/O/UART mode: 1 channel
- Timer: 5 channels
 - 16-bit timer/event counter : 1 channel
 - 8-bit timer/event counter : 2 channels
 - Watch timer : 1 channel
 - Watchdog timer : 1 channel
- 22 vectored interrupt sources
- 2 test inputs
- Two types of on-chip clock oscillators (main system clock and subsystem clock)
- Supply voltage: $V_{DD} = 2.0$ to 6.0 V

1.2 Applications

μ PD78052, 78053, 78054, 78P054, 78055, 78056, 78058, 78P058:

Cellular phones, pagers, printers, AV equipment, air conditioners, cameras, PPCs, fuzzy home appliances, vending machines, etc.

μ PD78052(A), 78053(A), 78054(A):

Control unit for automobile electronics, gas detector/breaker, various safety unit, etc.

★ 1.3 Ordering Information

Part number	Package	Internal ROM
μ PD78052GC-xxx-8BT	80-pin plastic QFP (14 × 14 mm, Resin thickness: 1.4 mm)	Mask ROM
μ PD78052GK-xxx-BE9	80-pin plastic TQFP (Fine pitch) (12 × 12 mm)	Mask ROM
μ PD78053GC-xxx-8BT	80-pin plastic QFP (14 × 14 mm, Resin thickness: 1.4 mm)	Mask ROM
μ PD78053GK-xxx-BE9	80-pin plastic TQFP (Fine pitch) (12 × 12 mm)	Mask ROM
μ PD78054GC-xxx-8BT	80-pin plastic QFP (14 × 14 mm, Resin thickness: 1.4 mm)	Mask ROM
μ PD78054GK-xxx-BE9	80-pin plastic TQFP (Fine pitch) (12 × 12 mm)	Mask ROM
μ PD78P054GC-3B9	80-pin plastic QFP (14 × 14 mm, Resin thickness: 2.7 mm)	One-time PROM
μ PD78P054GC-8BT ^{Note}	80-pin plastic QFP (14 × 14 mm, Resin thickness: 1.4 mm)	One-time PROM
μ PD78P054GK-BE9	80-pin plastic TQFP (Fine pitch) (12 × 12 mm)	One-time PROM
μ PD78P054KK-T	80-pin ceramic WQFN (14 × 14 mm)	EPROM
μ PD78055GC-xxx-8BT	80-pin plastic QFP (14 × 14 mm, Resin thickness: 1.4 mm)	Mask ROM
μ PD78055GK-xxx-BE9	80-pin plastic TQFP (Fine pitch) (12 × 12 mm)	Mask ROM
μ PD78056GC-xxx-8BT	80-pin plastic QFP (14 × 14 mm, Resin thickness: 1.4 mm)	Mask ROM
μ PD78056GK-xxx-BE9	80-pin plastic TQFP (Fine pitch) (12 × 12 mm)	Mask ROM
μ PD78058GC-xxx-8BT	80-pin plastic QFP (14 × 14 mm, Resin thickness: 1.4 mm)	Mask ROM
μ PD78058GK-xxx-BE9	80-pin plastic TQFP (Fine pitch) (12 × 12 mm)	Mask ROM
μ PD78P058GC-8BT	80-pin plastic QFP (14 × 14 mm, Resin thickness: 1.4 mm)	One-time PROM
μ PD78P058KK-T	80-pin ceramic WQFN (14 × 14 mm)	EPROM
μ PD78052GC(A)-xxx-3B9	80-pin plastic QFP (14 × 14 mm, Resin thickness: 2.7 mm)	Mask ROM
μ PD78053GC(A)-xxx-3B9	80-pin plastic QFP (14 × 14 mm, Resin thickness: 2.7 mm)	Mask ROM
μ PD78054GC(A)-xxx-3B9	80-pin plastic QFP (14 × 14 mm, Resin thickness: 2.7 mm)	Mask ROM

Note Under development

Caution The μ PD78P054GC is available in two packages. For the package that can be supplied, consult NEC.

Remark xxx indicates ROM code suffix.

★ 1.4 Quality Grade

Part number	Package	Quality grade
μ PD78052GC-xxx-8BT	80-pin plastic QFP (14 × 14 mm, Resin thickness: 1.4 mm)	Standard
μ PD78052GK-xxx-BE9	80-pin plastic TQFP (Fine pitch) (12 × 12 mm)	Standard
μ PD78053GC-xxx-8BT	80-pin plastic QFP (14 × 14 mm, Resin thickness: 1.4 mm)	Standard
μ PD78053GK-xxx-BE9	80-pin plastic TQFP (Fine pitch) (12 × 12 mm)	Standard
μ PD78054GC-xxx-8BT	80-pin plastic QFP (14 × 14 mm, Resin thickness: 1.4 mm)	Standard
μ PD78054GK-xxx-BE9	80-pin plastic TQFP (Fine pitch) (12 × 12 mm)	Standard
μ PD78P054GC-3B9	80-pin plastic QFP (14 × 14 mm, Resin thickness: 2.7 mm)	Standard
μ PD78P054GC-8BT ^{Note}	80-pin plastic QFP (14 × 14 mm, Resin thickness: 1.4 mm)	Standard
μ PD78P054GK-BE9	80-pin plastic TQFP (Fine pitch) (12 × 12 mm)	Standard
μ PD78P054KK-T	80-pin ceramic WQFN (14 × 14 mm)	Not applicable (for function evaluation)
μ PD78055GC-xxx-8BT	80-pin plastic QFP (14 × 14 mm, Resin thickness: 1.4 mm)	Standard
μ PD78055GK-xxx-BE9	80-pin plastic TQFP (Fine pitch) (12 × 12 mm)	Standard
μ PD78056GC-xxx-8BT	80-pin plastic QFP (14 × 14 mm, Resin thickness: 1.4 mm)	Standard
μ PD78056GK-xxx-BE9	80-pin plastic TQFP (Fine pitch) (12 × 12 mm)	Standard
μ PD78058GC-xxx-8BT	80-pin plastic QFP (14 × 14 mm, Resin thickness: 1.4 mm)	Standard
μ PD78058GK-xxx-BE9	80-pin plastic TQFP (Fine pitch) (12 × 12 mm)	Standard
μ PD78P058GC-8BT	80-pin plastic QFP (14 × 14 mm, Resin thickness: 1.4 mm)	Standard
μ PD78P058KK-T	80-pin ceramic WQFN (14 × 14 mm)	Not applicable (for function evaluation)
μ PD78052GC(A)-xxx-3B9	80-pin plastic QFP (14 × 14 mm, Resin thickness: 2.7 mm)	Special
μ PD78053GC(A)-xxx-3B9	80-pin plastic QFP (14 × 14 mm, Resin thickness: 2.7 mm)	Special
μ PD78054GC(A)-xxx-3B9	80-pin plastic QFP (14 × 14 mm, Resin thickness: 2.7 mm)	Special

Note Under development

Cautions 1. The μ PD78P054GC is available in two packages. For the package that can be supplied, consult NEC.

2. The μ PD78054KK-T and 78P058KK-T should be used only for experiment or function evaluation, because they are not intended for use in equipment that will be mass-produced and require high reliability.

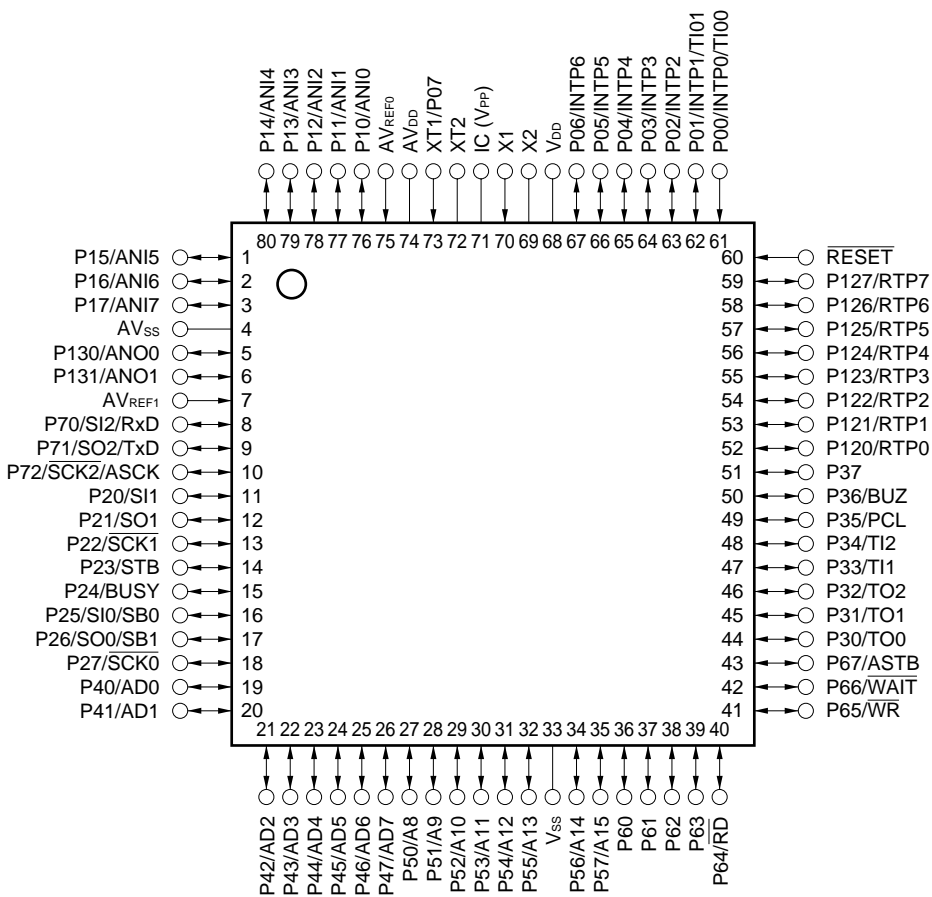
Remark xxx indicates ROM code suffix.

Please refer to "Quality Grades on NEC Semiconductor Devices" (Document number C11531E) published by NEC Corporation to know the specification of quality grade on the devices and its recommended applications.

1.5 Pin Configuration (Top View)

(1) Normal operating mode

- **80-pin plastic QFP (14 × 14 mm, Resin thickness: 2.7 mm)**
 μ PD78P054GC-3B9
- **80-pin plastic QFP (14 × 14 mm, Resin thickness: 1.4 mm)**
 μ PD78052GC-xxx-8BT, 78053GC-xxx-8BT, 78054GC-xxx-8BT, 78P054GC-8BT^{Note}
 μ PD78055GC-xxx-8BT, 78056GC-xxx-8BT, 78058GC-xxx-8BT, 78P058GC-8BT
- **80-pin plastic TQFP (Fine pitch) (12 × 12 mm)**
 μ PD78052GK-xxx-BE9, 78053GK-xxx-BE9, 78054GK-xxx-BE9, 78P054GK-BE9
 μ PD78055GK-xxx-BE9, 78056GK-xxx-BE9, 78058GK-xxx-BE9
- **80-pin ceramic WQFN (14 × 14 mm)**
 μ PD78P054KK-T, 78P058KK-T



Note Under development

- Cautions**
1. Be sure to connect IC (Internally Connected) pin to V_{SS} directly.
 2. Connect AV_{DD} pin to V_{DD}.
 3. Connect AV_{SS} pin to V_{SS}.

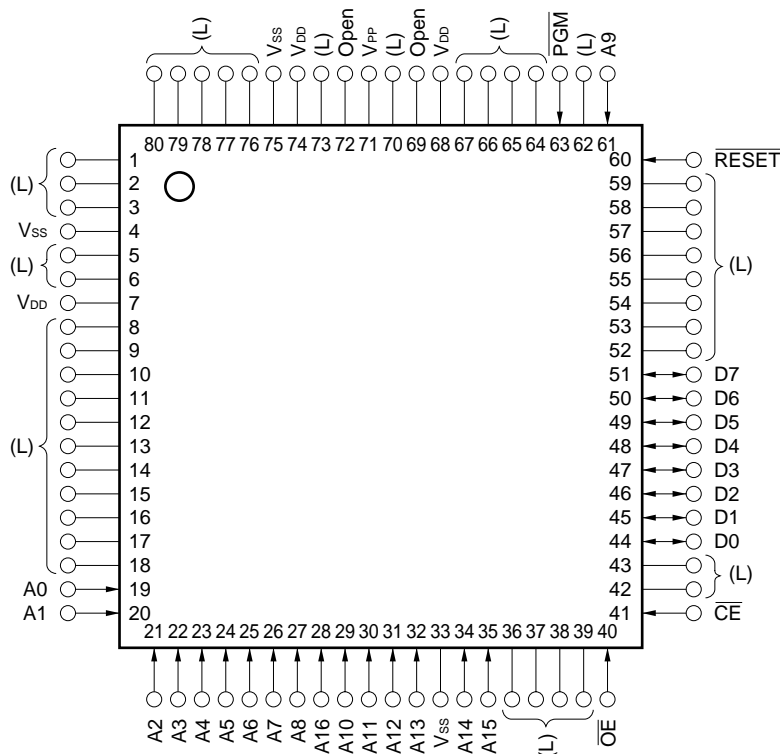
Remark Pin connection in parentheses is intended for the μ PD78P054, 78P058.

Pin Identifications

A8 to A15	: Address Bus	P130, P131	: Port13
AD0 to AD7	: Address/Data Bus	PCL	: Programmable Clock
ANI0 to ANI7	: Analog Input	\overline{RD}	: Read Strobe
ANO0, ANO1	: Analog Output	\overline{RESET}	: Reset
ASCK	: Asynchronous Serial Clock	RTP0 to RTP7	: Real-Time Output Port
ASTB	: Address Strobe	RxD	: Receive Data
AV _{DD}	: Analog Power Supply	SB0, SB1	: Serial Bus
AV _{REF0} , AV _{REF1}	: Analog Reference Voltage	$\overline{SCK0}$ to $\overline{SCK2}$: Serial Clock
AV _{SS}	: Analog Ground	S10 to S12	: Serial Input
BUSY	: Busy	SO0 to SO2	: Serial Output
BUZ	: Buzzer Clock	STB	: Strobe
IC	: Internally Connected	TI00, TI01	: Timer Input
INTP0 to INTP6	: Interrupt from Peripherals	TI1, TI2	: Timer Input
P00 to P07	: Port0	TO0 to TO2	: Timer Output
P10 to P17	: Port1	TxD	: Transmit Data
P20 to P27	: Port2	V _{DD}	: Power Supply
P30 to P37	: Port3	V _{PP}	: Programming Power Supply
P40 to P47	: Port4	V _{SS}	: Ground
P50 to P57	: Port5	\overline{WAIT}	: Wait
P60 to P67	: Port6	\overline{WR}	: Write Strobe
P70 to P72	: Port7	X1, X2	: Crystal (Main System Clock)
P120 to P127	: Port12	XT1, XT2	: Crystal (Subsystem Clock)

(2) PROM programming mode

- **80-pin plastic QFP (14 × 14 mm, Resin thickness: 2.7 mm)**
 μ PD78P054GC-3B9
- **80-pin plastic QFP (14 × 14 mm, Resin thickness: 1.4 mm)**
 μ PD78P054GC-8BT^{Note}, 78P058GC-8BT
- **80-pin plastic TQFP (Fine pitch) (12 × 12 mm)**
 μ PD78P054GK-BE9
- **80-pin ceramic WQFN (14 × 14 mm)**
 μ PD78P054KK-T, 78P058KK-T



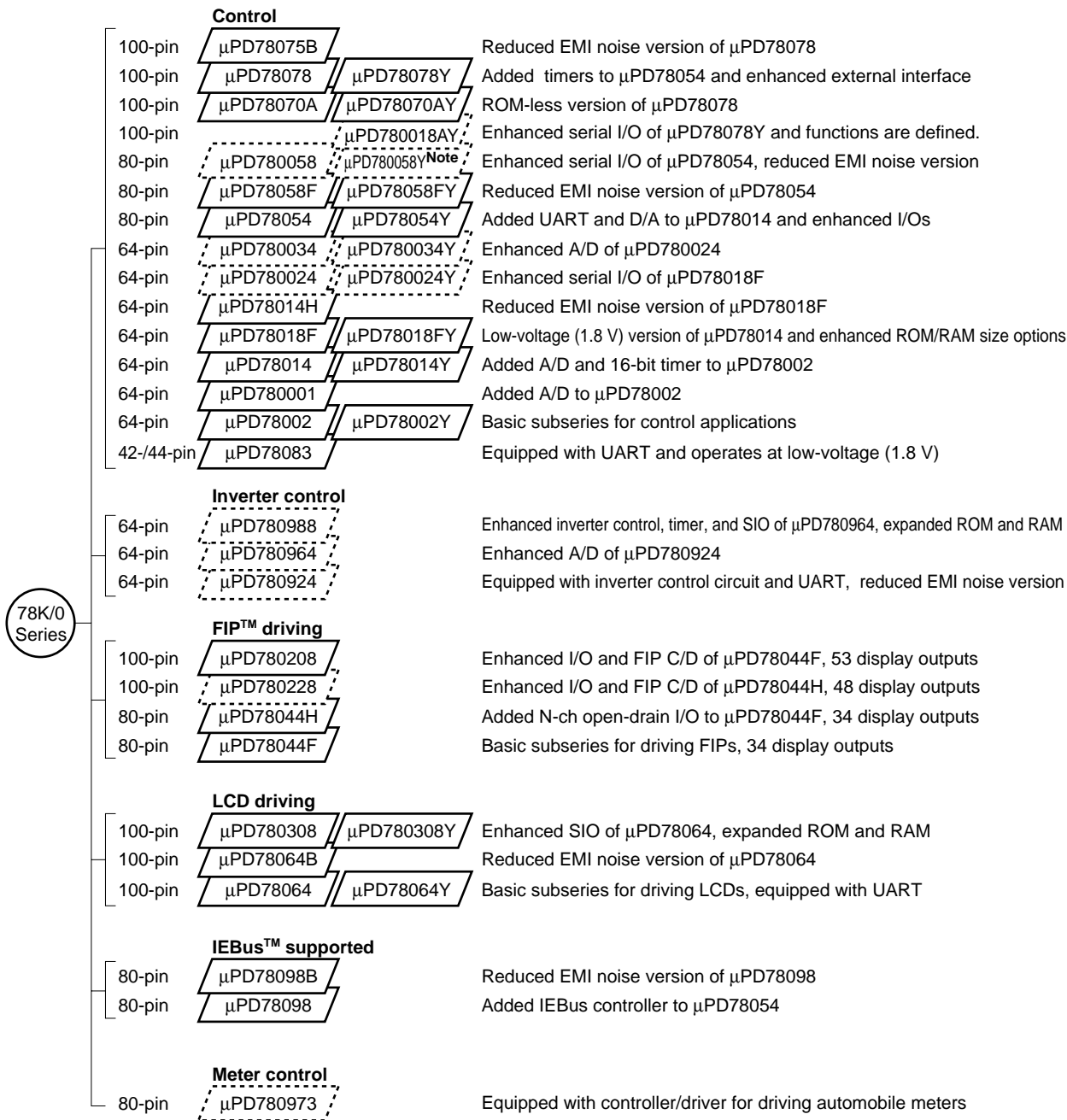
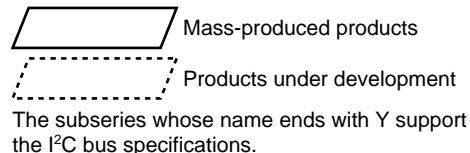
Note Under development

- Cautions**
1. (L) : Connect individually to V_{ss} via a pull-down resistor.
 2. V_{ss} : Connect to the ground.
 3. RESET : Set to the low level.
 4. Open : Leave this pin unconnected.

A0 to A16	: Address Bus	$\overline{\text{RESET}}$: Reset
$\overline{\text{CE}}$: Chip Enable	V _{DD}	: Power Supply
D0 to D7	: Data Bus	V _{PP}	: Programming Power Supply
$\overline{\text{OE}}$: Output Enable	V _{ss}	: Ground
$\overline{\text{PGM}}$: Program		

★ 1.6 78K/0 Series Expansion

The products in the 78K/0 Series are listed below. The names in boxes are subseries names.



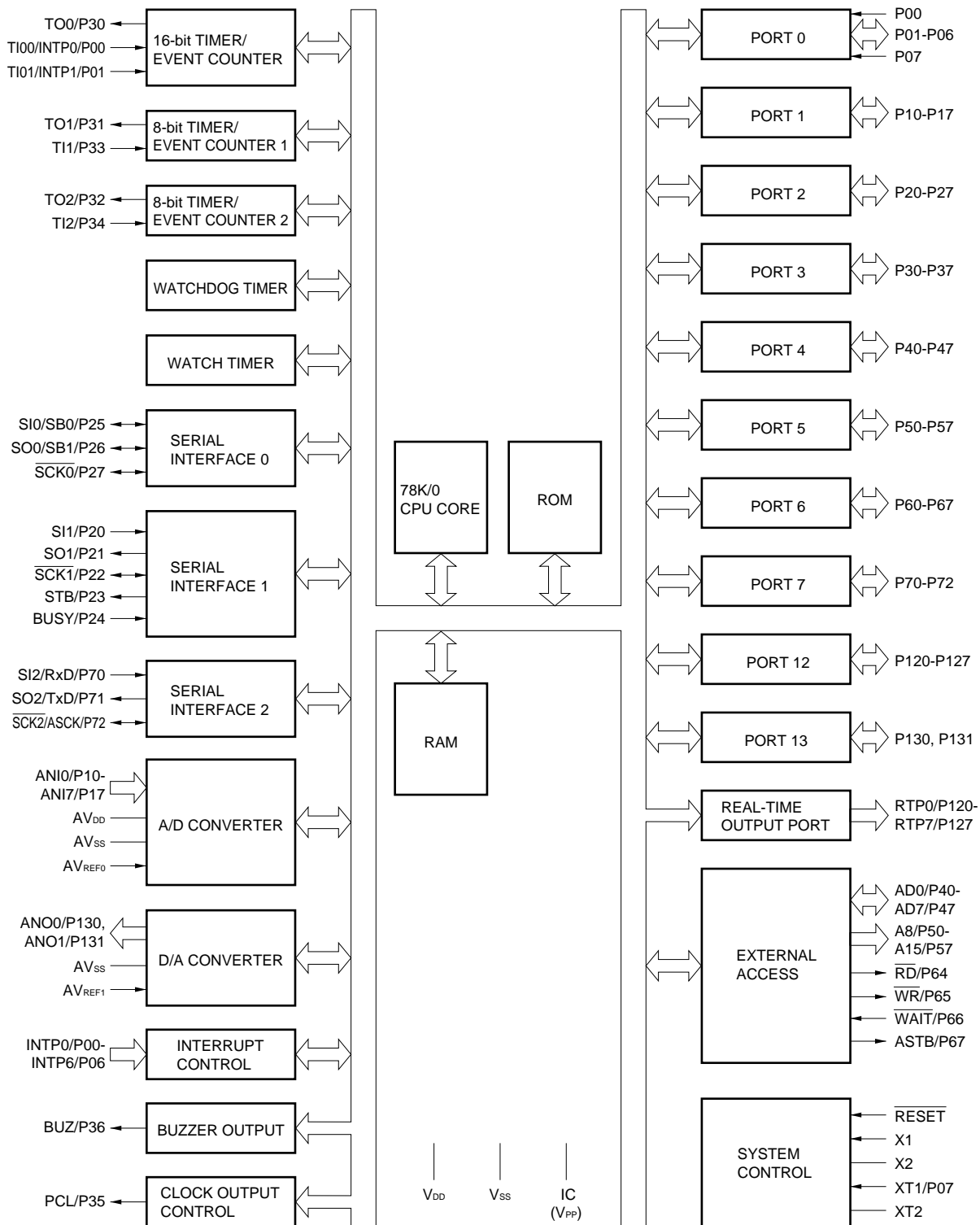
Note Planned

The following shows the major differences between subseries products.

Function Subseries Name		ROM Capacity	Timer				8-bit	10-bit	8-bit	Serial Interface	I/O	V _{DD} MIN. Value	External Expansion
			8-bit	16-bit	Watch	WDT	A/D	A/D	D/A				
Control	μ PD78075B	32 K to 40 K	4 ch	1 ch	1 ch	1 ch	8 ch	-	2 ch	3 ch (UART: 1 ch)	88	1.8 V	√
	μ PD78078	48 K to 60 K									61	2.7 V	
	μ PD78070A	-											
	μ PD780058	24 K to 60 K	2 ch	3 ch (Time division UART: 1 ch)	68	1.8 V							
	μ PD78058F	48 K to 60 K			69	2.7 V							
	μ PD78054	16 K to 60 K			2.0 V								
	μ PD780034	8 K to 32 K			-	8 ch	-	3 ch (UART: 1 ch, Time division 3-wire: 1 ch)	51	1.8 V			
	μ PD780024				8 ch	-							
	μ PD78014H				2 ch	53							
	μ PD78018F	8 K to 60 K			-	-	-	1 ch	39	2.7 V	-		
	μ PD78014	8 K to 32 K											
	μ PD780001	8 K											
	μ PD78002	8 K to 16 K			-	1 ch	-	53	√				
μ PD78083		-			-	8 ch	1 ch (UART: 1 ch)	33	1.8 V	-			
Inverter control	μ PD780988	32 K to 60 K	3 ch	Note 1	-	1 ch	-	8 ch	-	3 ch (UART: 2 ch)	47	4.0 V	√
	μ PD780964	8 K to 32 K		Note 2	2 ch (UART: 2 ch)	2.7 V							
	μ PD780924		8 ch	-									
FIP driving	μ PD780208	32 K to 60 K	2 ch	1 ch	1 ch	1 ch	8 ch	-	-	2 ch	74	2.7 V	-
	μ PD780228	48 K to 60 K								3 ch	-	-	
	μ PD78044H	32 K to 48 K	2 ch	1 ch	1 ch	2 ch	68	2.7 V					
	μ PD78044F	16 K to 40 K											
LCD driving	μ PD780308	48 K to 60 K	2 ch	1 ch	1 ch	1 ch	8 ch	-	-	3 ch (Time division UART: 1 ch)	57	2.0 V	-
	μ PD78064B	32 K								2 ch (UART: 1 ch)			
	μ PD78064	16 K to 32 K											
IEBus supported	μ PD78098B	40 K to 60 K	2 ch	1 ch	1 ch	1 ch	8 ch	-	2 ch	3 ch (UART: 1 ch)	69	2.7 V	√
	μ PD78098	32 K to 60 K											
Meter control	μ PD780973	24 K to 32 K	3 ch	1 ch	1 ch	1 ch	5 ch	-	-	2 ch (UART: 1 ch)	56	4.5 V	-

- Notes**
- 16-bit timer: 2 channels
10-bit timer: 1 channel
 - 10-bit timer: 1 channel

1.7 Block Diagram



- Remarks**
1. The internal ROM and RAM capacities depend on the product.
 2. Pin connection in parentheses is intended for the μ PD78P054, 78P058.

1.8 Outline of Function

Item		Part Number		μ PD78052	μ PD78053	μ PD78054	μ PD78P054	μ PD78055	μ PD78056	μ PD78058	μ PD78P058
								Note 1			
Internal memory	ROM	Mask ROM			PROM			Mask ROM			PROM
		16 Kbytes	24 Kbytes	32 Kbytes	32 Kbytes	40 Kbytes	48 Kbytes	60 Kbytes	60 Kbytes	Note 3	
	High-speed RAM		512 bytes	1024 bytes		1024 bytes	1024 bytes			1024 bytes	Note 3
	Buffer RAM		32 bytes								
	Expansion RAM		None							1024 bytes	1024 bytes
Memory space		64 Kbytes									
General register		8 bits \times 8 \times 4 banks									
Minimum instruction execution time	With main system clock selected	0.4 μ s/0.8 μ s/1.6 μ s/3.2 μ s/6.4 μ s/12.8 μ s (@ 5.0 MHz)									
	With subsystem clock selected	122 μ s (@ 32.768 kHz)									
Instruction set		<ul style="list-style-type: none"> • 16-bit operation • Multiply/divide (8 bits \times 8 bits, 16 bits \div 8 bits) • Bit manipulate (set, reset, test, and Boolean operation) • BCD adjust, etc. 									
I/O port		<ul style="list-style-type: none"> • Total : 69 • CMOS input : 2 • CMOS I/O : 63 • N-ch open-drain I/O : 4 									
A/D converter		8-bit resolution \times 8 channels									
D/A converter		8-bit resolution \times 2 channels									
Serial interface		<ul style="list-style-type: none"> • 3-wire serial I/O/SBI/2-wire serial I/O mode selection possible : 1 channel • 3-wire serial I/O mode (Max. 32-byte on-chip auto-transmit/receive) : 1 channel • 3-wire serial I/O/UART mode selectable : 1 channel 									
Timer		<ul style="list-style-type: none"> • 16-bit timer/event counter : 1 channel • 8-bit timer/event counter : 2 channels • Watch timer : 1 channel • Watchdog timer : 1 channel 									
Timer output		Three outputs: (14-bit PWM output enable: 1)									
Clock output		19.5 kHz, 39.1 kHz, 78.1 kHz, 156 kHz, 313 kHz, 625 kHz, 1.25 MHz, 2.5 MHz, 5.0 MHz (@ 5.0 MHz with main system clock) 32.768 kHz (@ 32.768 kHz with subsystem clock)									
Buzzer output		1.2 kHz, 2.4 kHz, 4.9 kHz, 9.8 kHz (@ 5.0 MHz with main system clock)									

- Notes**
1. The μ PD78P054 is the PROM version for the μ PD78052, 78053, and 78054.
 2. The μ PD78P058 is the PROM version for the μ PD78055, 78056, and 78058.
 3. The capacities of the internal PROM and the internal high-speed RAM can be changed using the memory switching register (IMS).
 4. The capacity of the internal expansion RAM can be changed using the internal expansion RAM size switching register (IXS).

Item		Part Number	μ PD78052	μ PD78053	μ PD78054	μ PD78P054	μ PD78055	μ PD78056	μ PD78058	μ PD78P058
						Note 1				Note2
Vectored interrupt source	Maskable	Internal: 13 External: 7								
	Non-maskable	Internal: 1								
	Software	1								
Test input		Internal: 1 External: 1								
Supply voltage		$V_{DD} = 2.0$ to 6.0 V								
Operating ambient temperature		$T_A = -40$ to $+85^\circ\text{C}$								
Package		<ul style="list-style-type: none"> • 80-pin plastic QFP (14×14 mm, Resin thickness : 2.7 mm) (μPD78P054 only) • 80-pin plastic QFP^{Note 3} (14×14 mm, Resin thickness : 1.4 mm) • 80-pin plastic TQFP (Fine pitch) (12×12 mm) (except μPD78P058) • 80-pin ceramic WQFN (14×14 mm) (μPD78P054, 78P058 only) 								

- Notes**
1. The μ PD78P054 is the PROM version for the μ PD78052, 78053, 78054.
 2. The μ PD78P058 is the PROM version for the μ PD78055, 78056, 78058.
 3. The μ PD78P054 is under development.

1.9 Differences between Standard Quality Grade Products and (A) Products

Table 1-1 shows the differences between the standard quality grade products (μ PD78052, 78053, 78054) and (A) products (μ PD78052(A), 78053(A), 78054(A)).

Table 1-1. Differences between Standard Quality Grade Products and (A) Products

Part Number Item	Standard Quality Grade Products	(A) Products
Quality grade	Standard	Special
Package	<ul style="list-style-type: none"> • 80-pin plastic QFP^{Note 3} (14 × 14 mm, Resin thickness : 1.4 mm) • 80-pin plastic TQFP (Fine pitch) (12 × 12 mm) 	80-pin plastic QFP (14 × 14 mm, Resin thickness : 2.7 mm)
Recommended soldering conditions	Refer to separate Data Sheets	

1.10 Mask Options

The mask ROM versions (μ PD78052, 78053, 78054, 78055, 78056, 78058) provide pull-up resistor mask options which allow users to specify whether to connect a pull-up resistor to a specific port pin when the user places an order for the device production. Using this mask option when pull-up resistors are required reduces the number of components to add to the device, resulting in board space saving.

The mask options provided in the μ PD78054 subseries are shown in Table 1-2.

Table 1-2. Mask Options of Mask ROM Versions

Pin names	Mask options
P60 to P63	Pull-up resistor connection can be specified in 1-bit units.

CHAPTER 2 GENERAL (μ PD78054Y Subseries)

2.1 Features

- On-chip high-capacity ROM and RAM

Type Part Number	Program Memory (ROM)	Data Memory		
		Internal High-Speed RAM	Internal Buffer RAM	Internal Expansion RAM
μ PD78052Y	16 Kbytes	512 bytes	32 bytes	None
μ PD78053Y	24 Kbytes	1024 bytes		
μ PD78054Y	32 Kbytes			
μ PD78055Y	40 Kbytes			
μ PD78056Y	48 Kbytes			
μ PD78058Y	60 Kbytes			1024 bytes
μ PD78P058Y	60 Kbytes ^{Note 1}	1024 bytes ^{Note 1}		1024 bytes ^{Note 2}

- Notes**
1. The capacities of internal PROM and internal high-speed RAM can be changed by means of the memory size switching register (IMS).
 2. The capacity of internal high-speed RAM can be changed by means of the internal expansion RAM size switching register (IXS).

- External Memory Expansion Space: 64 Kbytes
- Minimum instruction execution time changeable from high speed (0.4 μ s: In main system clock 5.0 MHz operation) to ultra-low speed (122 μ s: In subsystem clock 32.768 kHz operation)
- Instruction set suited to system control
 - Bit manipulation possible in all address spaces
 - Multiply and divide instructions
- I/O ports: 69 (N-ch open-drain ports: 4)
- 8-bit resolution A/D converter: 8 channels
- 8-bit resolution D/A converter: 2 channels
- Serial interface: 3 channels
 - 3-wire serial I/O/2-wire serial I/O/I²C bus mode: 1 channel
 - 3-wire serial I/O mode (Automatic transmit/receive function): 1 channel
 - 3-wire serial I/O/UART mode: 1 channel
- Timer: Five channels
 - 16-bit timer/event counter : 1 channel
 - 8-bit timer/event counter : 2 channels
 - Watch timer : 1 channel
 - Watchdog timer : 1 channel
- 22 vectored interrupt sources
- 2 test inputs
- Two types of on-chip clock oscillators (main system clock and subsystem clock)
- Supply voltage: $V_{DD} = 2.0$ to 6.0 V

2.2 Applications

Cellular phones, pagers, printers, AV equipment, air conditioners, cameras, PPCs, fuzzy home appliances, vending machines, etc.

★ 2.3 Ordering Information

Part number	Package	Internal ROM
μ PD78052YGC-xxx-8BT	80-pin plastic QFP (14 × 14 mm, Resin thickness: 1.4 mm)	Mask ROM
μ PD78053YGC-xxx-8BT	80-pin plastic QFP (14 × 14 mm, Resin thickness: 1.4 mm)	Mask ROM
μ PD78054YGC-xxx-8BT	80-pin plastic QFP (14 × 14 mm, Resin thickness: 1.4 mm)	Mask ROM
μ PD78055YGC-xxx-8BT	80-pin plastic QFP (14 × 14 mm, Resin thickness: 1.4 mm)	Mask ROM
μ PD78056YGC-xxx-8BT	80-pin plastic QFP (14 × 14 mm, Resin thickness: 1.4 mm)	Mask ROM
μ PD78058YGC-xxx-8BT	80-pin plastic QFP (14 × 14 mm, Resin thickness: 1.4 mm)	Mask ROM
μ PD78P058YGC-8BT	80-pin plastic QFP (14 × 14 mm, Resin thickness: 1.4 mm)	One-time PROM
μ PD78P058YKK-T	80-pin ceramic WQFN (14 × 14 mm)	EPROM

Remark xxx indicates ROM code suffix.

★ 2.4 Quality Grade

Part number	Package	Quality grade
μ PD78052YGC-xxx-8BT	80-pin plastic QFP (14 × 14 mm, Resin thickness: 1.4 mm)	Standard
μ PD78053YGC-xxx-8BT	80-pin plastic QFP (14 × 14 mm, Resin thickness: 1.4 mm)	Standard
μ PD78054YGC-xxx-8BT	80-pin plastic QFP (14 × 14 mm, Resin thickness: 1.4 mm)	Standard
μ PD78055YGC-xxx-8BT	80-pin plastic QFP (14 × 14 mm, Resin thickness: 1.4 mm)	Standard
μ PD78056YGC-xxx-8BT	80-pin plastic QFP (14 × 14 mm, Resin thickness: 1.4 mm)	Standard
μ PD78058YGC-xxx-8BT	80-pin plastic QFP (14 × 14 mm, Resin thickness: 1.4 mm)	Standard
μ PD78P058YGC-8BT	80-pin plastic QFP (14 × 14 mm, Resin thickness: 1.4 mm)	Standard
μ PD78P058YKK-T	80-pin ceramic WQFN (14 × 14 mm)	Not applicable (for function evaluation)

Remark xxx indicates ROM code suffix.

Please refer to "Quality Grades on NEC Semiconductor Devices" (Document number C11531E) published by NEC Corporation to know the specification of quality grade on the devices and its recommended applications.

2.5 Pin Configuration (Top View)

(1) Normal operating mode

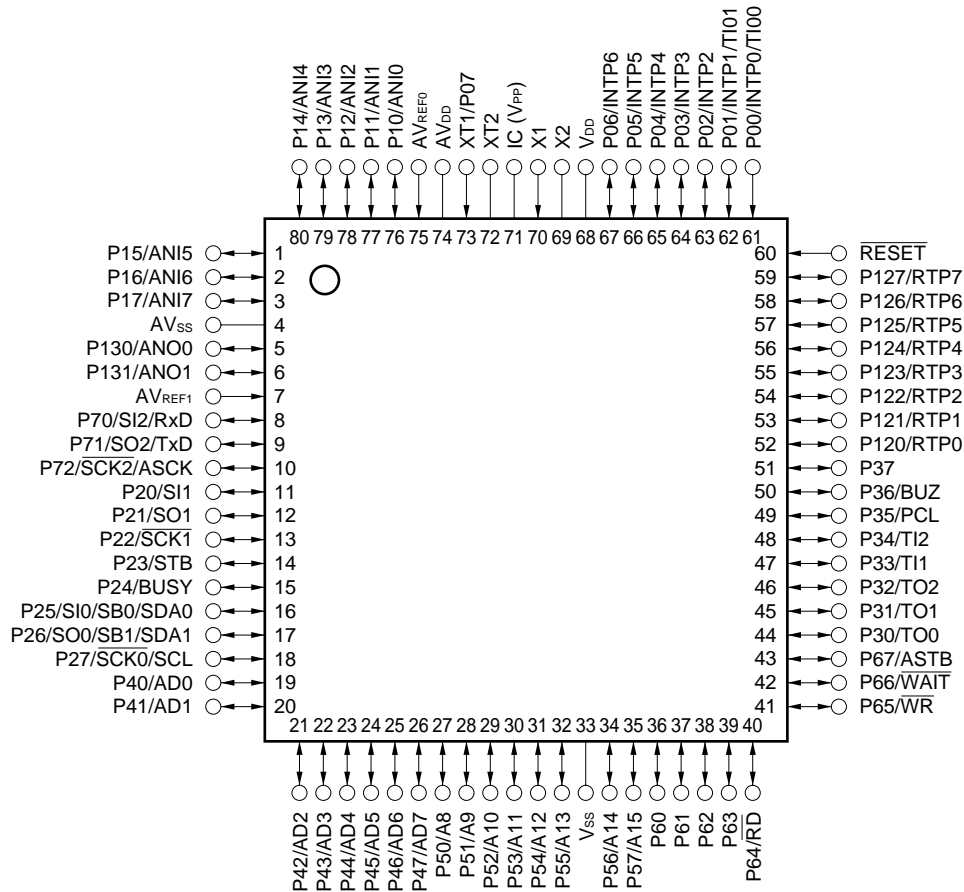
- **80-pin plastic QFP (14 × 14 mm, Resin thickness: 1.4 mm)**

μ PD78052YGC-xxx-8BT, 78053YGC-xxx-8BT, 78054YGC-xxx-8BT

μ PD78055YGC-xxx-8BT, 78056YGC-xxx-8BT, 78058YGC-xxx-8BT, 78P058YGC-8BT

- **80-pin ceramic WQFN (14 × 14 mm)**

μ PD78P058YKK-T



- Cautions**
1. Be sure to connect IC (Internally Connected) pin to V_{SS} directly.
 2. Connect AV_{DD} pin to V_{DD}.
 3. Connect AV_{SS} pin to V_{SS}.

Remark Pin connection in parentheses is intended for the μ PD78P058Y.

Pin Identifications

A8 to A15	: Address Bus	PCL	: Programmable Clock
AD0 to AD7	: Address/Data Bus	$\overline{\text{RESET}}$: Reset
ANI0 to ANI7	: Analog Input	$\overline{\text{RD}}$: Read Strobe
ANO0 to ANO7	: Analog Output	RTP0 to RTP7	: Real-Time Output Port
ASCK	: Asynchronous Serial Clock	RxD	: Receive Data
ASTB	: Address Strobe	SB0, SB1	: Serial Bus
AV _{DD}	: Analog Power Supply	$\overline{\text{SCK0}}$ to $\overline{\text{SCK1}}$: Serial Clock
AV _{REF0} , AV _{REF1}	: Analog Reference Voltage	SCL	: Serial Clock
AV _{SS}	: Analog Ground	SDA0, SDA1	: Serial Data
BUSY	: Busy	SI0, SI1	: Serial Input
BUZ	: Buzzer Clock	SO0, SO1	: Serial Output
IC	: Internally Connected	STB	: Strobe
INTP0 to INTP6	: Interrupt from Peripherals	TI1, TI2	: Timer Input
P00 to P07	: Port0	TI00 to TI01	: Timer Input
P10 to P17	: Port1	TO0 to TO2	: Timer Output
P20 to P27	: Port2	TxD	: Transmit Data
P30 to P37	: Port3	V _{DD}	: Power Supply
P40 to P47	: Port4	V _{PP}	: Programming Power Supply
P50 to P57	: Port5	V _{SS}	: Ground
P60 to P67	: Port6	$\overline{\text{WAIT}}$: Wait
P70 to P72	: Port7	$\overline{\text{WR}}$: Write Strobe
P120 to P127	: Port12	X1, X2	: Crystal (Main System Clock)
P130, P131	: Port13	XT1, XT2	: Crystal (Subsystem Clock)

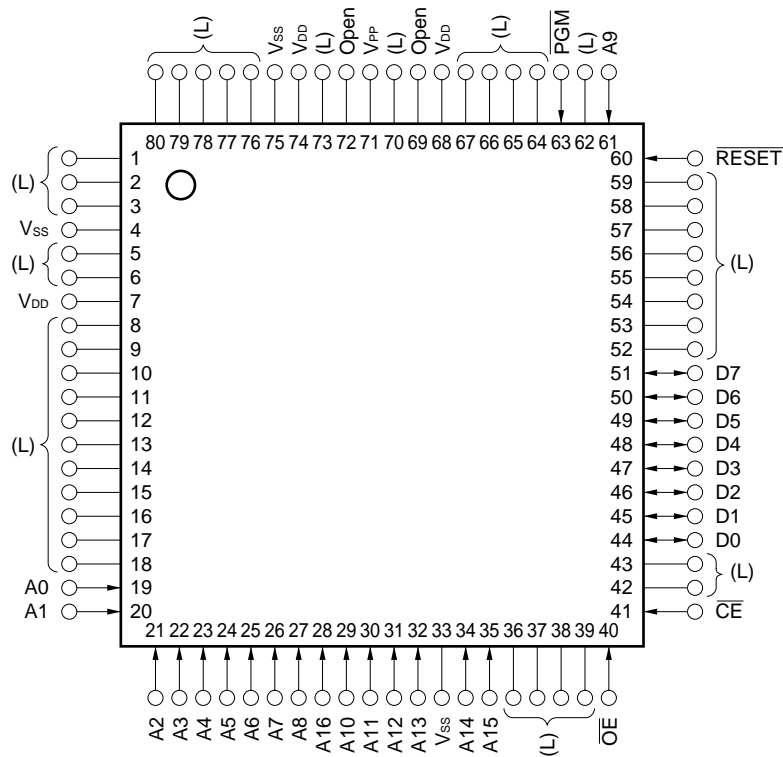
(2) PROM programming mode

- 80-pin plastic QFP (14 × 14 mm, Resin thickness: 1.4 mm)

μ PD78P058YGC-8BT

- 80-pin ceramic WQFN (14 × 14 mm)

μ PD78P058YKK-T



- Cautions**
1. (L) : Connect individually to V_{ss} via a pull-down resistor.
 2. V_{ss} : Connect to the ground.
 3. RESET : Set to the low level.
 4. Open : Leave this pin unconnected.

A0 to A16 : Address Bus

\overline{CE} : Chip Enable

D0 to D7 : Data Bus

\overline{OE} : Output Enable

\overline{PGM} : Program

\overline{RESET} : Reset

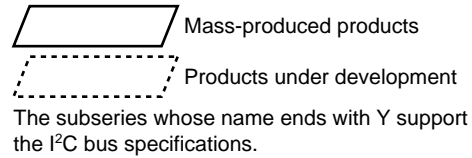
V_{DD} : Power Supply

V_{PP} : Programming Power Supply

V_{ss} : Ground

★ 2.6 78K/0 Series Expansion

The products in the 78K/0 Series are listed below. The names in boxes are subseries names.



Control		
100-pin	μ PD78075B	Reduced EMI noise version of μ PD78078
100-pin	μ PD78078	Added timers to μ PD78054 and enhanced external interface
100-pin	μ PD78070A	ROM-less version of μ PD78078
100-pin	μ PD78070AY	
100-pin	μ PD780018AY	Enhanced serial I/O of μ PD78078Y and functions are defined.
80-pin	μ PD780058	Enhanced serial I/O of μ PD78054, reduced EMI noise version
80-pin	μ PD780058Y	Note
80-pin	μ PD78058F	Reduced EMI noise version of μ PD78054
80-pin	μ PD78058FY	
80-pin	μ PD78054	Added UART and D/A to μ PD78014 and enhanced I/Os
80-pin	μ PD78054Y	
64-pin	μ PD780034	Enhanced A/D of μ PD780024
64-pin	μ PD780034Y	
64-pin	μ PD780024	Enhanced serial I/O of μ PD78018F
64-pin	μ PD780024Y	
64-pin	μ PD78014H	Reduced EMI noise version of μ PD78018F
64-pin	μ PD78018F	Low-voltage (1.8 V) version of μ PD78014 and enhanced ROM/RAM size options
64-pin	μ PD78018FY	
64-pin	μ PD78014	Added A/D and 16-bit timer to μ PD78002
64-pin	μ PD78014Y	
64-pin	μ PD780001	Added A/D to μ PD78002
64-pin	μ PD78002	Basic subseries for control applications
64-pin	μ PD78002Y	
42-/44-pin	μ PD78083	Equipped with UART and operates at low-voltage (1.8 V)
Inverter control		
64-pin	μ PD780988	Enhanced inverter control, timer, and SIO of μ PD780964, expanded ROM and RAM
64-pin	μ PD780964	Enhanced A/D of μ PD780924
64-pin	μ PD780924	Equipped with inverter control circuit and UART, reduced EMI noise version
FIP driving		
100-pin	μ PD780208	Enhanced I/O and FIP C/D of μ PD78044F, 53 display outputs
100-pin	μ PD780228	Enhanced I/O and FIP C/D of μ PD78044H, 48 display outputs
80-pin	μ PD78044H	Added N-ch open-drain I/O to μ PD78044F, 34 display outputs
80-pin	μ PD78044F	Basic subseries for driving FIPs, 34 display outputs
LCD driving		
100-pin	μ PD780308	Enhanced SIO of μ PD78064, expanded ROM and RAM
100-pin	μ PD780308Y	
100-pin	μ PD78064B	Reduced EMI noise version of μ PD78064
100-pin	μ PD78064	Basic subseries for driving LCDs, equipped with UART
100-pin	μ PD78064Y	
IEBus supported		
80-pin	μ PD78098B	Reduced EMI noise version of μ PD78098
80-pin	μ PD78098	Added IEBus controller to μ PD78054
Meter control		
80-pin	μ PD780973	Equipped with controller/driver for driving automobile meters

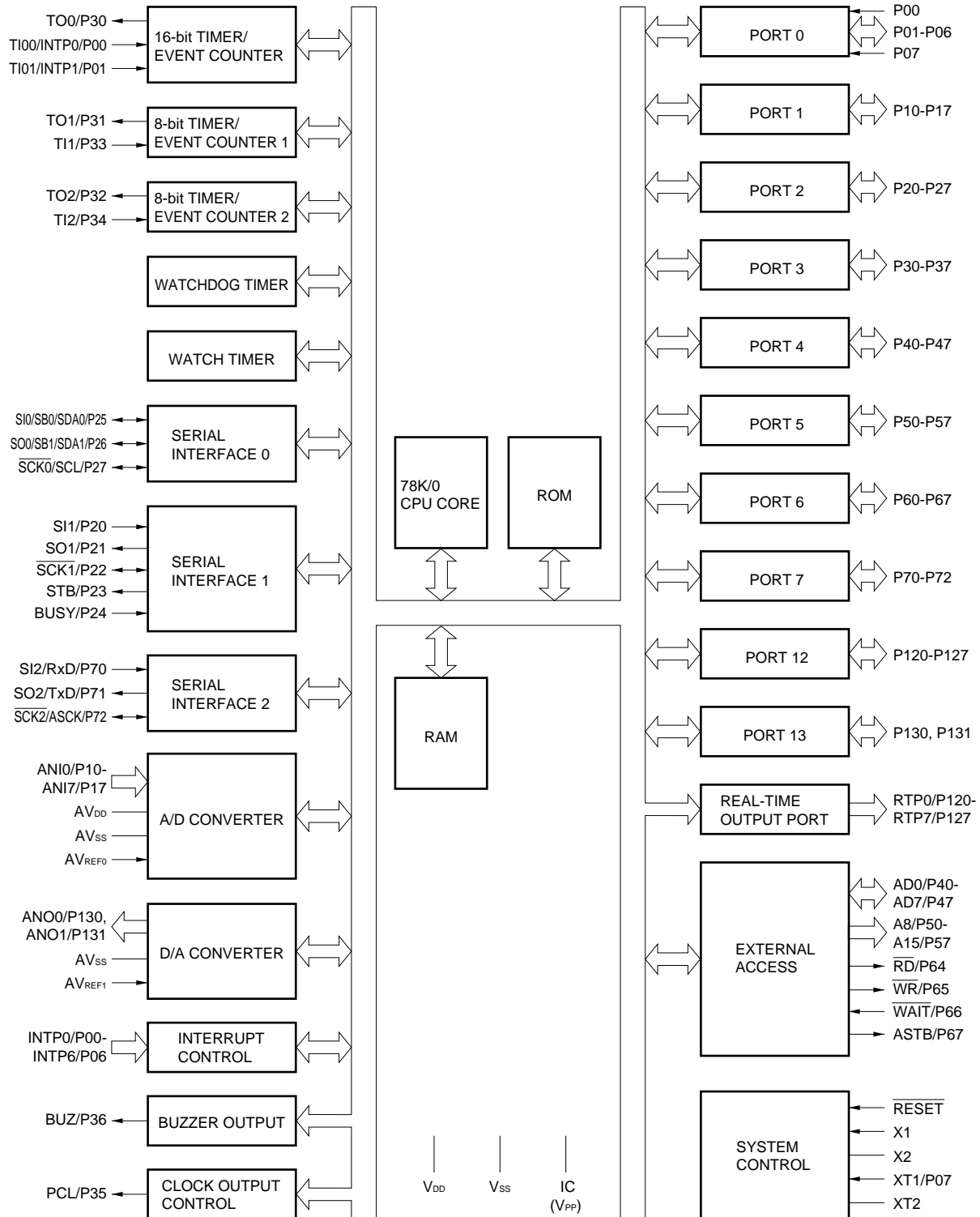
Note Planned

Major differences among Y subseries are tabulated below.

Subseries	Function	ROM Capacity	Configuration of Serial Interface	I/O	V _{DD} MIN.
Control	μ PD78078Y	48K to 60K	3-wire/2-wire/I ² C : 1 ch 3-wire with automatic transmit/receive function : 1 ch	88	1.8 V
	μ PD78070AY	—	3-wire/UART : 1 ch	61	2.7 V
	μ PD780018AY	48K to 60K	3-wire with automatic transmit/receive function : 1 ch Time division 3-wire : 1 ch I ² C bus (supports multi-master) : 1 ch	88	
	μ PD780058Y	24K to 60K	3-wire/2-wire/I ² C : 1 ch 3-wire with automatic transmit/receive function : 1 ch 3-wire/time division UART : 1 ch	68	1.8 V
	μ PD78058FY	48K to 60K	3-wire/2-wire/I ² C : 1 ch	69	2.7 V
	μ PD78054Y	16K to 60K	3-wire with automatic transmit/receive function : 1 ch 3-wire/UART : 1 ch		2.0 V
	μ PD780034Y	8K to 32K	UART : 1 ch 3-wire : 1 ch I ² C bus (supports multi-master) : 1 ch	51	1.8 V
	μ PD780024Y				
	μ PD78018FY	8K to 60K	3-wire/2-wire/I ² C : 1 ch 3-wire with automatic transmit/receive function : 1 ch	53	
	μ PD78014Y	8K to 32K	3-wire/2-wire/I ² C : 1 ch 3-wire with automatic transmit/receive function : 1 ch		2.7 V
μ PD78002Y	8K to 16K	3-wire/2-wire/SBI/I ² C : 1 ch			
LCD drive	μ PD780308Y	48K to 60K	3-wire/2-wire/I ² C : 1 ch 3-wire/time division UART : 1 ch 3-wire : 1 ch	57	2.0 V
	μ PD78064Y	16K to 32K	3-wire/2-wire/I ² C : 1 ch 3-wire/UART : 1 ch		

Remark The functions except serial interface are common with subseries without Y.

2.7 Block Diagram



Remarks 1. The internal ROM and RAM capacities depend on the product.

2. Pin connection in parentheses is intended for the μ PD78P058.

2.8 Outline of Function

Item		Part Number						
		μ PD78052Y	μ PD78053Y	μ PD78054Y	μ PD78055Y	μ PD78056Y	μ PD78058Y	μ PD78P058Y
Internal memory	ROM	Mask ROM						PROM
		16 Kbytes	24 Kbytes	32 Kbytes	40 Kbytes	48 Kbytes	60 Kbytes	60 Kbytes Note 1
	High-speed RAM	512 bytes	1024 bytes				1024 bytes Note 1	
	Buffer RAM	32 bytes						
	Expansion RAM	None					1024 bytes	1024 bytes Note 2
Memory space		64 Kbytes						
General register		8 bits \times 8 \times 4 banks						
Minimum instruction execution time	With main system clock selected	0.4 μ s/0.8 μ s/1.6 μ s/3.2 μ s/6.4 μ s/12.8 μ s (@ 5.0 MHz)						
	With subsystem clock selected	122 μ s (@ 32.768 kHz)						
Instruction set		<ul style="list-style-type: none"> • 16-bit operation • Multiply/divide (8 bits \times 8 bits, 16 bits \div 8 bits) • Bit manipulate (set, reset, test, and Boolean operation) • BCD adjust, etc. 						
I/O port		<ul style="list-style-type: none"> • Total : 69 • CMOS input : 2 • CMOS I/O : 63 • N-ch open-drain I/O : 4 						
A/D converter		8-bit resolution \times 8 channels						
D/A converter		8-bit resolution \times 2 channels						
Serial interface		<ul style="list-style-type: none"> • 3-wire serial I/O/2-wire serial I/O/I²C bus mode selection possible : 1 channel • 3-wire serial I/O mode (Max. 32-byte on-chip auto-transmit/receive) : 1 channel • 3-wire serial I/O/UART mode selectable : 1 channel 						
Timer		<ul style="list-style-type: none"> • 16-bit timer/event counter : 1 channel • 8-bit timer/event counter : 2 channels • Watch timer : 1 channel • Watchdog timer : 1 channel 						
Timer output		Three outputs: (14-bit PWM output enable: 1)						
Clock output		19.5 kHz, 39.1 kHz, 78.1 kHz, 156 kHz, 313 kHz, 625 kHz, 1.25 MHz, 2.5 MHz, 5.0 MHz (@ 5.0 MHz with main system clock) 32.768 kHz (@ 32.768 kHz with subsystem clock)						
Buzzer output		1.2 kHz, 2.4 kHz, 4.9 kHz, 9.8 kHz (@ 5.0 MHz with main system clock)						

- Notes**
1. The capacities of the internal PROM and the internal high-speed RAM can be changed using the memory switching register (IMS).
 2. The capacity of the internal expansion RAM can be changed using the internal expansion RAM size switching register (IXS).

Item		Part Number	μ PD78052Y	μ PD78053Y	μ PD78054Y	μ PD78055Y	μ PD78056Y	μ PD78058Y	μ PD78P058Y
		Vectored interrupt source		Maskable	Internal: 13 External: 7				
		Non-maskable	Internal: 1						
		Software	1						
Test input			Internal: 1 External: 1						
Supply voltage			$V_{DD} = 2.0$ to 6.0 V						
Operating ambient temperature			$T_A = -40$ to $+85$ °C						
Package			<ul style="list-style-type: none"> • 80-pin plastic QFP (14 × 14 mm, Resin thickness: 2.7 mm) • 80-pin plastic QFP (14 × 14 mm, Resin thickness: 1.4 mm) • 80-pin ceramic WQFN (14 × 14 mm) (μPD78P058 only) 						

2.9 Mask Options

The mask ROM versions (μ PD78052Y, 78053Y, 78054Y, 78055Y, 78056Y, 78058Y) provide pull-up resistor mask options which allow users to specify whether to connect a pull-up resistor to a specific port pin when the user places an order for the device production. Using this mask option when pull-up resistors are required reduces the number of components to add to the device, resulting in board space saving.

The mask options provided in the μ PD78054Y subseries are shown in Table 2-1.

Table 2-1. Mask Options of Mask ROM Versions

Pin names	Mask options
P60 to P63	Pull-up resistor connection can be specified in 1-bit units.

CHAPTER 3 PIN FUNCTION (μ PD78054 Subseries)

3.1 Pin Function List

3.1.1 Normal operating mode pins

(1) Port pins (1/3)

Pin Name	Input/Output	Function		After Reset	Alternate Function	
P00	Input	Port 0. 8-bit input/output port.	Input only	Input	INTP0/TI00	
P01	Input/ output		When used as an input port, an on-chip pull-up resistor can be used by software.	Input/output mode can be specified in 1-bit units.	Input	INTP1/TI01
P02						INTP2
P03						INTP3
P04						INTP4
P05						INTP5
P06						INTP6
P07 ^{Note1}	Input		Input only		Input	XT1
P10 to P17	Input/ output	Port 1. 8-bit input/output port. Input/output mode can be specified in 1-bit units. When used as input port, an on-chip pull-up resistor can be used by software ^{Note2} .		Input	ANI0 to ANI7	
P20	Input/ output	Port 2. 8-bit input/output port. Input/output mode can be specified in 1-bit units. When used as an input port, an on-chip pull-up resistor can be used by software.		Input	SI1	
P21					SO1	
P22					SCK1	
P23					STB	
P24					BUSY	
P25					SI0/SB0	
P26					SO0/SB1	
P27					SCK0	

- Notes**
1. When the P07/XT1 pin is used as an input port, set the bit 6 (FRC) of the processor clock control register (PCC) to 1 (do not use the feedback resistor internal to the subsystem clock oscillator).
 2. When pins P10/ANI0 to P17/ANI7 are used as an analog input of the A/D converter, set port 1 to input mode. The on-chip pull-up resistor will automatically be disabled.

(1) Port pins (2/3)

Pin Name	Input/Output	Function		After Reset	Alternate Function	
P30	Input/ output	Port 3. 8-bit input/output port. Input/output mode can be specified in 1-bit units. When used as an input port, an on-chip pull-up resistor can be used by software.		Input	TO0	
P31					TO1	
P32					TO2	
P33					TI1	
P34					TI2	
P35					PCL	
P36					BUZ	
P37					—	
P40 to P47	Input/ output	Port 4. 8-bit input/output port. Input/output mode can be specified in 8-bit units. When used as an input port, an on-chip pull-up resistor can be used by software. Test input flag (KRIF) is set to 1 by falling edge detection.		Input	AD0 to AD7	
P50 to P57	Input/ output	Port 5. 8-bit input/output port. LED can be driven directly. Input/output mode can be specified in 1-bit units. When used as an input port, an on-chip pull-up resistor can be used by software.		Input	A8 to A15	
P60	Input/ output	Port 6. 8-bit input/output port. Input/output mode can be specified in 1-bit units.		Input	—	
P61					N-ch open-drain input/output port. On-chip pull-up resistor can be specified by mask option. (Mask ROM version only). LEDs can be driven directly.	
P62						When used as an input port, an on-chip pull-up resistor can be used by software.
P63					\overline{RD}	
P64					\overline{WR}	
P65					\overline{WAIT}	
P66					ASTB	
P67						
P70	Input/ output	Port 7. 3-bit input/output port. Input/output mode can be specified in 1-bit units. When used as an input port, an on-chip pull-up resistor can be used by software.		Input	$\overline{SI2/RxD}$	
P71					$\overline{SO2/TxD}$	
P72					$\overline{SCK2/ASCK}$	

(1) Port pins (3/3)

Pin Name	Input/Output	Function	After Reset	Alternate Function
P120 to P127	Input/ output	Port 12. 8-bit input/output port. Input/output mode can be specified in 1-bit units. When used as an input port, an on-chip pull-up resistor can be used by software.	Input	RTP0 to RTP7
P130 to P131	Input/ output	Port 13. 2-bit input/output port. Input/output mode can be specified in 1-bit units. When used as an input port, an on-chip pull-up resistor can be used by software.	Input	ANO0 to ANO1

(2) Pins other than port pins (1/2)

Pin Name	Input/Output	Function	After Reset	Alternate Function
INTP0	Input	External interrupt request inputs with specifiable valid edges (rising edge, falling edge, both rising and falling edges).	Input	P00/TI00
INTP1				P01/TI01
INTP2				P02
INTP3				P03
INTP4				P04
INTP5				P05
INTP6				P06
SI0	Input	Serial interface serial data input	Input	P25/SB0
SI1				P20
SI2				P70/RxD
SO0	Output	Serial interface serial data output	Input	P26/SB1
SO1				P21
SO2				P71/TxD
SB0	Input/ output	Serial interface serial data input/output	Input	P25/SI0
SB1				P26/SO0
$\overline{\text{SCK0}}$	Input/ output	Serial interface serial clock input/output	Input	P27
$\overline{\text{SCK1}}$				P22
$\overline{\text{SCK2}}$				P72/ASCK
STB	Output	Serial interface automatic transmit/receive strobe output	Input	P23
BUSY	Input	Serial interface automatic transmit/receive busy input	Input	P24
RxD	Input	Asynchronous serial interface serial data input	Input	P70/SI2
TxD	Output	Asynchronous serial interface serial data output	Input	P71/SO2
ASCK	Input	Asynchronous serial interface serial clock input	Input	P72/ $\overline{\text{SCK2}}$
TI00	Input	External count clock input to 16-bit timer (TM0)	Input	P00/INTP0
TI01		Capture trigger signal input to capture register (CR00)		P01/INTP1
TI1		External count clock input to 8-bit timer (TM1)		P33
TI2		External count clock input to 8-bit timer (TM2)		P34
TO0	Output	16-bit timer (TM0) output (also used for 14-bit PWM output)	Input	P30
TO1		8-bit timer (TM1) output		P31
TO2		8-bit timer (TM2) output		P32
PCL	Output	Clock output (for main system clock and subsystem clock trimming)	Input	P35
BUZ	Output	Buzzer output	Input	P36
RTP0 to RTP7	Output	Real-time output port outputting data in synchronization with trigger	Input	P120 to P127

(2) Pins other than port pins (2/2)

Pin Name	Input/Output	Function	After Reset	Alternate Function
AD0 to AD7	Input/Output	Low-order address/data bus when expanding external memory	Input	P40 to P47
A8 to A15	Output	High-order address bus when expanding external memory	Input	P50 to P57
$\overline{\text{RD}}$	Output	Strobe signal output for read operation from external memory	Input	P64
$\overline{\text{WR}}$		Strobe signal output for write operation to external memory		P65
$\overline{\text{WAIT}}$	Input	Wait insertion when accessing external memory	Input	P66
ASTB	Output	Strobe output externally latching address information output to ports 4, 5 to access external memory	Input	P67
ANI0 to ANI7	Input	A/D converter analog input	Input	P10 to P17
ANO0, ANO1	Output	D/A converter analog output	Input	P130, P131
AV_{REF0}	Input	A/D converter reference voltage input	—	—
AV_{REF1}	Input	D/A converter reference voltage input	—	—
AV_{DD}	—	A/D converter analog power supply. Connect to V_{DD} .	—	—
AV_{SS}	—	A/D and D/A converter ground potential. Connect to V_{SS} .	—	—
$\overline{\text{RESET}}$	Input	System reset input	—	—
X1	Input	Crystal connection for main system clock oscillation	—	—
X2	—		—	—
XT1	Input	Crystal connection for subsystem clock oscillation	Input	P07
XT2	—		—	—
V_{DD}	—	Positive power supply	—	—
V_{PP}	—	High-voltage application for program write/verify. Directly connect to V_{SS} in normal operating mode.	—	—
V_{SS}	—	Ground potential	—	—
IC	—	Internally connected. Directly connect to the V_{SS} pin.	—	—

3.1.2 PROM programming mode pins (PROM versions only)

Pin Name	Input/Output	Function
$\overline{\text{RESET}}$	Input	PROM programming mode setting. When +5 V or +12.5 V is applied to the V_{PP} pin or a low level voltage is applied to the $\overline{\text{RESET}}$ pin, the PROM programming mode is set.
V_{PP}	Input	High-voltage application for PROM programming mode setting and program write/verify.
A0 to A16	Input	Address bus
D0 to D7	Input/output	Data bus
$\overline{\text{CE}}$	Input	PROM enable input/program pulse input
$\overline{\text{OE}}$	Input	Read strobe input to PROM
$\overline{\text{PGM}}$	Input	Program/program inhibit input in PROM programming mode
V_{DD}	—	Positive power supply
V_{SS}	—	Ground potential

3.2 Description of Pin Functions

3.2.1 P00 to P07 (Port 0)

These are 8-bit input/output ports. Besides serving as input/output ports, they function as an external interrupt request input, an external count clock input to the timer, a capture trigger signal input, and crystal connection for subsystem oscillation.

The following operating modes can be specified in 1-bit units.

(1) Port mode

P00 and P07 function as input-only ports and P01 to P06 function as input/output ports.

P01 to P06 can be specified for input or output ports in 1-bit units with a port mode register 0 (PM0). When they are used as input ports, on-chip pull-up resistors can be used to them by defining the pull-up resistor option register L (PUOL).

(2) Control mode

In this mode, these ports function as an external interrupt request input, an external count clock input to the timer, and crystal connection for subsystem clock oscillation.

(a) INTP0 to INTP6

INTP0 to INTP6 are external interrupt request input pins which can specify valid edges (rising edge, falling edge, and both rising and falling edges). INTP0 or INTP1 becomes a 16-bit timer/event counter capture trigger signal input pin with a valid edge input.

(b) TI00

Pin for external count clock input to 16-bit timer/event counter

(c) TI01

Pin for capture trigger signal to capture register (CR00) of 16-bit timer/event counter

(d) XT1

Crystal connect pin for subsystem clock oscillation

3.2.2 P10 to P17 (Port 1)

These are 8-bit input/output ports. Besides serving as input/output ports, they function as an A/D converter analog input.

The following operating modes can be specified in 1-bit units.

(1) Port mode

These ports function as 8-bit input/output ports.

They can be specified in 1-bit units as input or output ports with a port mode register 1 (PM1). If used as input ports, on-chip pull-up resistors can be used to these ports by defining the pull-up resistor option register L (PUOL).

(2) Control mode

These ports function as A/D converter analog input pins (ANI0 to ANI7). The on-chip pull-up resistor is automatically disabled when the pins specified for analog input.

3.2.3 P20 to P27 (Port 2)

These are 8-bit input/output ports. Besides serving as input/output ports, they function as data input/output to/from the serial interface, clock input/output, automatic transmit/receive busy input, and strobe output functions.

The following operating modes can be specified in 1-bit units.

(1) Port mode

These ports function as 8-bit input/output ports. They can be specified in 1-bit units as input or output ports with port mode register 2 (PM2). When they are used as input ports, on-chip pull-up resistors can be used to them by defining the pull-up resistor option register L (PUOL).

(2) Control mode

These ports function as serial interface data input/output, clock input/output, automatic transmit/receive busy input, and strobe output functions.

(a) SI0, SI1, SO0, SO1

Serial interface serial data input/output pins

(b) $\overline{\text{SCK0}}$ and $\overline{\text{SCK1}}$

Serial interface serial clock input/output pins

(c) SB0 and SB1

NEC standard serial bus interface input/output pins

(d) BUSY

Serial interface automatic transmit/receive busy input pins

(e) STB

Serial interface automatic transmit/receive strobe output pins

Caution When this port is used as a serial interface, the I/O and output latches must be set according to the function the user requires. For the setting, refer to Figure 16-4 “Serial Operation Mode Register 0 Format” and Figure 18-3 “Serial Operation Mode Register 1 Format.”

3.2.4 P30 to P37 (Port 3)

These are 8-bit input/output ports. Beside serving as input/output ports, they function as timer input/output, clock output and buzzer output.

The following operating modes can be specified in 1-bit units.

(1) Port mode

These ports function as 8-bit input/output ports. They can be specified in 1-bit units as input or output ports with port mode register 3 (PM3). When they are used as input ports, on-chip pull-up resistors can be used by defining the pull-up resistor option register L (PUOL).

(2) Control mode

These ports function as timer input/output, clock output, and buzzer output.

(a) TI1 and TI2

Pin for external count clock input to the 8-bit timer/event counter.

(b) TO0 to TO2

Timer output pins.

(c) PCL

Clock output pin.

(d) BUZ

Buzzer output pin.

3.2.5 P40 to P47 (Port 4)

These are 8-bit input/output ports. Besides serving as input/output ports, they function as an address/data bus. The test input flag (KRIF) can be set to 1 by detecting a falling edge. The following operating mode can be specified in 8-bit units.

(1) Port mode

These ports function as 8-bit input/output ports. They can be specified in 8-bit units for input or output ports by using the memory expansion mode register (MM). When they are used as input ports, on-chip pull-up resistors can be used by defining the pull-up resistor option register L (PUOL).

(2) Control mode

These ports function as low-order address/data bus pins (AD0 to AD7) in external memory expansion mode. When pins are used as an address/data bus, the on-chip pull-up resistor is automatically disabled.

3.2.6 P50 to P57 (Port 5)

These are 8-bit input/output ports. Besides serving as input/output ports, they function as an address bus. Port 5 can drive LEDs directly. The following operating modes can be specified in 1-bit units.

(1) Port mode

These ports function as 8-bit input/output ports. They can be specified in 1-bit units as input/output ports with port mode register 5 (PM5). When they are used as input ports, on-chip pull-up resistors can be used by defining the pull-up resistor option register L (PUOL).

(2) Control mode

These ports function as high-order address bus pins (A8 to A15) in external memory expansion mode. When pins are used as an address bus, the on-chip pull-up resistor is automatically disabled.

3.2.7 P60 to P67 (Port 6)

These are 8-bit input/output ports. Besides serving as input/output ports, they are used for control in external memory expansion mode. P60 to P63 can drive LEDs directly. The following operating modes can be specified in 1-bit units.

(1) Port mode

These ports function as 8-bit input/output ports. They can be specified in 1-bit units as input or output ports with port mode register 6 (PM6). P60 to P63 are N-ch open drain outputs. Mask ROM version can contain pull-up resistors with the mask option. When P64 to P67 are used as input ports, on-chip pull-up resistors can be used by defining the pull-up resistor option register L (PUOL).

(2) Control mode

These ports function as control signal output pins (\overline{RD} , \overline{WR} , \overline{WAIT} , ASTB) in external memory expansion mode. When a pin is used as a control signal output, the on-chip pull-up resistor is automatically disabled.

Caution When external wait is not used in external memory expansion mode, P66 can be used as an input/output port.

3.2.8 P70 to P72 (Port 7)

This is a 3-bit input/output port. In addition to its use as an input/output port, it also has serial interface data input/output and clock input/output functions.

The following operating modes can be specified in 1-bit units.

(1) Port mode

Port 7 functions as a 3-bit input/output port. 1-bit-units specification as an input port or output port is possible by means of port mode register 7 (PM7). When used as input ports, on-chip pull-up resistors can be used by defining the pull-up resistor option register L (PUOL).

(2) Control mode

Port 7 functions as serial interface data input/output and clock input/output.

(a) SI2, SO2

Serial interface serial data input/output pins

(b) $\overline{\text{SCK2}}$

Serial interface serial clock input/output pin.

(c) RxD, TxD

Asynchronous serial interface serial data input/output pins.

(d) ASCK

Asynchronous serial interface serial clock input/output pin.

Caution When this port is used as a serial interface, the I/O and output latches must be set according to the function the user requires.

For the setting, see the operation mode setting list in Table 19-2 “Serial Interface Channel 2”.

3.2.9 P120 to P127 (Port 12)

These are 8-bit input/output ports. Besides serving as input/output ports, they function as a real-time output port. The following operating modes can be specified in 1-bit units.

(1) Port mode

These ports function as 8-bit input/output ports. They can be specified in 1-bit units as input or output ports with port mode register 12 (PM12). When they are used as input ports, on-chip pull-up resistors can be used by defining the pull-up resistor option register H (PUOH).

(2) Control mode

These ports function as real-time output ports (RTP0 to RTP7) outputting data in synchronization with a trigger.

3.2.10 P130 and P131 (Port 13)

These are 2-bit input/output ports. Besides serving as input/output ports, they are used for D/A converter analog output.

The following operating modes can be specified in 1-bit units.

(1) Port mode

These ports function as 2-bit input/output ports. They can be specified in 1-bit units as input or output ports with port mode register 13 (PM13). When they are used as input ports, on-chip pull-up resistors can be used by defining the pull-up resistor option register H (PUOH).

(2) Control mode

These ports allow D/A converter analog output (ANO0 and ANO1).

Caution When only either one of the D/A converter channels is used with $AV_{REF1} < V_{DD}$, the other pins that are not used as analog outputs must be set as follows:

- Set PM13x bit of the port mode register 13 (PM13) to 1 (input mode) and connect the pin to V_{SS} .
- Set PM13x bit of the port mode register 13 (PM13) to 0 (output mode) and the output latch to 0, to output low level from the pin.

3.2.11 AV_{REF0}

A/D converter reference voltage input pin.

When A/D converter is not used, connect this pin to V_{SS} .

3.2.12 AV_{REF1}

D/A converter reference voltage input pin.

When D/A converter is not used, connect this pin to V_{DD} .

3.2.13 AV_{DD}

Analog power supply pin of A/D converter. Always use the same voltage as that of the V_{DD} pin even when A/D converter is not used.

3.2.14 AV_{SS}

This is a ground voltage pin of A/D converter and D/A converter. Always use the same voltage as that of the V_{SS} pin even when neither A/D nor D/A converter is used.

3.2.15 RESET

This is a low-level active system reset input pin.

3.2.16 X1 and X2

Crystal resonator connect pins for main system clock oscillation. For external clock supply, input it to X1 and its inverted signal to X2.

3.2.17 XT1 and XT2

Crystal resonator connect pins for subsystem clock oscillation.

For external clock supply, input it to XT1 and its inverted signal to XT2.

3.2.18 V_{DD}

Positive power supply pin

3.2.19 V_{SS}

Ground potential pin

3.2.20 V_{PP} (PROM versions only)

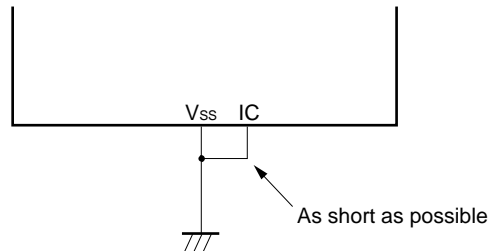
High-voltage apply pin for PROM programming mode setting and program write/verify. Directly connect to V_{SS} in the normal operating mode.

3.2.21 IC (Mask ROM version only)

The IC (Internally Connected) pin is provided to set the test mode to check the μ PD78054 Subseries before shipment. Directly connect this pin to the V_{SS} with the shortest possible wire in the normal operating mode.

When a voltage difference is produced between the IC pin and V_{SS} pin because the wiring between those two pins is too long or an external noise is input to the IC pin, the user's program may not run normally.

- Directly connect IC pins to V_{SS} pins.



3.3 Input/output Circuits and Recommended Connection of Unused Pins

Table 3-1 shows the input/output circuit types of pins and the recommended conditions for unused pins. Refer to Figure 3-1 for the configuration of the input/output circuit of each type.

Table 3-1. Pin Input/Output Circuit Types (1/2)

Pin Name	Input/Output Circuit Type	Input/Output	Recommended Connection of Unused Pins		
P00/INTP0/TI00	2	Input	Connect to V_{SS} .		
P01/INTP1/TI01	8-A	Input/Output	Individually connect to V_{SS} via a resistor.		
P02/INTP2					
P03/INTP3					
P04/INTP4					
P05/INTP5					
P06/INTP6					
P07/XT1	16	Input	Connect to V_{DD} .		
P10/ANI0 to P17/ANI7	11	Input/Output	Individually connect to V_{DD} or V_{SS} via a resistor.		
P20/SI1	8-A				
P21/SO1	5-A				
P22/SCK1	8-A				
P23/STB	5-A				
P24/BUSY	8-A				
P25/SI0/SB0	10-A				
P26/SO0/SB1					
P27/SCK0					
P30/TO0	5-A				
P31/TO1					
P32/TO2					
P33/TI1	8-A				
P34/TI2					
P35/PCL	5-A				
P36/BUZ					
P37					
P40/AD0 to P47/AD7	5-E			Input/Output	Individually connect to V_{DD} via a resistor.
P50/A8 to P57/A15	5-A			Input/output	Individually connect to V_{DD} or V_{SS} via a resistor.

Table 3-1. Pin Input/Output Circuit Types (2/2)

Pin Name	Input/Output Circuit Type	Input/Output	Recommended Connection of Unused Pins
P60 to P63 (Mask ROM version)	13-B	Input/output	Individually connect to V_{DD} via a resistor.
P60 to P63 (PROM version)	13-D		
P64/ \overline{RD}	5-A	Input/output	Individually connect to V_{DD} or V_{SS} via a resistor.
P65/ \overline{WR}			
P66/ \overline{WAIT}			
P67/ \overline{ASTB}			
P70/SI2/RxD	8-A	Input/output	Individually connect to V_{DD} or V_{SS} via a resistor.
P71/SO2/TxD	5-A		
P72/ $\overline{SCK2}$ / \overline{ASCK}	8-A		
P120/RTP0 to P127/RTP7	5-A		
P130/ANO0, P131/ANO1	12-A	Input/output	Individually connect to V_{SS} via a resistor.
\overline{RESET}	2	Input	—
XT2	16	—	Leave open.
AV_{REF0}	—		Connect to V_{SS} .
AV_{REF1}			Connect to V_{DD} .
AV_{DD}			Connect to V_{SS} .
AV_{SS}			
IC (Mask ROM version)			Directly connect to V_{SS} .
V_{PP} (PROM version)			

Figure 3-1. Pin Input/Output Circuit of List (1/2)

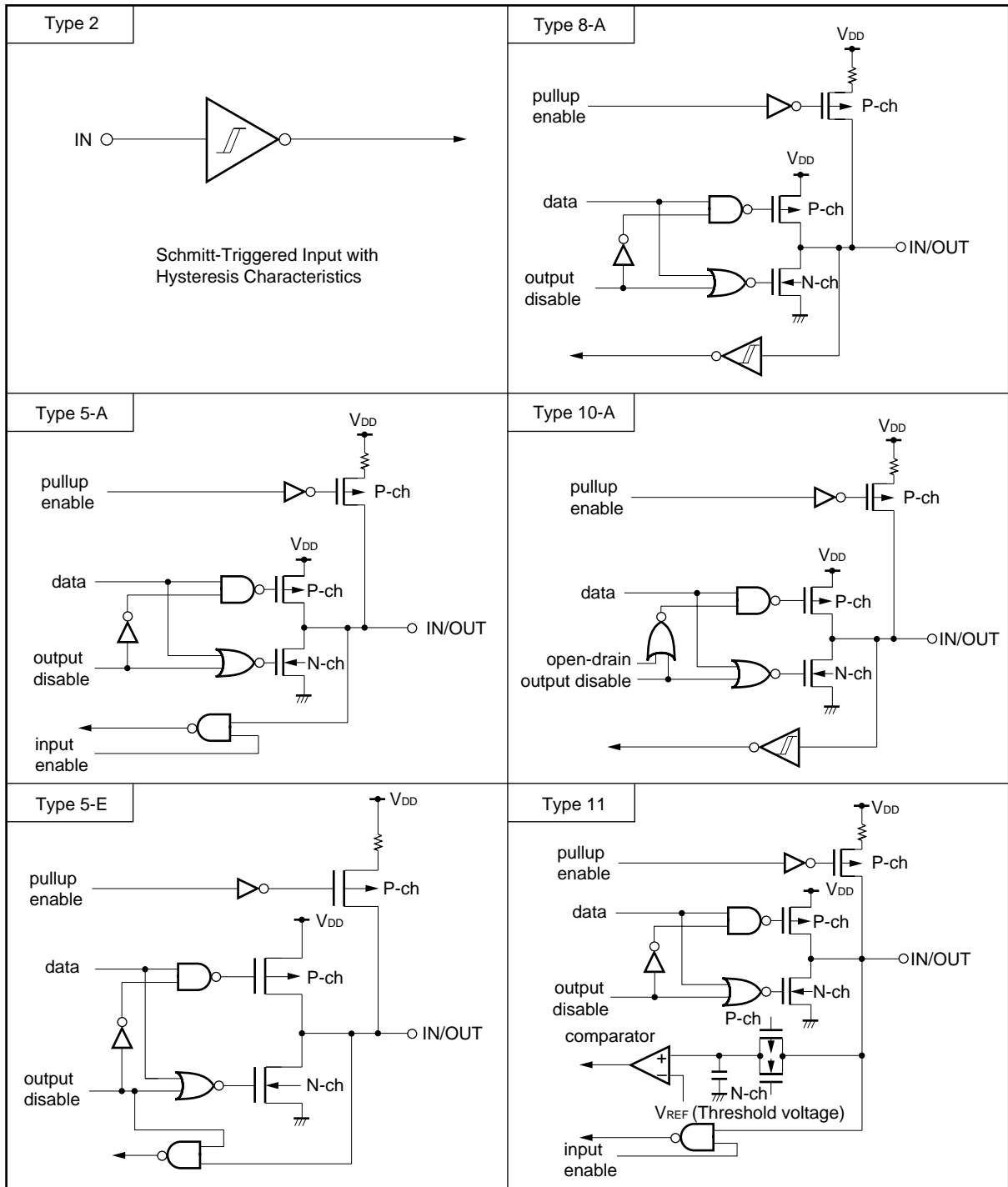
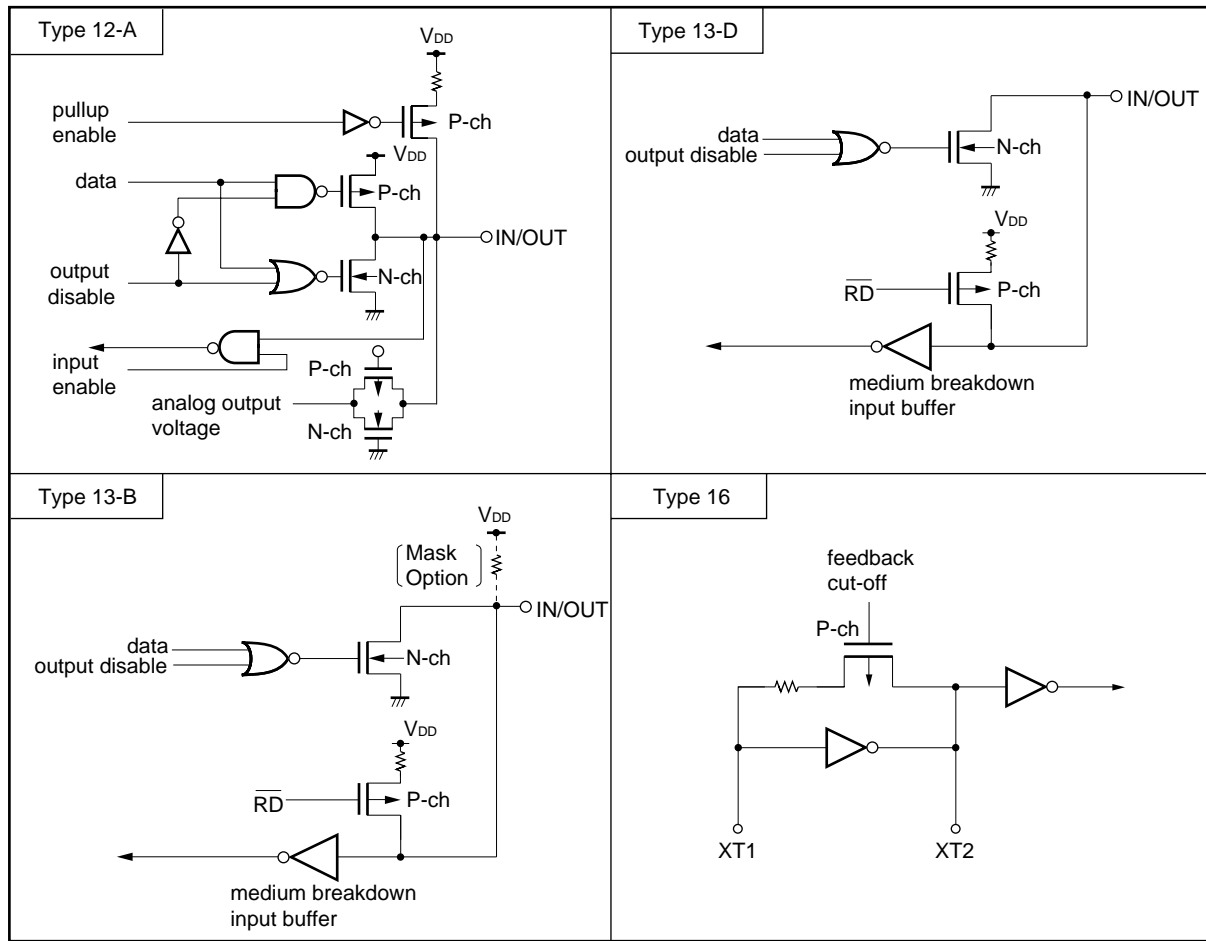


Figure 3-1. Pin Input/Output Circuit of List (2/2)



CHAPTER 4 PIN FUNCTION (μ PD78054Y Subseries)

4.1 Pin Function List

4.1.1 Normal operating mode pins

(1) Port pins (1/3)

Pin Name	Input/Output	Function		After Reset	Alternate Function	
P00	Input	Port 0. 8-bit input/output port.	Input only	Input	INTP0/TI00	
P01	Input/ output		When used as an input port, an on-chip pull-up resistor can be used by software.	Input/output mode can be specified in 1-bit units.	Input	INTP1/TI01
P02						INTP2
P03						INTP3
P04						INTP4
P05						INTP5
P06						INTP6
P07 ^{Note1}	Input		Input only	Input	XT1	
P10 to P17	Input/ output	Port 1. 8-bit input/output port. Input/output mode can be specified in 1-bit units. When used as input port, an on-chip pull-up resistor can be used by software ^{Note2} .		Input	ANI0 to ANI7	
P20	Input/ output	Port 2. 8-bit input/output port. Input/output mode can be specified in 1-bit units. When used as an input port, an on-chip pull-up resistor can be used by software.		Input	SI1	
P21					SO1	
P22					SCK1	
P23					STB	
P24					BUSY	
P25					SI0/SB0/SDA0	
P26					SO0/SB1/SDA1	
P27					SCK0/SCL	

- Notes**
1. When the P07/XT1 pin is used as an input port, set the bit 6 (FRC) of the processor clock control register (PCC) to 1 (do not use the feedback resistor internal to the subsystem clock oscillator).
 2. When pins P10/ANI0 to P17/ANI7 are used as an analog input of the A/D converter, set port 1 to input mode. The on-chip pull-up resistor will automatically be disabled.

(1) Port pins (2/3)

Pin Name	Input/Output	Function		After Reset	Alternate Function	
P30	Input/ output	Port 3. 8-bit input/output port. Input/output mode can be specified in 1-bit units. When used as an input port, an on-chip pull-up resistor can be used by software.		Input	TO0	
P31					TO1	
P32					TO2	
P33					TI1	
P34					TI2	
P35					PCL	
P36					BUZ	
P37					—	
P40 to P47	Input/ output	Port 4. 8-bit input/output port. Input/output mode can be specified in 8-bit units. When used as an input port, an on-chip pull-up resistor can be used by software. Test input flag (KRIF) is set to 1 by falling edge detection.		Input	AD0 to AD7	
P50 to P57	Input/ output	Port 5. 8-bit input/output port. LED can be driven directly. Input/output mode can be specified in 1-bit units. When used as an input port, an on-chip pull-up resistor can be used by software.		Input	A8 to A15	
P60	Input/ output	Port 6. 8-bit input/output port. Input/output mode can be specified in 1-bit units.		Input	—	
P61					N-ch open drain input/output port. On-chip pull-up resistor can be specified by mask option. (Mask ROM version only). LEDs can be driven directly.	
P62						When used as an input port, an on-chip pull-up resistor can be used by software.
P63					\overline{RD}	
P64					\overline{WR}	
P65					\overline{WAIT}	
P66					ASTB	
P67						
P70	Input/ output	Port 7. 3-bit input/output port. Input/output mode can be specified in 1-bit units. When used as an input port, an on-chip pull-up resistor can be used by software.		Input	SI2/RxD	
P71					SO2/TxD	
P72					$\overline{SCK2/ASCK}$	

(1) Port pins (3/3)

Pin Name	Input/Output	Function	After Reset	Alternate Function
P120 to P127	Input/ output	Port 12. 8-bit input/output port. Input/output mode can be specified in 1-bit units. When used as an input port, an on-chip pull-up resistor can be used by software.	Input	RTP0 to RTP7
P130 to P131	Input/ output	Port 13. 2-bit input/output port. Input/output mode can be specified in 1-bit units. When used as an input port, an on-chip pull-up resistor can be used by software.	Input	ANO0 to ANO1

(2) Pins other than port pins (1/2)

Pin Name	Input/Output	Function	After Reset	Alternate Function
INTP0	Input	External interrupt request inputs with specifiable valid edges (rising edge, falling edge, both rising and falling edges).	Input	P00/TI00
INTP1				P01/TI01
INTP2				P02
INTP3				P03
INTP4				P04
INTP5				P05
INTP6				P06
SI0	Input	Serial interface serial data input	Input	P25/SB0/SDA0
SI1				P20
SI2				P70/RxD
SO0	Output	Serial interface serial data output	Input	P26/SB1/SDA1
SO1				P21
SO2				P71/TxD
SB0	Input/ output	Serial interface serial data input/output	Input	P25/SI0/SDA0
SB1				P26/SO0/SDA1
SDA0				P25/SI0/SB0
SDA1				P26/SO0/SB1
$\overline{\text{SCK0}}$	Input/ output	Serial interface serial clock input/output	Input	P27/SCL
$\overline{\text{SCK1}}$				P22
$\overline{\text{SCK2}}$				P72/ASCK
SCL				P27/ $\overline{\text{SCK0}}$
STB	Output	Serial interface automatic transmit/receive strobe output	Input	P23
BUSY	Input	Serial interface automatic transmit/receive busy input	Input	P24
RxD	Input	Asynchronous serial interface serial data input	Input	P70/SI2
TxD	Output	Asynchronous serial interface serial data output	Input	P71/ $\overline{\text{SO2}}$
ASCK	Input	Asynchronous serial interface serial clock input	Input	P72/SCK2
TI00	Input	External count clock input to 16-bit timer (TM0)	Input	P00/INTP0
TI01		Capture trigger signal input to capture register (CR00)		P01/INTP1
TI1		External count clock input to 8-bit timer (TM1)		P33
TI2		External count clock input to 8-bit timer (TM2)		P34
TO0	Output	16-bit timer (TM0) output (also used for 14-bit PWM output)	Input	P30
TO1		8-bit timer (TM1) output		P31
TO2		8-bit timer (TM2) output		P32
PCL	Output	Clock output (for main system clock and subsystem clock trimming)	Input	P35
BUZ	Output	Buzzer output	Input	P36
RTP0 to RTP7	Output	Real-time output port outputting data in synchronization with trigger	Input	P120 to P127

(2) Pins other than port pins (2/2)

Pin Name	Input/Output	Function	After Reset	Alternate Function
AD0 to AD7	Input/Output	Low-order address/data bus when expanding external memory	Input	P40 to P47
A8 to A15	Output	High-order address bus when expanding external memory	Input	P50 to P57
\overline{RD}	Output	Strobe signal output for read operation from external memory	Input	P64
\overline{WR}		Strobe signal output for write operation to external memory		P65
\overline{WAIT}	Input	Wait insertion when accessing external memory	Input	P66
ASTB	Output	Strobe output externally latching address information output to ports 4, 5 to access external memory	Input	P67
ANI0 to ANI7	Input	A/D converter analog input	Input	P10 to P17
ANO0, ANO1	Output	D/A converter analog output	Input	P130, P131
AV _{REF0}	Input	A/D converter reference voltage input	—	—
AV _{REF1}	Input	D/A converter reference voltage input	—	—
AV _{DD}	—	A/D converter analog power supply. Connect to V _{DD} .	—	—
AV _{SS}	—	A/D and D/A converter ground potential. Connect to V _{SS} .	—	—
\overline{RESET}	Input	System reset input	—	—
X1	Input	Crystal connection for main system clock oscillation	—	—
X2	—		—	—
XT1	Input	Crystal connection for subsystem clock oscillation	Input	P07
XT2	—		—	—
V _{DD}	—	Positive power supply	—	—
V _{PP}	—	High-voltage application for program write/verify. Directly connect to V _{SS} in normal operating mode.	—	—
V _{SS}	—	Ground potential	—	—
IC	—	Internally connected. Connect directly to V _{SS} .	—	—

4.1.2 PROM programming mode pins (PROM versions only)

Pin Name	Input/Output	Function
\overline{RESET}	Input	PROM programming mode setting. When +5 V or +12.5 V is applied to the V _{PP} pin or a low level voltage is applied to the \overline{RESET} pin, the PROM programming mode is set.
V _{PP}	Input	High-voltage application for PROM programming mode setting and program write/verify.
A0 to A16	Input	Address bus
D0 to D7	Input/output	Data bus
\overline{CE}	Input	PROM enable input/program pulse input
\overline{OE}	Input	Read strobe input to PROM
\overline{PGM}	Input	Program/program inhibit input in PROM programming mode
V _{DD}	—	Positive power supply
V _{SS}	—	Ground potential

4.2 Description of Pin Functions

4.2.1 P00 to P07 (Port 0)

These are 8-bit input/output ports. Besides serving as input/output ports, they function as an external interrupt request input, an external count clock input to the timer, a capture trigger signal input, and crystal connection for subsystem oscillation.

The following operating modes can be specified in 1-bit units.

(1) Port mode

P00 and P07 function as input-only ports and P01 to P06 function as input/output ports.

P01 to P06 can be specified for input or output ports in 1-bit units with a port mode register 0 (PM0). When they are used as input ports, on-chip pull-up resistors can be used to them by defining the pull-up resistor option register L (PUOL).

(2) Control mode

In this mode, these ports function as an external interrupt request input, an external count clock input to the timer, and crystal connection for subsystem clock oscillation.

(a) INTP0 to INTP6

INTP0 to INTP6 are external interrupt request input pins which can specify valid edges (rising edge, falling edge, and both rising and falling edges). INTP0 or INTP1 becomes a 16-bit timer/event counter capture trigger signal input pin with a valid edge input.

(b) TI00

Pin for external count clock input to 16-bit timer/event counter

(c) TI01

Pin for capture trigger signal to capture register (CR00) of 16-bit timer/event counter

(d) XT1

Crystal connect pin for subsystem clock oscillation

4.2.2 P10 to P17 (Port 1)

These are 8-bit input/output ports. Besides serving as input/output ports, they function as an A/D converter analog input.

The following operating modes can be specified in 1-bit units.

(1) Port mode

These ports function as 8-bit input/output ports.

They can be specified in 1-bit units as input or output ports with a port mode register 1 (PM1). If used as input ports, on-chip pull-up resistors can be used to these ports by defining the pull-up resistor option register L (PUOL).

(2) Control mode

These ports function as A/D converter analog input pins (ANI0 to ANI7). The on-chip pull-up resistor is automatically disabled when the pins specified for analog input.

4.2.3 P20 to P27 (Port 2)

These are 8-bit input/output ports. Besides serving as input/output ports, they function as data input/output to/from the serial interface, clock input/output, automatic transmit/receive busy input, and strobe output functions.

The following operating modes can be specified in 1-bit units.

(1) Port mode

These ports function as 8-bit input/output ports. They can be specified in 1-bit units as input or output ports with port mode register 2 (PM2). When they are used as input ports, on-chip pull-up resistors can be used to them by defining the pull-up resistor option register L (PUOL).

(2) Control mode

These ports function as serial interface data input/output, clock input/output, automatic transmit/receive busy input, and strobe output functions.

(a) SI0, SI1, SO0, SO1, SB0, SB1, SDA0, SDA1

Serial interface serial data input/output pins

(b) $\overline{\text{SCK0}}$, $\overline{\text{SCK1}}$, SCL

Serial interface serial clock input/output pins

(c) BUSY

Serial interface automatic transmit/receive busy input pins

(d) STB

Serial interface automatic transmit/receive strobe output pins

Caution When this port is used as a serial interface, the I/O and output latches must be set according to the function the user requires. For the setting, refer to Figure 17-4 “Serial Operation Mode Register 0 Format” and Figure 18-3 “Serial Operation Mode Register 1 Format.”

4.2.4 P30 to P37 (Port 3)

These are 8-bit input/output ports. Beside serving as input/output ports, they function as timer input/output, clock output, and buzzer output.

The following operating modes can be specified in 1-bit units.

(1) Port mode

These ports function as 8-bit input/output ports. They can be specified in 1-bit units as input or output ports with port mode register 3 (PM3). When they are used as input ports, on-chip pull-up resistors can be used by defining the pull-up resistor option register L (PUOL).

(2) Control mode

These ports function as timer input/output, clock output, and buzzer output.

(a) T11 and T12

Pin for external count clock input to the 8-bit timer/event counter.

(b) T00 to T02

Timer output pins.

(c) PCL

Clock output pin.

(d) BUZ

Buzzer output pin.

4.2.5 P40 to P47 (Port 4)

These are 8-bit input/output ports. Besides serving as input/output ports, they function as an address/data bus. The test input flag (KRIF) can be set to 1 by detecting a falling edge.

The following operating mode can be specified in 8-bit units.

(1) Port mode

These ports function as 8-bit input/output ports. They can be specified in 8-bit units for input or output ports by using the memory expansion mode register (MM). When they are used as input ports, on-chip pull-up resistors can be used by defining the pull-up resistor option register L (PUOL).

(2) Control mode

These ports function as low-order address/data bus pins (AD0 to AD7) in external memory expansion mode. When pins are used as an address/data bus, the on-chip pull-up resistor is automatically disabled.

4.2.6 P50 to P57 (Port 5)

These are 8-bit input/output ports. Besides serving as input/output ports, they function as an address bus.

Port 5 can drive LEDs directly.

The following operating modes can be specified in 1-bit units.

(1) Port mode

These ports function as 8-bit input/output ports. They can be specified in 1-bit units as input/output ports with port mode register 5 (PM5). When they are used as input ports, on-chip pull-up resistors can be used by defining the pull-up resistor option register L (PUOL).

(2) Control mode

These ports function as high-order address bus pins (A8 to A15) in external memory expansion mode. When pins are used as an address bus, the on-chip pull-up resistor is automatically disabled.

4.2.7 P60 to P67 (Port 6)

These are 8-bit input/output ports. Besides serving as input/output ports, they are used for control in external memory expansion mode. P60 to P63 can drive LEDs directly.

The following operating modes can be specified in 1-bit units.

(1) Port mode

These ports function as 8-bit input/output ports. They can be specified in 1-bit units as input or output ports with port mode register 6 (PM6).

P60 to P63 are N-ch open drain outputs. Mask ROM version can contain pull-up resistors with the mask option.

When P64 to P67 are used as input ports, on-chip pull-up resistors can be used by defining the pull-up resistor option register L (PUOL).

(2) Control mode

These ports function as control signal output pins (\overline{RD} , \overline{WR} , \overline{WAIT} , ASTB) in external memory expansion mode. When a pin is used as a control signal output, the on-chip pull-up resistor is automatically disabled.

Caution When external wait is not used in external memory expansion mode, P66 can be used as an input/output port.

4.2.8 P70 to P72 (Port 7)

This is a 3-bit input/output port. In addition to its use as an input/output port, it also has serial interface data input/output and clock input/output functions.

The following operating modes can be specified in 1-bit units.

(1) Port mode

Port 7 functions as a 3-bit input/output port. 1-bit-units specification as an input port or output port is possible by means of port mode register 7 (PM7). When used as input ports, on-chip pull-up resistors can be used by defining the pull-up resistor option register L (PUOL).

(2) Control mode

Port 7 functions as serial interface data input/output and clock input/output.

(a) SI2, SO2

Serial interface serial data input/output pins

(b) $\overline{\text{SCK2}}$

Serial interface serial clock input/output pin.

(c) RxD, TxD

Asynchronous serial interface serial data input/output pins.

(d) ASCK

Asynchronous serial interface serial clock input/output pin.

Caution When this port is used as a serial interface, the I/O and output latches must be set according to the function the user requires.

For the setting, see to the operation mode setting list in Table 19-2 "Serial Interface Channel 2".

4.2.9 P120 to P127 (Port 12)

These are 8-bit input/output ports. Besides serving as input/output ports, they function as a real-time output port. The following operating modes can be specified in 1-bit units.

(1) Port mode

These ports function as 8-bit input/output ports. They can be specified in 1-bit units as input or output ports with port mode register 12 (PM12). When they are used as input ports, on-chip pull-up resistors can be used by defining the pull-up resistor option register H (PUOH).

(2) Control mode

These ports function as real-time output ports (RTP0 to RTP7) outputting data in synchronization with a trigger.

4.2.10 P130 and P131 (Port 13)

These are 2-bit input/output ports. Besides serving as input/output ports, they are used for D/A converter analog output.

The following operating modes can be specified in 1-bit units.

(1) Port mode

These ports function as 2-bit input/output ports. They can be specified in 1-bit units as input or output ports with port mode register 13 (PM13). When they are used as input ports, on-chip pull-up resistors can be used by defining the pull-up resistor option register H (PUOH).

(2) Control mode

These ports allow D/A converter analog output (ANO0 and ANO1).

Caution When only either one of the D/A converter channels is used with $AV_{REF1} < V_{DD}$, the other pins that are not used as analog outputs must be set as follows:

- Set PM13x bit of the port mode register 13 (PM13) to 1 (input mode) and connect the pin to V_{SS} .
- Set PM13x bit of the port mode register 13 (PM13) to 0 (output mode) and the output latch to 0, to output low level from the pin.

4.2.11 AV_{REF0}

A/D converter reference voltage input pin.

When A/D converter is not used, connect this pin to V_{SS} .

4.2.12 AV_{REF1}

D/A converter reference voltage input pin.

When D/A converter is not used, connect this pin to V_{DD} .

4.2.13 AV_{DD}

Analog power supply pin of A/D converter. Always use the same voltage as that of the V_{DD} pin even when A/D converter is not used.

4.2.14 AV_{SS}

This is a ground voltage pin of A/D converter and D/A converter. Always use the same voltage as that of the V_{SS} pin even when neither A/D nor D/A converter is used.

4.2.15 $\overline{\text{RESET}}$

This is a low-level active system reset input pin.

4.2.16 X1 and X2

Crystal resonator connect pins for main system clock oscillation. For external clock supply, input it to X1 and its inverted signal to X2.

4.2.17 XT1 and XT2

Crystal resonator connect pins for subsystem clock oscillation.

For external clock supply, input it to XT1 and its inverted signal to XT2.

4.2.18 V_{DD}

Positive power supply pin

4.2.19 V_{SS}

Ground potential pin

4.2.20 V_{PP} (PROM versions only)

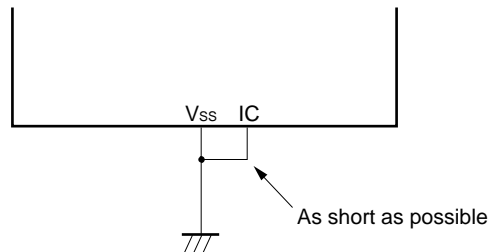
High-voltage apply pin for PROM programming mode setting and program write/verify. Directly connect to V_{SS} in the normal operating mode.

4.2.21 IC (Mask ROM version only)

The IC (Internally Connected) pin is provided to set the test mode to check the μ PD78054Y Subseries before shipment. Directly connect the pin to the V_{SS} with the shortest possible wire in the normal operating mode.

When a voltage difference is produced between the IC pin and V_{SS} pin because the wiring between those two pins is too long or an external noise is input to the IC pin, the user's program may not run normally.

- Directly connect IC pins to V_{SS} pins.



4.3 Input/output Circuits and Recommended Connection of Unused Pins

Table 4-1 shows the input/output circuit types of pins and the recommended conditions for unused pins. Refer to Figure 4-1 for the configuration of the input/output circuit of each type.

Table 4-1. Pin Input/Output Circuit Types (1/2)

Pin Name	Input/Output Circuit Type	Input/Output	Recommended Connection of Unused Pins		
P00/INTP0/TI00	2	Input	Connect to V_{SS} .		
P01/INTP1/TI01	8-A	Input/Output	Individually connect to V_{SS} via a resistor.		
P02/INTP2					
P03/INTP3					
P04/INTP4					
P05/INTP5					
P06/INTP6					
P07/XT1	16	Input	Connect to V_{DD} .		
P10/ANI0 to P17/ANI7	11	Input/Output	Individually connect to V_{DD} or V_{SS} via a resistor.		
P20/SI1	8-A				
P21/SO1	5-A				
P22/SCK1	8-A				
P23/STB	5-A				
P24/BUSY	8-A				
P25/SI0/SB0/SDA0	10-A				
P26/SO0/SB1/SDA1					
P27/SCK0/SCL					
P30/TO0	5-A				
P31/TO1					
P32/TO2					
P33/TI1	8-A				
P34/TI2					
P35/PCL	5-A				
P36/BUZ					
P37					
P40/AD0 to P47/AD7	5-E			Input/Output	Individually connect to V_{DD} via a resistor.
P50/A8 to P57/A15	5-A			Input/output	Individually connect to V_{DD} or V_{SS} via a resistor.

Table 4-1. Pin Input/Output Circuit Types (2/2)

Pin Name	Input/Output Circuit Type	Input/Output	Recommended Connection of Unused Pins	
P60 to P63 (Mask ROM version)	13-B	Input/output	Individually connect to V_{DD} via a resistor.	
P60 to P63 (PROM version)	13-D	Input/output	Individually connect to V_{DD} or V_{SS} via a resistor.	
P64/ \overline{RD}	5-A			
P65/ \overline{WR}				
P66/ \overline{WAIT}				
P67/ \overline{ASTB}				
P70/SI2/RxD	8-A			
P71/SO2/TxD	5-A			
P72/ $\overline{SCK2}$ / \overline{ASCK}	8-A			
P120/RTP0 to P127/RTP7	5-A			
P130/ANO0 to P131/ANO1	12-A	Input/output	Individually connect to V_{SS} via a resistor.	
\overline{RESET}	2	Input	—	
XT2	16	—	Leave open.	
AV_{REF0}	—		Connect to V_{SS} .	
AV_{REF1}			Connect to V_{DD} .	
AV_{DD}			Connect to V_{SS} .	
AV_{SS}				
IC (Mask ROM version)				Directly connect to V_{SS} .
V_{PP} (PROM version)				

Figure 4-1. Pin Input/Output Circuit of List (1/2)

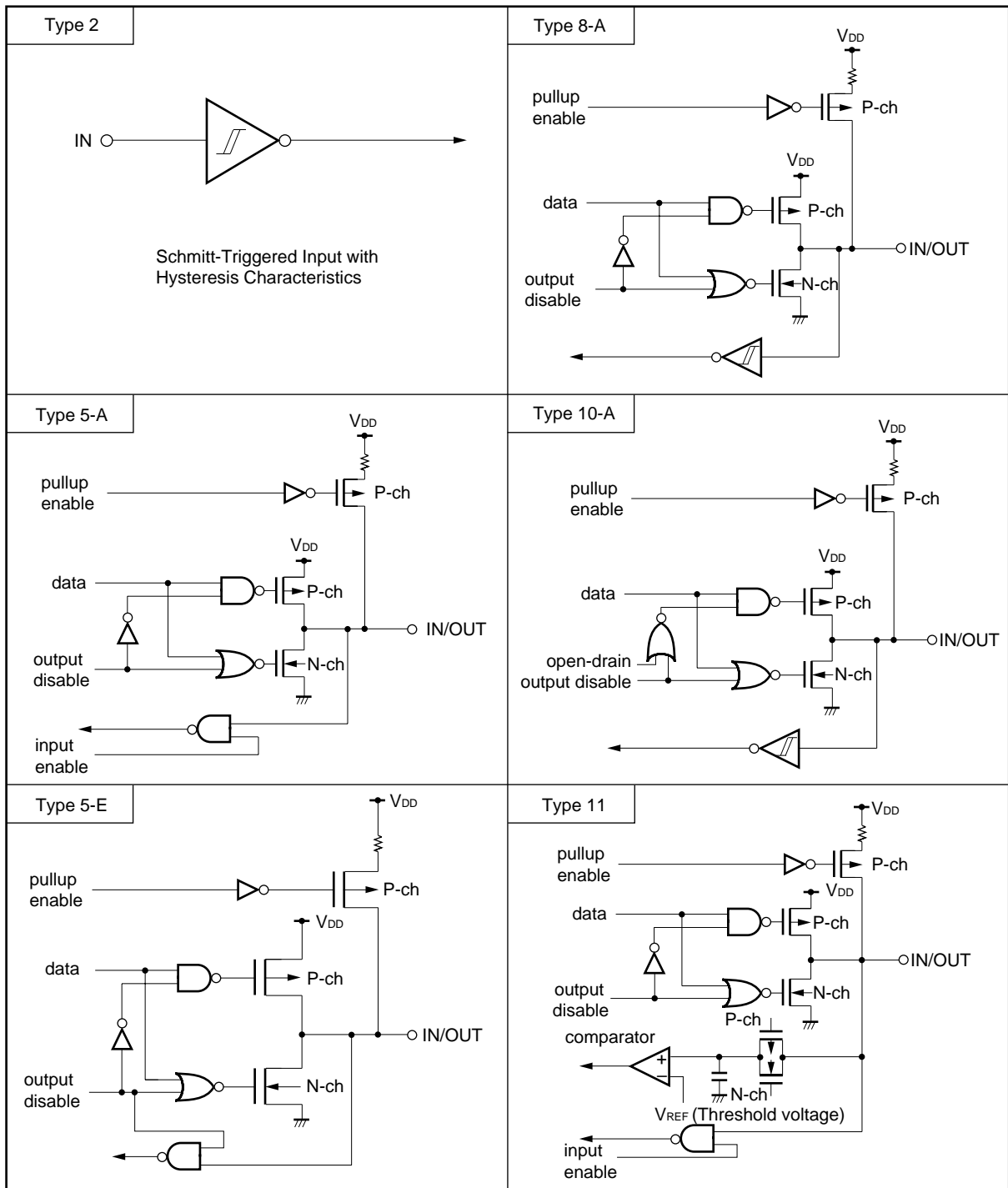
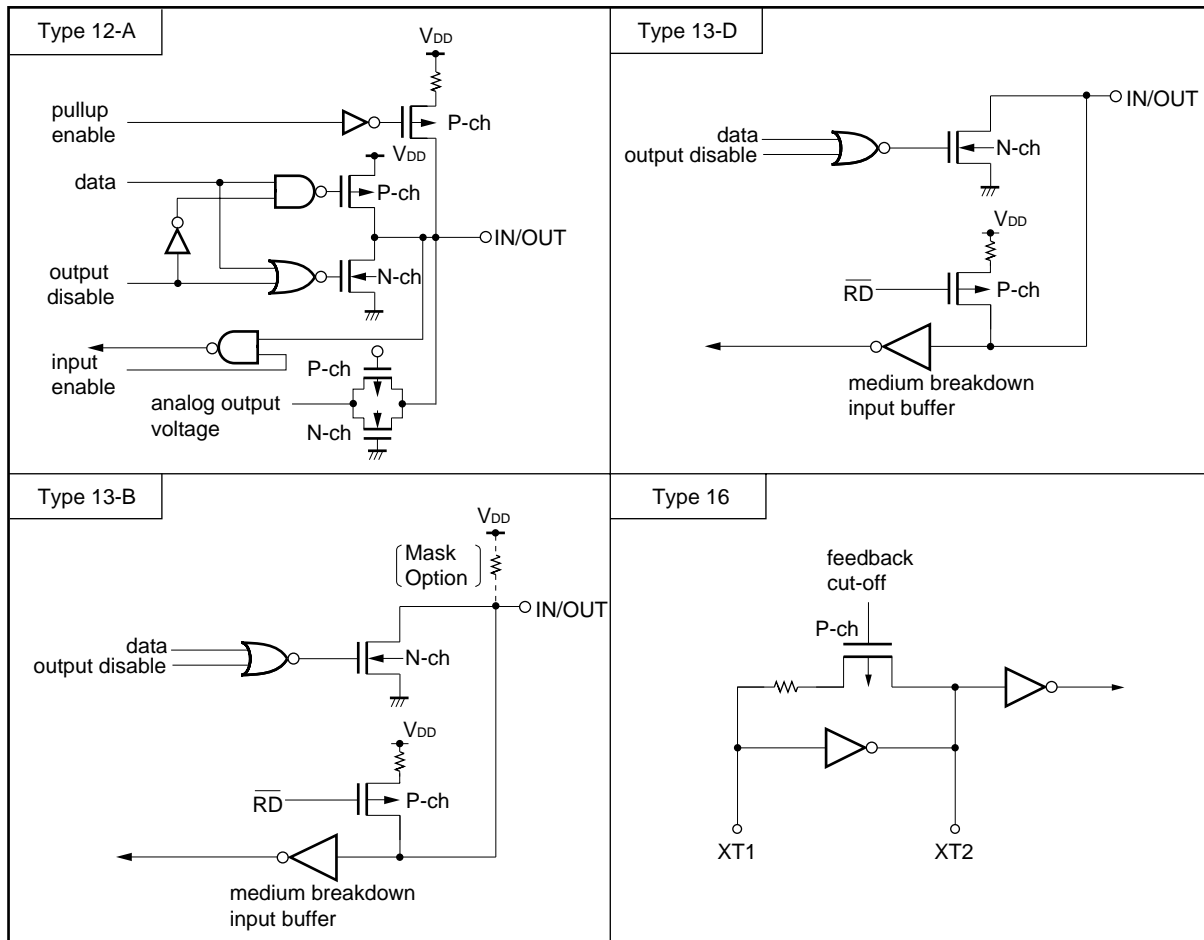


Figure 4-1. Pin Input/Output Circuit of List (2/2)



CHAPTER 5 CPU ARCHITECTURE

5.1 Memory Spaces

Each product of the μ PD78054 and 78054Y Subseries can access the memory space of 64 Kbytes. Figures 5-1 to 5-8 show memory maps.

Figure 5-1. Memory Map (μ PD78052, 78052Y)

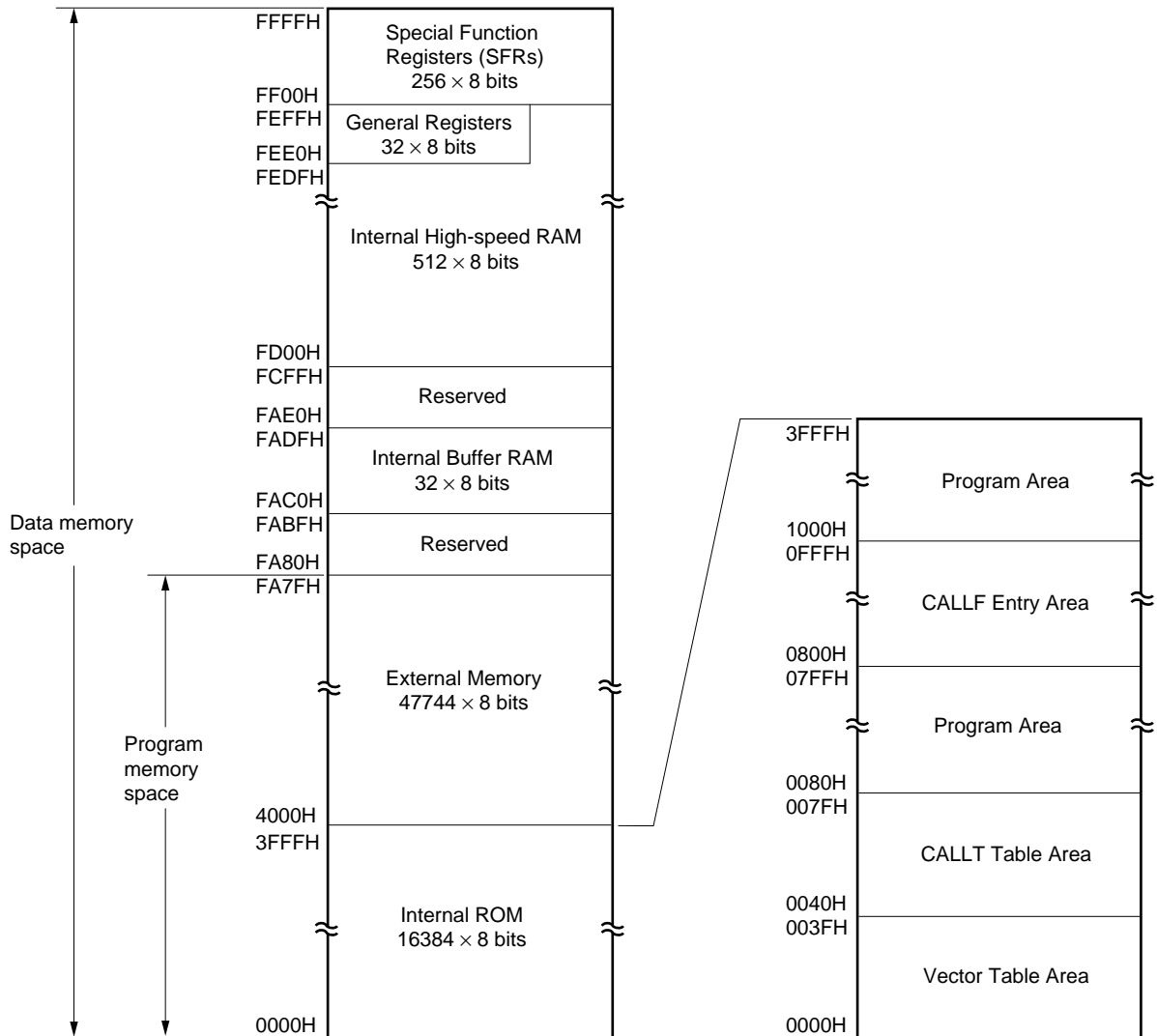


Figure 5-2. Memory Map (μ PD78053, 78053Y)

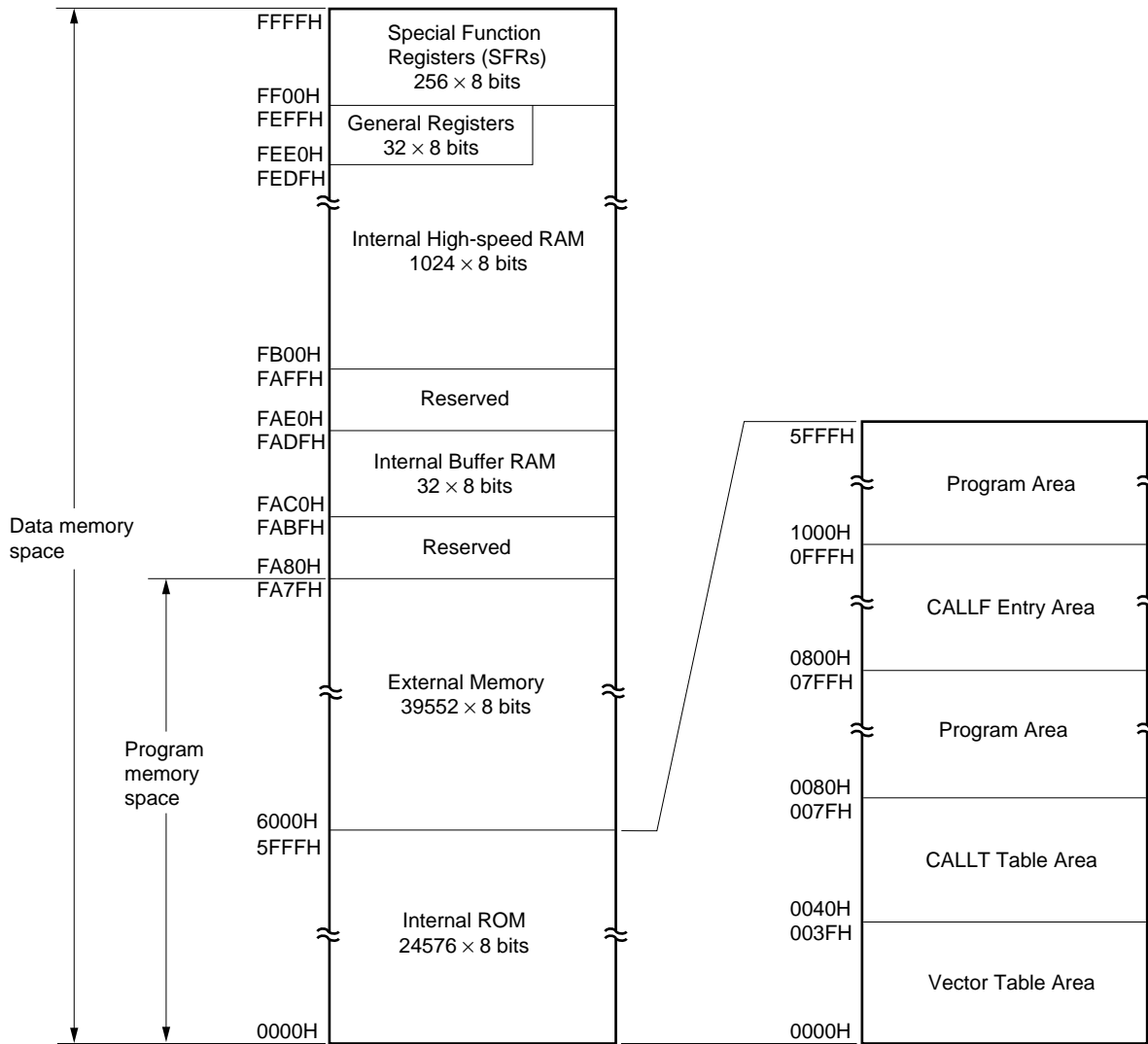


Figure 5-3. Memory Map (μ PD78054, 78054Y)

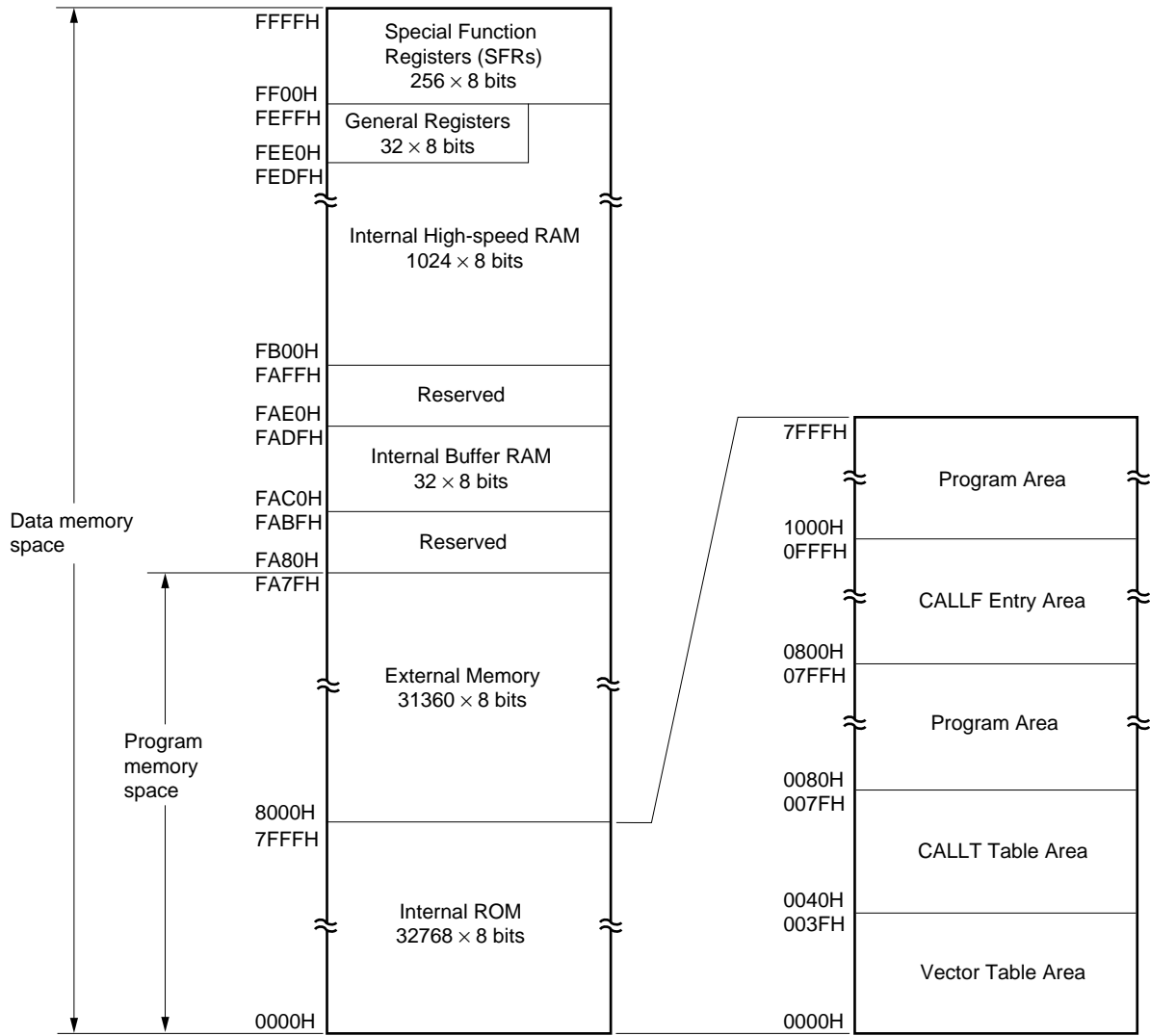


Figure 5-4. Memory Map (μ PD78P054)

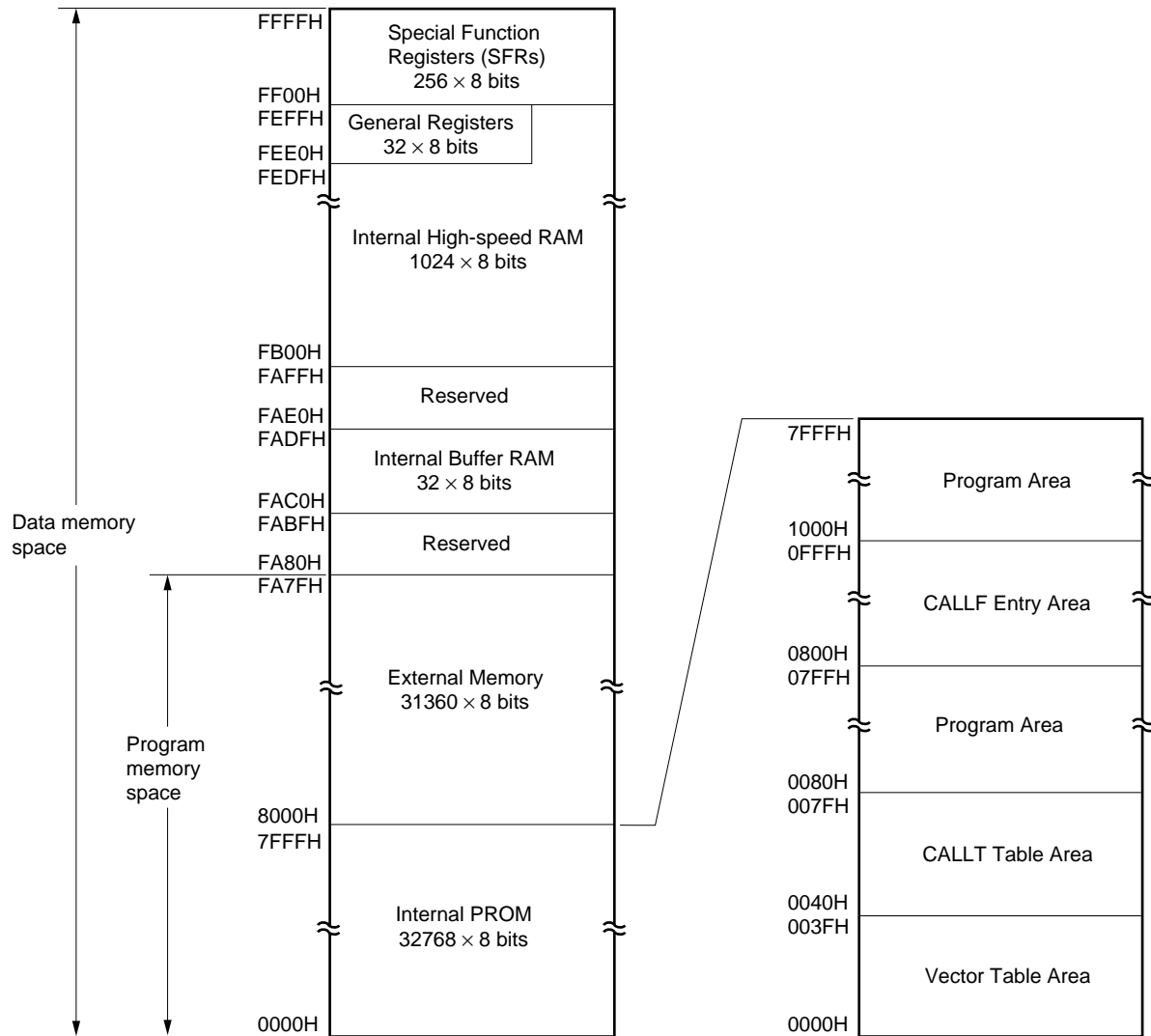


Figure 5-5. Memory Map (μ PD78055, 78055Y)

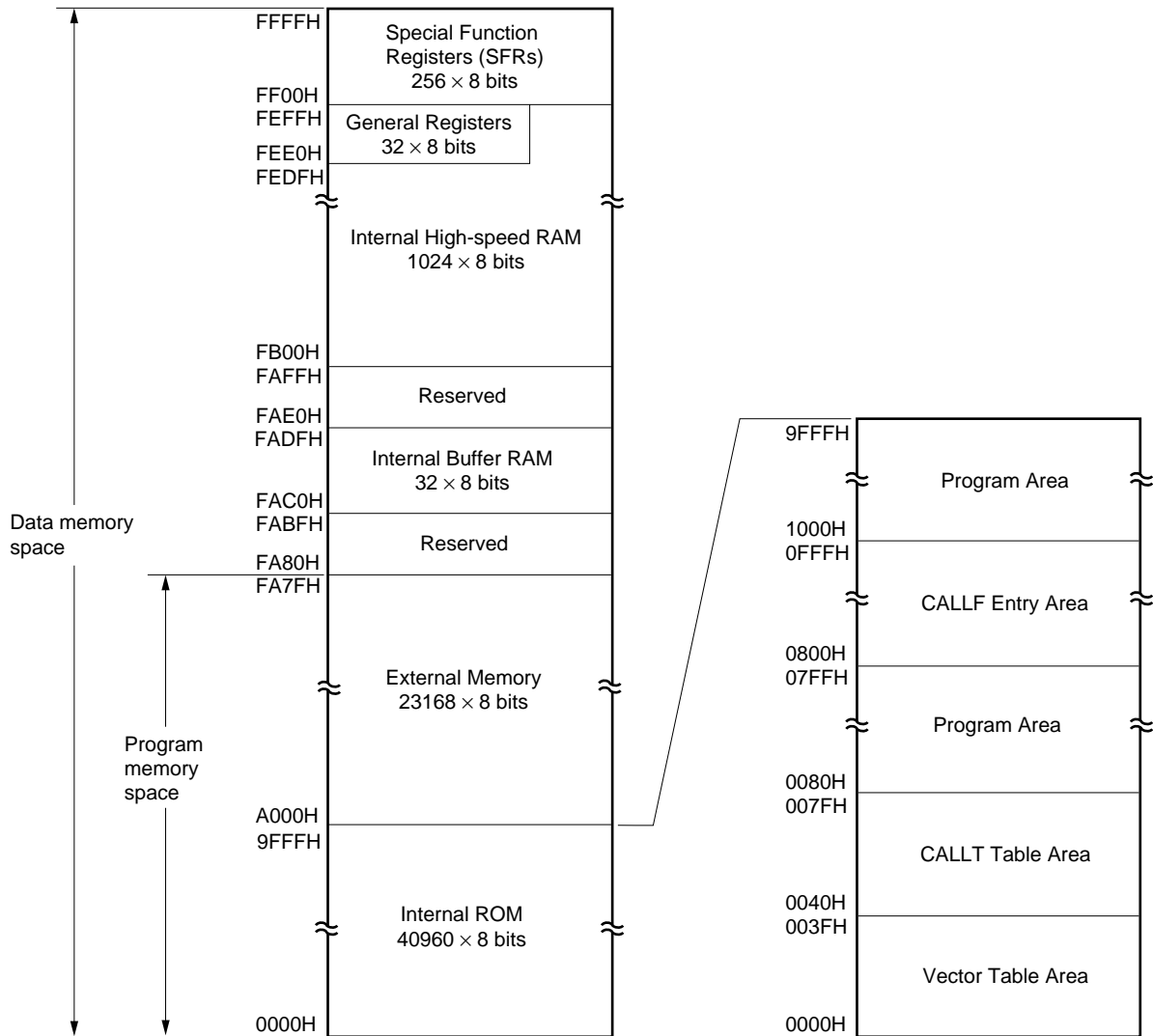


Figure 5-6. Memory Map (μ PD78056, 78056Y)

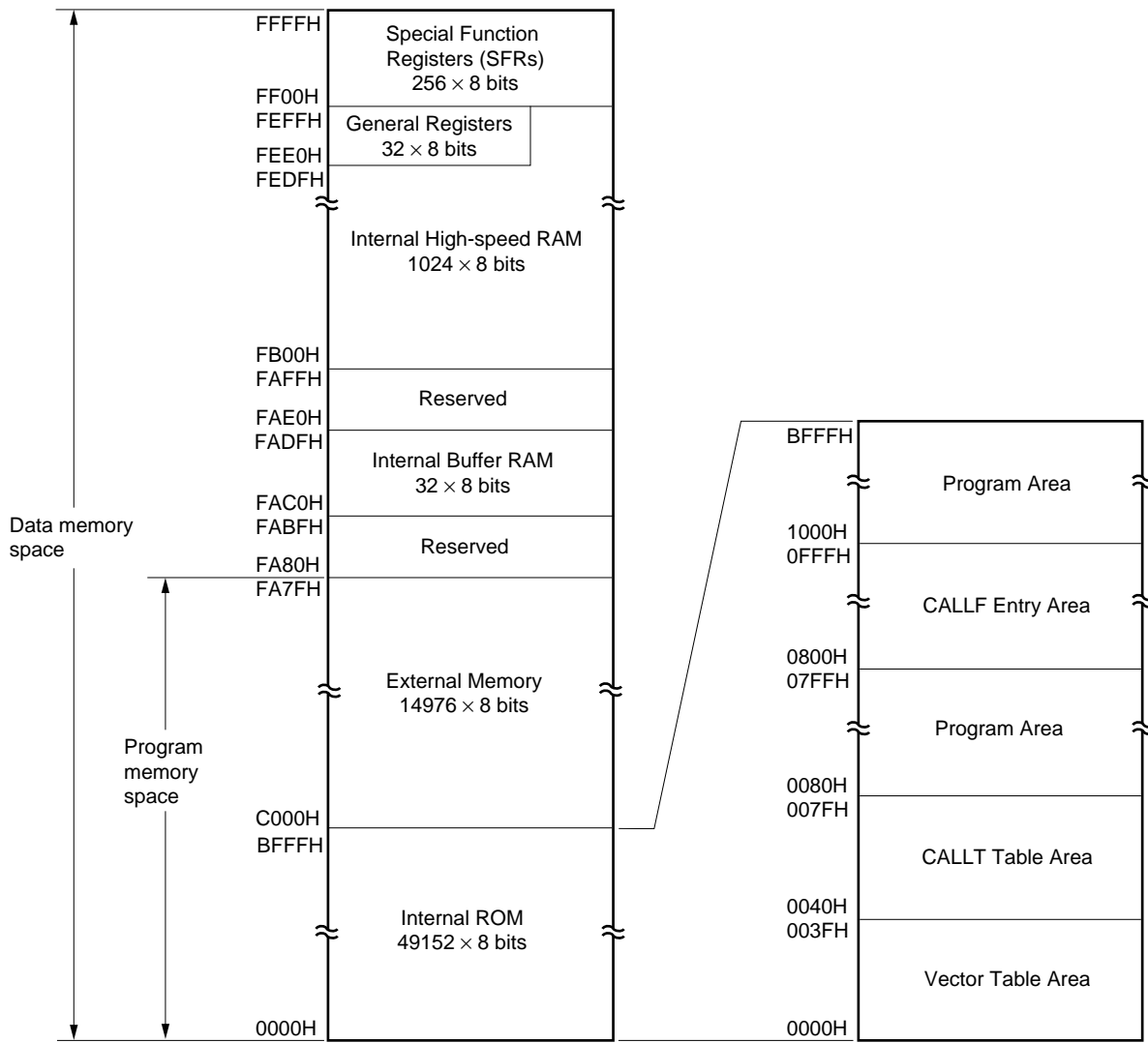
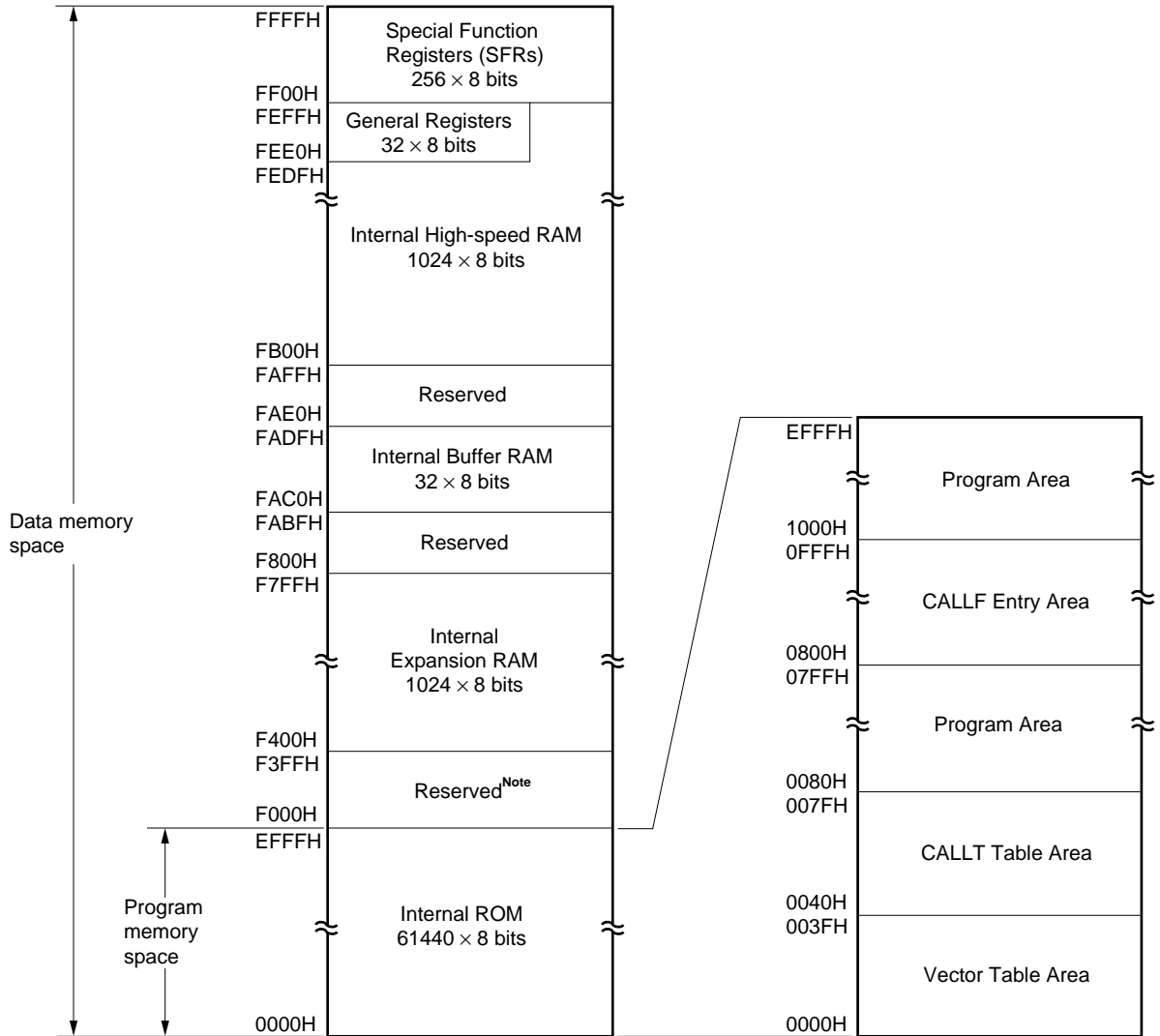
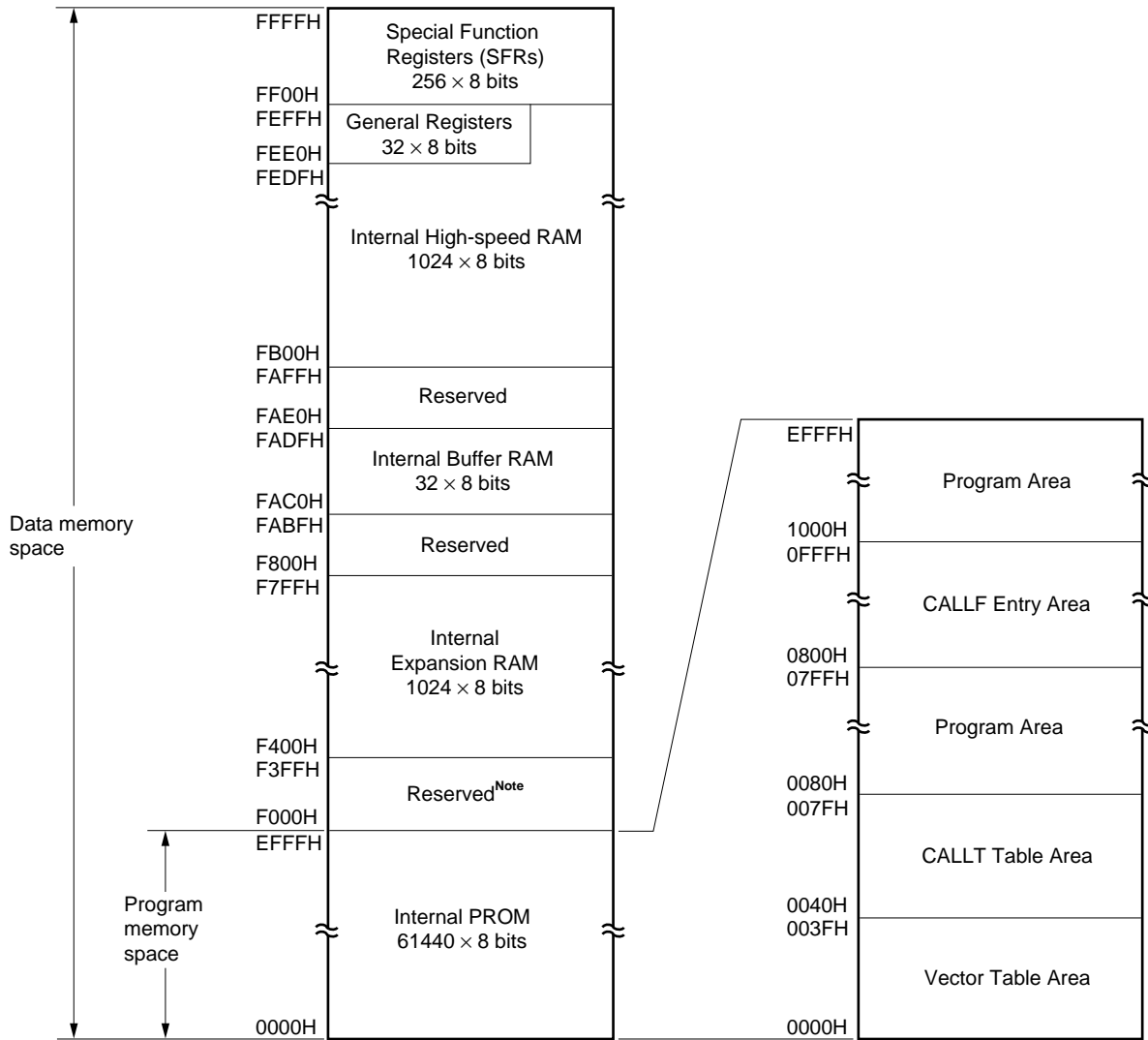


Figure 5-7. Memory Map (μ PD78058, 78058Y)



Note When internal ROM size is 60K bytes, the area F000H to F3FFH cannot be used. F000H to F3FFH can be used as external memory by setting the internal ROM size to less than 56K bytes by the memory size switching register (IMS).

Figure 5-8. Memory Map (μ PD78P058, μ PD78P058Y)



Note When internal PROM size is 60K bytes, the area F000H to F3FFH cannot be used. F000H to F3FFH can be used as external memory by setting the internal PROM size to less than 56K bytes by the memory size switching register (IMS).

5.1.1 Internal program memory space

The internal program memory space stores programs and table data. Normally, they are addressed with a program counter (PC).

Each product of the μ PD78054 and 78054Y Subseries has the internal ROM (or PROM) of the size shown below.

Table 5-1. Internal ROM Capacity

Part number	Internal ROM	
	Type	Capacity
μ PD78052, 78052Y	Mask ROM	16384 x 8 bits (0000H to 3FFFH)
μ PD78053, 78053Y		24576 x 8 bits (0000H to 5FFFH)
μ PD78054, 78054Y		32768 x 8 bits (0000H to 7FFFH)
μ PD78055, 78055Y		40960 x 8 bits (0000H to 9FFFH)
μ PD78056, 78056Y		49152 x 8 bits (0000H to BFFFH)
μ PD78058, 78058Y		61440 x 8 bits (0000H to EFFFH)
μ PD78P054	PROM	32768 x 8 bits (0000H to 7FFFH)
μ PD78P058, 78P058Y		61440 x 8 bits (0000H to EFFFH)

The following areas are allocated to the internal program memory space.

(1) Vector table area

The 64-byte area 0000H to 003FH is reserved as a vector table area. The $\overline{\text{RESET}}$ input and program start addresses for branch upon generation of each interrupt request are stored in the vector table area. Of the 16-bit address, low-order 8 bits are stored at even addresses and high-order 8 bits are stored at odd addresses.

Table 5-2. Vector Table

Vector Table Address	Interrupt Source	Vector Table Address	Interrupt Source
0000H	$\overline{\text{RESET}}$ input	0018H	INTSER
0004H	INTWDT	001AH	INTSR/INTCSI2
0006H	INTP0	001CH	INTST
0008H	INTP1	001EH	INTTM3
000AH	INTP2	0020H	INTTM00
000CH	INTP3	0022H	INTTM01
000EH	INTP4	0024H	INTTM1
0010H	INTP5	0026H	INTTM2
0012H	INTP6	0028H	INTAD
0014H	INTCSI0	003EH	BRK
0016H	INTCSI1		

(2) CALLT instruction table area

The 64-byte area 0040H to 007FH can store the subroutine entry address of a 1-byte call instruction (CALLT).

(3) CALLF instruction entry area

The area 0800H to 0FFFH can perform a direct subroutine call with a 2-byte call instruction (CALLF).

5.1.2 Internal data memory space

The μ PD78054 and 78054Y subseries units incorporate the following RAMs.

(1) Internal high-speed RAM

The μ PD78054 and 78054Y Subseries are provided with the internal high-speed RAM as shown below.

Table 5-3. Internal High-Speed RAM Capacity

Part Number	Internal High-Speed RAM
μ PD78052, 78052Y	512 \times 8 bits (FD00H to FEFFH)
μ PD78053, 78053Y	1024 \times 8 bits (FB00H to FEFFH)
μ PD78054, 78054Y	
μ PD78P054	
μ PD78055, 78055Y	
μ PD78056, 78056Y	
μ PD78058, 78058Y	
μ PD78P058, 78P058Y	

In this area, four banks of general registers, each bank consisting of eight 8-bit registers, are allocated in the 32-byte area FEE0H to FEFFH.

The internal high-speed RAM can also be used as a stack memory.

(2) Buffer RAM

Buffer RAM is allocated to the 32-byte area from FAC0H to FADFH. The buffer RAM is used to store transmit/receive data of serial interface channel 1 (in three-wire serial I/O mode with automatic transfer/receive function). If the three-wire serial I/O mode with automatic transfer/receive function is not used, the buffer RAM can also be used as normal RAM. Buffer RAM can also be used as normal RAM.

(3) Internal expansion RAM (μ PD78058, 78058Y, 78P058, 78P058Y only)

Internal expansion RAM is allocated to the 1024-byte area from F400H to F7FFH.

5.1.3 Special Function Register (SFR) area

An on-chip peripheral hardware special-function register (SFR) is allocated in the area FF00H to FFFFH. (Refer to **Table 5-6. Special-Function Register List** in **5.2.3 Special Function Register (SFR)**).

Caution Do not access addresses where the SFR is not assigned.

5.1.4 External memory space

The external memory space is accessible by setting the memory expansion mode register (MM). External memory space can store program, table data, etc. and allocate peripheral devices.

5.1.5 Data memory addressing

The method to specify the address of the instruction to be executed next, or the address of a register or memory to be manipulated when an instruction is executed is called addressing.

The address of the instruction to be executed next is addressed by the program counter PC (for details, refer to **5.3 Instruction Address Addressing**).

To address the memory that is manipulated when an instruction is executed, the μ PD78054, 78054Y Subseries is provided with many addressing modes with a high operability. Especially at addresses corresponding to data memory area, particular addressing modes are possible to meet the functions of the special function registers (SFRs) and general registers. This area is between FD00H and FFFFH for the μ PD78052 and 78052Y, and between FB00H and FFFFH for the μ PD78053, 78053Y, 78054, 78054Y, 78P054, 78055, 78055Y, 78056, 78056Y, 78058, 78058Y, 78P058, and 78P058Y. The data memory space is the entire 64K-byte space (0000H to FFFFH). Figure 5-9 to 5-16 show the data memory addressing modes. For details of each addressing, refer to **5.4 Operand Address Addressing**.

Figure 5-9. Data Memory Addressing (μ PD78052, 78052Y)

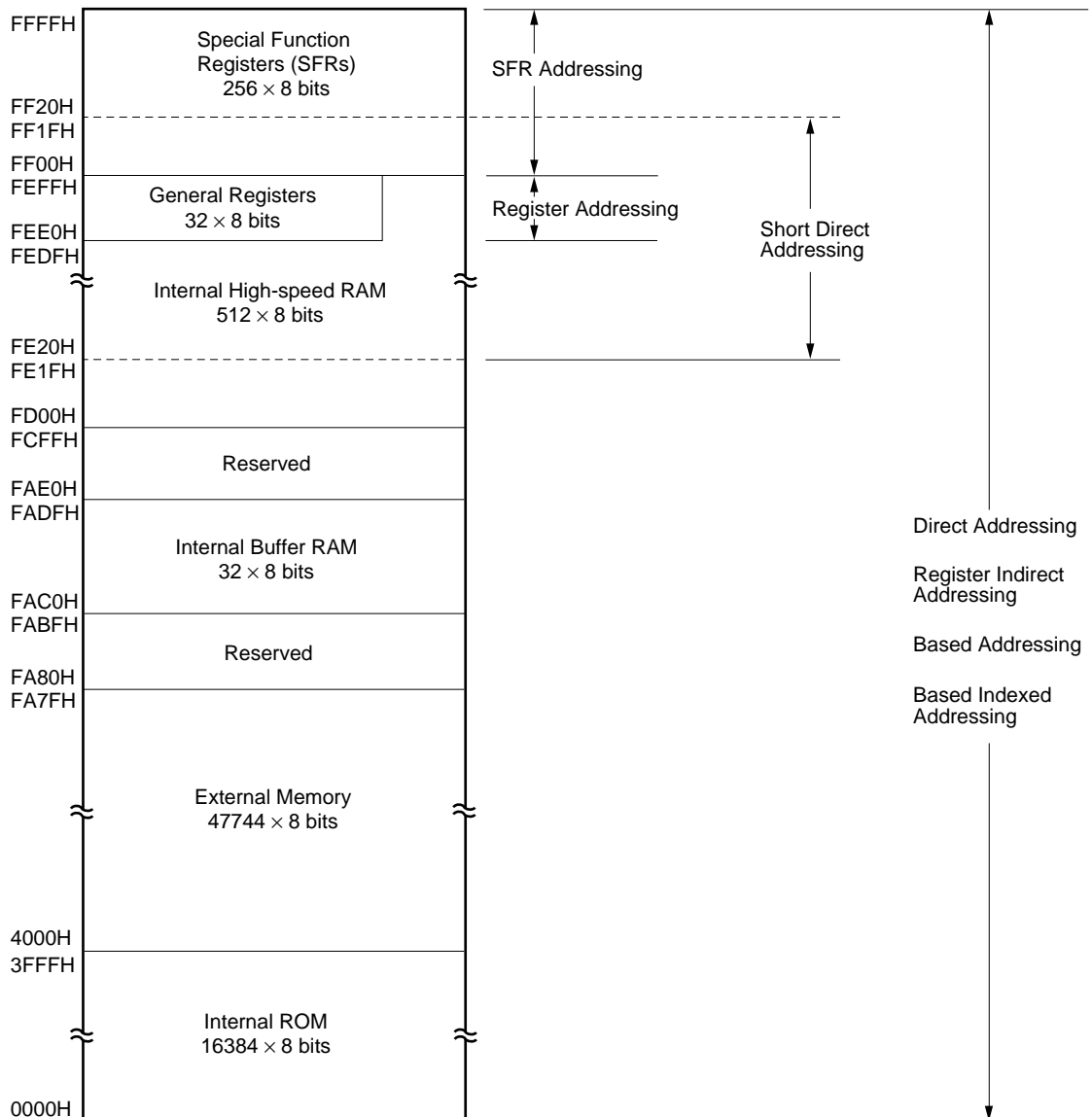


Figure 5-10. Data Memory Addressing (μ PD78053, 78053Y)

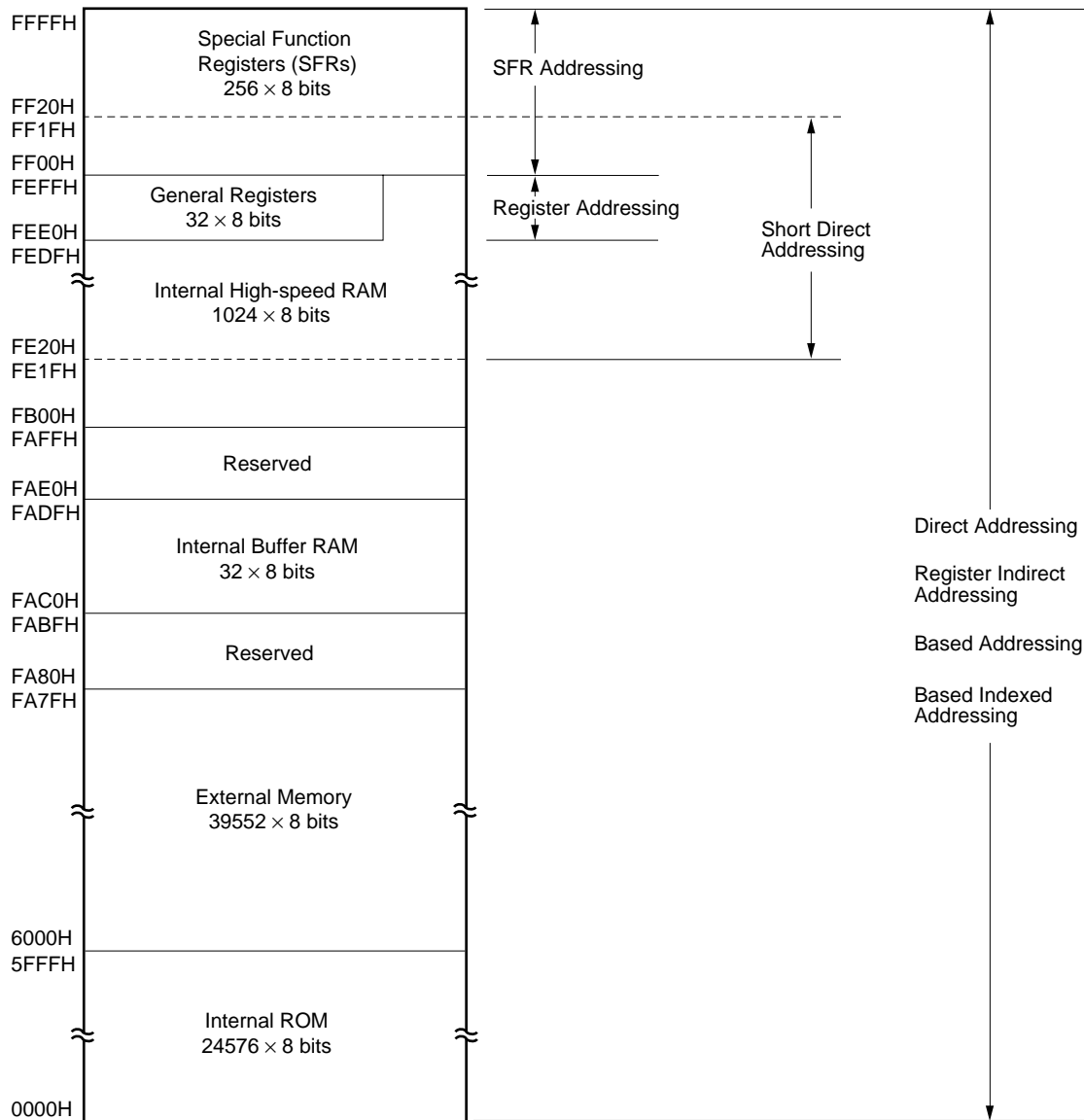


Figure 5-11. Data Memory Addressing (μ PD78054, 78054Y)

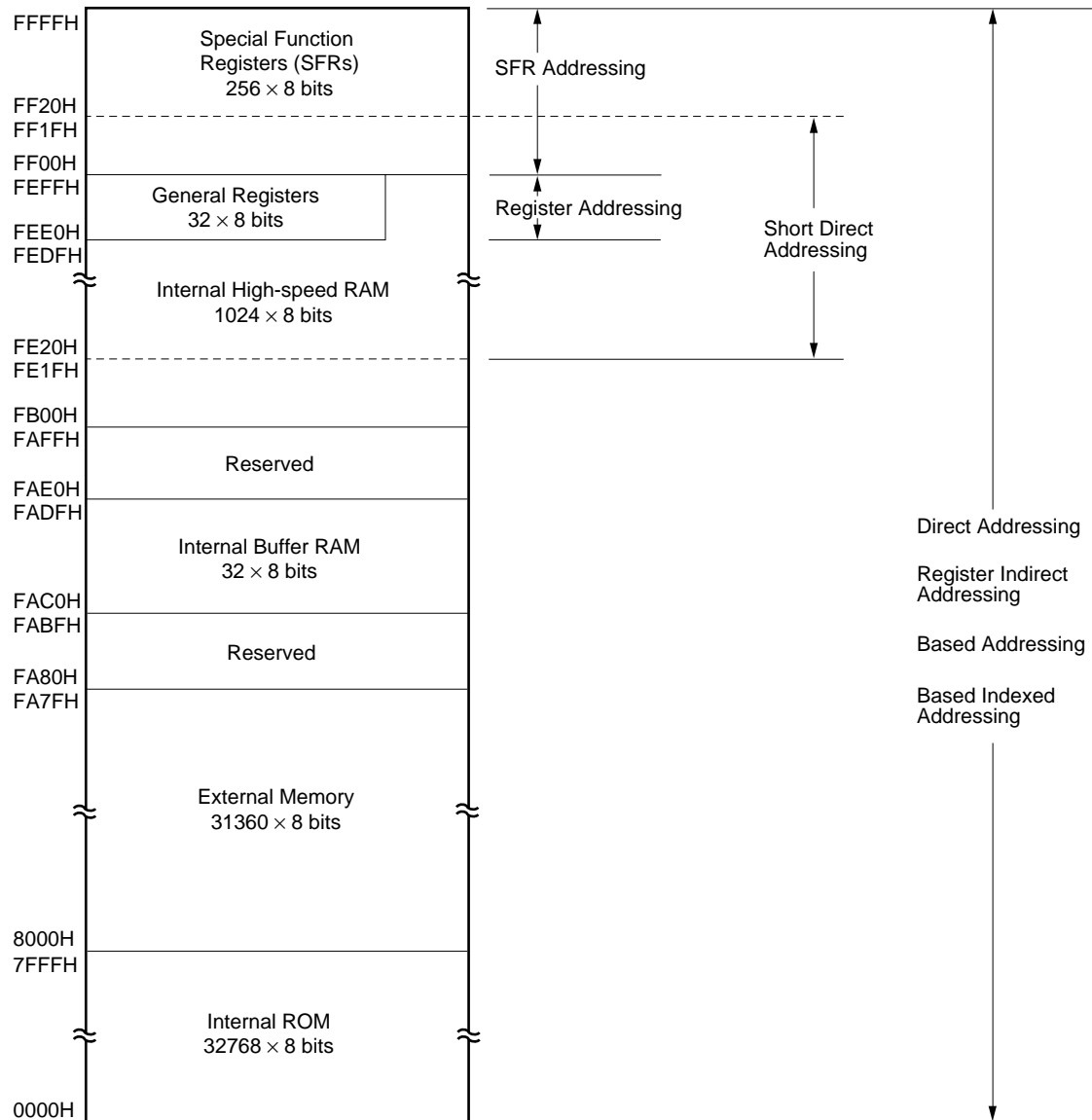


Figure 5-12. Data Memory Addressing (μ PD78P054)

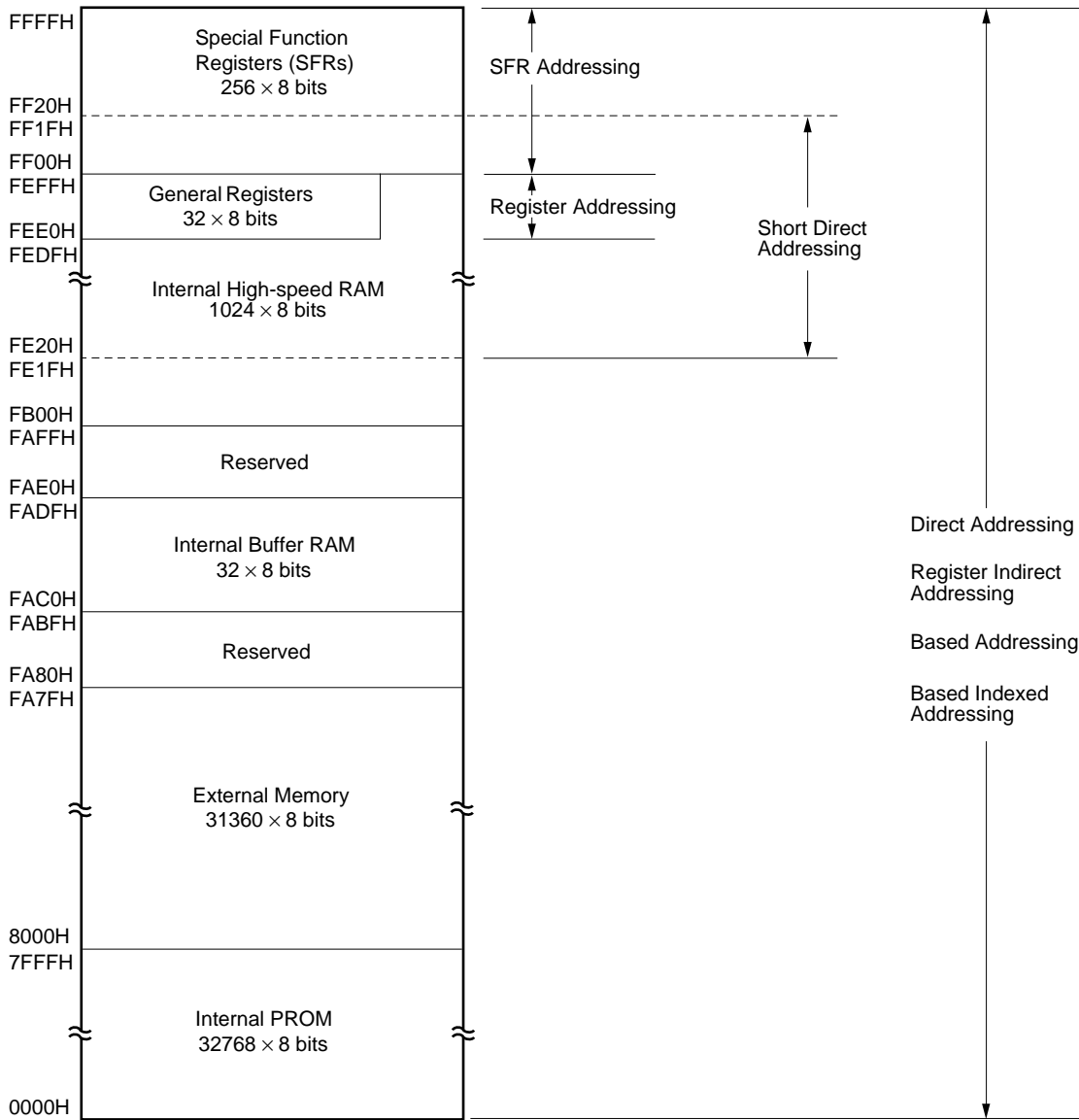


Figure 5-13. Data Memory Addressing (μ PD78055, 78055Y)

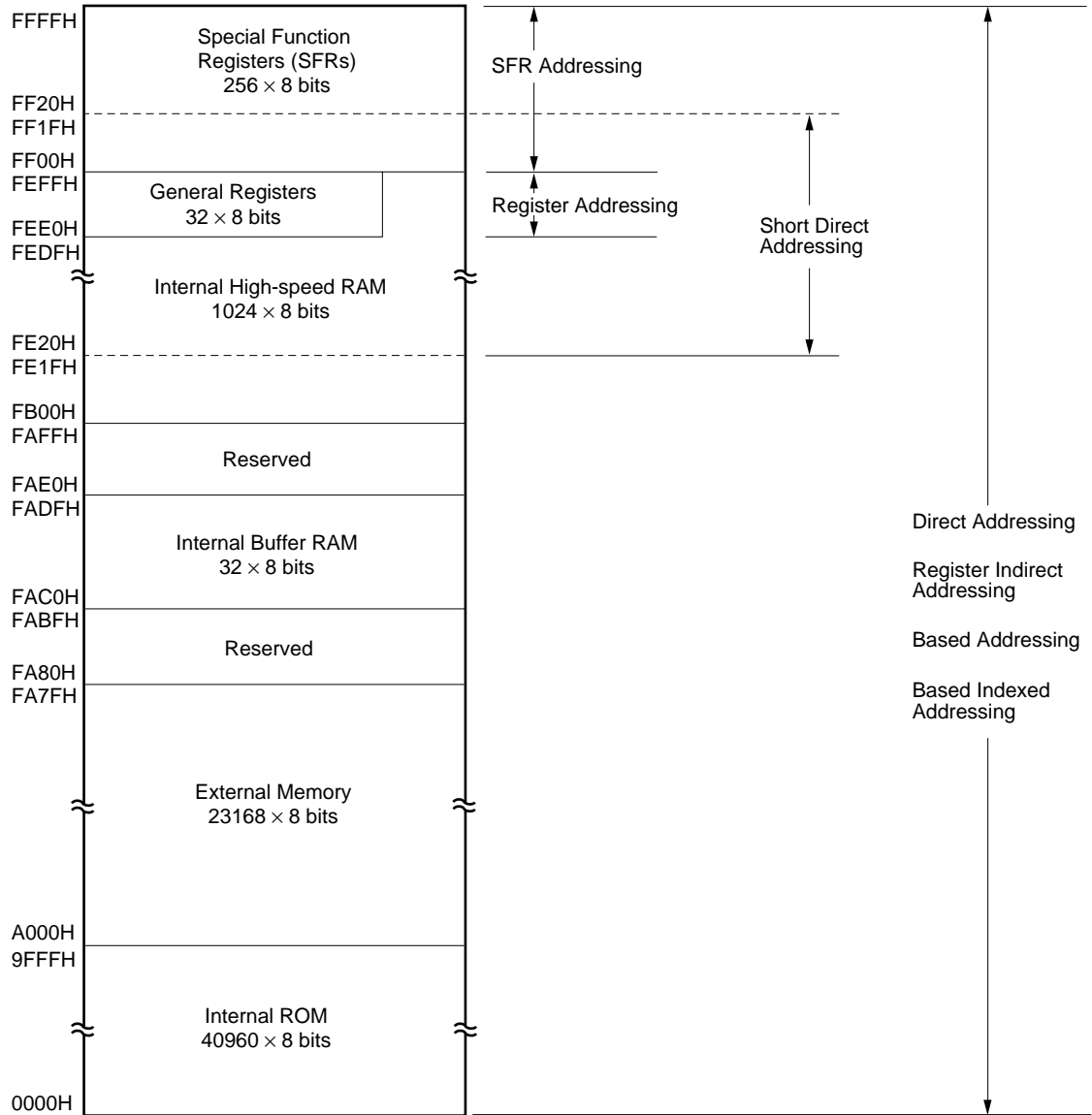


Figure 5-14. Data Memory Addressing (μ PD78056, 78056Y)

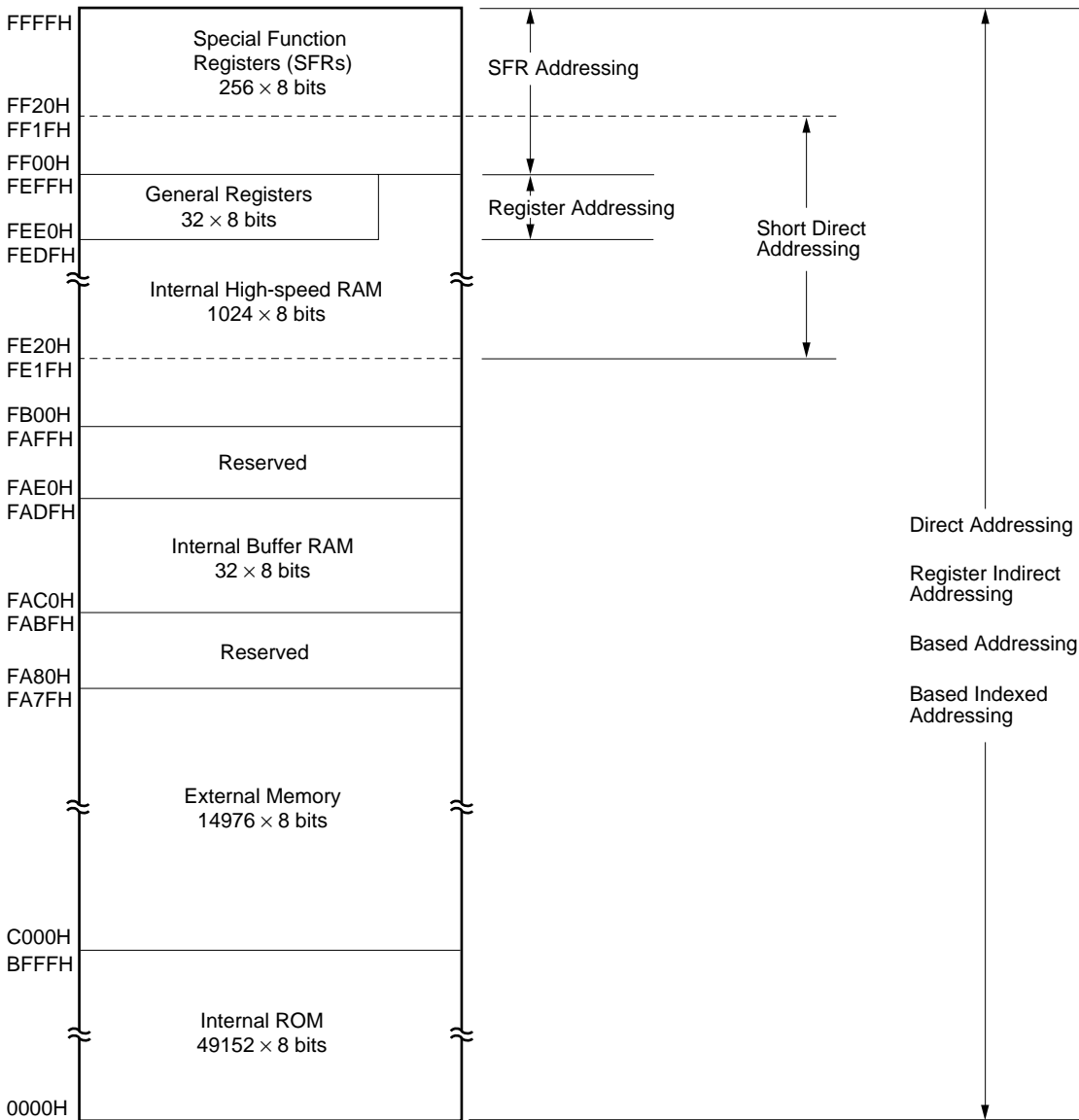
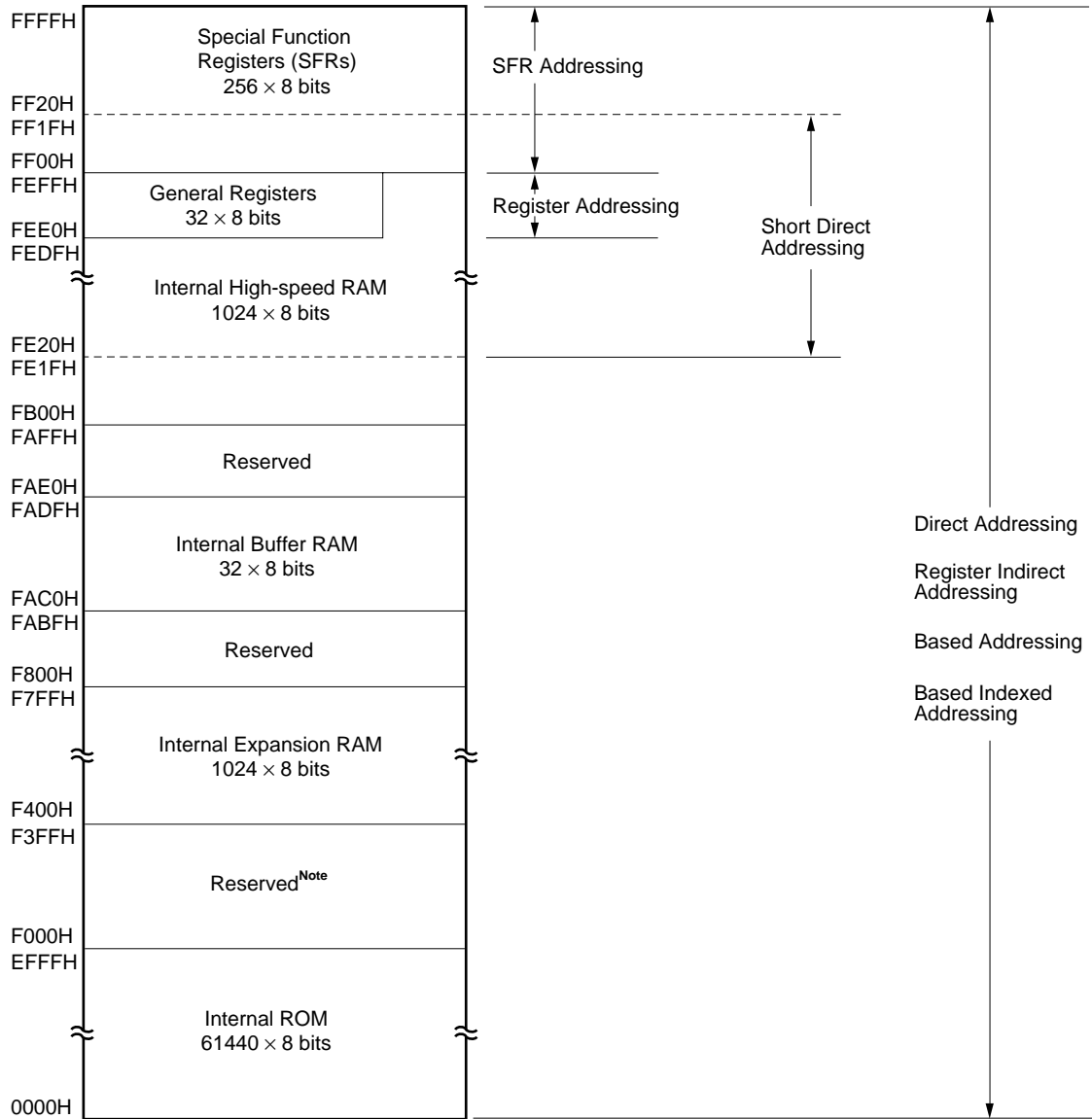
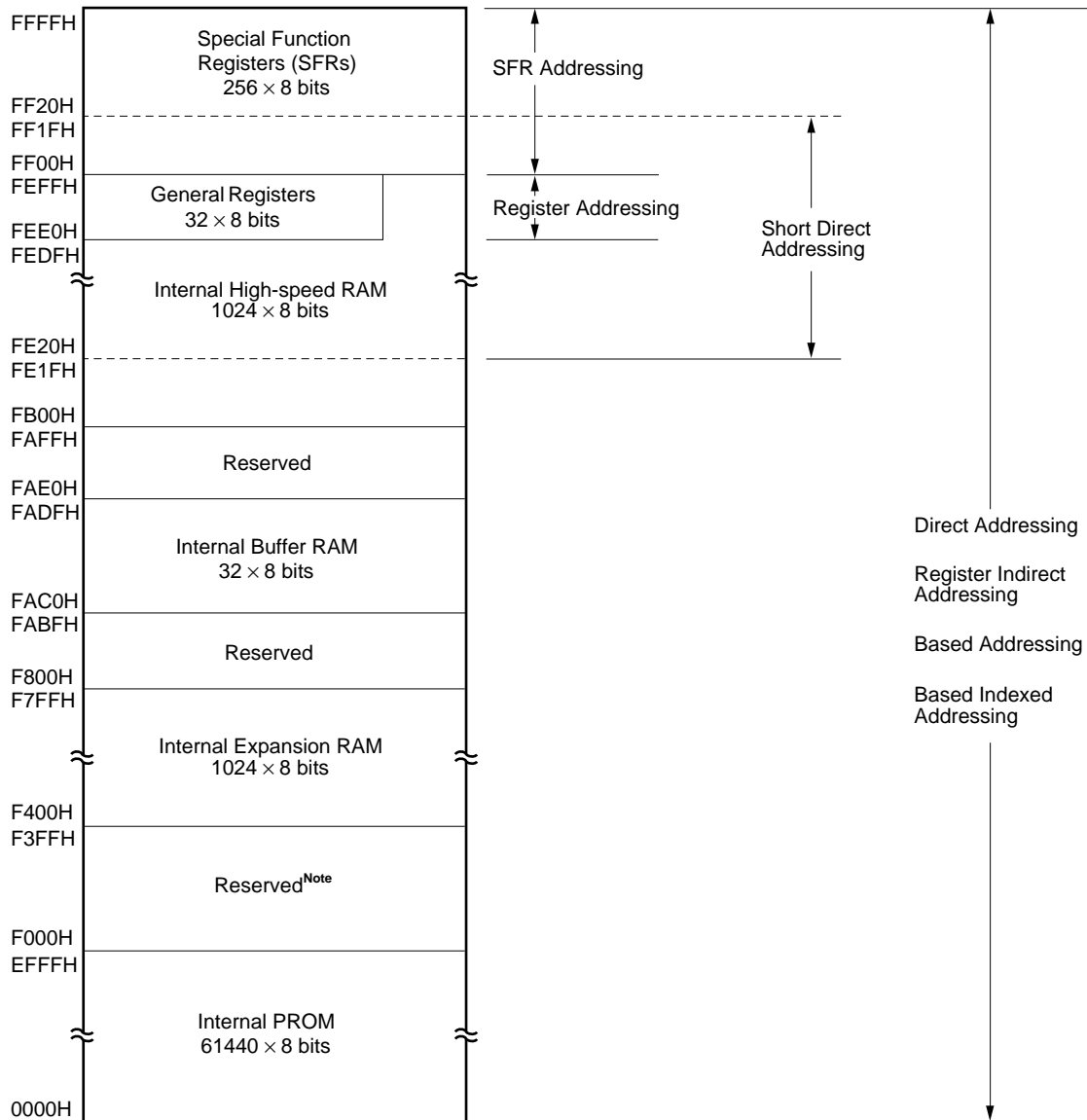


Figure 5-15. Data Memory Addressing (μ PD78058, 78058Y)



Note When internal ROM size is 60K bytes, the area F000H to F3FFH cannot be used. F000H to F3FFH can be used as external memory by setting the internal ROM size to less than 56K bytes by the memory size switching register.

Figure 5-16. Data Memory Addressing (μ PD78P058, 78P058Y)



Note When internal PROM size is 60K bytes, the area F000H to F3FFH cannot be used. F000H to F3FFH can be used as external memory by setting the internal PROM size to less than 56K bytes by the memory size switching register (IMS).

5.2 Processor Registers

The μ PD78054 and 78054Y subseries units incorporate the following processor registers.

5.2.1 Control registers

The control registers control the program sequence, statuses and stack memory. The control registers consist of a program counter (PC), a program status word (PSW) and a stack pointer (SP).

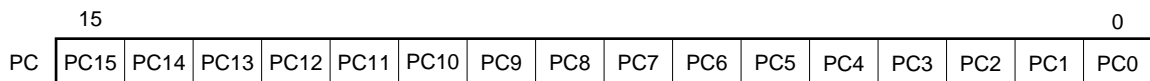
(1) Program counter (PC)

The program counter is a 16-bit register which holds the address information of the next program to be executed.

In normal operation, the PC is automatically incremented according to the number of bytes of the instruction to be fetched. When a branch instruction is executed, immediate data and register contents are set.

$\overline{\text{RESET}}$ input sets the reset vector table values at addresses 0000H and 0001H to the program counter.

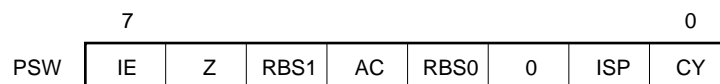
Figure 5-17. Program Counter Configuration



(2) Program status word (PSW)

The program status word is an 8-bit register consisting of various flags to be set/reset by instruction execution. Program status word contents are automatically stacked upon interrupt request generation or PUSH PSW instruction execution and are automatically reset upon execution of the RETB, RETI and POP PSW instructions. $\overline{\text{RESET}}$ input sets the PSW to 02H.

Figure 5-18. Program Status Word Configuration



(a) Interrupt enable flag (IE)

This flag controls the interrupt request acknowledge operations of the CPU.

When IE = 0, all interrupts except the non-maskable interrupt are disabled (DI status).

When IE = 1, interrupts are enabled (EI status). At this time, acknowledgment of interrupts is controlled with an inservice priority flag (ISP), an interrupt mask flag for various interrupt sources, and a priority specify flag.

The interrupt enable flag is reset to 0 when the DI instruction is executed or when an interrupt is acknowledged, and set to 1 when the EI instruction is executed.

(b) Zero flag (Z)

When the operation result is zero, this flag is set (1). It is reset (0) in all other cases.

(c) Register bank select flags (RBS0 and RBS1)

These are 2-bit flags to select one of the four register banks.

In these flags, the 2-bit information which indicates the register bank selected by SEL RBn instruction execution is stored.

(d) Auxiliary carry flag (AC)

If the operation result has a carry from bit 3 or a borrow at bit 3, this flag is set (1). It is reset (0) in all other cases.

(e) In-service priority flag (ISP)

This flag manages the priority of acknowledgeable maskable vectored interrupts. When $ISP = 0$, the vectored interrupt whose priority is specified by the priority specify flag registers (PR0L, PR0H, and PR1L) (Refer to **21.3 (3) Priority specify flag registers (PR0L, PR0H, and PR1L)**) to be low is disabled. Whether the interrupt is actually acknowledged is controlled by the status of the interrupt enable flag (IE).

(f) Carry flag (CY)

This flag stores overflow and underflow upon add/subtract instruction execution. It stores the shift-out value upon rotate instruction execution and functions as a bit accumulator during bit manipulation instruction execution.

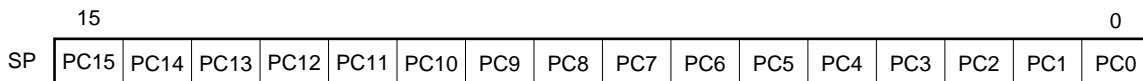
(3) Stack pointer (SP)

This is a 16-bit register to hold the start address of the memory stack area. Only the internal high-speed RAM area can be set as the stack area. The following shows the internal high-speed RAM area of each product.

Table 5-4. Internal High-Speed RAM Area

Part Number	Internal High-Speed RAM Area
μ PD78052, 78052Y	FD00H to FEFFH
μ PD78053, 78053Y	FB00H to FEFFH
μ PD78054, 78054Y	
μ PD78P054	
μ PD78055, 78055Y	
μ PD78056, 78056Y	
μ PD78058, 78058Y	
μ PD78P058, 78P058Y	

Figure 5-19. Stack Pointer Configuration



The SP is decremented ahead of write (save) to the stack memory and is incremented after read (reset) from the stack memory.

Each stack operation saves/resets data as shown in Figures 5-20 and 5-21.

Caution Since $\overline{\text{RESET}}$ input makes SP contents indeterminate, be sure to initialize the SP before instruction execution.

Figure 5-20. Data to be Saved to Stack Memory

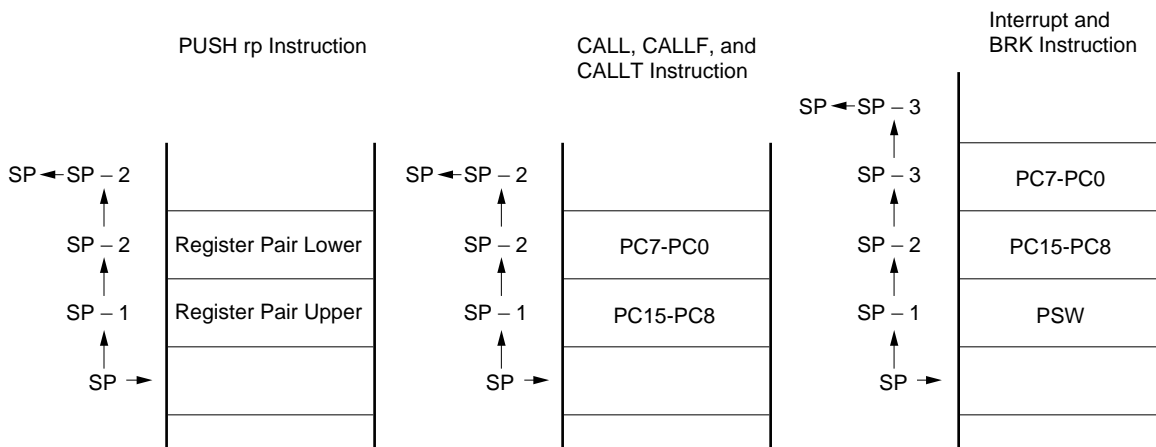
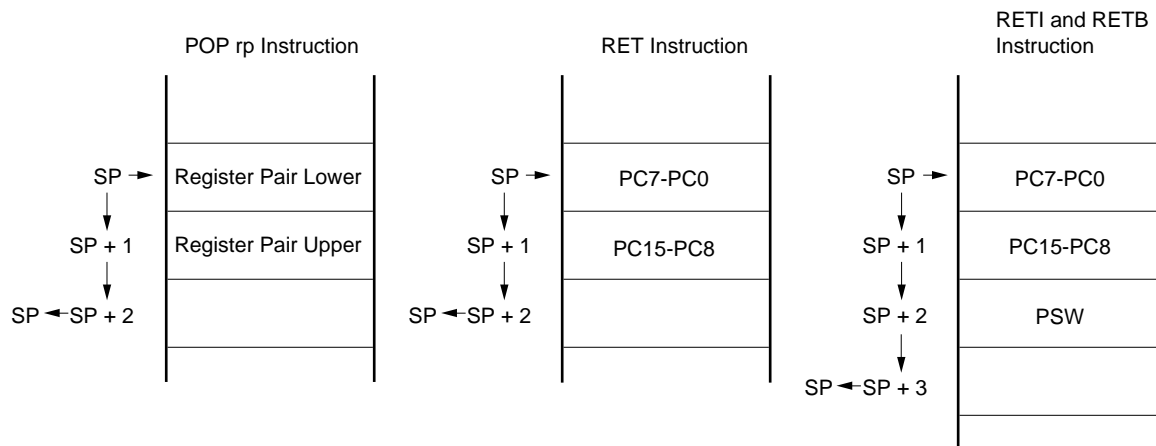


Figure 5-21. Data to be Reset from Stack Memory



5.2.2 General registers

A general register is mapped at particular addresses (FEE0H to FEFFH) of the data memory. It consists of 4 banks, each bank consisting of eight 8-bit registers (X, A, C, B, E, D, L and H).

Each register can also be used as an 8-bit register. Two 8-bit registers can be used in pairs as a 16-bit register (AX, BC, DE and HL).

They can be described in terms of function names (X, A, C, B, E, D, L, H, AX, BC, DE and HL) and absolute names (R0 to R7 and RP0 to RP3).

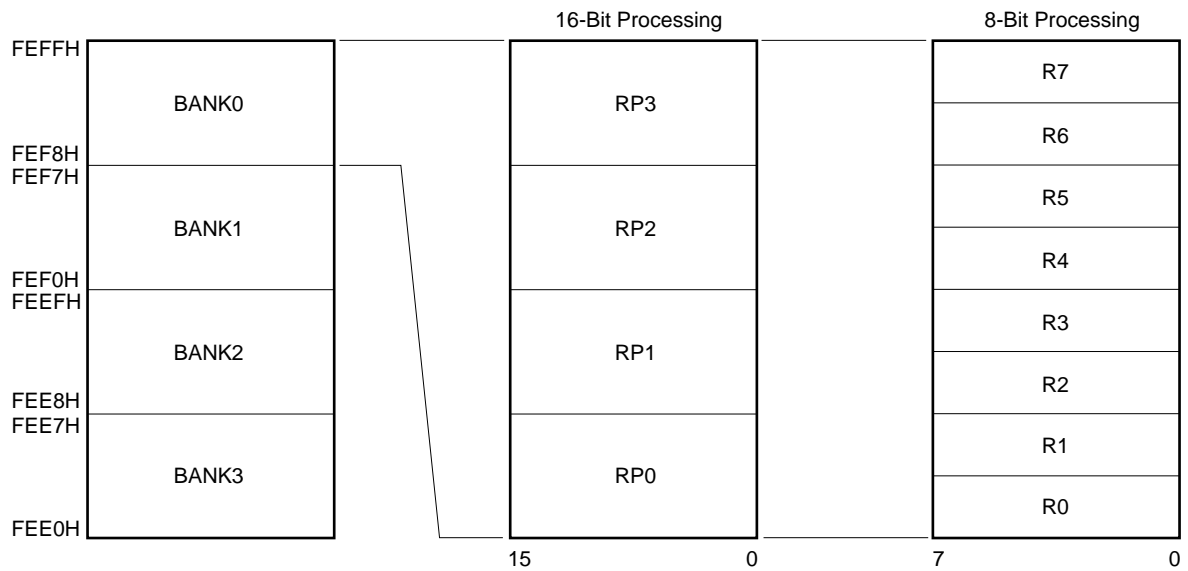
Register banks to be used for instruction execution are set with the CPU control instruction (SEL RbN). Because of the 4-register bank configuration, an efficient program can be created by switching between a register for normal processing and a register for interruption for each bank.

Table 5-5. Correspondent Table of Absolute Addresses in the General Registers

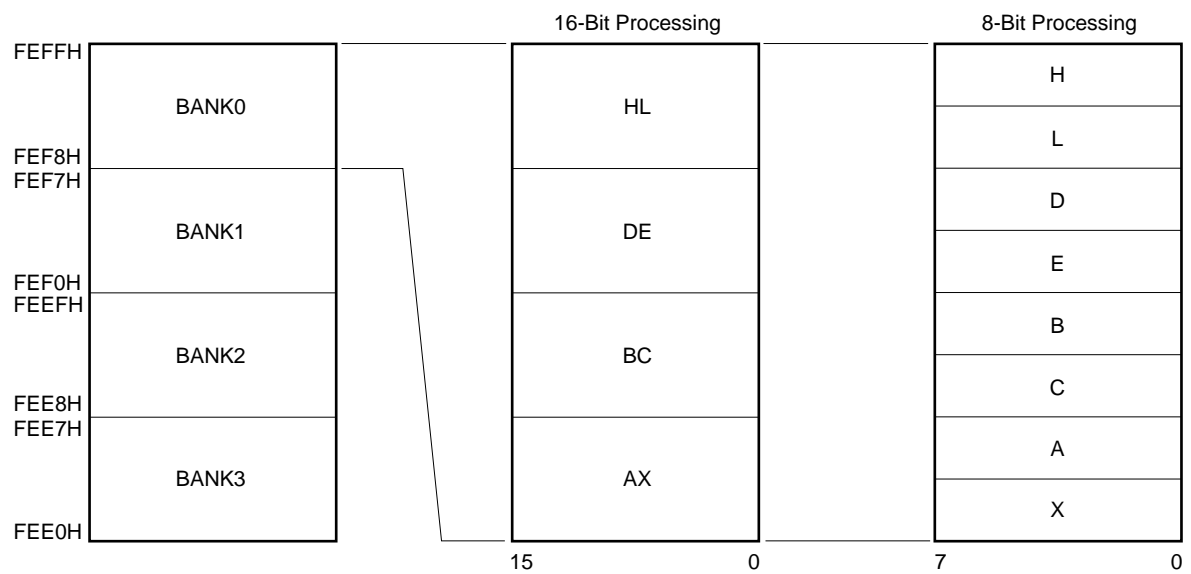
Bank	Register		Absolute Address	Bank	Register		Absolute Address
	Functional Name	Absolute Name			Functional Name	Absolute Name	
BANK0	H	R7	FEFFH	BANK2	H	R7	FEEFH
	L	R6	FEFEH		L	R6	FEEEH
	D	R5	FEFDH		D	R5	FEE DH
	E	R4	FEFCH		E	R4	FEECH
	B	R3	FEFBH		B	R3	FEEBH
	C	R2	FEFAH		C	R2	FEEAH
	A	R1	FEF9H		A	R1	FEE9H
	X	R0	FEF8H		X	R0	FEE8H
BANK1	H	R7	FEF7H	BANK3	H	R7	FEE7H
	L	R6	FEF6H		L	R6	FEE6H
	D	R5	FEF5H		D	R5	FEE5H
	E	R4	FEF4H		E	R4	FEE4H
	B	R3	FEF3H		B	R3	FEE3H
	C	R2	FEF2H		C	R2	FEE2H
	A	R1	FEF1H		A	R1	FEE1H
	X	R0	FEF0H		X	R0	FEE0H

Figure 5-22. General Register Configuration

(a) Absolute Name



(b) Function Name



5.2.3 Special Function Register (SFR)

Unlike a general register, each special-function register has special functions.

It is allocated in the FF00H to FFFFH area.

The special-function register can be manipulated like the general register, with the operation, transfer and bit manipulation instructions. Manipulatable bit units, 1, 8 and 16, depend on the special-function register type.

Each manipulation bit unit can be specified as follows.

- 1-bit manipulation
Describe the symbol reserved with assembler for the 1-bit manipulation instruction operand (sfr.bit).
This manipulation can also be specified with an address.
- 8-bit manipulation
Describe the symbol reserved with assembler for the 8-bit manipulation instruction operand (sfr).
This manipulation can also be specified with an address.
- 16-bit manipulation
Describe the symbol reserved with assembler for the 16-bit manipulation instruction operand (sfrp).
When addressing an address, describe an even address.

Table 5-6 gives a list of special-function registers. The meaning of items in the table is as follows.

- Symbol
- ★ Symbols indicating the addresses of special function register. These symbols are reserved words for the RA78K/0 and defined by header file **sfrbit.h** for the CC78K/0, and can be used as the operands of instructions when the RA78K/0, ID78K0-NS, ID78K0, and SM78K0 are used.
- R/W
Indicates whether the corresponding special-function register can be read or written.
R/W : Read/write enable
R : Read only
W : Write only
- Manipulatable bit units
√ indicates bit units (1, 8 or 16 bits) in which the register can be manipulated. — indicates that the register cannot be manipulated in the indicated bit units.
- After reset
Indicates each register status upon $\overline{\text{RESET}}$ input.

Table 5-6. Special-Function Register List (1/3)

Address	Special-Function Register (SFR) Name	Symbol		R/W	Manipulatable Bit Unit			After Reset
					1 bit	8 bits	16 bits	
FF00H	Port0	P0		R/W	√	√	—	00H
FF01H	Port1	P1			√	√	—	
FF02H	Port2	P2			√	√	—	
FF03H	Port3	P3			√	√	—	
FF04H	Port4	P4			√	√	—	Undefined
FF05H	Port5	P5			√	√	—	
FF06H	Port6	P6			√	√	—	
FF07H	Port7	P7			√	√	—	00H
FF0CH	Port12	P12			√	√	—	
FF0DH	Port13	P13			√	√	—	
FF10H FF11H	Capture/compare register 00	CR00			—	—	√	Undefined
FF12H FF13H	Capture/compare register 01	CR01			—	—	√	
FF14H FF15H	16-bit timer register	TM0			R	—	—	√
FF16H	Compare register 10	CR10		R/W	—	√	—	Undefined
FF17H	Compare register 20	CR20			—	√	—	
FF18H	8-bit timer register 1	TMS	TM1	R	—	√	√	00H
FF19H	8-bit timer register 2		TM2		—	√		
FF1AH	Serial I/O shift register 0	SIO0		R/W	—	√	—	Undefined
FF1BH	Serial I/O shift register 1	SIO1			—	√	—	
FF1FH	A/D conversion result register	ADCR		R	—	√	—	
FF20H	Port mode register 0	PM0		R/W	√	√	—	FFH
FF21H	Port mode register 1	PM1			√	√	—	
FF22H	Port mode register 2	PM2			√	√	—	
FF23H	Port mode register 3	PM3			√	√	—	
FF25H	Port mode register 5	PM5			√	√	—	
FF26H	Port mode register 6	PM6			√	√	—	
FF27H	Port mode register 7	PM7			√	√	—	
FF2CH	Port mode register 12	PM12			√	√	—	
FF2DH	Port mode register 13	PM13			√	√	—	
FF30H	Real-time output buffer register L	RTBL			—	√	—	
FF31H	Real-time output buffer register H	RTBH			—	√	—	
FF34H	Real-time output port mode register	RTPM			√	√	—	
FF36H	Real-time output port control register	RTPC			√	√	—	

Table 5-6. Special-Function Register List (2/3)

Address	Special-Function Register (SFR) Name	Symbol	R/W	Manipulatable Bit Unit			After Reset	
				1 bit	8 bits	16 bits		
FF38H FF39H	Correction address register 0 ^(Note)	CORAD0	R/W	—	—	√	0000H	
FF3AH FF3BH	Correction address register 1 ^(Note)	CORAD1		—	—	√		
FF40H	Timer clock select register 0	TCL0		√	√	—	00H	
FF41H	Timer clock select register 1	TCL1		—	√	—		
FF42H	Timer clock select register 2	TCL2		—	√	—	88H	
FF43H	Timer clock select register 3	TCL3		—	√	—		
FF47H	Sampling clock select register	SCS		—	√	—	00H	
FF48H	16-bit timer mode control register	TMC0		√	√	—	04H	
FF49H	8-bit timer mode control register 1	TMC1		√	√	—		
FF4AH	Watch timer mode control register	TMC2		√	√	—		
FF4CH	Capture/compare control register 0	CRC0		√	√	—	04H	
FF4EH	16-bit timer output control register	TOC0		√	√	—	00H	
FF4FH	8-bit timer output control register	TOC1		√	√	—		
FF60H	Serial operating mode register 0	CSIM0		√	√	—	Undefined	
FF61H	Serial bus interface control register	SBIC		√	√	—		
FF62H	Slave address register	SVA		—	√	—		
FF63H	Interrupt timing specify register	SINT		√	√	—	00H	
FF68H	Serial operating mode register 1	CSIM1		√	√	—		
FF69H	Automatic data transmit/receive control register	ADTC		√	√	—	00H	
FF6AH	Automatic data transmit/receive address pointer	ADTP		—	√	—		
FF6BH	Automatic data transmit/receive interval specify register	ADTI		√	√	—		
FF70H	Asynchronous serial interface mode register	ASIM		√	√	—	FFH	
FF71H	Asynchronous serial interface status register	ASIS		R	—	√		
FF72H	Serial operating mode register 2	CSIM2		RW	√	√	—	
FF73H	Baud rate generator control register	BRGC		RW	—	√	—	
FF74H	Transmit shift register	TXS		SIO2	W	—	√	—
	Receive buffer register	RXB						
FF80H	A/D converter mode register	ADM		R/W	√	√	—	01H
FF84H	A/D converter input select register	ADIS			—	√	—	00H
FF8AH	Correction control register ^(Note)	CORCN			√	√	—	
FF90H	D/A conversion value set register 0	DACS0	—		√	—	00H	
FF91H	D/A conversion value set register 1	DACS1	—		√	—		
FF98H	D/A converter mode register	DAM	√		√	—		

Note This register is provided only in the μ PD78058, 78P058, 78058Y and 78P058Y.

Table 5-6. Special-Function Register List (3/3)

Address	Special-Function Register (SFR) Name	Symbol		R/W	Manipulatable Bit Unit			After Reset
					1 bit	8 bits	16 bits	
FFD0H to FFD0H	External access area ^{Note1}			R/W	√	√	—	Undefined
FFE0H	Interrupt request flag register 0L	IF0	IF0L	R/W	√	√	√	00H
FFE1H	Interrupt request flag register 0H		IF0H		√	√		
FFE2H	Interrupt request flag register 1L	IF1L	√		√	—		
FFE4H	Interrupt mask flag register 0L	MK0	MK0L		√	√	√	FFH
FFE5H	Interrupt mask flag register 0H		MK0H		√	√		
FFE6H	Interrupt mask flag register 1L	MK1L	√		√	—		
FFE8H	Priority order specify flag register 0L	PR0	PR0L		√	√	√	00H
FFE9H	Priority order specify flag register 0H		PR0H		√	√		
FFEAH	Priority order specify flag register 1L	PR1L	√		√	—		
FFECH	External interrupt mode register 0	INTM0	—		√	—		
FFEDH	External interrupt mode register 1	INTM1	—	√	—			
FFF0H	Memory size switching register	IMS	—	√	—	Note2		
FFF2H	Oscillation mode selection register	OSMS	W	—	√	—	00H	
FFF3H	Pull-up resistor option register H	PUOH	R/W	√	√	—		
FFF4H	Internal expansion RAM size switching register ^{Note3}	IXS	W	—	√	—	0AH	
FFF6H	Key return mode register	KRM	R/W	√	√	—	02H	
FFF7H	Pull-up resistor option register L	PUOL		√	√	—	00H	
FFF8H	Memory expansion mode register	MM		√	√	—	10H	
FFF9H	Watchdog timer mode register	WDTM		√	√	—	00H	
FFFAH	Oscillation stabilization time select register	OSTS		—	√	—	04H	
FFFBH	Processor clock control register	PCC		√	√	—		

- Notes**
1. The external access area cannot be accessed in SFR addressing. Access the area with direct addressing.
 2. The value after reset depends on products.
 μ PD78052, 78052Y: 44H, μ PD78053, 78053Y: C6H, μ PD78054, 78054Y: C8H, μ PD78P054: C8H, μ PD78055, 78055Y: CAH, μ PD78056, 78056Y: CCH, μ PD78058, 78058Y: CFH, μ PD78P058, 78P058Y: CFH
 3. This register is provided only in the μ PD78058, 78058Y, 78P058, and 78P058Y.

5.3 Instruction Address Addressing

An instruction address is determined by program counter (PC) contents. The contents of PC are normally incremented (+1 for each byte) automatically according to the number of bytes of an instruction to be fetched each time another instruction is executed. When a branch instruction is executed, the branch destination information is set to the PC and branched by the following addressing. (For details of instructions, refer to **78K/0 Series User's Manual, Instruction (U12326E)**).

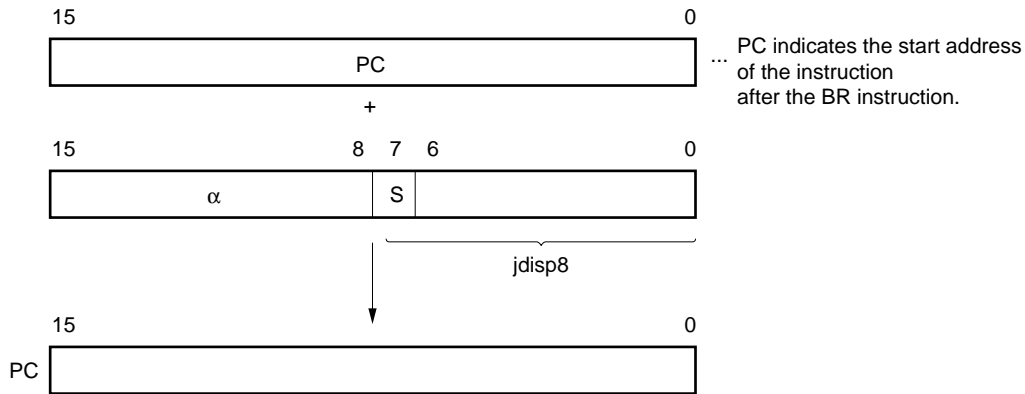
5.3.1 Relative addressing

[Function]

The value obtained by adding 8-bit immediate data (displacement value: *jdisp8*) of an instruction code to the start address of the following instruction is transferred to the program counter (PC) and branched. The displacement value is treated as signed two's complement data (−128 to +127) and bit 7 becomes a sign bit. In the relative addressing modes, execution branches in a relative range of −128 to +127 from the first address of the next instruction.

This function is carried out when the BR \$addr16 instruction or a conditional branch instruction is executed.

[Illustration]



When S = 0, all bits of *α* are 0.
 When S = 1, all bits of *α* are 1.

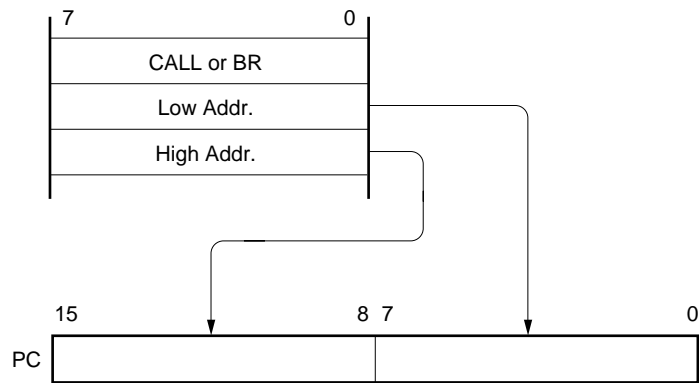
5.3.2 Immediate addressing

[Function]

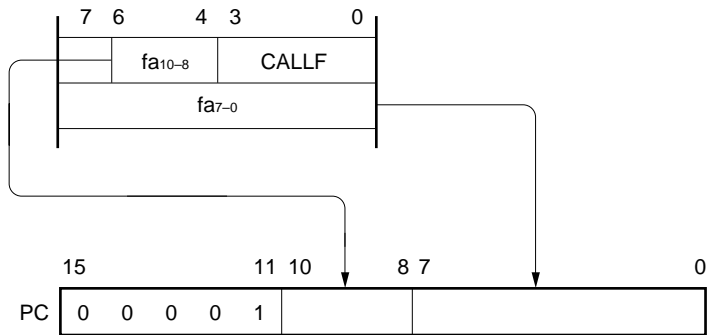
Immediate data in the instruction word is transferred to the program counter (PC) and branched. This function is carried out when the CALL !addr16 or BR !addr16 or CALLF !addr11 instruction is executed. The CALL !addr16 and BR !addr16 instruction can branch in the entire memory space. The CALLF !addr11 instruction branches to an area of addresses 0800H through 0FFFH.

[Illustration]

In the case of CALL !addr16 and BR !addr16 instructions



In the case of CALLF !addr11 instruction



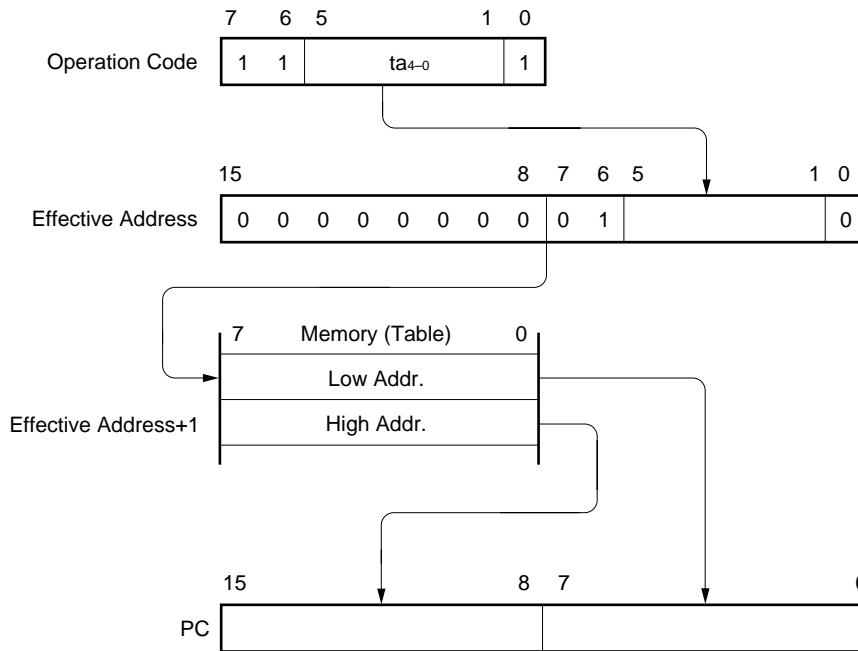
5.3.3 Table indirect addressing

[Function]

Table contents (branch destination address) of the particular location to be addressed by bits 1 to 5 of the immediate data of an operation code are transferred to the program counter (PC) and branched.

Before the CALLT [addr5] instruction is executed, table indirect addressing is performed. This instruction references an address stored in the memory table at addresses 40H through 7FH, and can branch in the entire memory space.

[Illustration]



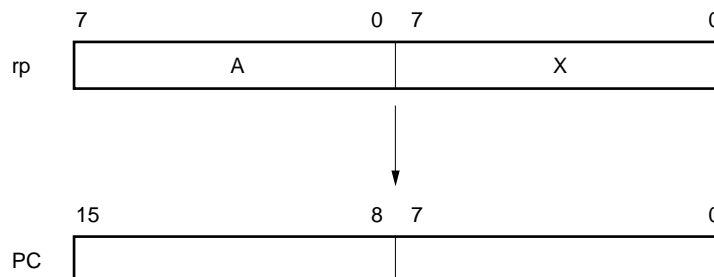
5.3.4 Register addressing

[Function]

Register pair (AX) contents to be specified with an instruction word are transferred to the program counter (PC) and branched.

This function is carried out when the BR AX instruction is executed.

[Illustration]



5.4 Operand Address Addressing

The following various methods are available to specify the register and memory (addressing) which undergo manipulation during instruction execution.

5.4.1 Implied addressing

[Function]

The register which functions as an accumulator (A and AX) in the general register is automatically (illicitly) addressed.

Of the μ PD78054 and 78054Y subseries instruction words, the following instructions employ implied addressing.

Instruction	Register to be Specified by Implied Addressing
MULU	A register for multiplicand and AX register for product storage
DIVUW	AX register for dividend and quotient storage
ADJBA/ADJBS	A register for storage of numeric values which become decimal correction targets
ROR4/ROL4	A register for storage of digit data which undergoes digit rotation

[Operand format]

Because implied addressing can be automatically employed with an instruction, no particular operand format is necessary.

[Description example]

In the case of MULU X

With an 8-bit \times 8-bit multiply instruction, the product of A register and X register is stored in AX. In this example, the A and AX registers are specified by implied addressing.

5.4.2 Register addressing

[Function]

This addressing accesses a general register as an operand. The general register accessed is specified by the register bank select flags (RBS0 and RBS1) and register specify code (Rn or RPN) in an instruction code. Register addressing is carried out when an instruction with the following operand format is executed. When an 8-bit register is specified, one of the eight registers is specified with 3 bits in the operation code.

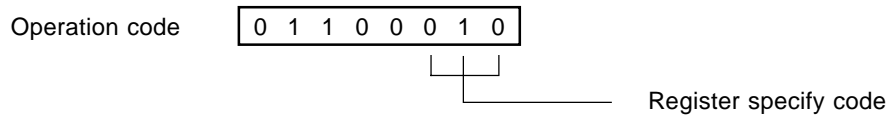
[Operand format]

Identifier	Description
r	X, A, C, B, E, D, L, H
rp	AX, BC, DE, HL

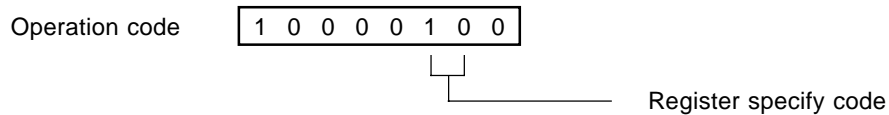
'r' and 'rp' can be described with function names (X, A, C, B, E, D, L, H, AX, BC, DE and HL) as well as absolute names (R0 to R7 and RP0 to RP3).

[Description example]

MOV A, C; when selecting C register as r



INCW DE; when selecting DE register pair as rp



5.4.3 Direct addressing

[Function]

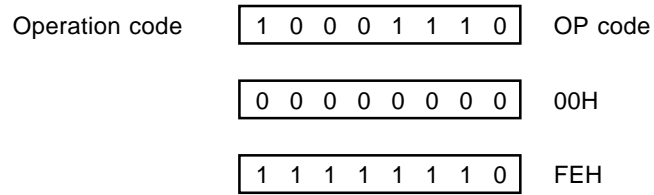
This addressing directly addresses the memory indicated by the immediate data in an instruction word.

[Operand format]

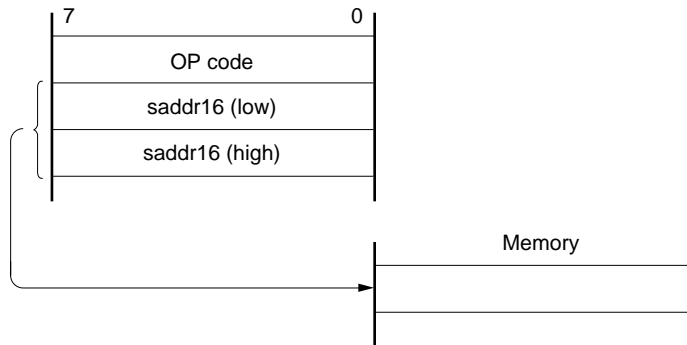
Identifier	Description
addr16	Label or 16-bit immediate data

[Description example]

MOV A, !0FE00H; when setting !addr16 to FE00H



[Illustration]



5.4.4 Short direct addressing

[Function]

The memory to be manipulated in the fixed space is directly addressed with 8-bit data in an instruction word. The fixed space to which this address is applied is a 256-byte space of addresses FE20H through FF1FH. An internal high-speed RAM and a special-function register (SFR) are mapped at FE20H to FEFFH and FF00H to FF1FH, respectively.

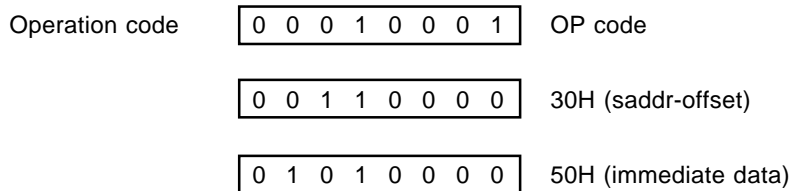
The SFR area (FF00H through FF1FH) to which short direct addressing is applied is a part of the entire SFR area. To this area, ports frequently accessed by the program, and the compare registers and capture registers of timer/event counters are mapped. These SFRs can be manipulated with a short byte length and a few clocks. When 8-bit immediate data is at 20H to FFH, bit 8 of an effective address is set to 0. When it is at 00H to 1FH, bit 8 is set to 1. Refer to [Illustration] on next page.

[Operand format]

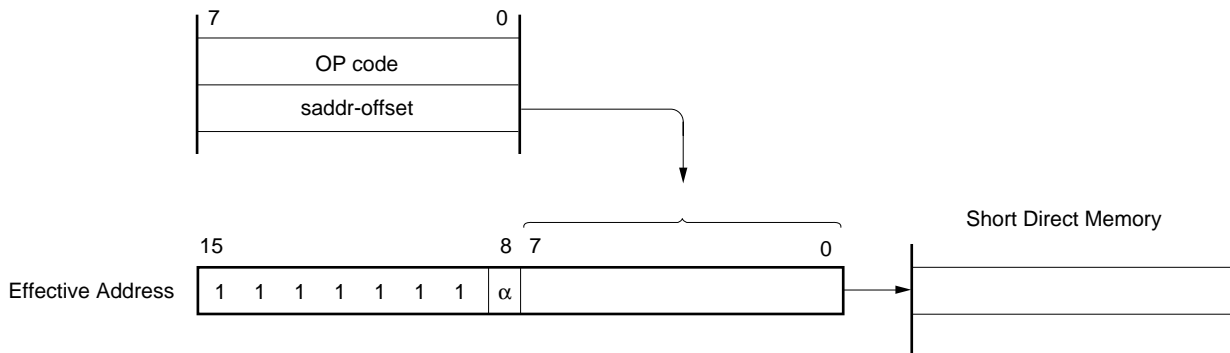
Identifier	Description
saddr	Label of FE20H to FF1FH immediate data
saddrp	Label of FE20H to FF1FH immediate data (even address only)

[Description example]

MOV 0FE30H, #50H; when setting saddr to FE30H and immediate data to 50H



[Illustration]



When 8-bit immediate data is 20H to FFH, $\alpha = 0$
 When 8-bit immediate data is 00H to 1FH, $\alpha = 1$

5.4.6 Register indirect addressing

[Function]

This addressing addresses the memory with the contents of a register pair specified as an operand. The register pair to be accessed is specified by the register bank select flags (RBS0 and RBS1) and register pair specify code in an instruction code. This addressing can be carried out for all the memory spaces.

[Operand format]

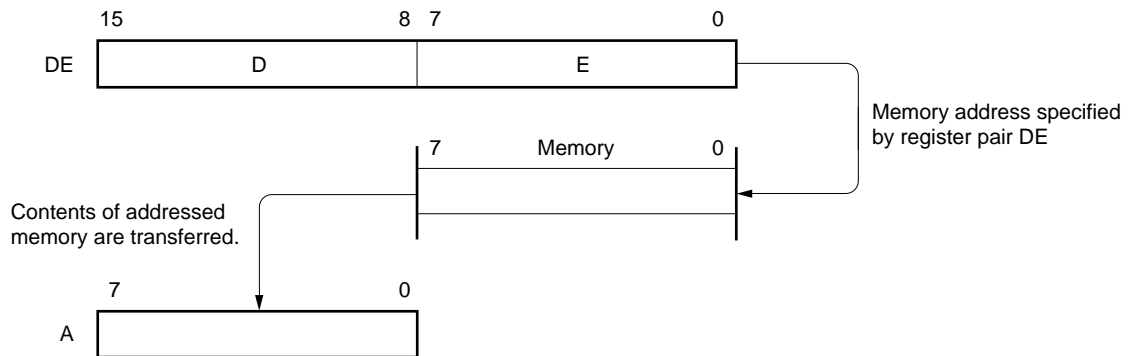
Identifier	Description
—	[DE], [HL]

[Description example]

MOV A, [DE]; when selecting [DE] as register pair

Operation code 1 0 0 0 0 1 0 1

[Illustration]



5.4.7 Based addressing

[Function]

This addressing addresses the memory by adding 8-bit immediate data to the contents of the HL register pair which is used as a base register and by using the result of the addition. The HL register pair to be accessed is in the register bank specified by the register bank select flags (RBS0 and RBS1). Addition is performed by expanding the offset data as a positive number to 16 bits. A carry from the 16th bit is ignored. This addressing can be carried out for all the memory spaces.

[Operand format]

Identifier	Description
—	[HL + byte]

[Description example]

MOV A, [HL + 10H]; when setting byte to 10H

Operation code

1	0	1	0	1	1	1	0
---	---	---	---	---	---	---	---

0	0	0	1	0	0	0	0
---	---	---	---	---	---	---	---

5.4.8 Based indexed addressing

[Function]

This addressing addresses the memory by adding the contents of the HL register, which is used as a base register, to the contents of the B or C register specified in the instruction word, and by using the result of the addition. The HL, B, and C registers to be accessed are registers in the register bank specified by the register bank select flags (RBS0 and RBS1). The addition is performed by extending the contents of the B or C register to 16 bits as a positive number. A carry from the 16th bit is ignored. This addressing can be carried out for all the memory spaces.

[Operand format]

Identifier	Description
—	[HL + B], [HL + C]

[Description example]

In the case of MOV A, [HL + B]

Operation code

1	0	1	0	1	0	1	1
---	---	---	---	---	---	---	---

5.4.9 Stack addressing

[Function]

The stack area is indirectly addressed with the stack pointer (SP) contents. This addressing method is automatically employed when the PUSH, POP, subroutine call and RETURN instructions are executed or the register is saved/reset upon generation of an interrupt request. Stack addressing enables to address the internal high-speed RAM area only.

[Description example]

In the case of PUSH DE

Operation code

1	0	1	1	0	1	0	1
---	---	---	---	---	---	---	---

CHAPTER 6 PORT FUNCTIONS

6.1 Port Functions

The μ PD78054 and 78054Y subseries units incorporate two input ports and sixty-seven input/output ports. Figure 6-1 shows the port configuration. Every port is capable of 1-bit and 8-bit manipulations and can carry out considerably varied control operations. Besides port functions, the ports can also serve as on-chip hardware input/output pins.

Figure 6-1. Port Types

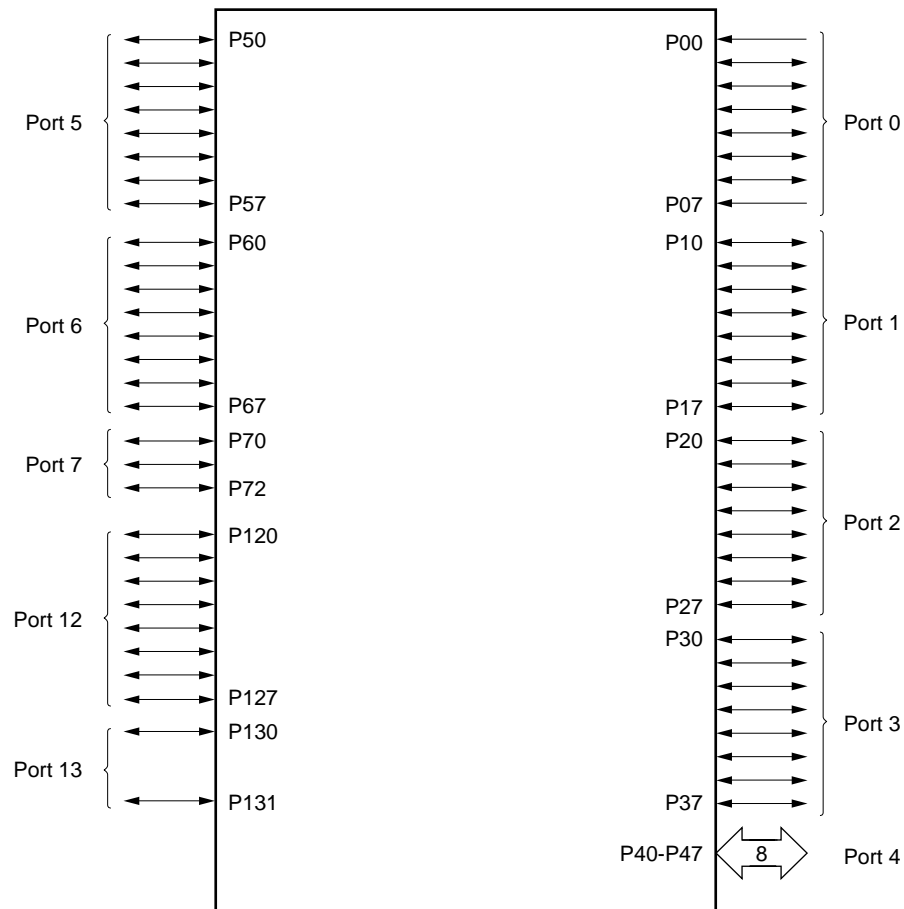


Table 6-1. Port Functions (μ PD78054 subseries) (1/2)

Pin Name	Function	Alternate Function	
P00	Port 0. 8-bit input/output port.	Input only	
P01		INTP0/TI00	
P02		Input/output mode can be specified in 1-bit units. When used as an input port, an on-chip pull-up resistor can be used by software.	INTP1/TI01
P03			INTP2
P04			INTP3
P05			INTP4
P06		INTP5	
P07		Input only	INTP6
P10 to P17	Port 1. 8-bit input/output port. Input/output mode can be specified in 1-bit units. When used as an input port, an on-chip pull-up resistor can be used by software.	XT1	
P20	Port 2. 8-bit input/output port. Input/output mode can be specified in 1-bit units. When used as an input port, an on-chip pull-up resistor can be used by software.	ANI0 to ANI7	
P21		SI1	
P22		SO1	
P23		SCK1	
P24		STB	
P25		BUSY	
P26		SI0/SB0	
P27		SO0/SB1	
P30	Port 3. 8-bit input/output port. Input/output mode can be specified in 1-bit units. When used as an input port, an on-chip pull-up resistor can be used by software.	SCK0	
P31		TO0	
P32		TO1	
P33		TO2	
P34		TI1	
P35		TI2	
P36		PCL	
P37		BUZ	
P40 to P47	Port 4. 8-bit input/output port. Input/output mode can be specified in 8-bit units. When used as an input port, an on-chip pull-up resistor can be used by software. Test input flag (KRIF) is set to 1 by falling edge detection.	—	
P50 to P57	Port 5. 8-bit input/output port. LED can be driven directly. Input/output mode can be specified in 1-bit units. When used as an input port, an on-chip pull-up resistor can be used by software.	AD0 to AD7	
		A8 to A15	

Table 6-1. Port Functions (μ PD78054 subseries) (2/2)

Pin Name	Function		Alternate Function	
P60	Port 6. 8-bit input/output port. Input/output mode can be specified in 1-bit units.	N-ch open-drain input/output port.	—	
P61		On-chip pull-up resistor can be specified by mask option. (Mask ROM version only).		
P62		LEDs can be driven directly.		
P63		When used as an input port, an on-chip pull-up resistor can be used by software.		
P64				\overline{RD}
P65				\overline{WR}
P66				\overline{WAIT}
P67				ASTB
P70	Port 7. 3-bit input/output port.		SI2/RxD	
P71	Input/output mode can be specified in 1-bit units.		SO2/TxD	
P72	When used as an input port, an on-chip pull-up resistor can be used by software.		$\overline{SCK2/ASCK}$	
P120 to P127	Port 12. 8-bit input/output port. Input/output mode can be specified in 1-bit units. When used as an input port, on-chip pull-up resistor can be used by software.		RTP0 to RTP7	
P130 and P131	Port 13. 2-bit input/output port. Input/output mode can be specified in 1-bit units. When used as an input port, on-chip pull-up resistor can be used by software.		ANO0, ANO1	

Table 6-2. Port Functions (μ PD78054Y subseries) (1/2)

Pin Name	Function	Alternate Function	
P00	Port 0. 8-bit input/output port.	Input only	
P01		INTP0/TI00	
P02		Input/output mode can be specified in 1-bit units. When used as an input port, an on-chip pull-up resistor can be used by software.	INTP1/TI01
P03			INTP2
P04			INTP3
P05			INTP4
P06		INTP5	
P07		INTP6	
P07	Input only	XT1	
P10 to P17	Port 1. 8-bit input/output port. Input/output mode can be specified in 1-bit units. When used as an input port, an on-chip pull-up resistor can be used by software.	ANI0 to ANI7	
P20	Port 2. 8-bit input/output port. Input/output mode can be specified in 1-bit units. When used as an input port, an on-chip pull-up resistor can be used by software.	SI1	
P21		SO1	
P22		SCK1	
P23		STB	
P24		BUSY	
P25		SI0/SB0/SDA0	
P26		SO0/SB1/SDA1	
P27		SCK0/SCL	
P30	Port 3. 8-bit input/output port. Input/output mode can be specified in 1-bit units. When used as an input port, an on-chip pull-up resistor can be used by software.	TO0	
P31		TO1	
P32		TO2	
P33		TI1	
P34		TI2	
P35		PCL	
P36		BUZ	
P37		—	
P40 to P47	Port 4. 8-bit input/output port. Input/output mode can be specified in 8-bit units. When used as an input port, an on-chip pull-up resistor can be used by software. Test input flag (KRIF) is set to 1 by falling edge detection.	AD0 to AD7	
P50 to P57	Port 5. 8-bit input/output port. LED can be driven directly. Input/output mode can be specified in 1-bit units. When used as an input port, an on-chip pull-up resistor can be used by software.	A8 to A15	

Table 6-2. Port Functions (μ PD78054Y subseries) (2/2)

Pin Name	Function		Alternate Function	
P60	Port 6. 8-bit input/output port. Input/output mode can be specified in 1-bit units.	N-ch open drain input/output port.	—	
P61		On-chip pull-up resistor can be specified by mask option. (Mask ROM version only).		
P62		LEDs can be driven directly.		
P63		When used as an input port, an on-chip pull-up resistor can be used by software.		
P64				\overline{RD}
P65				\overline{WR}
P66				\overline{WAIT}
P67				ASTB
P70	Port 7. 3-bit input/output port.		SI2/RxD	
P71	Input/output mode can be specified in 1-bit units.		SO2/TxD	
P72	When used as an input port, an on-chip pull-up resistor can be used by software.		$\overline{SCK2/ASCK}$	
P120 to P127	Port 12. 8-bit input/output port. Input/output mode can be specified in 1-bit units. When used as an input port, on-chip pull-up resistor can be used by software.		RTP0 to RTP7	
P130 and P131	Port 13. 2-bit input/output port. Input/output mode can be specified in 1-bit units. When used as an input port, on-chip pull-up resistor can be used by software.		ANO0, ANO1	

6.2 Port Configuration

A port consists of the following hardware:

Table 6-3. Port Configuration

Item	Configuration
Control register	Port mode register (PM _m : m = 0 to 3, 5 to 10, 12, 13) Pull-up resistor option register (PUOH, PUOL) Memory expansion mode register (MM) ^{Note} Key return mode register (KRM)
Port	Total: 69 ports (2 inputs, 67 inputs/outputs)
Pull-up resistor	<ul style="list-style-type: none"> • Mask ROM version Total: 67 (software specifiable: 63, mask option: 4) • PROM version Total: 63

Note MM specifies port 4 input/output.

6.2.1 Port 0

Port 0 is an 8-bit input/output port with output latch. P01 to P06 pins can specify the input mode/output mode in 1-bit units with the port mode register 0 (PM0). P00 and P07 pins are input-only ports. When P01 to P06 pins are used as input ports, an on-chip pull-up resistor can be used to them in 6-bit units with a pull-up resistor option register L (PUOL).

Alternate functions include external interrupt request input, external count clock input to the timer and crystal connection for subsystem clock oscillation.

$\overline{\text{RESET}}$ input sets port 0 to input mode.

Figures 6-2 and 6-3 show block diagrams of port 0.

Caution Because port 0 also serves for external interrupt request input, when the port function output mode is specified and the output level is changed, the interrupt request flag is set. Thus, when the output mode is used, set the interrupt mask flag to 1.

Figure 6-2. P00 and P07 Block Diagram

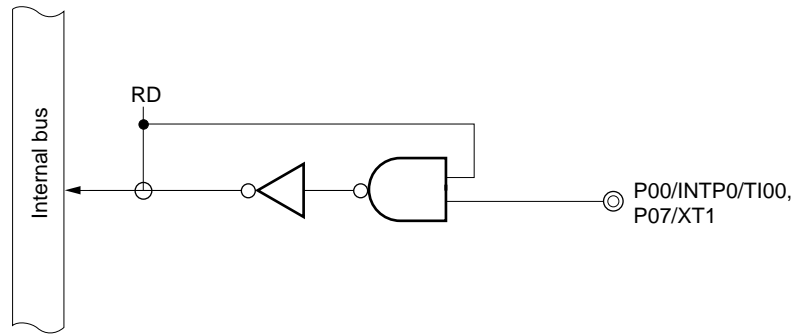
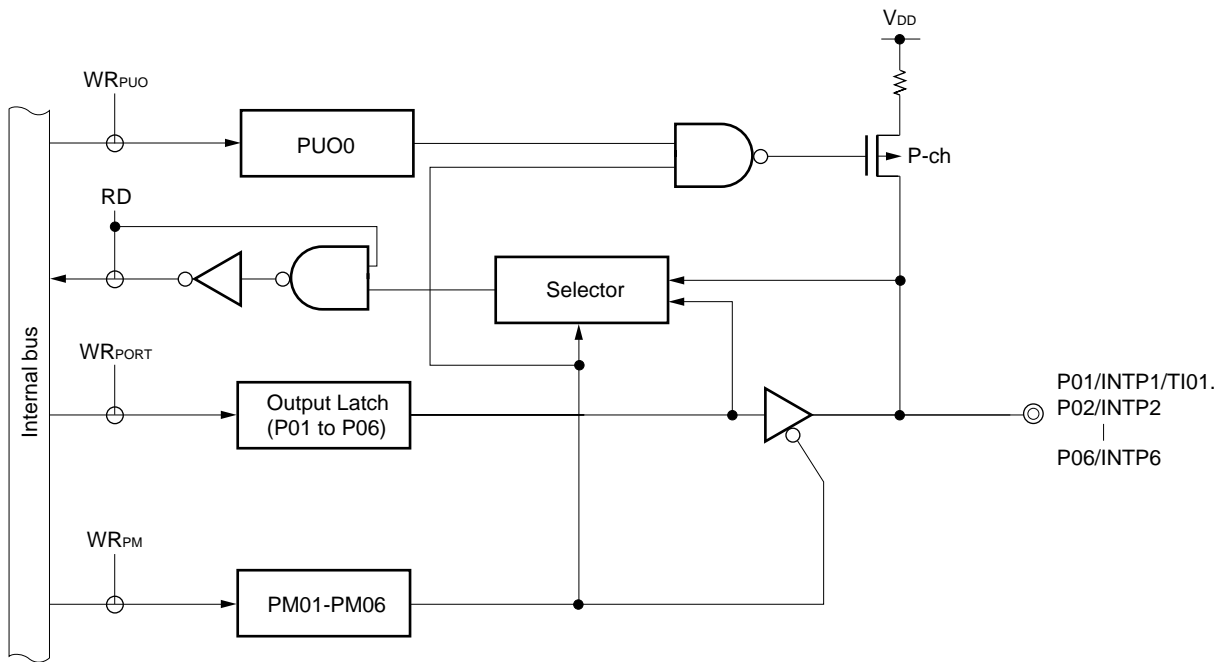


Figure 6-3. P01 to P06 Block Diagram



- PUO : Pull-up resistor option register
- PM : Port mode register
- RD : Port 0 read signal
- WR : Port 0 write signal

6.2.2 Port 1

Port 1 is an 8-bit input/output port with output latch. It can specify the input mode/output mode in 1-bit units with a port mode register 1 (PM1). When P10 to P17 pins are used as input ports, an on-chip pull-up resistor can be used to them in 8-bit units with a pull-up resistor option register L (PUOL).

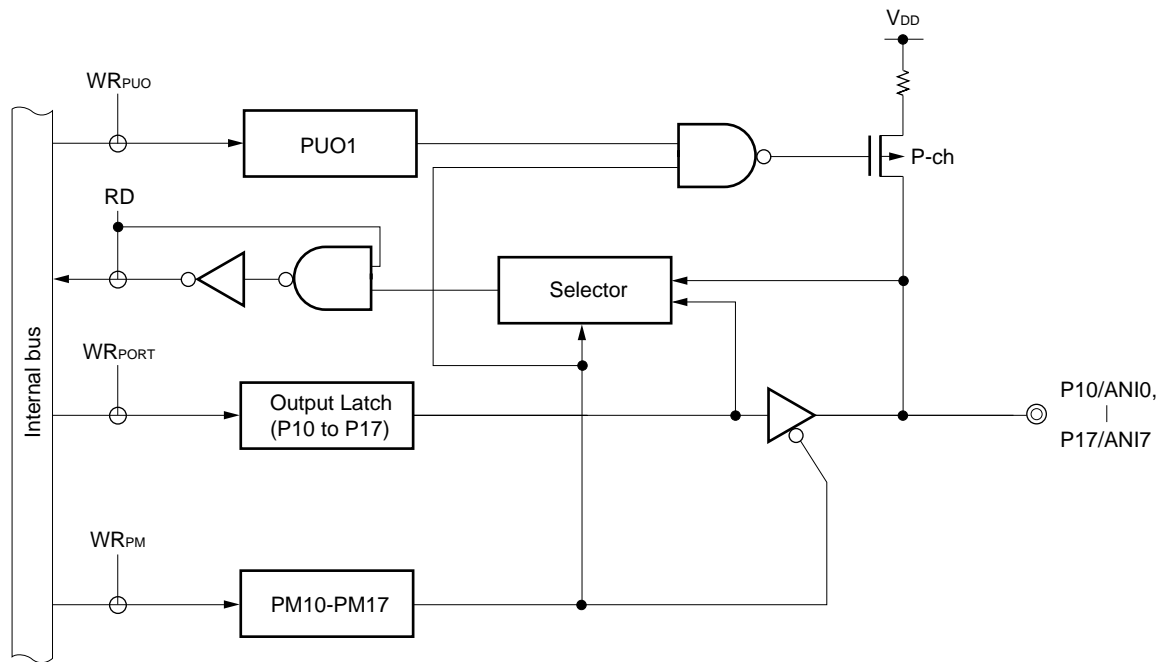
Alternate functions include an A/D converter analog input.

$\overline{\text{RESET}}$ input sets port 1 to input mode.

Figure 6-4 shows a block diagram of port 1.

Caution A pull-up resistor cannot be used for pins used as A/D converter analog input.

Figure 6-4. P10 to P17 Block Diagram



- PUO : Pull-up resistor option register
- PM : Port mode register
- RD : Port 1 read signal
- WR : Port 1 write signal

6.2.3 Port 2 (μ PD78054 Subseries)

Port 2 is an 8-bit input/output port with output latch. P20 to P27 pins can specify the input mode/output mode in 1-bit units with the port mode register 2 (PM2). When P20 to P27 pins are used as input ports, an on-chip pull-up resistor can be used to them in 8-bit units with a pull-up resistor option register L (PUOL).

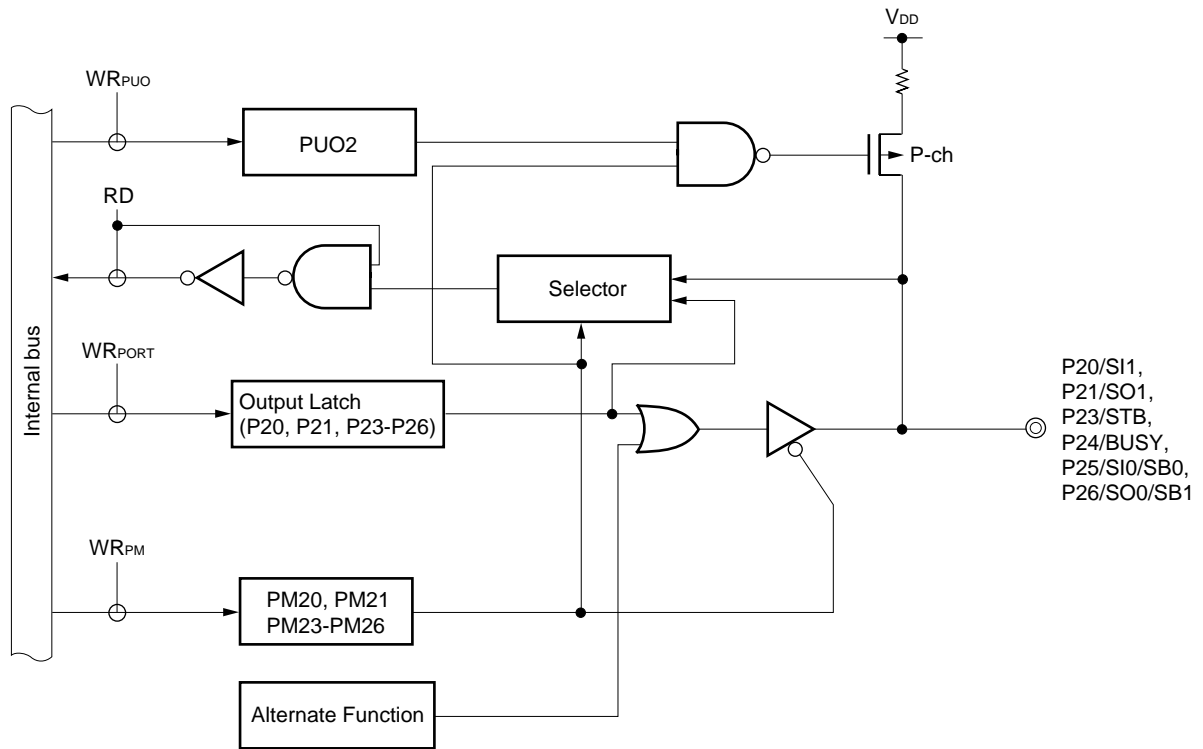
Alternate functions include serial interface data input/output, clock input/output, automatic transmit/receive busy input, and strobe output.

$\overline{\text{RESET}}$ input sets port 2 to input mode.

Figures 6-5 and 6-6 show block diagrams of port 2.

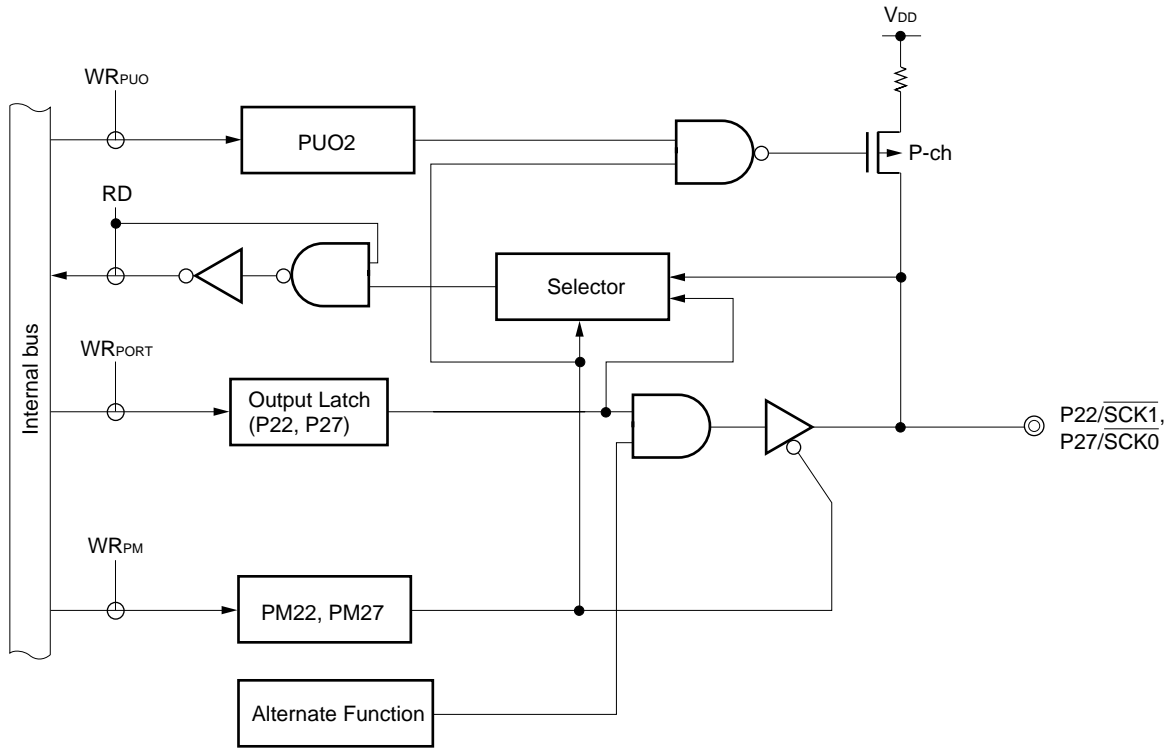
- Cautions 1.** When used as a serial interface, set the input/output and output latch according to its functions. For the setting method, refer to Figure 16-4 Serial Operating Mode Register 0 Format and Figure 18-3 Serial Operating Mode Register 1 Format.
- 2.** When reading the pin state in SBI mode, set PM2n bit of PM2 to 1 (n = 5, 6) (Refer to the description of (10) Discrimination of slave busy state in section 16.4.3 “SBI Mode Operation”).

Figure 6-5. P20, P21, P23 to P26 Block Diagram



- PUO : Pull-up resistor option register
- PM : Port mode register
- RD : Port 2 read signal
- WR : Port 2 write signal

Figure 6-6. P22 and P27 Block Diagram



- PUO : Pull-up resistor option register
- PM : Port mode register
- RD : Port 2 read signal
- WR : Port 2 write signal

6.2.4 Port 2 (μ PD78054Y Subseries)

Port 2 is an 8-bit input/output port with output latch. P20 to P27 pins can specify the input mode/output mode in 1-bit units with the port mode register 2 (PM2). When P20 to P27 pins are used as input ports, an on-chip pull-up resistor can be used to them in 8-bit units with a pull-up resistor option register L (PUOL).

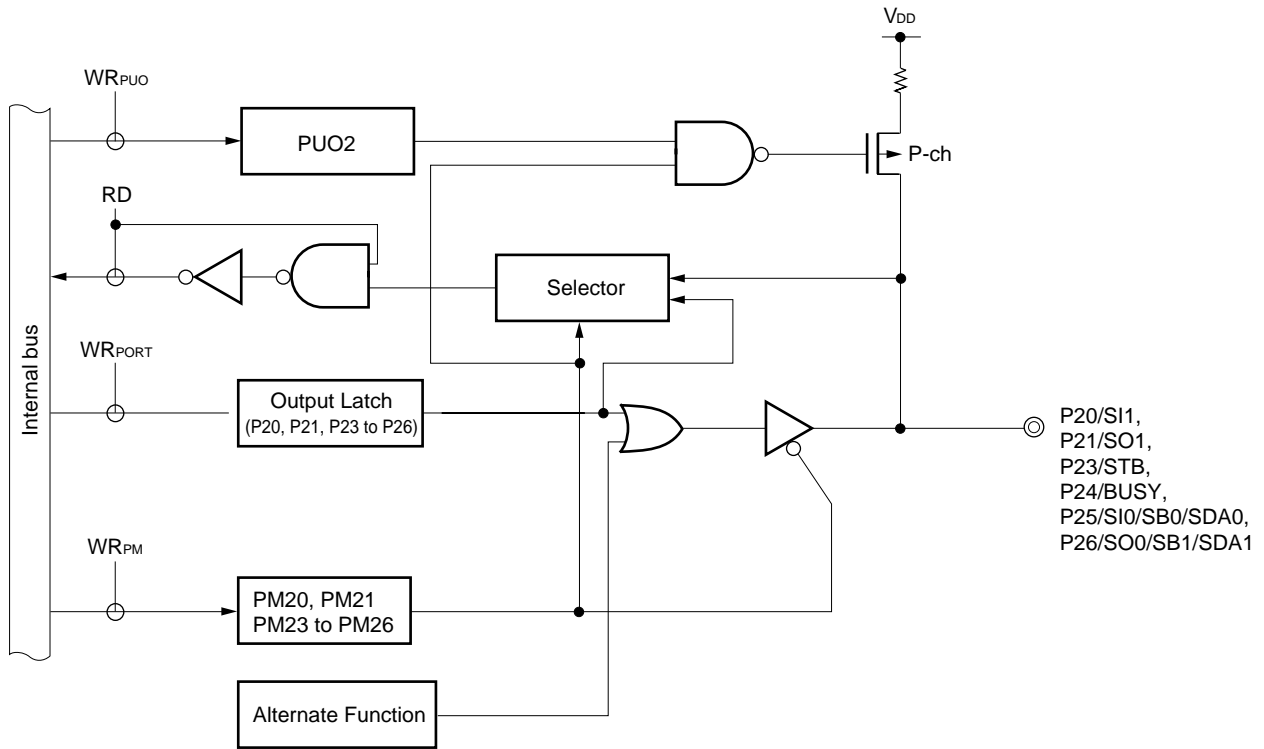
Alternate functions include serial interface data input/output, clock input/output, automatic transmit/receive busy input, and strobe output.

$\overline{\text{RESET}}$ input sets port 2 to input mode.

Figures 6-7 and 6-8 show block diagrams of port 2.

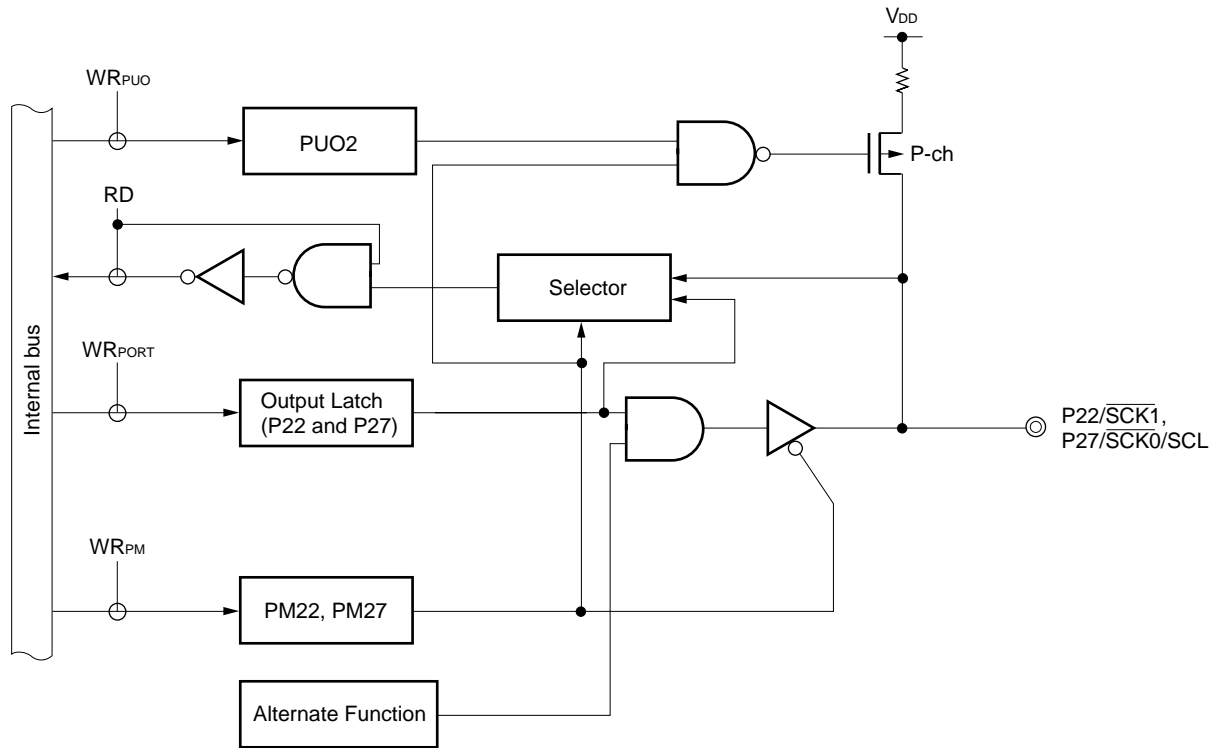
Caution When used as a serial interface, set the input/output and output latch according to its functions. For the setting method, refer to Figure 17-4 Serial Operating Mode Register 0 Format and Figure 18-3 Serial Operating Mode Register 1 Format.

Figure 6-7. P20, P21, P23 to P26 Block Diagram



- PUO : Pull-up resistor option register
- PM : Port mode register
- RD : Port 2 read signal
- WR : Port 2 write signal

Figure 6-8. P22 and P27 Block Diagram



- PUO : Pull-up resistor option register
- PM : Port mode register
- RD : Port 2 read signal
- WR : Port 2 write signal

6.2.5 Port 3

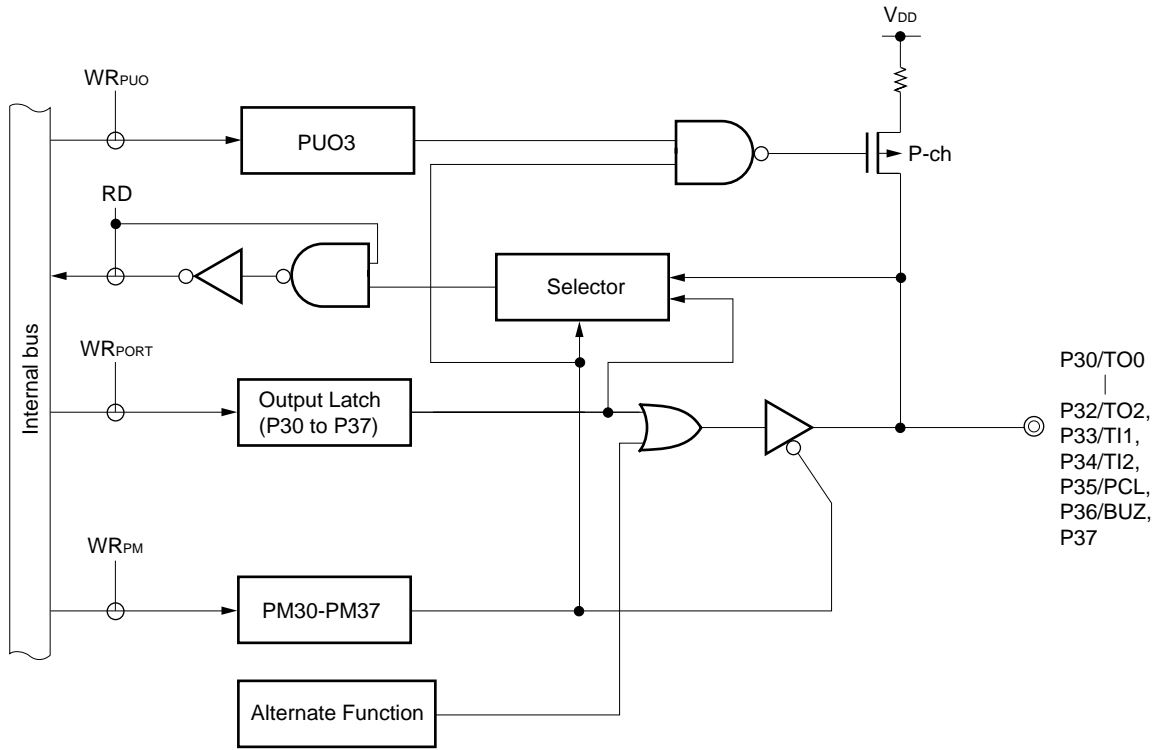
Port 3 is an 8-bit input/output port with output latch. P30 to P37 pins can specify the input mode/output mode in 1-bit units with the port mode register 3 (PM3). When P30 to P37 pins are used as input ports, an on-chip pull-up resistor can be used to them in 8-bit units with a pull-up resistor option register L (PUOL).

Alternate functions include timer input/output, clock output and buzzer output.

$\overline{\text{RESET}}$ input sets port 3 to input mode.

Figure 6-9 shows a block diagram of port 3.

Figure 6-9. P30 to P37 Block Diagram



- PUO : Pull-up resistor option register
- PM : Port mode register
- RD : Port 3 read signal
- WR : Port 3 write signal

6.2.6 Port 4

Port 4 is an 8-bit input/output port with output latch. P40 to P47 pins can specify the input mode/output mode in 8-bit units with the memory expansion mode register (MM). When P40 to P47 pins are used as input ports, an on-chip pull-up resistor can be used to them in 8-bit units with pull-up resistor option register L (PUOL).

The test input flag (KRIF) can be set to 1 by detecting falling edges.

Alternate function includes address/data bus function in external memory expansion mode.

$\overline{\text{RESET}}$ input sets port 4 to input mode.

Figures 6-10 and 6-11 show a block diagram of port 4 and block diagram of falling edge detection circuit, respectively.

Figure 6-10. P40 to P47 Block Diagram

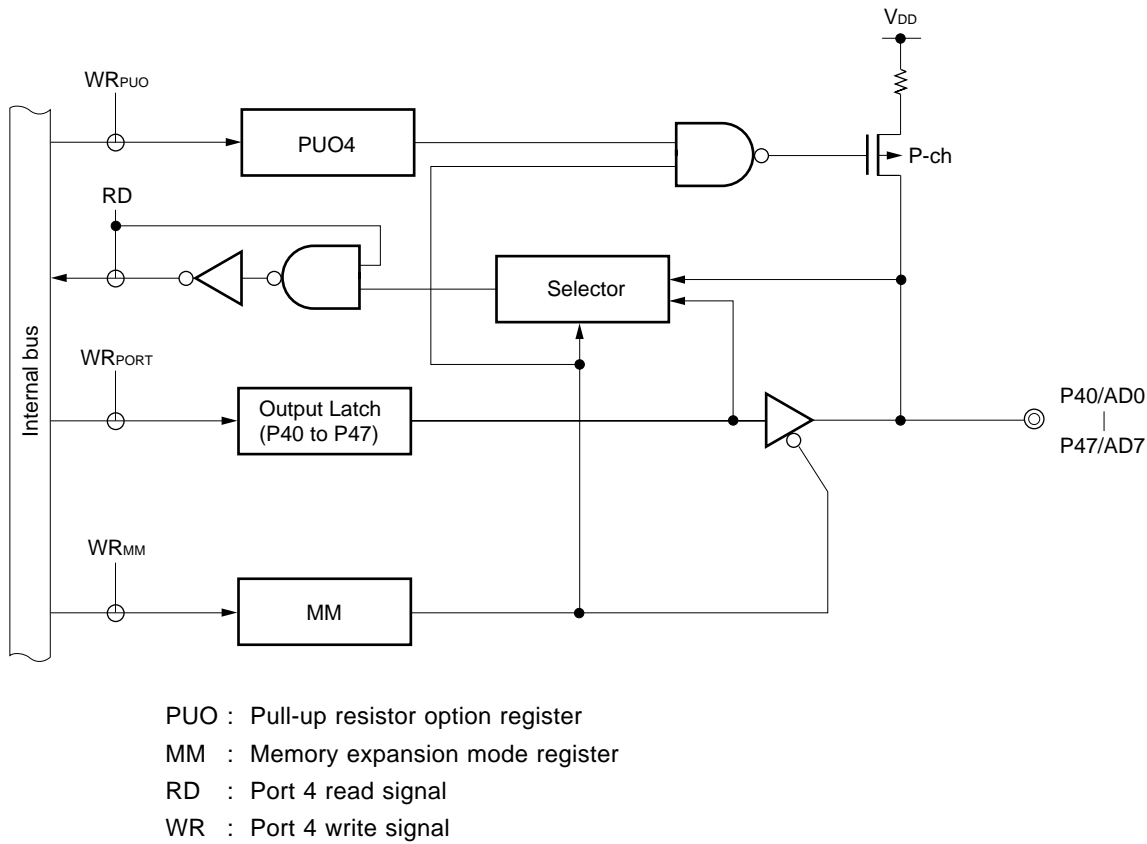
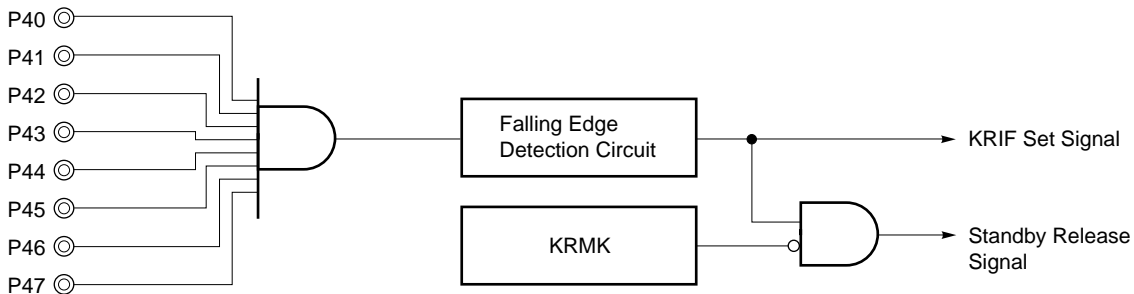


Figure 6-11. Block Diagram of Falling Edge Detection Circuit



6.2.7 Port 5

Port 5 is an 8-bit input/output port with output latch. P50 to P57 pins can specify the input mode/output mode in 1-bit units with the port mode register 5 (PM5). When P50 to P57 pins are used as input ports, an on-chip pull-up resistor can be used to them in 8-bit units with a pull-up resistor option register L (PUOL).

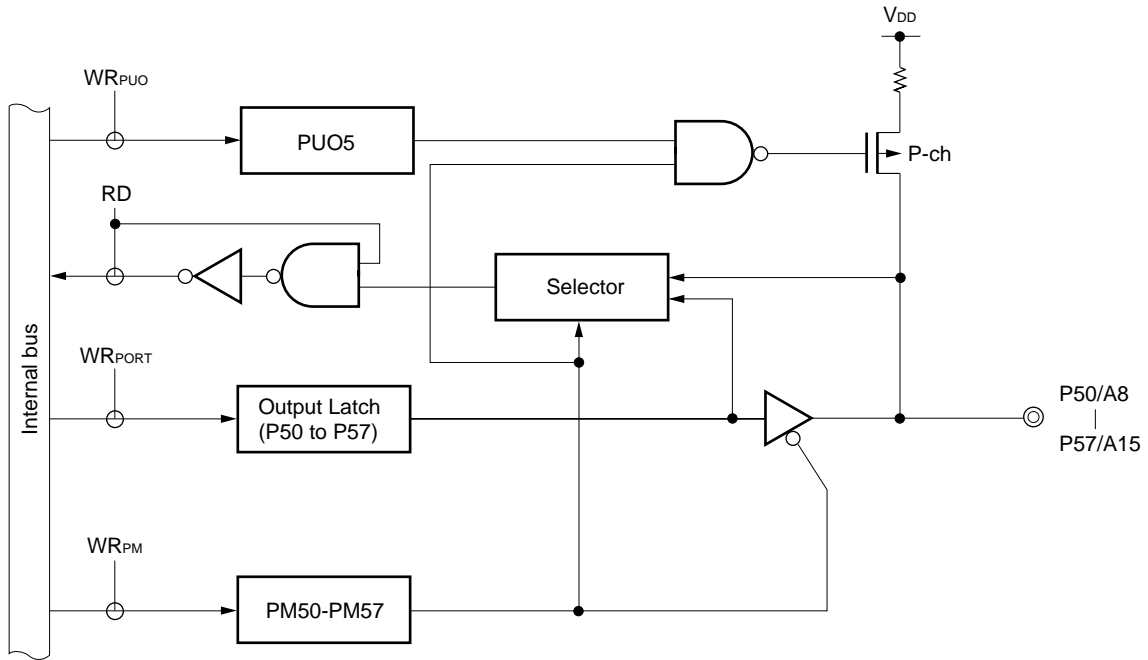
Port 5 can drive LEDs directly.

Alternate function includes address bus function in external memory expansion mode.

$\overline{\text{RESET}}$ input sets port 5 to input mode.

Figure 6-12 shows a block diagram of port 5.

Figure 6-12. P50 to P57 Block Diagram



- PUO : Pull-up resistor option register
- PM : Port mode register
- RD : Port 5 read signal
- WR : Port 5 write signal

6.2.8 Port 6

Port 6 is an 8-bit input/output port with output latch. P60 to P67 pins can specify the input mode/output mode in 1-bit units with the port mode register 6 (PM6).

This port has functions related to pull-up resistors as shown below. These functions depending on whether the higher 4 bits or lower 4 bits of a port are used, and whether the mask ROM model or PROM model is used.

Table 6-4. Pull-up Resistor of Port 6

	Higher 4 Bits (P64 through P67 pins)	Lower 4 bits (P60 through P63 pins)
Mask ROM version	On-chip pull-up resistor can be connected in 4-bit units by PUO6	Pull-up resistor can be connected in 1-bit units by mask option
PROM version		Pull-up resistor is not connected

PUO6: Bit 6 of pull-up resistor option register L (PUOL)

Pins P60 to P63 can drive LEDs directly.

Pins P64 to P67 also serve as control signal output in external memory expansion mode.

$\overline{\text{RESET}}$ input sets port 6 to input mode.

Figures 6-13 and 6-14 show block diagrams of port 6.

- Cautions**
1. When external wait is not used in external memory expansion mode, P66 can be used as an input/output port.
 2. The value of the low-level input leakage current flowing to the P60 through P63 pins differ depending on the following conditions:

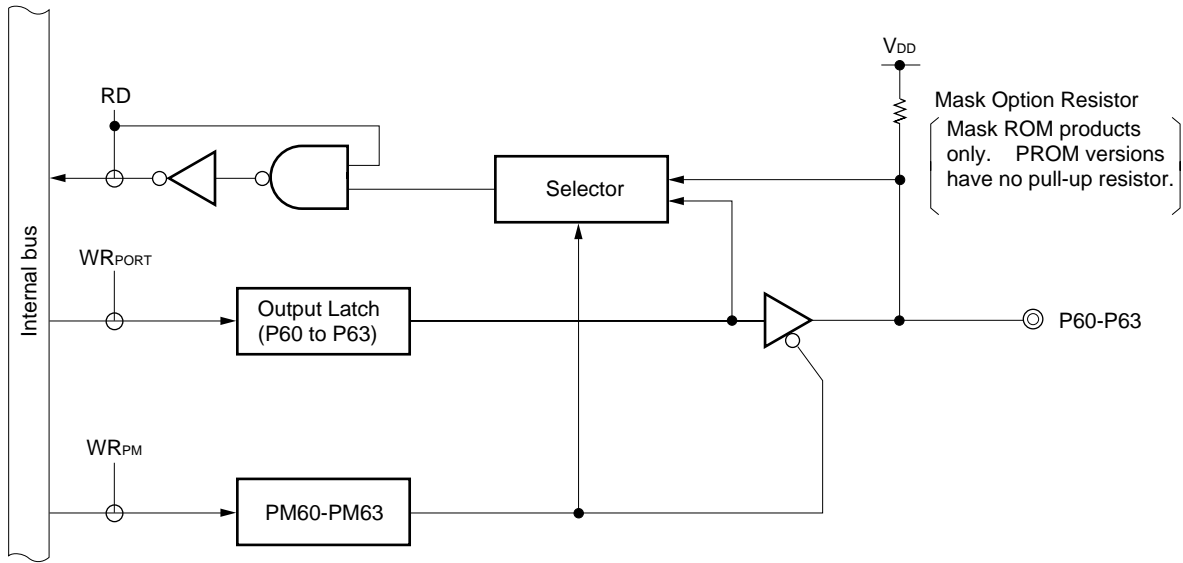
[Mask ROM version]

- When pull-up resistor is connected: always $-3 \mu\text{A}$ (MAX.)
- When pull-up resistor is not connected
 - For duration of 1.5 clock (no wait) when instruction to read port 6 (P6) and port mode register 6 (PM6) is executed: $-200 \mu\text{A}$ (MAX.)
 - Other than above: $-3 \mu\text{A}$ (MAX.)

[PROM version]

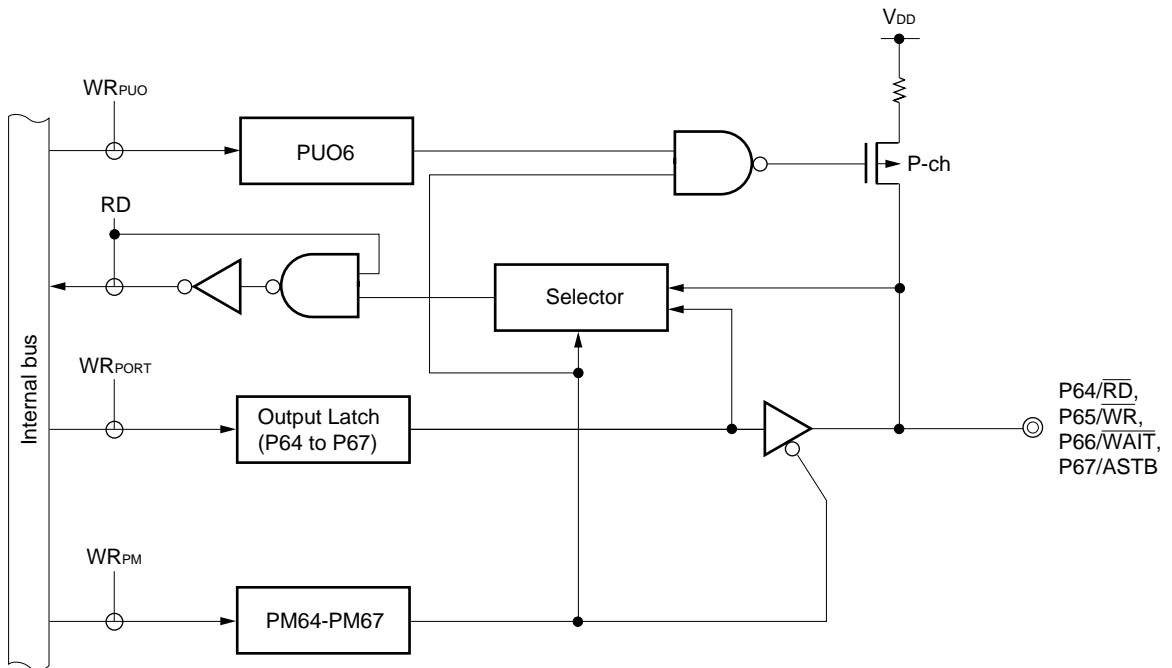
- For duration of 1.5 clock (no wait) when instruction to read port 6 (P6) and port mode register 6 (PM6) is executed: $-200 \mu\text{A}$ (MAX.)
- Other than above: $-3 \mu\text{A}$ (MAX.)

Figure 6-13. P60 to P63 Block Diagram



PM : Port mode register
 RD : Port 6 read signal
 WR : Port 6 write signal

Figure 6-14. P64 to P67 Block Diagram



PUO : Pull-up resistor option register
 PM : Port mode register
 RD : Port 6 read signal
 WR : Port 6 write signal

6.2.9 Port 7

This is a 3-bit input/output port with output latches. Input mode/output mode can be specified bit-wise by means of port mode register 7 (PM7). When pins P70 to P72 are used as input port pins, an on-chip pull-up resistor can be used as a 3-bit unit by means of pull-up resistor option register L (PUOL).

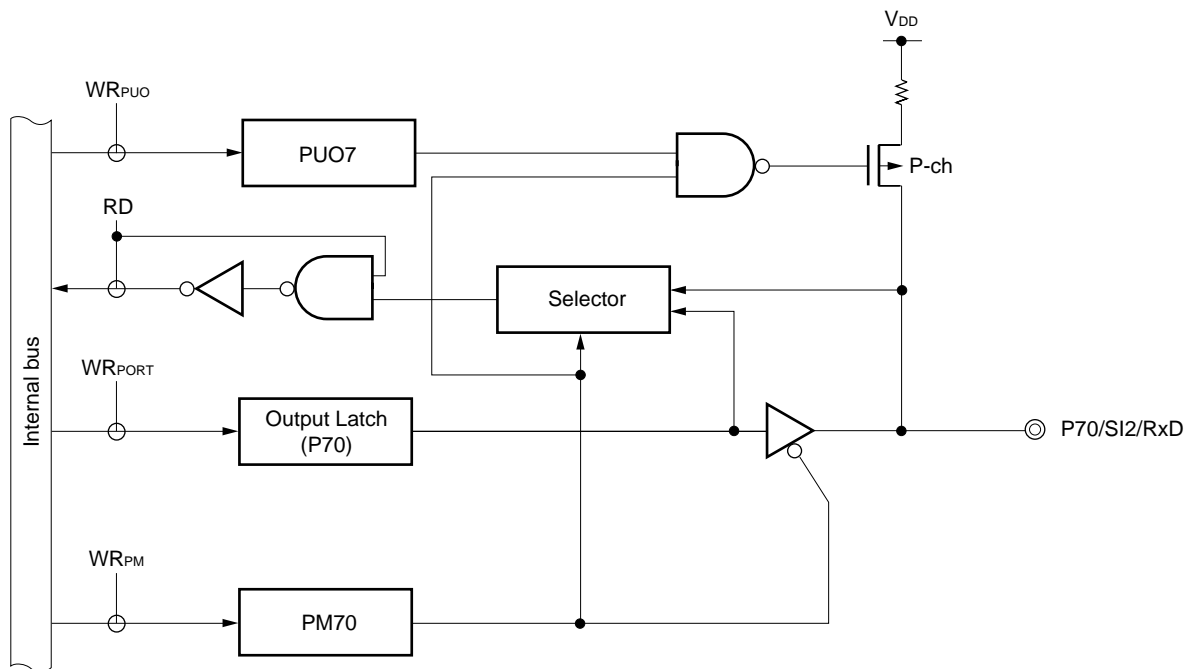
Alternate functions include serial interface channel 2 data input/output and clock input/output.

$\overline{\text{RESET}}$ input sets the input mode.

Figures 6-15 and 6-16 show block diagrams of port 7.

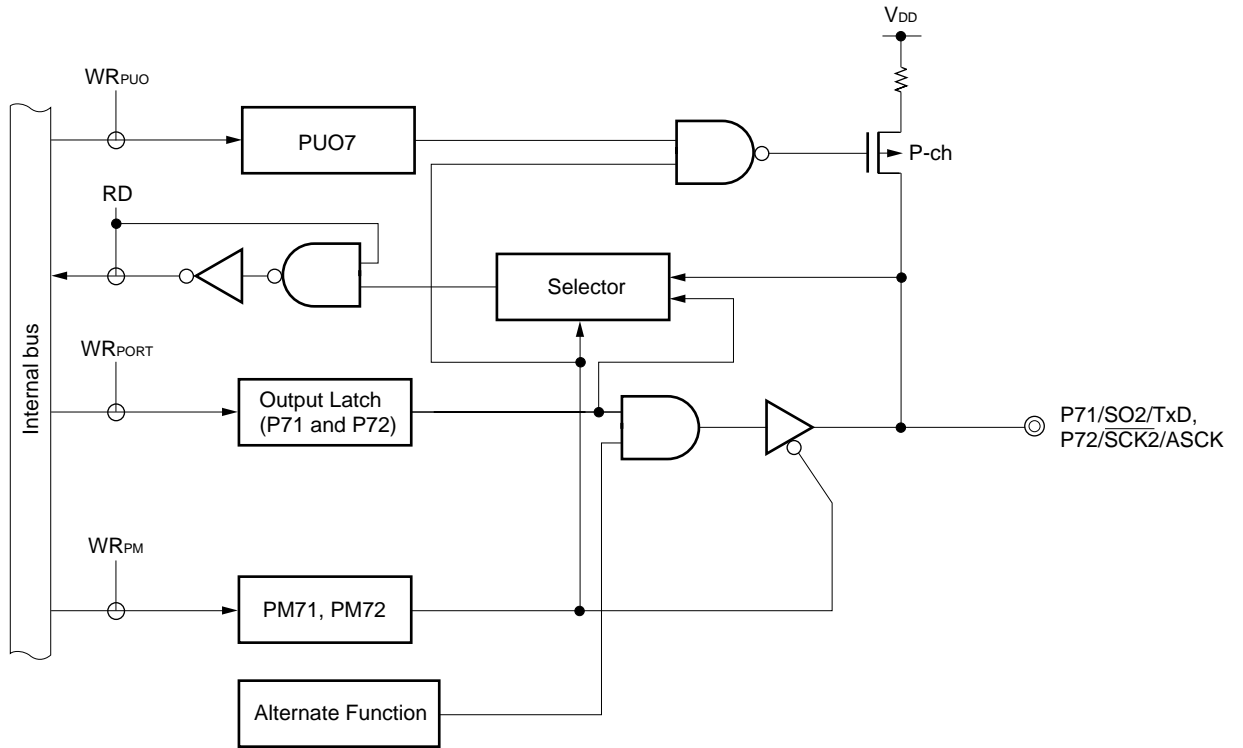
Caution When used as a serial interface, set the input/output and output latch according to its functions. For the setting method, refer to Table 19-2 Serial Interface Channel 2 Operating Mode Setting.

Figure 6-15. P70 Block Diagram



- PUO : Pull-up resistor option register
- PM : Port mode register
- RD : Port 7 read signal
- WR : Port 7 write signal

Figure 6-16. P71 and P72 Block Diagram



- PUO : Pull-up resistor option register
- PM : Port mode register
- RD : Port 7 read signal
- WR : Port 7 write signal

6.2.10 Port 12

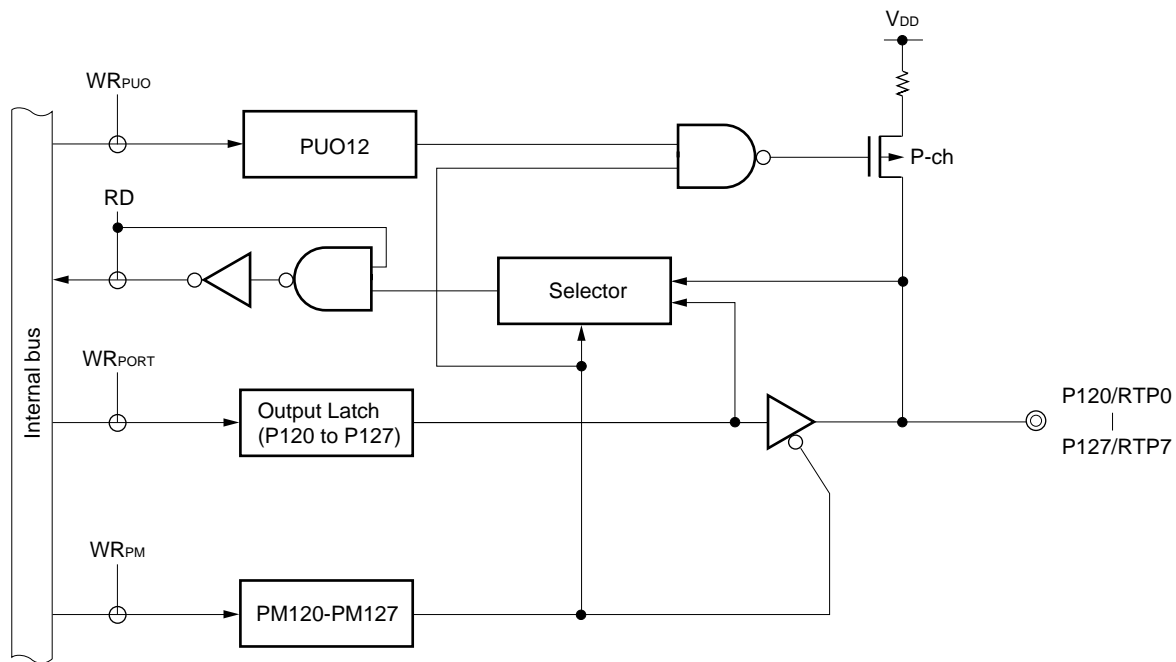
This is an 8-bit input/output port with output latches. Input mode/output mode can be specified bit-wise by means of port mode register 12 (PM12). When pins P120 to P127 are used as input port pins, an on-chip pull-up resistor can be used as an 8-bit unit by means of pull-up resistor option register H (PUOH).

Alternate function includes real-time output.

$\overline{\text{RESET}}$ input sets the input mode.

Figure 6-17 shows a block diagram of port 12.

Figure 6-17. P120 to P127 Block Diagram



PUO : Pull-up resistor option register

PM : Port mode register

RD : Port 12 read signal

WR : Port 12 write signal

6.2.11 Port 13

This is a 2-bit input/output port with output latches. Input mode/output mode can be specified bit-wise by means of port mode register 13 (PM13). When pins P130 and P131 are used as input port pins, an on-chip pull-up resistor can be used as a 2-bit unit by means of pull-up resistor option register H (PUOH).

Alternate function includes D/A converter analog output.

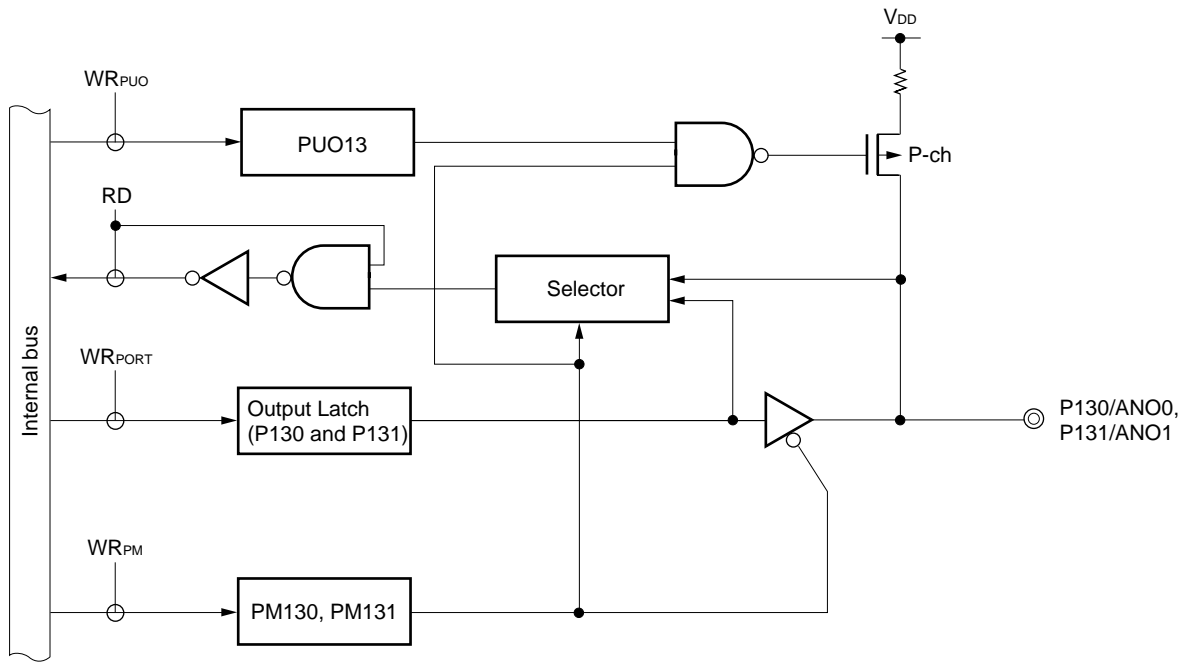
$\overline{\text{RESET}}$ input sets the input mode.

Figure 6-18 shows a block diagram of port 13.

Caution When only either one of the D/A converter channels is used with $\text{AV}_{\text{REF1}} < \text{V}_{\text{DD}}$, the other pins that are not used as analog outputs must be set as follows:

- Set PM13. bit of the port mode register 13 (PM13) to 1 (input mode) and connect the pin to V_{SS} .
- Set PM13x bit of the port mode register 13 (PM13) to 0 (output mode) and the output latch to 0, to output low level from the pin.

Figure 6-18. P130 and P131 Block Diagram



- PUO : Pull-up resistor option register
- PM : Port mode register
- RD : Port 13 read signal
- WR : Port 13 write signal

6.3 Port Function Control Registers

The following four types of registers control the ports.

- Port mode registers (PM0 to PM3, PM5 to PM7, PM12, PM13)
- Pull-up resistor option register (PUOH, PUOL)
- Memory expansion mode register (MM)
- Key return mode register (KRM)

(1) Port mode registers (PM0 to PM3, PM5 to PM7, PM12, PM13)

These registers are used to set port input/output in 1-bit units.

PM0 to PM3, PM5 to PM7, PM12, and PM13 are independently set with a 1-bit or 8-bit memory manipulation instruction

$\overline{\text{RESET}}$ input sets registers to FFH.

When port pins are used as the dual-function pins, set the port mode register and output latch according to Table 6-5.

Cautions 1. Pins P00 and P07 are input-only pins.

2. As port 0 has a dual function as external interrupt request input, when the port function output mode is specified and the output level is changed, the interrupt request flag is set. When the output mode is used, therefore, the interrupt mask flag should be set to 1 beforehand.
3. The memory expansion mode register (MM) specifies P40 to P47 as input/output pins.

Table 6-5. Port Mode Register and Output Latch Settings when Using Dual-Functions

Pin Name	Dual-functions		PM _{xx}	P _{xx}
	Name	Input/Output		
P00	INTP0	Input	1 (Fixed)	None
	TI00	Input	1 (Fixed)	None
P01	INTP1	Input	1	×
	TI01	Input	1	×
P02 to P06	INTP2 to INTP6	Input	1	×
P07 ^{Note1}	XT1	Input	1 (Fixed)	None
P10 to P17 ^{Note1}	ANI0 to ANI7	Input	1	×
P30 to P32	TO0 to TO2	Output	0	0
P33, P34	TI1, TI2	Input	1	×
P35	PCL	Output	0	0
P36	BUZ	Output	0	0
P40 to P47	AD0 to AD7	Input/Output	× ^{Note2}	
P50 to P57	A8 to A15	Output	× ^{Note2}	
P64	\overline{RD}	Output	× ^{Note2}	
P65	\overline{WR}	Output	× ^{Note2}	
P66	\overline{WAIT}	Input	× ^{Note2}	
P67	ASTB	Output	× ^{Note2}	
P120 to P127	RTP0 to RTP7	Output	0	desired value
P130, P131 ^(Note1)	ANO0, ANO1	Output	1	×

- Notes**
1. If these ports are read out when these pins are used in the alternative function mode, undefined values are read.
 2. When the P40 to P47 pins P50 to P57 pins, and P64 to P67 pins are used for dual-functions, set the function by the memory extension mode register (MM).

- Cautions**
1. When not using external wait in the external memory extension mode, the P66 pin can be used as an I/O port.
 2. When port 2 and port 7 are used for serial interface, the I/O latch or output latch must be set according to its function. For the setting methods, see Figure 16-4 “Serial Operation Mode Register 0 Format”, Figure 17-4 “Serial Operation Mode Register 0 Format”, Figure 18-3 “Serial Operation Mode Register 1 Format”, and Table 19-2 “Serial Interface Channel 2 Operating Mode Settings”.

Remarks

- × : don't care
- PM_{xx} : port mode register
- P_{xx} : port output latch

Figure 6-19. Port Mode Register Format

Symbol	7	6	5	4	3	2	1	0	Address	After Reset	R/W
PM0	1	PM06	PM05	PM04	PM03	PM02	PM01	1	FF20H	FFH	R/W
PM1	PM17	PM16	PM15	PM14	PM13	PM12	PM11	PM10	FF21H	FFH	R/W
PM2	PM27	PM26	PM25	PM24	PM23	PM22	PM21	PM20	FF22H	FFH	R/W
PM3	PM37	PM36	PM35	PM34	PM33	PM32	PM31	PM30	FF23H	FFH	R/W
PM5	PM57	PM56	PM55	PM54	PM53	PM52	PM51	PM50	FF25H	FFH	R/W
PM6	PM67	PM66	PM65	PM64	PM63	PM62	PM61	PM60	FF26H	FFH	R/W
PM7	1	1	1	1	1	PM72	PM71	PM70	FF27H	FFH	R/W
PM12	PM127	PM126	PM125	PM124	PM123	PM122	PM121	PM120	FF2CH	FFH	R/W
PM13	1	1	1	1	1	1	PM131	PM130	FF2DH	FFH	R/W

PMmn	Pmn Pin Input/Output Mode Selection (m=0-3, 5-7, 12, 13 : n=0-7)
0	Output mode (output buffer ON)
1	Input mode (output buffer OFF)

(2) Pull-up resistor option register (PUOH, PUOL)

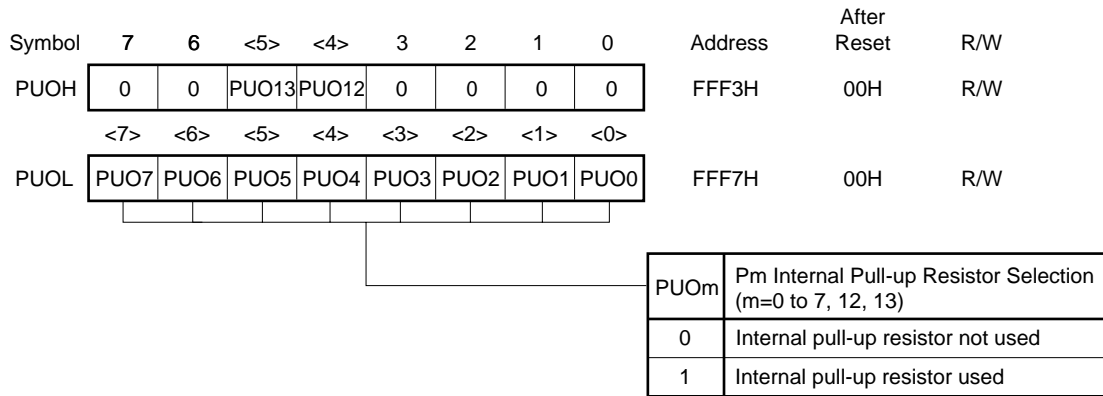
This register is used to set whether to use an internal pull-up resistor at each port or not. A pull-up resistor is internally used at bits which are set to the input mode at a port where on-chip pull-up resistor use has been specified with PUOH, PUOL. No on-chip pull-up resistors can be used to the bits set to the output mode or to the bits used as an analog input pin, irrespective of PUOH or PUOL setting.

PUOH and PUOL are set with a 1-bit or 8-bit memory manipulation instruction.

$\overline{\text{RESET}}$ input sets this register to 00H.

- Cautions**
1. P00 and P07 pins do not incorporate a pull-up resistor.
 2. When ports 1, 4, 5, and P64 to P67 pins are used as dual-function pins, an on-chip pull-up resistor cannot be used even if 1 is set in PUOm bit of PUOH, PUOL (m = 1, 4 to 6).
 3. Pins P60 to P63 can be connected with pull-up resistor by mask option only for mask ROM version.

Figure 6-20. Pull-Up Resistor Option Register Format



Caution Bits 0 to 3, 6, and 7 of PUOH should be set to 0.

(3) Memory expansion mode register (MM)

This register is used to set input/output of port 4.

MM is set with a 1-bit or 8-bit memory manipulation instruction.

$\overline{\text{RESET}}$ input sets this register to 10H.

Figure 6-21. Memory Expansion Mode Register Format

Symbol	7	6	5	4	3	2	1	0	Address	After Reset	R/W
MM	0	0	PW1	PW0	0	MM2	MM1	MM0	FFF8H	10H	R/W

MM2	MM1	MM0	Single-chip/Memory Expansion Mode Selection		P40-P47, P50-P57, P64-P67 Pin State					
					P40-P47	P50-P53	P54, P55	P56, P57	P64-P67	
0	0	0	Single-chip mode		Port mode	Input	Port mode			
0	0	1								
0	1	1	Memory expansion mode	256-byte mode	AD0-AD7	Port mode				P64= $\overline{\text{RD}}$ P65= $\overline{\text{WR}}$ P66= $\overline{\text{WAIT}}$ P67=ASTB
1	0	0		4-Kbyte mode		A8-A11	Port mode			
1	0	1		16-Kbyte mode			A12, A13	Port mode		
1	1	1		Full ^{Note} address mode		A14, A15				
Other than above			Setting prohibited							

PW1	PW0	Wait Control
0	0	No wait
0	1	Wait (one wait state insertion)
1	0	Setting prohibited
1	1	Wait control by external wait pin

Note The full address mode allows external expansion for all areas of the 64-Kbyte address space, except the internal ROM, RAM, SFR, and use-prohibited areas.

- Remarks**
1. P60 to P63 pins enter the port mode in both the single-chip and memory expansion mode.
 2. Besides setting port 4 input/output, MM also sets the wait count and external expansion area.

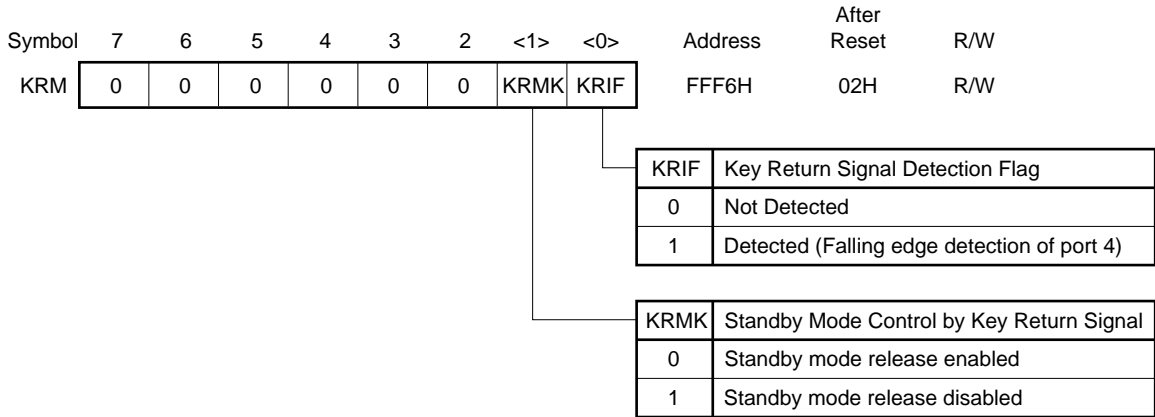
(4) Key return mode register (KRM)

This register sets enabling/disabling of standby function release by a key return signal (falling edge detection of port 4).

KRM is set with a 1-bit or 8-bit memory manipulation instruction.

$\overline{\text{RESET}}$ input sets KRM to 02H.

Figure 6-22. Key Return Mode Register Format



Caution When falling edge detection of port4 is used, KRIF should be cleared to 0 (not cleared to 0 automatically).

6.4 Port Function Operations

Port operations differ depending on whether the input or output mode is set, as shown below.

6.4.1 Writing to input/output port

(1) Output mode

A value is written to the output latch by a transfer instruction, and the output latch contents are output from the pin.

Once data is written to the output latch, it is retained until data is written to the output latch again.

(2) Input mode

A value is written to the output latch by a transfer instruction, but since the output buffer is OFF, the pin status does not change.

Once data is written to the output latch, it is retained until data is written to the output latch again.

Caution In the case of 1-bit memory manipulation instruction, although a single bit is manipulated the port is accessed as an 8-bit unit. Therefore, on a port with a mixture of input and output pins, the output latch contents for pins specified as input are undefined except for the manipulated bit.

6.4.2 Reading from input/output port

(1) Output mode

The output latch contents are read by a transfer instruction. The output latch contents do not change.

(2) Input mode

The pin status is read by a transfer instruction. The output latch contents do not change.

6.4.3 Operations on input/output port

(1) Output mode

An operation is performed on the output latch contents, and the result is written to the output latch. The output latch contents are output from the pins.

Once data is written to the output latch, it is retained until data is written to the output latch again.

(2) Input mode

The output latch contents are undefined, but since the output buffer is OFF, the pin status does not change.

Caution In the case of 1-bit memory manipulation instruction, although a single bit is manipulated the port is accessed as an 8-bit unit. Therefore, on a port with a mixture of input and output pins, the output latch contents for pins specified as input are undefined, even for bits other than the manipulated bit.

6.5 Selection of Mask Option

The following mask option is provided in mask ROM version. The PROM versions have no mask options.

Table 6-6. Comparison between Mask ROM Version and PROM Version

Pin Name	Mask ROM Version	PROM Version
Mask option for pins P60 to P63	Bit-wise-selectable on-chip pull-up resistors	No on-chip pull-up resistor

[MEMO]

CHAPTER 7 CLOCK GENERATOR

7.1 Clock Generator Functions

The clock generator generates the clock to be supplied to the CPU and peripheral hardware. The following two types of system clock oscillators are available.

(1) Main system clock oscillator

This circuit oscillates at frequencies of 1 to 5.0 MHz. Oscillation can be stopped by executing the STOP instruction or setting the processor clock control register (PCC).

(2) Subsystem clock oscillator

The circuit oscillates at a frequency of 32.768 kHz. Oscillation cannot be stopped. If the subsystem clock oscillator is not used, not using the internal feedback resistance can be set by the processor clock control register (PCC). This enables to decrease power consumption in the STOP mode.

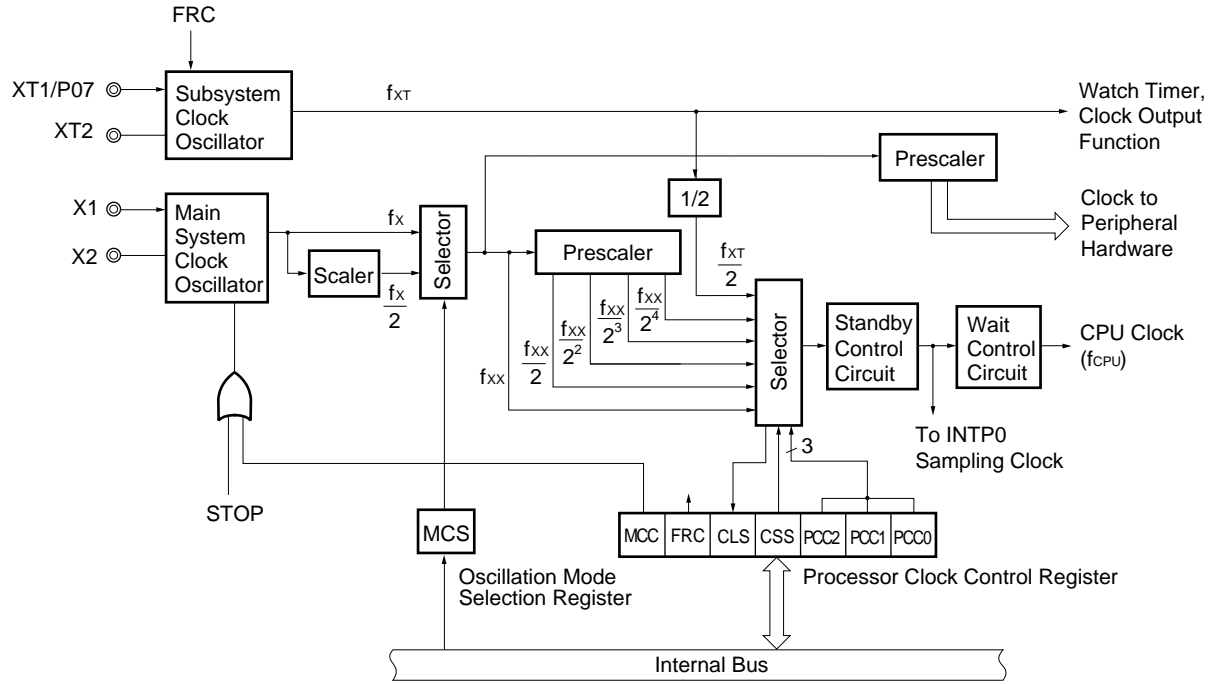
7.2 Clock Generator Configuration

The clock generator consists of the following hardware.

Table 7-1. Clock Generator Configuration

Item	Configuration
Control register	Processor clock control register (PCC) Oscillation mode selection register (OSMS)
Oscillator	Main system clock oscillator Subsystem clock oscillator

Figure 7-1. Block Diagram of Clock Generator



7.3 Clock Generator Control Register

The clock generator is controlled by the following two registers:

- Processor clock control register (PCC)
- Oscillation mode selection register (OSMS)

(1) Processor clock control register (PCC)

The PCC sets whether to use CPU clock selection, the ratio of division, main system clock oscillator operation/stop and subsystem clock oscillator internal feedback resistor.

The PCC is set with a 1-bit or 8-bit memory manipulation instruction.

$\overline{\text{RESET}}$ input sets the PCC to 04H.

Figure 7-2. Subsystem Clock Feedback Resistor

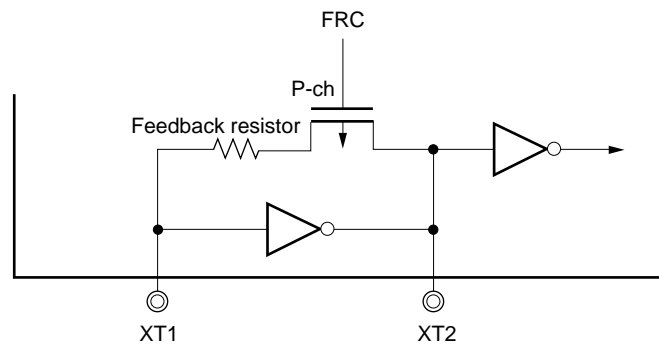


Figure 7-3. Processor Clock Control Register Format

Symbol	<7>	<6>	<5>	<4>	3	2	1	0	Address	After Reset	R/W
PCC	MCC	FRC	CLS	CSS	0	PCC2	PCC1	PCC0	FFFBH	04H	R/W ^{Note 1}

R/W	CSS	PCC2	PCC1	PCC0	CPU Clock (f_{CPU}) Selection		
					MCS = 1		MCS = 0
0	0	0	0	f_{xx}	f_x	$f_x/2$	
	0	0	1	$f_{xx}/2$	$f_x/2$	$f_x/2^2$	
	0	1	0	$f_{xx}/2^2$	$f_x/2^2$	$f_x/2^3$	
	0	1	1	$f_{xx}/2^3$	$f_x/2^3$	$f_x/2^4$	
	1	0	0	$f_{xx}/2^4$	$f_x/2^4$	$f_x/2^5$	
1	0	0	0	$f_{XT}/2$			
	0	0	1				
	0	1	0				
	0	1	1				
	1	0	0				
Other than above				Setting prohibited			

R	CLS	CPU Clock Status
	0	Main system clock
	1	Subsystem clock

R/W	FRC	Subsystem Clock Feedback Resistor Selection
	0	Internal feedback resistor used
	1	Internal feedback resistor not used

R/W	MCC	Main System Clock Oscillation Control ^{Note 2}
	0	Oscillation possible
	1	Oscillation stopped

Notes 1. Bit 5 is Read Only.

2. When the CPU is operating on the subsystem clock, MCC should be used to stop the main system clock oscillation. A STOP instruction should not be used.

Caution Bit 3 must be set to 0.

- Remarks**
1. f_{xx} : Main system clock frequency (f_x or $f_x/2$)
 2. f_x : Main system clock oscillator frequency
 3. f_{XT} : Subsystem clock oscillator frequency
 4. MCS : Bit 0 of oscillation mode selection register (OSMS)

The fastest instruction of the μ PD78054 and 78054Y Subseries is executed with two clocks of the CPU clock. Therefore, relationships between the CPU clock (f_{CPU}) and the minimum instruction execution time are as shown in Table 7-2.

Table 7-2. Relationship between CPU Clock and Minimum Instruction Execution Time

CPU Clock (f_{CPU})	Minimum Instruction Execution Time: $2/f_{CPU}$
f_X	0.4 μs
$f_X/2$	0.8 μs
$f_X/2^2$	1.6 μs
$f_X/2^3$	3.2 μs
$f_X/2^4$	6.4 μs
$f_X/2^5$	12.8 μs
$f_{XT}/2$	122 μs

- Remarks**
1. $f_X = 5.0$ MHz, $f_{XT} = 32.768$ kHz
 2. f_X : Main system clock oscillation frequency
 3. f_{XT} : Subsystem clock oscillation frequency

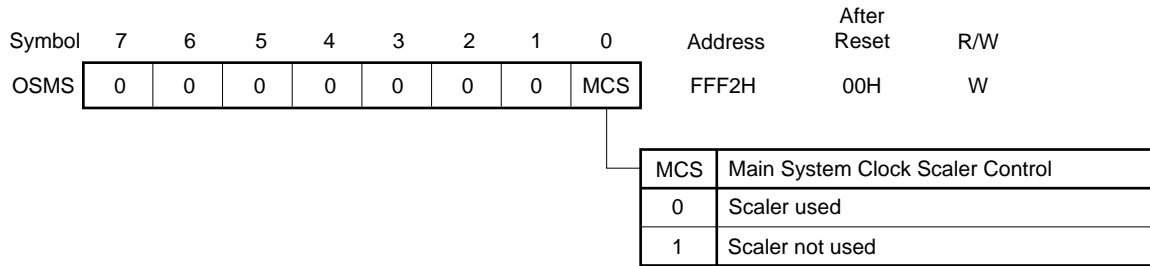
(2) Oscillation mode selection register (OSMS)

This register specifies whether the clock output from the main system clock oscillator without passing through the scaler is used as the main system clock, or the clock output via the scaler is used as the main system clock.

OSMS is set with 8-bit memory manipulation instruction.

$\overline{\text{RESET}}$ input sets OSMS to 00H.

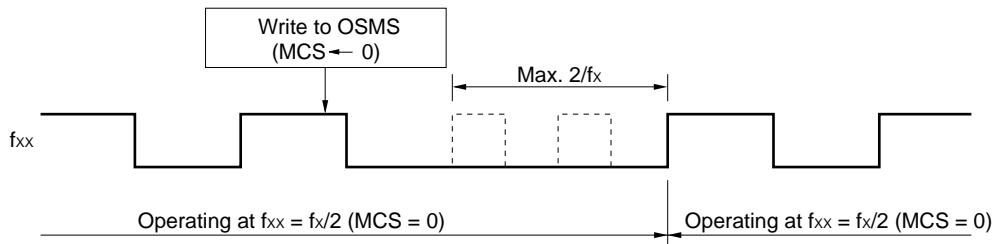
Figure 7-4. Oscillation Mode Selection Register Format



Cautions 1. The main system clock cycle is longer by up to $2/f_x$ only when writing data to OSMS (including when writing the same data that was written previously) as shown in Figure 7-5. This causes a temporary error in the count clock cycle of timers in the peripheral hardware that operates with the main system clock.

In addition, when the oscillation mode is changed, the clocks provided for the peripheral hardware as well as those for the CPU are switched. Therefore, it is recommended that only one-time writing to OSMS be performed between the reset release and the peripheral hardware operation.

Figure 7-5. Main System Clock when Writing to OSMS



2. Setting 1 to MCS should be performed after $V_{DD} \geq 2.7$ V.

Remarks f_{xx} : Main system clock frequency (f_x or $f_x/2$)

f_x : Main system clock oscillation frequency

7.4 System Clock Oscillator

7.4.1 Main system clock oscillator

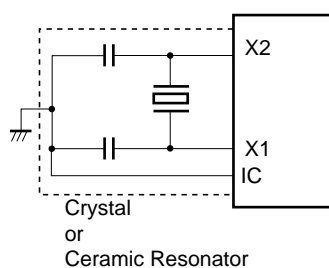
The main system clock oscillator oscillates with a crystal resonator or a ceramic resonator (standard: 5.0 MHz) connected to the X1 and X2 pins.

External clocks can be input to the main system clock oscillator. In this case, input a clock signal to the X1 pin and an antiphase clock signal to the X2 pin.

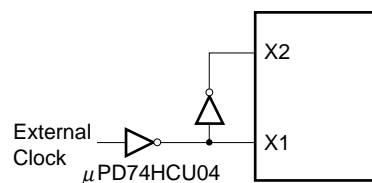
Figure 7-6 shows an external circuit of the main system clock oscillator.

Figure 7-6. External Circuit of Main System Clock Oscillator

(a) Crystal and ceramic oscillation



(b) External clock



Caution Do not execute the STOP instruction or do not set MCC (bit 7 of processor clock control register (PCC)) to 1 if an external clock is used. This is because if STOP instruction is executed or MCC is set to 1, the operation of the main system clock is stopped and the X2 pin is pulled up to V_{DD} .

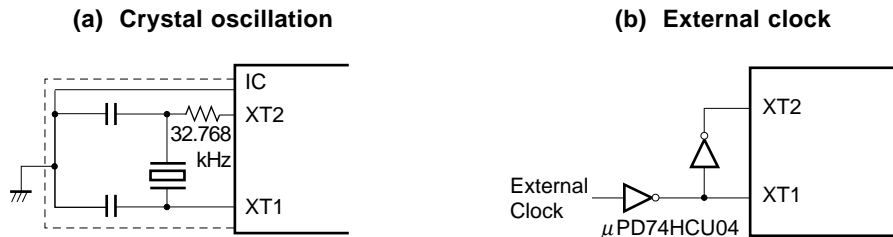
7.4.2 Subsystem clock oscillator

The subsystem clock oscillator oscillates with a crystal resonator (standard: 32.768 kHz) connected to the XT1 and XT2 pins.

External clocks can be input to the main system clock oscillator. In this case, input a clock signal to the XT1 pin and an antiphase clock signal to the XT2 pin.

Figure 7-7 shows an external circuit of the subsystem clock oscillator.

Figure 7-7. External Circuit of Subsystem Clock Oscillator



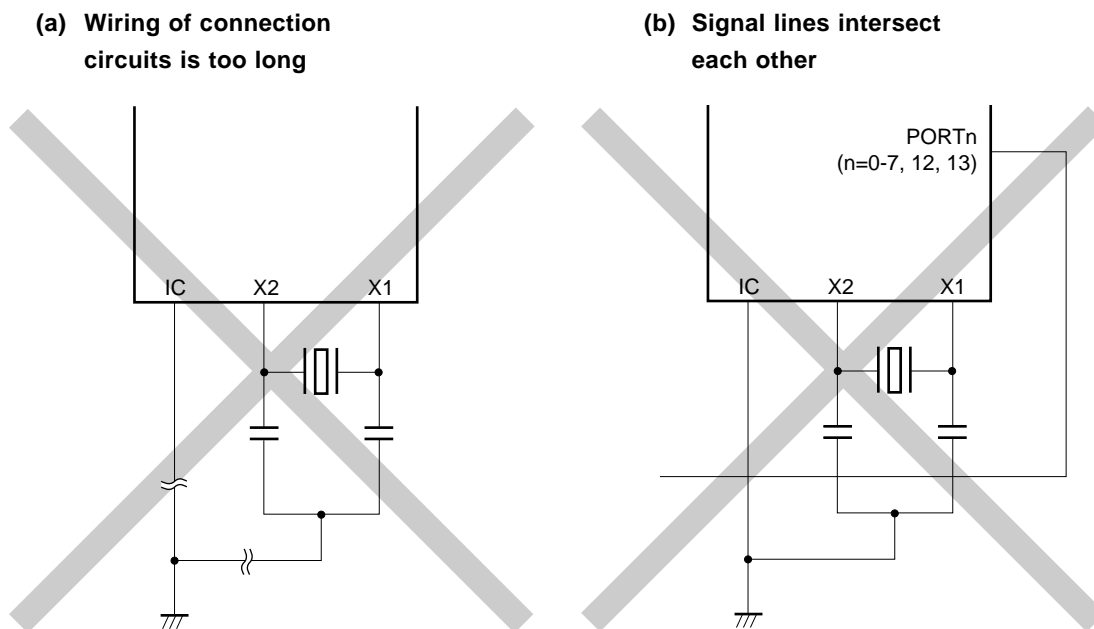
Cautions 1. When using a main system clock oscillator and a subsystem clock oscillator, carry out wiring in the broken line area in Figures 7-6 and 7-7 to prevent any effects from wiring capacities.

- Minimize the wiring length.
- Do not allow wiring to intersect with other signal conductors. Do not allow wiring to come near changing high current.
- Set the potential of the grounding position of the oscillator capacitor to that of V_{SS} . Do not ground to any ground pattern where high current is present.
- Do not fetch signals from the oscillator.

Take special note of the fact that the subsystem clock oscillator is a circuit with low-level amplification so that current consumption is maintained at low levels.

Figure 7-8 shows examples of incorrect oscillator connection.

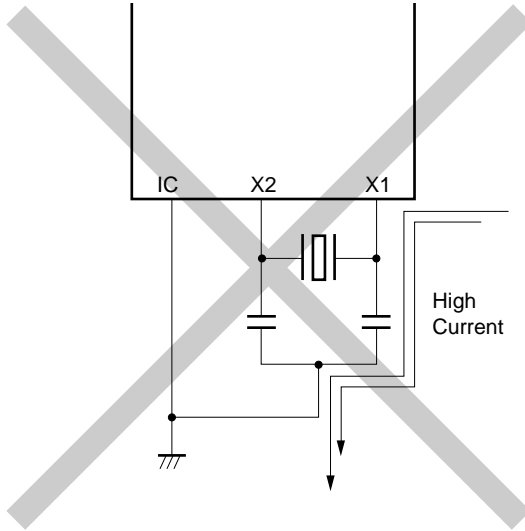
Figure 7-8. Examples of Incorrect Oscillator Connection (1/2)



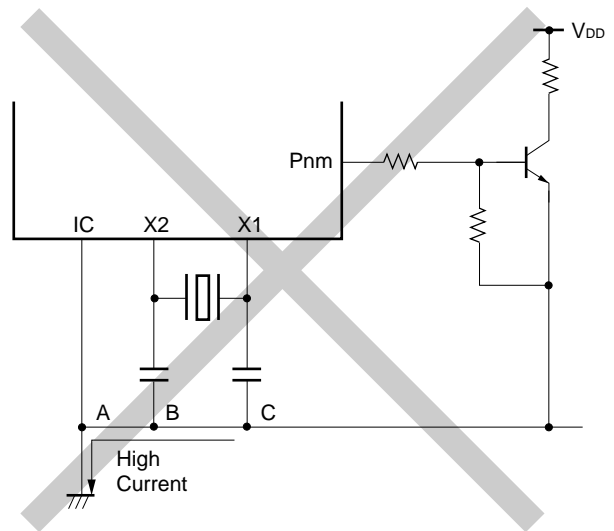
Remark When using a subsystem clock, replace X1 and X2 with XT1 and XT2, respectively. Further, insert resistors in series on the side of XT2.

Figure 7-8. Examples of Incorrect Oscillator Connection (2/2)

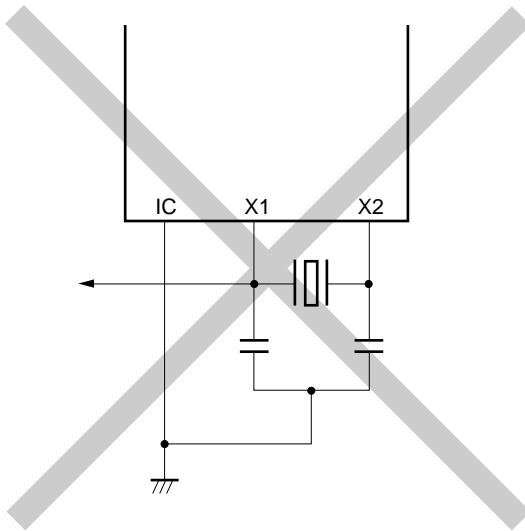
(c) Changing high current is too near a signal conductor



(d) Current flows through the grounding line of the oscillator (potential at points A, B, and C fluctuate)



(e) Signals are fetched



Remark When using a subsystem clock, replace X1 and X2 with XT1 and XT2, respectively. Also, insert resistors in series on the XT2 side.

Cautions 2. In Figure 7-8 (f), XT2 and X1 are wired in parallel. Thus, the cross-talk noise of X1 may increase with XT2, resulting in malfunctioning. To prevent that from occurring, it is recommended to wire XT2 and X1 so that they are not in parallel, and to correct the IC pin between XT2 and X1 directly to V_{ss}.

7.4.3 Scaler

The scaler divides the main system clock oscillator output (f_{xx}) and generates various clocks.

7.4.4 When no subsystem clocks are used

If it is not necessary to use subsystem clocks for low power consumption operations and clock operations, connect the XT1 and XT2 pins as follows.

XT1: Connect to V_{DD} .

XT2: Leave open.

In this state, however, some current may leak via the internal feedback resistor of the subsystem clock oscillator when the main system clock stops. To suppress the leakage current, disconnect the above internal feedback resistor by using the bit 6 (FRC) of the processor clock control register (PCC). In this case also, connect the XT1 and XT2 pins as described above.

7.5 Clock Generator Operations

The clock generator generates the following various types of clocks and controls the CPU operating mode including the standby mode.

- Main system clock f_{XX}
- Subsystem clock f_{XT}
- CPU clock f_{CPU}
- Clock to peripheral hardware

The following clock generator functions and operations are determined with the processor clock control register (PCC) and the oscillation mode selection register (OSMS).

- (a) Upon generation of $\overline{\text{RESET}}$ signal, the lowest speed mode of the main system clock (12.8 μs when operated at 5.0 MHz) is selected (PCC = 04H, OSMS = 00H). Main system clock oscillation stops while low level is applied to $\overline{\text{RESET}}$ pin.
- (b) With the main system clock selected, one of the six CPU clock types (0.4 μs , 0.8 μs , 1.6 μs , 3.2 μs , 6.4 μs , 12.8 μs @ 5.0 MHz) can be selected by setting the PCC and OSMS.
- (c) With the main system clock selected, two standby modes, the STOP and HALT modes, are available. In a system where the subsystem clock is not used, the current consumption in the STOP mode can be further reduced by specifying with bit 6 (FRC) of the PCC not to use the feedback resistor.
- (d) The PCC can be used to select the subsystem clock and to operate the system with low current consumption (122 μs when operated at 32.768 kHz).
- (e) With the subsystem clock selected, main system clock oscillation can be stopped with the PCC. The HALT mode can be used. However, the STOP mode cannot be used. (Subsystem clock oscillation cannot be stopped.)
- (f) The main system clock is divided and supplied to the peripheral hardware. The subsystem clock is supplied to 16-bit timer/event counter, the watch timer, and clock output functions only. Thus, 16-bit timer/event counter (when selecting watch timer output for count clock operating with subsystem clock), the watch function, and the clock output function can also be continued in the standby state. However, since all other peripheral hardware operate with the main system clock, the peripheral hardware also stops if the main system clock is stopped. (Except external input clock operation)

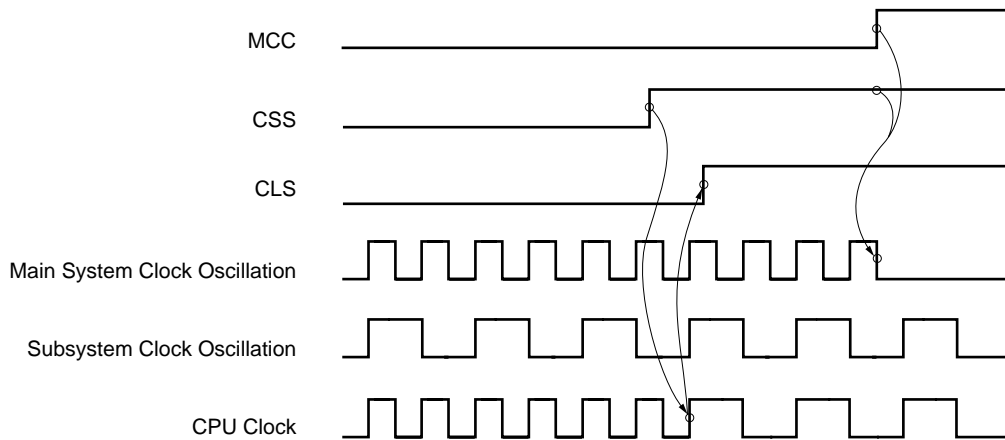
7.5.1 Main system clock operations

When operated with the main system clock (with bit 5 (CLS) of the processor clock control register (PCC) set to 0), the following operations are carried out by PCC setting.

- (a) Because the operation guarantee instruction execution speed depends on the power supply voltage, the minimum instruction execution time can be changed by bits 0 to 2 (PCC0 to PCC2) of the PCC.
- (b) If bit 7 (MCC) of the PCC is set to 1 when operated with the main system clock, the main system clock oscillation does not stop. When bit 4 (CSS) of the PCC is set to 1 and the operation is switched to subsystem clock operation (CLS = 1) after that, the main system clock oscillation stops (see **Figure 7-9**).

Figure 7-9. Main System Clock Stop Function (1/2)

(a) Operation when MCC is set after setting CSS with main system clock operation



(b) Operation when MCC is set in case of main system clock operation

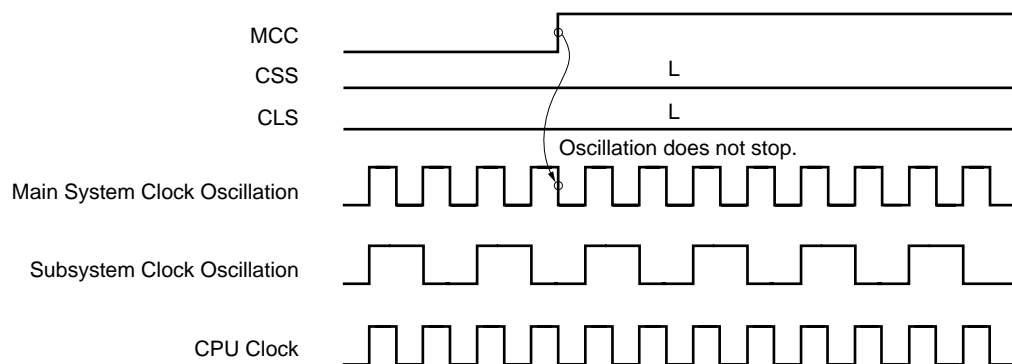
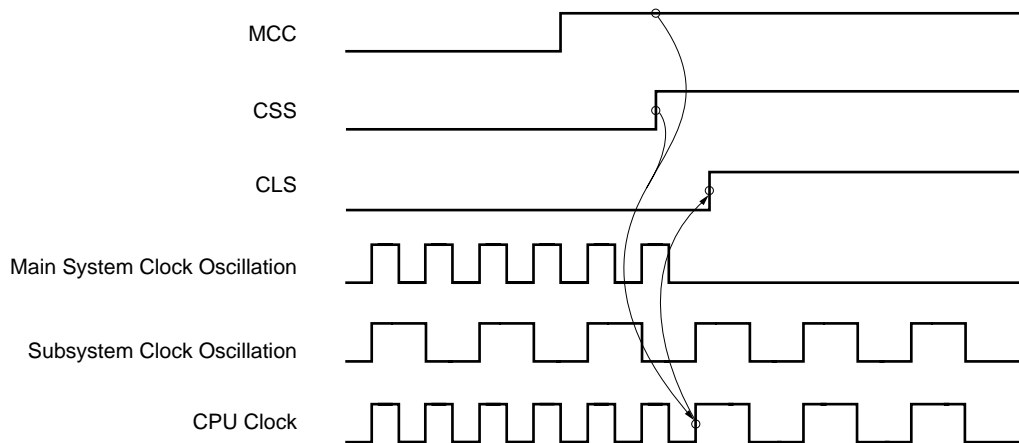


Figure 7-9. Main System Clock Stop Function (2/2)

(c) Operation when CSS is set after setting MCC with main system clock operation



7.5.2 Subsystem clock operations

When operated with the subsystem clock (with bit 5 (CLS) of the processor clock control register (PCC) set to 1), the following operations are carried out.

- The minimum instruction execution time remains constant ($122\ \mu\text{s}$ when operated at 32.768 kHz) irrespective of bits 0 to 2 (PCC0 to PCC2) of the PCC.
- Watchdog timer counting stops.

Caution Do not execute the STOP instruction while the subsystem clock is in operation.

7.6 Changing System Clock and CPU Clock Settings

7.6.1 Time required for switchover between system clock and CPU clock

The system clock and CPU clock can be switched over by means of bits 0 to 2 (PCC0 to PCC2) and bit 4 (CSS) of the processor clock control register (PCC).

The actual switchover operation is not performed directly after writing to the PCC, but operation continues on the pre-switchover clock for several instructions (see **Table 7-3**).

Whether the system is operating on the main system clock or the subsystem clock can be discriminated by bit 5 (CLS) of the PCC register.

Set Values before Switchover				Set Values After Switchover																				MSC = 1				MSC = 0			
																								CSS	PCC2	PCC1	PCC0	CSS	PCC2	PCC1	PCC0
0	0	0	0	0	0	0	0	0	0	0	1	0	0	1	0	0	0	1	1	0	1	0	0	1	×	×	×	1	×	×	×
0	0	0	0	/				16 instructions				16 instructions				16 instructions				16 instructions				f _x /2f _{xT} instruction (77 instructions)				f _x /4f _{xT} instruction (39 instructions)			
0	0	0	1					8 instructions				8 instructions				8 instructions				8 instructions				f _x /4f _{xT} instruction (39 instructions)				f _x /8f _{xT} instruction (20 instructions)			
0	0	1	0					4 instructions				4 instructions				4 instructions				4 instructions				f _x /8f _{xT} instruction (20 instructions)				f _x /16f _{xT} instruction (10 instructions)			
0	1	1	1					2 instructions				2 instructions				2 instructions				2 instructions				f _x /16f _{xT} instruction (10 instructions)				f _x /32f _{xT} instruction (5 instructions)			
1	0	0	0					1 instruction				1 instruction				1 instruction				1 instruction				f _x /32f _{xT} instruction (5 instructions)				f _x /64f _{xT} instruction (3 instructions)			
1	×	×	×	1 instruction				1 instruction				1 instruction				1 instruction				1 instruction				/							

- Remarks**
- One instruction is the minimum instruction execution time with the pre-switchover CPU clock.
 - MCS: Oscillation mode selection register bit 0
 - Figures in parentheses apply to operation with f_x = 5.0 MHz and f_{xT} = 32.768 kHz.

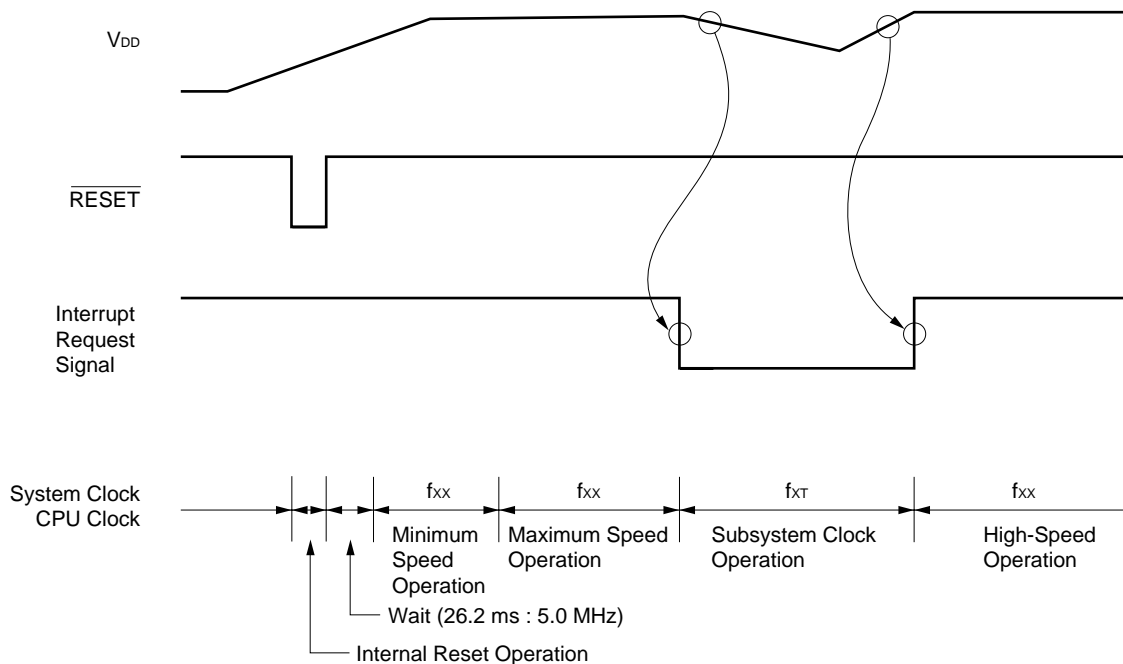
Caution Selection of the CPU clock cycle scaling factor (PCC0 to PCC2) and switchover from the main system clock to the subsystem clock (changing CSS from 0 to 1) should not be performed simultaneously. Simultaneous setting is possible, however, for selection of the CPU clock cycle scaling factor (PCC0 to PCC2) and switchover from the subsystem clock to the main system clock (changing CSS from 1 to 0).

Table 7-3. Maximum Time Required for CPU Clock Switchover

7.6.2 System clock and CPU clock switching procedure

This section describes switching procedure between system clock and CPU clock.

Figure 7-10. System Clock and CPU Clock Switching



- (1) The CPU is reset by setting the $\overline{\text{RESET}}$ signal to low level after power-on. After that, when reset is released by setting the $\overline{\text{RESET}}$ signal to high level, main system clock starts oscillation. At this time, oscillation stabilization time ($2^{17}/f_x$) is secured automatically. After that, the CPU starts executing the instruction at the minimum speed of the main system clock ($12.8 \mu\text{s}$ when operated at 5.0 MHz).
- (2) After the lapse of a sufficient time for the V_{DD} voltage to increase to enable operation at maximum speeds, the processor clock control register (PCC) and oscillation mode selection register (OSMS) are rewritten and the maximum-speed operation is carried out.
- (3) Upon detection of a decrease of the V_{DD} voltage due to an interrupt request signal, the main system clock is switched to the subsystem clock (which must be in an oscillation stable state).
- (4) Upon detection of V_{DD} voltage reset due to an interrupt request signal, 0 is set to the bit 7 (MCC) of PCC and oscillation of the main system clock is started. After the lapse of time required for stabilization of oscillation, the PCC and OSMS are rewritten and the maximum-speed operation is resumed.

Caution When subsystem clock is being operated while main system clock was stopped, if switching to the main system clock is made again, be sure to switch after securing oscillation stable time by software.

[MEMO]

CHAPTER 8 16-BIT TIMER/EVENT COUNTER

8.1 Outline of Timers Incorporated in the μ PD78054, 78054Y Subseries

This chapter explains 16-bit timer/event counter. Before that, the timers incorporated into the μ PD78054, 78054Y Subseries and related circuits are outlined below.

(1) 16-bit timer/event counter (TM0)

The TM0 can be used for an interval timer, PWM output, pulse widths measurement (infrared ray remote control receive function), external event counter, square wave output of any frequency or one-shot pulse output.

(2) 8-bit timers/event counters 1 and 2 (TM1 and TM2)

TM1 and TM2 can be used to serve as an interval timer and an external event counter and to output square waves with any selected frequency. Two 8-bit timer/event counters can be used as one 16-bit timer/event counter (See **CHAPTER 9 8-BIT TIMER/EVENT COUNTERS 1 AND 2**).

(3) Watch timer (TM3)

This timer can set a flag every 0.5 sec. and simultaneously generates interrupt requests at the preset time intervals (See **CHAPTER 10 WATCH TIMER**).

(4) Watchdog timer (WDTM)

WDTM can perform the watchdog timer function or generate non-maskable interrupt requests, maskable interrupt requests and $\overline{\text{RESET}}$ at the preset time intervals (See **CHAPTER 11 WATCHDOG TIMER**).

(5) Clock output control circuit

This circuit supplies other devices with the divided main system clock and the subsystem clock (See **CHAPTER 12 CLOCK OUTPUT CONTROL CIRCUIT**).

(6) Buzzer output control circuit

This circuit outputs the buzzer frequency obtained by dividing the main system clock (See **CHAPTER 13 BUZZER OUTPUT CONTROL CIRCUIT**).

Table 8-1. Timer/Event Counter Operations

		16-bit Timer/ event Counter	8-bit Timer/event Counters 1 and 2	Watch Timer	Watchdog Timer
Operating mode	Interval timer	2 channels ^{Note 3}	2 channels	1 channel ^{Note 1}	1 channel ^{Note 2}
	External event counter	√	√	—	—
Function	Timer output	√	√	—	—
	PWM output	√	—	—	—
	Pulse width measurement	√	—	—	—
	Square-wave output	√	√	—	—
	One-shot pulse output	√	—	—	—
	Interrupt source	√	√	√	√
	Test input	—	—	√	—

- Notes**
1. Watch timer can perform both watch timer and interval timer functions at the same time.
 2. Watchdog timer can perform either the watchdog timer function or the interval timer function.
 3. When capture/compare registers (CR00, CR01) are specified as compare registers.

8.2 16-Bit Timer/Event Counter Functions

The 16-bit timer/event counter (TM0) has the following functions.

- Interval timer
- PWM output
- Pulse width measurement
- External event counter
- Square-wave output
- One-shot pulse output

PWM output and pulse width measurement can be used at the same time.

(1) Interval timer

TM0 generates interrupt requests at the preset time interval.

Table 8-2. 16-Bit Timer/Event Counter Interval Times

Minimum Interval Time		Maximum Interval Time		Resolution	
MCS = 1	MCS = 0	MCS = 1	MCS = 0	MCS = 1	MCS = 0
2 × TI00 input cycle		2 ¹⁶ × TI00 input cycle		TI00 input edge cycle	
—	2 × 1/f _x (400 ns)	—	2 ¹⁶ × 1/f _x (13.1 ms)	—	1/f _x (200 ns)
2 × 1/f _x (400 ns)	2 ² × 1/f _x (800 ns)	2 ¹⁶ × 1/f _x (13.1 ms)	2 ¹⁷ × 1/f _x (26.2 ms)	1/f _x (200 ns)	2 × 1/f _x (400 ns)
2 ² × 1/f _x (800 ns)	2 ³ × 1/f _x (1.6 μs)	2 ¹⁷ × 1/f _x (26.2 ms)	2 ¹⁸ × 1/f _x (52.4 ms)	2 × 1/f _x (400 ns)	2 ² × 1/f _x (800 ns)
2 ³ × 1/f _x (1.6 μs)	2 ⁴ × 1/f _x (3.2 μs)	2 ¹⁸ × 1/f _x (52.4 ms)	2 ¹⁹ × 1/f _x (104.9 ms)	2 ² × 1/f _x (800 ns)	2 ³ × 1/f _x (1.6 μs)
2 × watch timer output cycle		2 ¹⁶ × watch timer output cycle		Watch timer output edge cycle	

- Remarks**
1. f_x: Main system clock oscillation frequency
 2. MCS: Oscillation mode selection register (OSMS) bit 0
 3. Values in parentheses when operated at f_x = 5.0 MHz

(2) PWM output

TM0 can generate 14-bit resolution PWM output.

(3) Pulse width measurement

TM0 can measure the pulse width of an externally input signal.

(4) External event counter

TM0 can measure the number of pulses of an externally input signal.

(5) Square-wave output

TM0 can output a square wave with any selected frequency.

Table 8-3. 16-Bit Timer/Event Counter Square-Wave Output Ranges

Minimum Pulse Width		Maximum Pulse Width		Resolution	
MCS = 1	MCS = 0	MCS = 1	MCS = 0	MCS = 1	MCS = 0
2 × T100 input cycle		2 ¹⁶ × T100 input cycle		T100 input edge cycle	
—	2 × 1/f _x (400 ns)	—	2 ¹⁶ × 1/f _x (13.1 ms)	—	1/f _x (200 ns)
2 × 1/f _x (400 ns)	2 ² × 1/f _x (800 ns)	2 ¹⁶ × 1/f _x (13.1 ms)	2 ¹⁷ × 1/f _x (26.2 ms)	1/f _x (200 ns)	2 × 1/f _x (400 ns)
2 ² × 1/f _x (800 ns)	2 ³ × 1/f _x (1.6 μs)	2 ¹⁷ × 1/f _x (26.2 ms)	2 ¹⁸ × 1/f _x (52.4 ms)	2 × 1/f _x (400 ns)	2 ² × 1/f _x (800 ns)
2 ³ × 1/f _x (1.6 μs)	2 ⁴ × 1/f _x (3.2 μs)	2 ¹⁸ × 1/f _x (52.4 ms)	2 ¹⁹ × 1/f _x (104.9 ms)	2 ² × 1/f _x (800 ns)	2 ³ × 1/f _x (1.6 μs)
2 × watch timer output cycle		2 ¹⁶ × watch timer output cycle		Watch timer output edge cycle	

- Remarks**
1. f_x: Main system clock oscillation frequency
 2. MCS: Oscillation mode selection register (OSMS) bit 0
 3. Values in parentheses when operated at f_x = 5.0 MHz

(6) One-shot pulse output

TM0 is able to output one-shot pulse which can set any width of output pulse.

8.3 16-Bit Timer/Event Counter Configuration

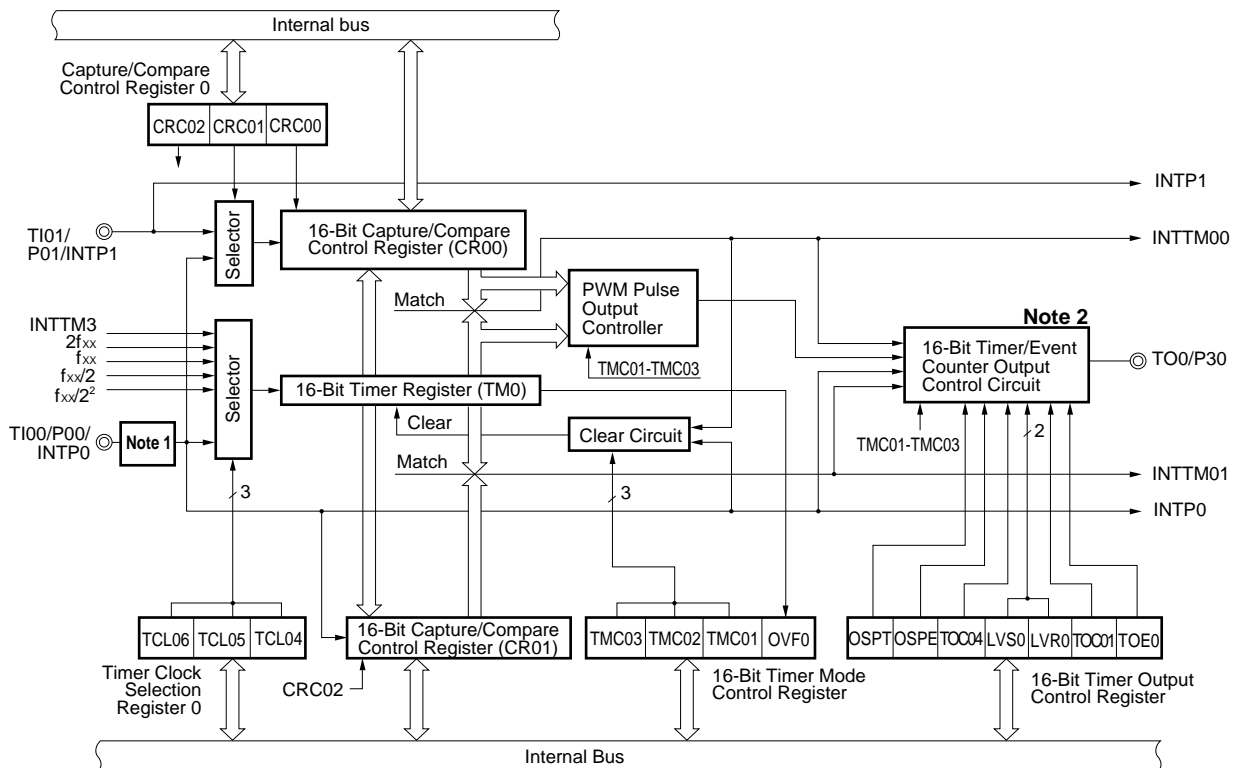
The 16-bit timer/event counter consists of the following hardware.

Table 8-4. 16-Bit Timer/Event Counter Configuration

Item	Configuration
Timer register	16 bits × 1 (TM0)
Register	Capture/compare register: 16 bits × 2 (CR00, CR01)
Timer output	1 (TO0)
Control register	Timer clock select register 0 (TCL0) 16-bit timer mode control register (TMC0) Capture/compare control register 0 (CRC0) 16-bit timer output control register (TOC0) Port mode register 3 (PM3) External interrupt mode register 0 (INTM0) Sampling clock select register (SCS) ^{Note}

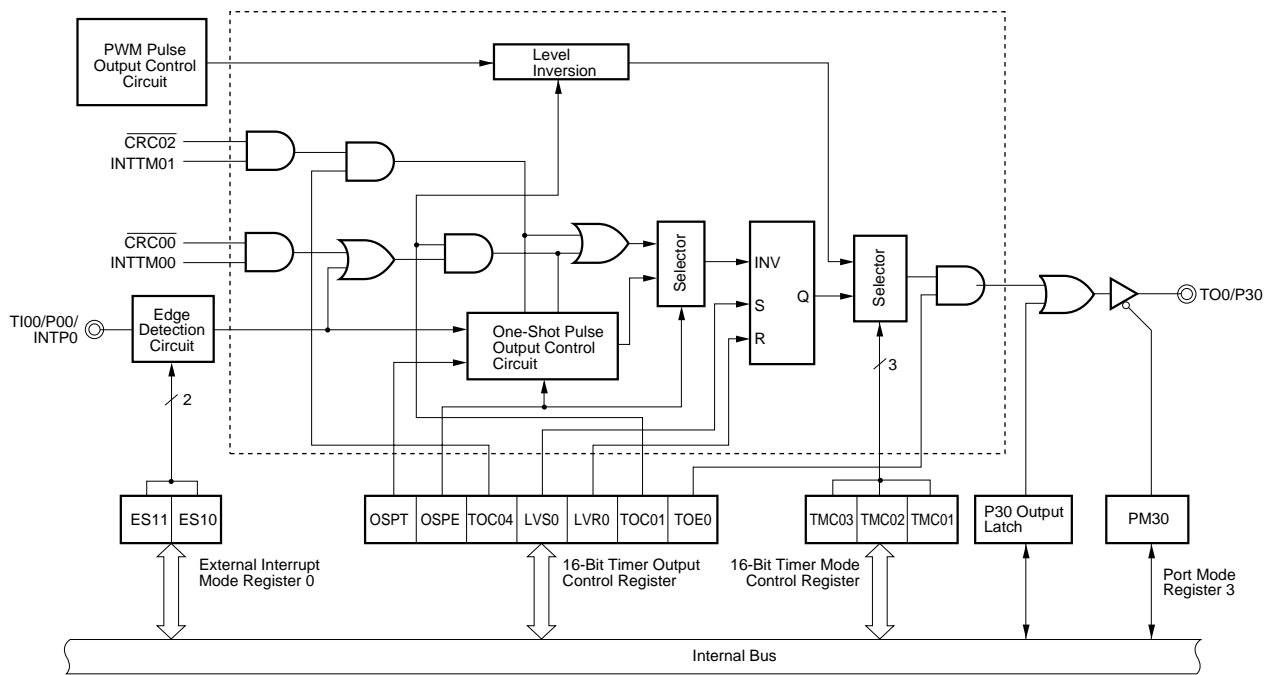
Note Refer to Figure 21-1. Basic Configuration of Interrupt Function.

Figure 8-1. 16-Bit Timer/Event Counter Block Diagram



- Notes**
1. Edge detection circuit
 2. The configuration of the 16-bit timer/event counter output control circuit is shown in Figure 8-2.

Figure 8-2. 16-Bit Timer/Event Counter Output Control Circuit Block Diagram



Remark The circuitry enclosed by the dotted line is the output control circuit.

(1) Capture/compare register 00 (CR00)

CR00 is a 16-bit register which has the functions of both a capture register and a compare register. Whether it is used as a capture register or as a compare register is set by bit 0 (CRC00) of capture/compare control register 0 (CRC0).

When CR00 is used as a compare register, the value set in the CR00 is constantly compared with the 16-bit timer register (TM0) count value, and an interrupt request (INTTM00) is generated if they match. It can also be used as the register which holds the interval time when TM0 is set to interval timer operation, and it can be used as the register which sets the pulse width when TM0 is set to PWM output operation.

When CR00 is used as a capture register, it is possible to select the valid edge of the INTP0/TI00 pin or the INTP1/TI01 pin as the capture trigger. The INTP0/TI00 or INTP1/TI01 valid edge is set by means of external interrupt mode register 0 (INTM0).

If CR00 is specified as a capture register and capture trigger is specified to be the valid edge of the INTP0/TI00 pin, the situation is as shown in the following table.

Table 8-5. INTP0/TI00 Pin Valid Edge and CR00 Capture Trigger Valid Edge

ES11	ES10	INTP0/TI00 Pin Valid Edge	CR00 Capture Trigger Valid Edge
0	0	Falling edge	Rising edge
0	1	Rising edge	Falling edge
1	0	Setting prohibited	
1	1	Both rising and falling edges	No capture operation

CR00 is set by a 16-bit memory manipulation instruction.

After $\overline{\text{RESET}}$ input, the value of CR00 is undefined.

- Cautions**
- 1. Set the data of PWM (14 bits) to the higher 14 bits of CR00. At this time, clear the lower 2 bits to 00.**
 - 2. Set a value other than 0000H to CR00. When the event counter function is used, therefore, one pulse cannot be counted.**
 - 3. If the new value of CR00 is less than the value of the 16-bit timer register (TM0), TM0 continues counting, overflows, and then starts counting again from 0. If the new value of CR00 is less than the old value, the timer must be restarted after changing the value of CR00.**

(2) Capture/compare register 01 (CR01)

CR01 is a 16-bit register which has the functions of both a capture register and a compare register. Whether it is used as a capture register or a compare register is set by bit 2 (CRC02) of capture/compare control register 0.

When CR01 is used as a compare register, the value set in the CR01 is constantly compared with the 16-bit timer register (TM0) count value, and an interrupt request (INTTM01) is generated if they match.

When CR01 is used as a capture register, it is possible to select the valid edge of the INTP0/TI00 pin as the capture trigger. The INTP0/TI00 valid edge is set by means of external interrupt mode register 0 (INTM0).

CR01 is set with a 16-bit memory manipulation instruction.

After $\overline{\text{RESET}}$ input, the value of CR01 is undefined.

Caution If the valid edge of the TIO0/P00 pin is input while CR01 is read, CR01 does not perform the capture operation and retains the current data. However, the interrupt request flag (PIF0) is set.

(3) 16-bit timer register (TM0)

TM0 is a 16-bit register which counts the count pulses.

TM0 is read by a 16-bit memory manipulation instruction. When TM0 is read, capture/compare register 01 (CR01) should first be set as a capture register.

$\overline{\text{RESET}}$ input sets TM0 to 0000H.

Caution As the value of TM0 is read via CR01, the value of CR01 previously set is lost.

8.4 16-Bit Timer/Event Counter Control Registers

The following seven types of registers are used to control the 16-bit timer/event counter.

- Timer clock select register 0 (TCL0)
- 16-bit timer mode control register (TMC0)
- Capture/compare control register 0 (CRC0)
- 16-bit timer output control register (TOC0)
- Port mode register 3 (PM3)
- External interrupt mode register 0 (INTM0)
- Sampling clock select register (SCS)

(1) Timer clock select register 0 (TCL0)

This register is used to set the count clock of the 16-bit timer register.

TCL0 is set with a 1-bit or 8-bit memory manipulation instruction.

$\overline{\text{RESET}}$ input sets TCL0 value to 00H.

Remark TCL0 has the function of setting the PCL output clock in addition to that of setting the count clock of the 16-bit timer register.

Figure 8-3. Timer Clock Selection Register 0 Format

Symbol	<7>	6	5	4	3	2	1	0	Address	After Reset	R/W
TCL0	CLOE	TCL06	TCL05	TCL04	TCL03	TCL02	TCL01	TCL00	FF40H	00H	R/W

TCL03	TCL02	TCL01	TCL00	PCL Output Clock Selection		
				MCS = 1		MCS = 0
0	0	0	0	f _{XT} (32.768 kHz)		
0	1	0	1	f _{XX}	f _X (5.0 MHz)	f _X /2 (2.5 MHz)
0	1	1	0	f _{XX} /2	f _X /2 (2.5 MHz)	f _X /2 ² (1.25 MHz)
0	1	1	1	f _{XX} /2 ²	f _X /2 ² (1.25 MHz)	f _X /2 ³ (625 kHz)
1	0	0	0	f _{XX} /2 ³	f _X /2 ³ (625 kHz)	f _X /2 ⁴ (313 kHz)
1	0	0	1	f _{XX} /2 ⁴	f _X /2 ⁴ (313 kHz)	f _X /2 ⁵ (156 kHz)
1	0	1	0	f _{XX} /2 ⁵	f _X /2 ⁵ (156 kHz)	f _X /2 ⁶ (78.1 kHz)
1	0	1	1	f _{XX} /2 ⁶	f _X /2 ⁶ (78.1 kHz)	f _X /2 ⁷ (39.1 kHz)
1	1	0	0	f _{XX} /2 ⁷	f _X /2 ⁷ (39.1 kHz)	f _X /2 ⁸ (19.5 kHz)
Other than above				Setting prohibited		

TCL06	TCL05	TCL04	16-Bit Timer Register Count Clock Selection		
			MCS = 1		MCS = 0
0	0	0	TI00 (Valid edge specifiable)		
0	0	1	2f _{XX}	Setting prohibited	f _X (5.0 MHz)
0	1	0	f _{XX}	f _X (5.0 MHz)	f _X /2 (2.5 MHz)
0	1	1	f _{XX} /2	f _X /2 (2.5 MHz)	f _X /2 ² (1.25 MHz)
1	0	0	f _{XX} /2 ²	f _X /2 ² (1.25 MHz)	f _X /2 ³ (625 kHz)
1	1	1	Watch timer output (INTTM 3)		
Other than above			Setting prohibited		

CLOE	PCL Output Control
0	Output disabled
1	Output enabled

- Cautions**
1. The TI00/INTP0 pin valid edge is set by external interrupt mode register 0 (INTM0), and the sampling clock frequency is selected by the sampling clock selection register (SCS).
 2. When enabling PCL output, set TCL00 to TCL03, then set 1 in CLOE with a 1-bit memory manipulation instruction.
 3. To read the count value when TI00 has been specified as the TM0 count clock, the value should be read from TM0, not from 16-bit capture/compare register 01 (CR01).
 4. When rewriting TCL0 to other data, stop the timer operation beforehand.

- Remarks**
1. f_{xx} : Main system clock frequency (f_x or $f_x/2$)
 2. f_x : Main system clock oscillation frequency
 3. f_{xT} : Subsystem clock oscillation frequency
 4. TI00 : 16-bit timer/event counter input pin
 5. TM0 : 16-bit timer register
 6. MCS : Bit 0 of oscillation mode selection register (OSMS)
 7. Figures in parentheses apply to operation with $f_x = 5.0$ MHz of $f_{xT} = 32.768$ kHz.

(2) 16-bit timer mode control register (TMC0)

This register sets the 16-bit timer operating mode, the 16-bit timer register clear mode and output timing, and detects an overflow.

TMC0 is set with a 1-bit or 8-bit memory manipulation instruction.

$\overline{\text{RESET}}$ input sets TMC0 value to 00H.

Caution The 16-bit timer register starts operation at the moment a value other than 0, 0, 0 (operation stop mode) is set in TMC01 to TMC03, respectively. Set 0, 0, 0 in TMC01 to TMC03 to stop the operation.

Figure 8-4. 16-Bit Timer Mode Control Register Format

Symbol	7	6	5	4	3	2	1	<0>	Address	After Reset	R/W
TMC0	0	0	0	0	TMC03	TMC02	TMC01	OVF0	FF48H	00H	R/W

OVF0	16-Bit Timer Register Overflow Detection
0	Overflow not detected
1	Overflow detected

TMC03	TMC02	TMC01	Operating Mode Clear Mode Selection	TO0 Output Timing Selection	Interrupt Generation
0	0	0	Operation stop (TM0 cleared to 0)	No change	Not Generated
0	0	1	PWM mode (free running)	PWM pulse output	Generated on match between TM0 and CR00, or match between TM0 and CR01
0	1	0	Free running mode	Match between TM0 and CR00 or match between TM0 and CR01	
0	1	1		Match between TM0 and CR00, match between TM0 and CR01 or TI00 valid edge	
1	0	0	Clear & start on TI00 valid edge	Match between TM0 and CR00 or match between TM0 and CR01	
1	0	1		Match between TM0 and CR00, match between TM0 and CR01 or TI00 valid edge	
1	1	0	Clear & start on match between TM0 and CR00	Match between TM0 and CR00 or match between TM0 and CR01	
1	1	1		Match between TM0 and CR00, match between TM0 and CR01 or TI00 valid edge	

★

- Remarks**
1. TO0 : 16-bit timer/event counter output pin
 2. TI00 : 16-bit timer/event counter input pin
 3. TM0 : 16-bit timer register
 4. CR00 : Compare register 00
 5. CR01 : Compare register 01

- Cautions**
1. Switch the clear mode and the T00 output timing after stopping the timer operation (by setting TMC01 to TMC03 to 0, 0, 0).
 2. Set the valid edge of the TI00/INTP0 pin with an external interrupt mode register 0 (INTM0) and select the sampling clock frequency with a sampling clock select register (SCS).
 3. When using the PWM mode, set the PWM mode and then set data to CR00.
 4. If clear & start mode on match between TM0 and CR00 is selected, when the set value of CR00 is FFFFH and the TM0 value changes from FFFFH to 0000H, OVF0 flag is set to 1.

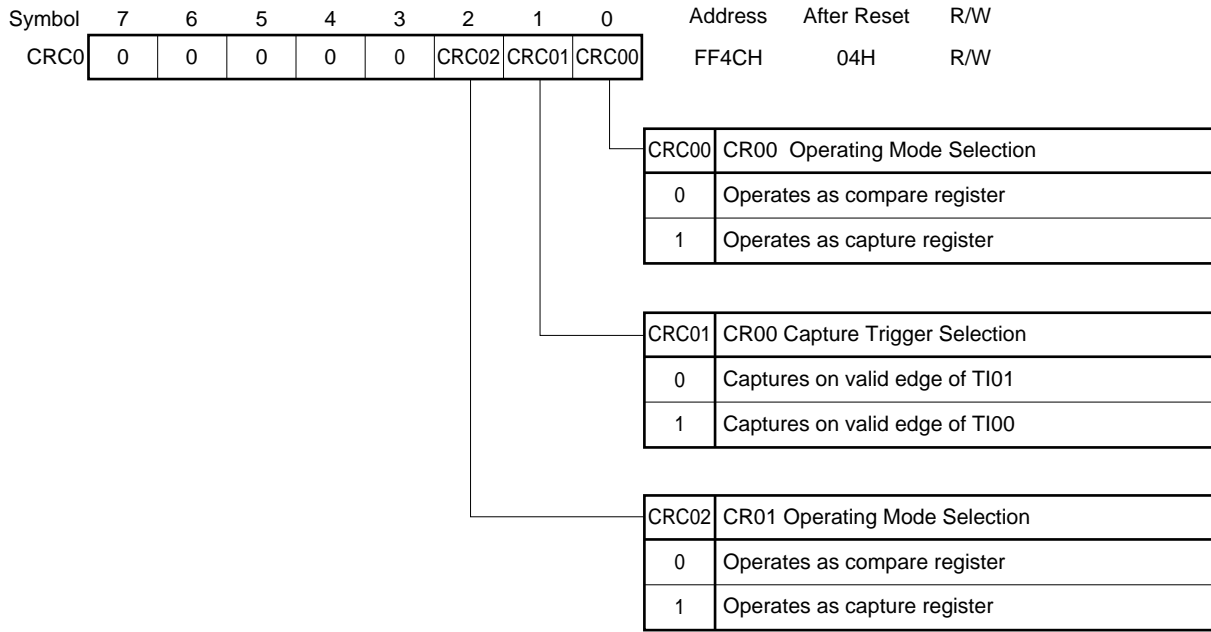
(3) Capture/compare control register 0 (CRC0)

This register controls the operation of the capture/compare registers (CR00, CR01).

CRC0 is set with a 1-bit or 8-bit memory manipulation instruction.

$\overline{\text{RESET}}$ input sets CRC0 value to 04H.

Figure 8-5. Capture/Compare Control Register 0 Format



Cautions 1. Timer operation must be stopped before setting CRC0.

2. When clear & start mode on a match between TM0 and CR00 is selected with the 16-bit timer mode control register, CR00 should not be specified as a capture register.

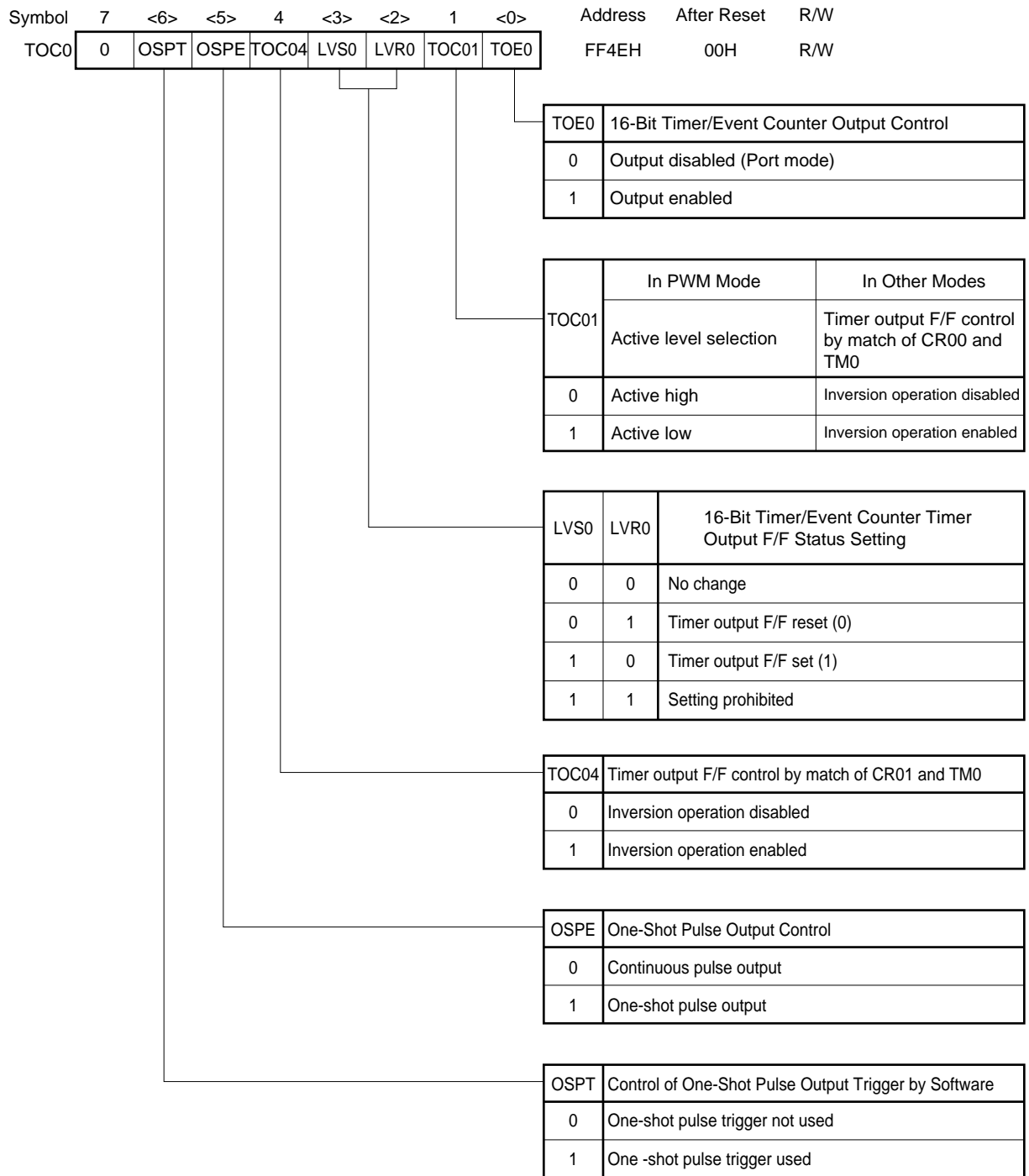
(4) 16-bit timer output control register (TOC0)

This register controls the operation of the 16-bit timer/event counter output control circuit. It sets R-S type flip-flop (LV0) setting/resetting, the active level in PWM mode, inversion enabling/disabling in modes other than PWM mode, 16-bit timer/event counter timer output enabling/disabling, one-shot pulse output operation enabling/disabling, and output trigger for a one-shop pulse by software.

TOC0 is set with a 1-bit or 8-bit memory manipulation instruction.

$\overline{\text{RESET}}$ input sets TOC0 value to 00H.

Figure 8-6. 16-Bit Timer Output Control Register Format



- Cautions**
1. Timer operation must be stopped before setting TOC0 (however, except OSPT).
 2. If LVS0 and LVR0 are read after data is set, they will be 0.
 3. OSPT is cleared automatically after data setting, and will therefore be 0 if read.

(5) Port mode register 3 (PM3)

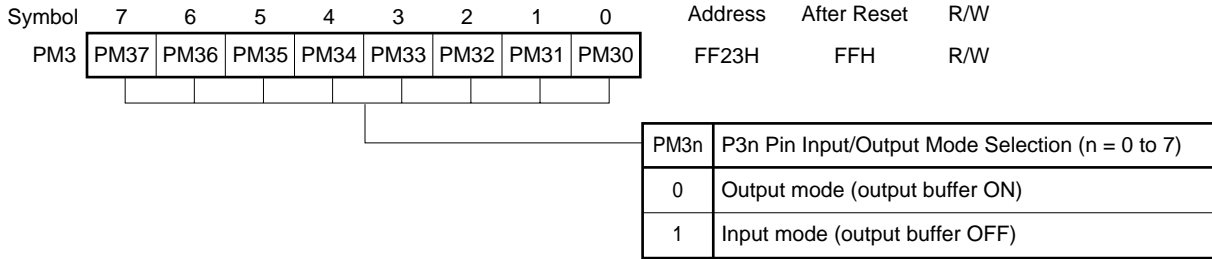
This register sets port 3 input/output in 1-bit units.

When using the P30/TO0 pin for timer output, set PM30 and output latch of P30 to 0.

PM3 is set with a 1-bit or 8-bit memory manipulation instruction.

RESET input sets PM3 value to FFH.

Figure 8-7. Port Mode Register 3 Format



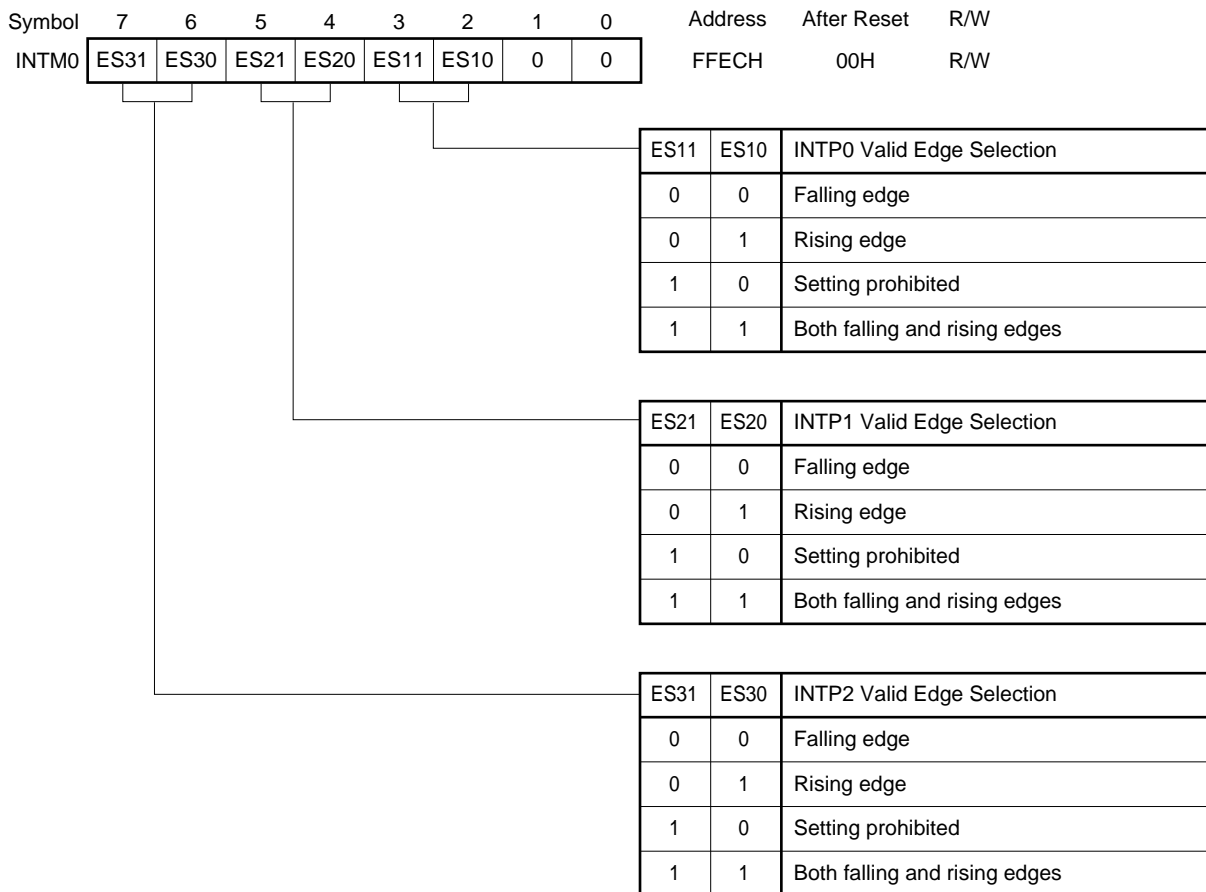
(6) External interrupt mode register 0 (INTM0)

This register is used to set INTP0 to INTP2 valid edges.

INTM0 is set with an 8-bit memory manipulation instruction.

$\overline{\text{RESET}}$ input sets INTM0 value to 00H.

Figure 8-8. External Interrupt Mode Register 0 Format



Caution Before setting the valid edge of the INTP0/TI00/P00 pin, stop the timer operation by clearing the bits 1 through 3 (TMC01 through TMC03) of the 16-bit timer mode control register (TMC0) to 0, 0, 0.

(7) Sampling clock select registers (SCS)

This register sets clocks which undergo clock sampling of valid edges to be input to INTP0. When remote controlled reception is carried out using INTP0, digital noise is removed with sampling clock.

SCS is set with an 8-bit memory manipulation instruction.

RESET input sets SCS value to 00H.

Figure 8-9. Sampling Clock Select Register Format



Caution $f_{xx}/2^N$ is the clock supplied to the CPU, and $f_{xx}/2^5$, $f_{xx}/2^6$, and $f_{xx}/2^7$ are clocks supplied to peripheral hardware. $f_{xx}/2^N$ is stopped in HALT mode.

- Remarks**
1. N : Value set in bits 0 to 2 (PCC0 to PCC2) of the processor clock control register (PCC) (N = 0 to 4)
 2. f_{xx} : Main system clock frequency (fx or fx/2)
 3. f_x : Main system clock oscillation frequency
 4. MCS : Bit 0 of oscillation mode selection register (OSMS)
 5. Figures in parentheses apply to operation with $f_x = 5.0$ MHz.

8.5 16-Bit Timer/Event Counter Operations

8.5.1 Interval timer operations

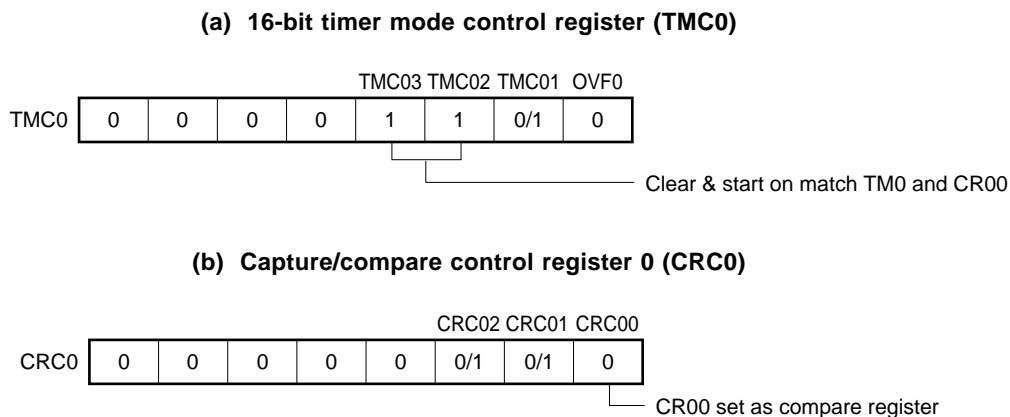
Setting the 16-bit timer mode control register (TMC0) and capture/compare control register 0 (CRC0) as shown in Figure 8-10 allows operation as an interval timer. Interrupt requests are generated repeatedly using the count value set in 16-bit capture/compare register 00 (CR00) beforehand as the interval.

When the count value of the 16-bit timer register (TM0) matches the value set to CR00, counting continues with the TM0 value cleared to 0 and the interrupt request signal (INTTM00) is generated.

Count clock of the 16-bit timer/event counter can be selected with bits 4 to 6 (TCL04 to TCL06) of the timer clock select register 0 (TCL0).

For the operation when the value of the compare register is changed during the timer count operation, refer to **8.6 16-Bit Timer/Event Counter Precautions (3)**.

Figure 8-10. Control Register Settings for Interval Timer Operation



Remark 0/1 : Setting 0 or 1 allows another function to be used simultaneously with the interval timer. See the description of the respective control registers for details.

Figure 8-11. Interval Timer Configuration Diagram

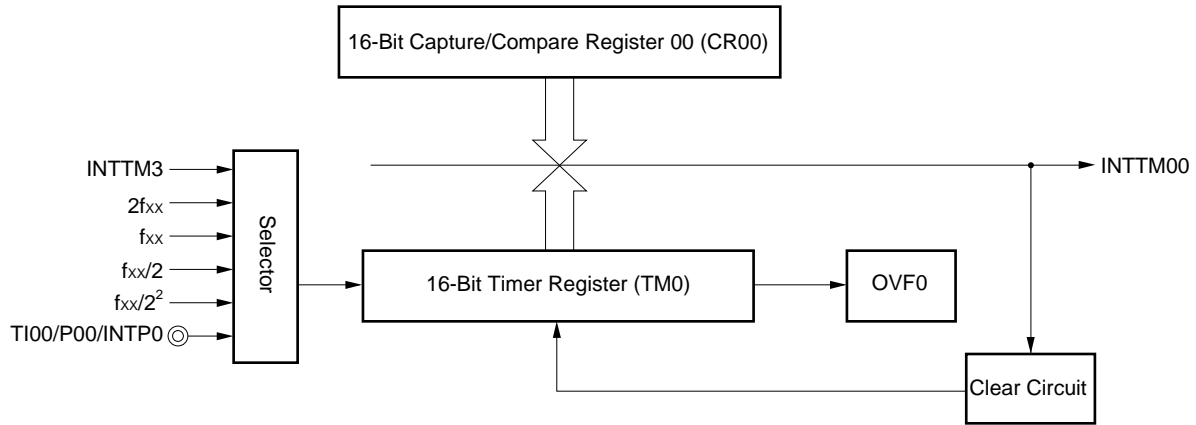
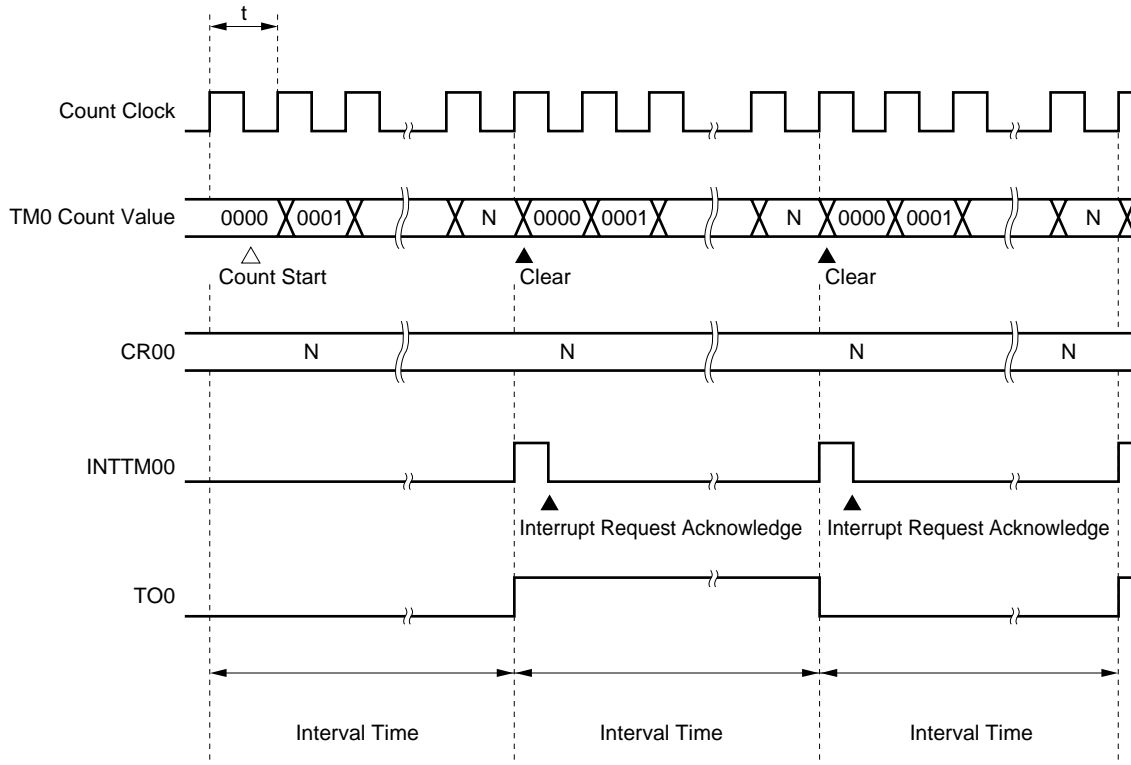


Figure 8-12. Interval Timer Operation Timings



Remark Interval time = $(N + 1) \times t$: $N = 0001H$ to $FFFFH$.

Table 8-6. 16-Bit Timer/Event Counter Interval Times

TCL06	TCL05	TCL04	Minimum Interval Time		Maximum Interval Time		Resolution	
			MCS = 1	MCS = 0	MCS = 1	MCS = 0	MCS = 1	MCS = 0
0	0	0	2 × TI00 input cycle		2 ¹⁶ × TI00 input cycle		TI00 input edge cycle	
0	0	1	Setting prohibited	2 × 1/fx (400 ns)	Setting prohibited	2 ¹⁶ × 1/fx (13.1 ms)	Setting prohibited	1/fx (200 ns)
0	1	0	2 × 1/fx (400 ns)	2 ² × 1/fx (800 ns)	2 ¹⁶ × 1/fx (13.1 ms)	2 ¹⁷ × 1/fx (26.2 ms)	1/fx (200 ns)	2 × 1/fx (400 ns)
0	1	1	2 ² × 1/fx (800 ns)	2 ³ × 1/fx (1.6 μs)	2 ¹⁷ × 1/fx (26.2 ms)	2 ¹⁸ × 1/fx (52.4 ms)	2 × 1/fx (400 ns)	2 ² × 1/fx (800 ns)
1	0	0	2 ³ × 1/fx (1.6 μs)	2 ⁴ × 1/fx (3.2 μs)	2 ¹⁸ × 1/fx (52.4 ms)	2 ¹⁹ × 1/fx (104.9 ms)	2 ² × 1/fx (800 ns)	2 ³ × 1/fx (1.6 μs)
1	1	1	2 × watch timer output cycle		2 ¹⁶ × watch timer output cycle		Watch timer output edge cycle	
Other than above			Setting prohibited					

- Remarks**
1. f_x : Main system clock oscillation frequency
 2. MCS : Bit 0 of oscillation mode selection register (OSMS)
 3. TCL04 to TCL06 : Bits 4 to 6 of timer clock select register 0 (TCL0)
 4. Figures in parentheses apply to operation with $f_x = 5.0$ MHz

8.5.2 PWM output operations

Setting the 16-bit timer mode control register (TMC0), capture/compare control register 0 (CRC0), and the 16-bit timer output control register (TOC0) as shown in Figure 8-13 allows operation as PWM output. Pulses with the duty rate determined by the value set in 16-bit capture/compare register 00 (CR00) beforehand are output from the TO0/P30 pin.

Set the active level width of the PWM pulse to the high-order 14 bits of CR00. Select the active level with bit 1 (TOC01) of the 16-bit timer output control register (TOC0).

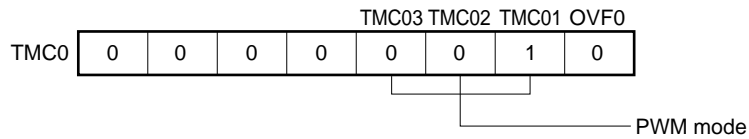
This PWM pulse has a 14-bit resolution. The pulse can be converted to an analog voltage by integrating it with an external low-pass filter (LPF). The PWM pulse is formed by a combination of the basic cycle determined by $2^8/\Phi$ and the sub-cycle determined by $2^{14}/\Phi$ so that the time constant of the external LPF can be shortened. Count clock Φ can be selected with bits 4 to 6 (TCL04 to TCL06) of the timer clock select register 0 (TCL0).

PWM output enable/disable can be selected with bit 0 (TOE0) of TOC0.

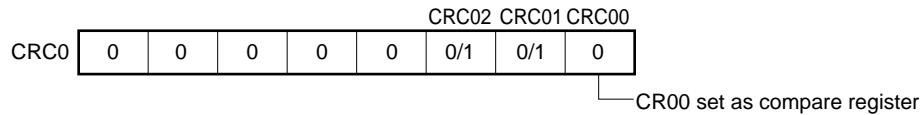
- Cautions**
1. PWM operation mode should be selected before setting CR00.
 2. Be sure to write 0 to bits 0 and 1 of CR00.
 3. Do not select PWM operation mode for external clock input from the TI00/P00/INTP0 pin.

Figure 8-13. Control Register Settings for PWM Output Operation

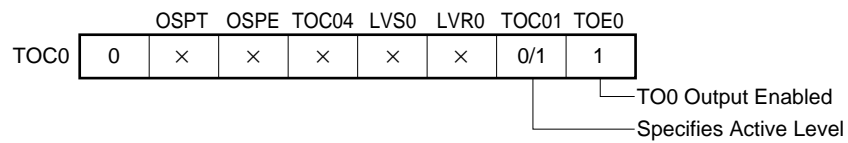
(a) 16-bit timer mode control register (TMC0)



(b) Capture/compare control register 0 (CRC0)



(c) 16-bit timer output control register (TOC0)



Remark 0/1 : Setting 0 or 1 allows another function to be used simultaneously with PWM output.

See the description of the respective control registers for details.

× : Don't care

By integrating 14-bit resolution PWM pulses with an external low-pass filter, they can be converted to an analog voltage and used for electronic tuning and D/A converter applications, etc.

The analog output voltage (V_{AN}) used for D/A conversion with the configuration shown in Figure 8-14 is as follows.

$$V_{AN} = V_{REF} \times \frac{\text{capture/compare register 00 (CR00) value}}{2^{16}}$$

V_{REF} : External switching circuit reference voltage

Figure 8-14. Example of D/A Converter Configuration with PWM Output

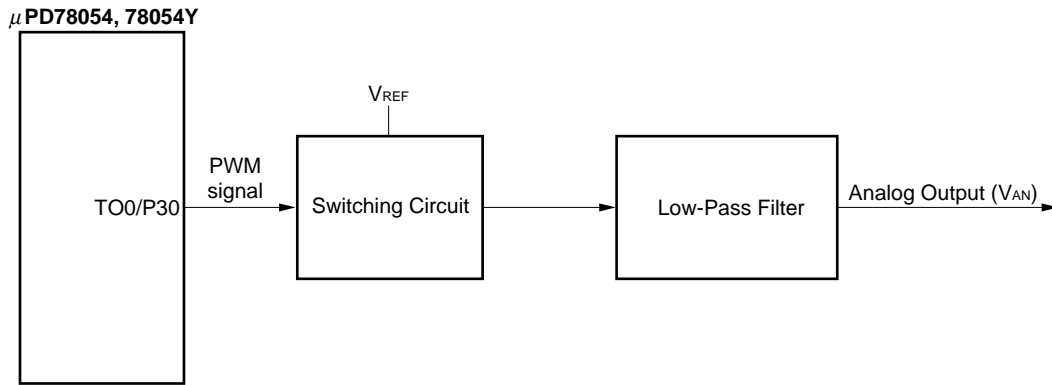
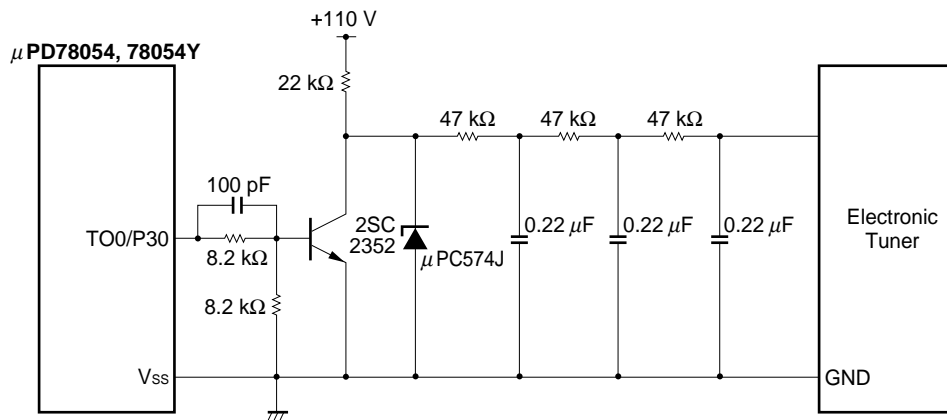


Figure 8-15 shows an example in which PWM output is converted to an analog voltage and used in a voltage synthesizer type TV tuner.

Figure 8-15. TV Tuner Application Circuit Example

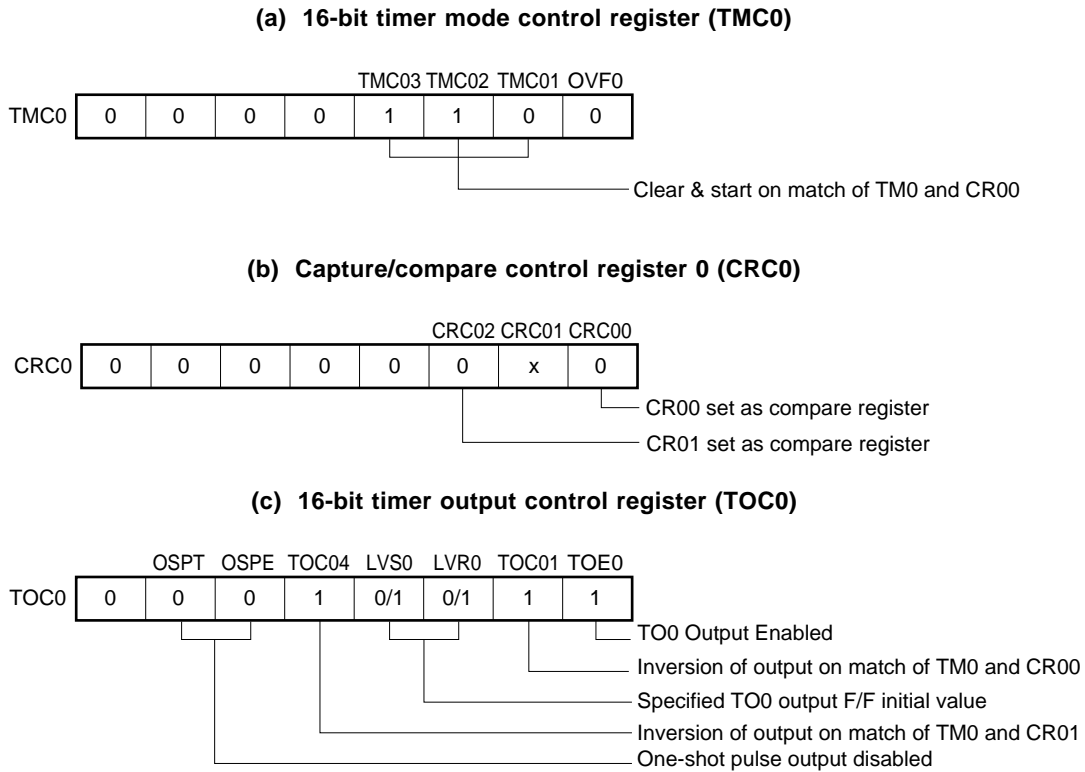


8.5.3 PPG output operations

Setting the 16-bit timer mode control register (TMC0) and capture/compare control register 0 (CRC0) as shown in Figure 8-16 allows operation as PPG (Programmable Pulse Generator) output.

In the PPG output operation, square waves are output from the TO0/P30 pin with the pulse width and the cycle that correspond to the count values set beforehand in 16-bit capture/compare register 01 (CR01) and in 16-bit capture/compare register 00 (CR00), respectively.

Figure 8-16. Control Register Settings for PPG Output Operation



Caution Values in the following range should be set in CR00 and CR01:
 $0000H \leq CR01 < CR00 \leq FFFFH$

Remark × : Don't care

8.5.4 Pulse width measurement operations

It is possible to measure the pulse width of the signals input to the TI00/P00 pin and TI01/P01 pin using the 16-bit timer register (TM0).

There are two measurement methods: measuring with TM0 used in free-running mode, and measuring by restarting the timer in synchronization with the edge of the signal input to the TI00/P00 pin.

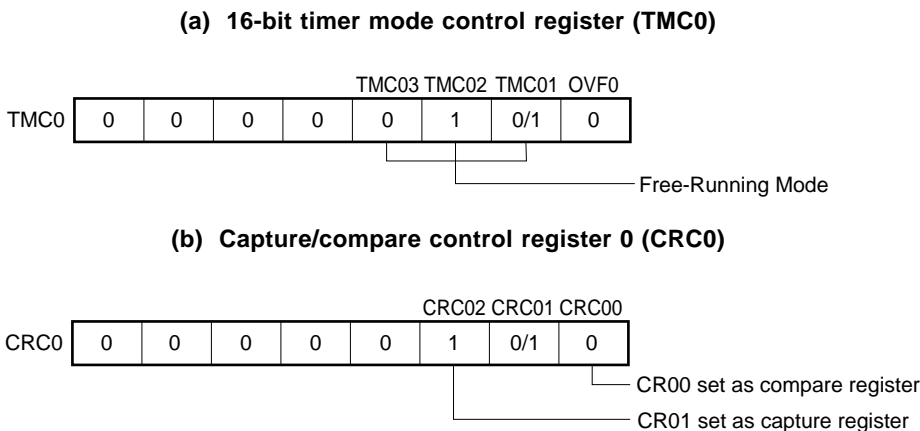
(1) Pulse width measurement with free-running counter and one capture register

When the 16-bit timer register (TM0) is operated in free-running mode (see register settings in Figure 8-17), and the edge specified by external interrupt mode register 0 (INTM0) is input to the TI00/P00 pin, the value of TM0 is taken into 16-bit capture/compare register 01 (CR01) and an external interrupt request signal (INTP0) is set.

Any of three edge specifications can be selected—rising, falling, or both edges—by means of bits 2 and 3 (ES10 and ES11) of INTM0.

For valid edge detection, sampling is performed at the interval selected by means of the sampling clock selection register (SCS), and a capture operation is only performed when a valid level is detected twice, thus eliminating noise with a short pulse width.

Figure 8-17. Control Register Settings for Pulse Width Measurement with Free-Running Counter and One Capture Register



Remark 0/1: Setting 0 or 1 allows another function to be used simultaneously with pulse width measurement. See the description of the respective control registers for details.

Figure 8-18. Configuration Diagram for Pulse Width Measurement by Free-Running Counter

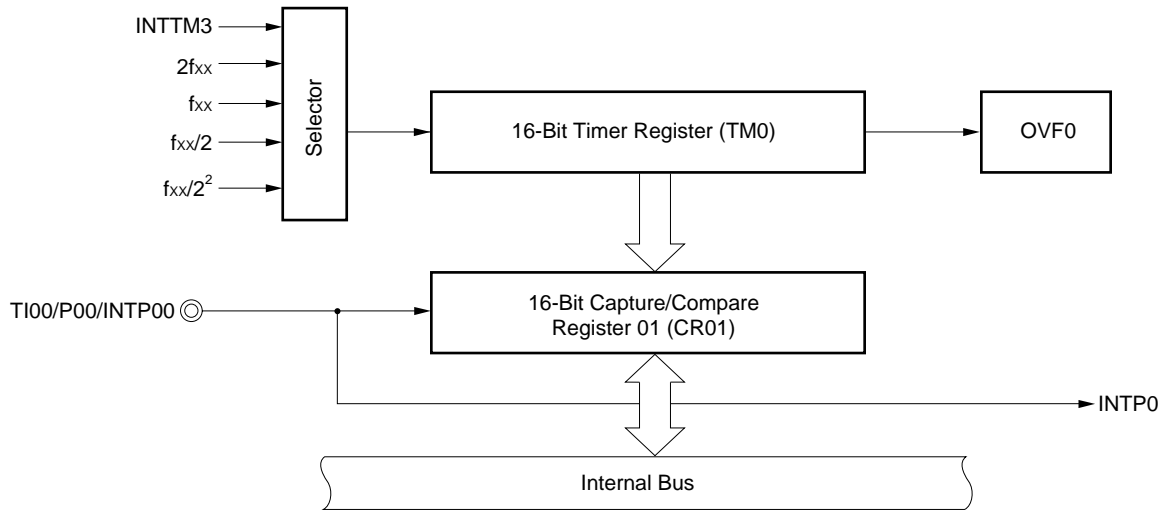
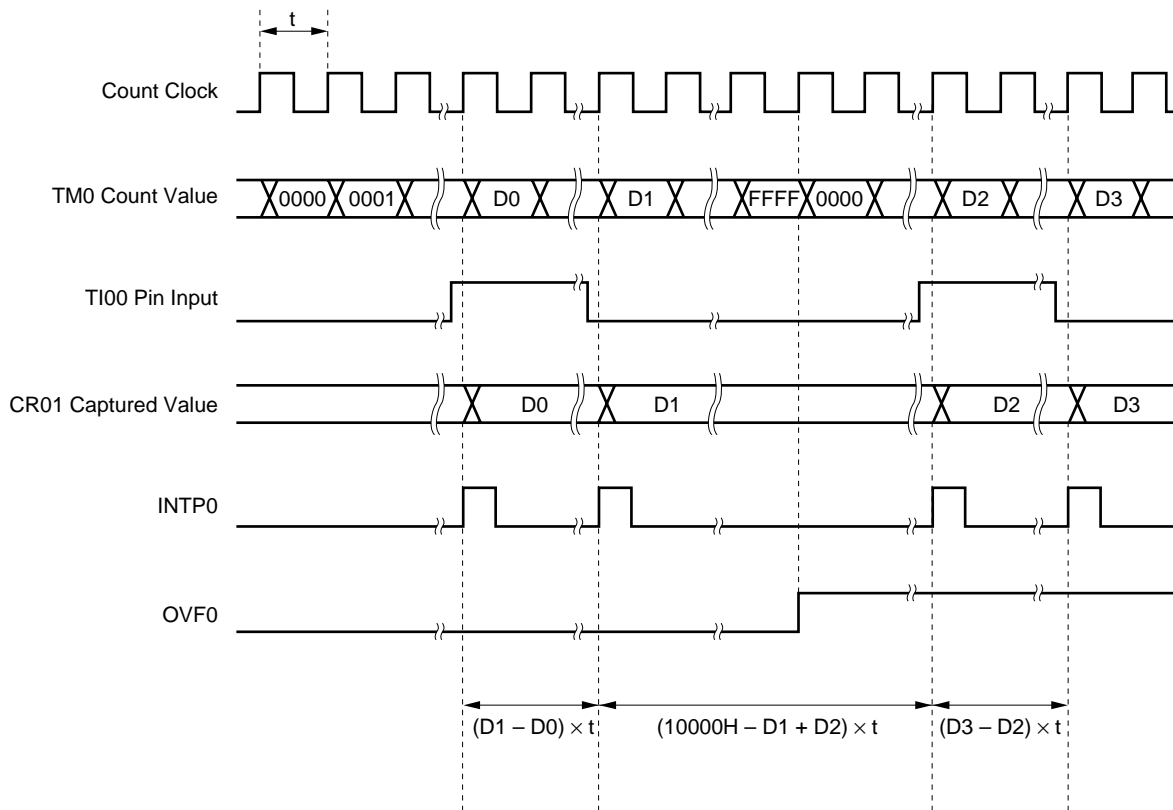


Figure 8-19. Timing of Pulse Width Measurement Operation by Free-Running Counter and One Capture Register (with Both Edges Specified)



(2) Measurement of two pulse widths with free-running counter

When the 16-bit timer register (TM0) is operated in free-running mode (see register settings in Figure 8-20), it is possible to simultaneously measure the pulse widths of the two signals input to the TI00/P00 pin and the TI01/P01 pin.

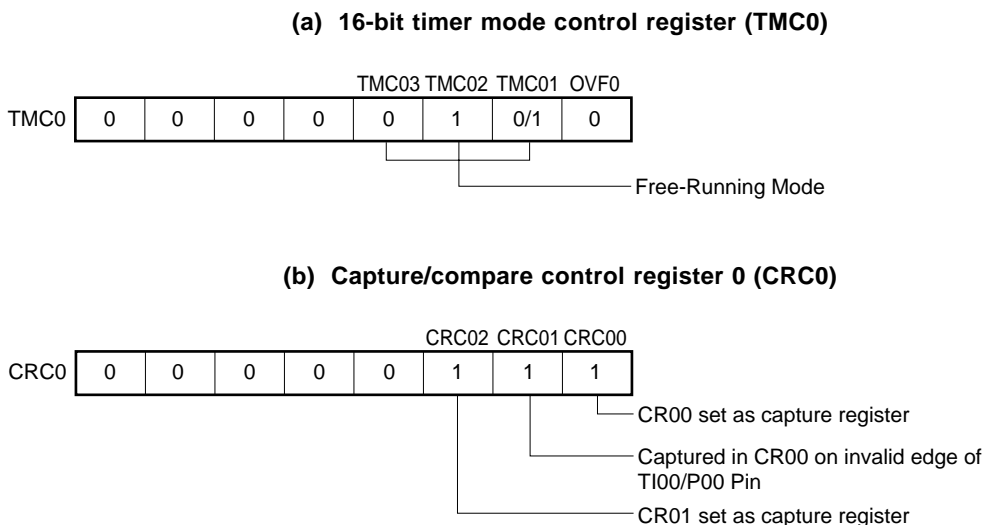
When the edge specified by bits 2 and 3 (ES10 and ES11) of external interrupt mode register 0 (INTM0) is input to the TI00/P00 pin, the value of TM0 is taken into 16-bit capture/compare register 01 (CR01) and an external interrupt request signal (INTP0) is set.

Also, when the edge specified by bits 4 and 5 (ES20 and ES21) of INTM0 is input to the TI01/P01 pin, the value of TM0 is taken into 16-bit capture/compare register 00 (CR00) and an external interrupt request signal (INTP1) is set.

Any of three edge specifications can be selected—rising, falling, or both edges—as the valid edges for the TI00/P00 pin and the TI01/P01 pin by means of bits 2 and 3 (ES10 and ES11) and bits 4 and 5 (ES20 and ES21) of INTM0, respectively.

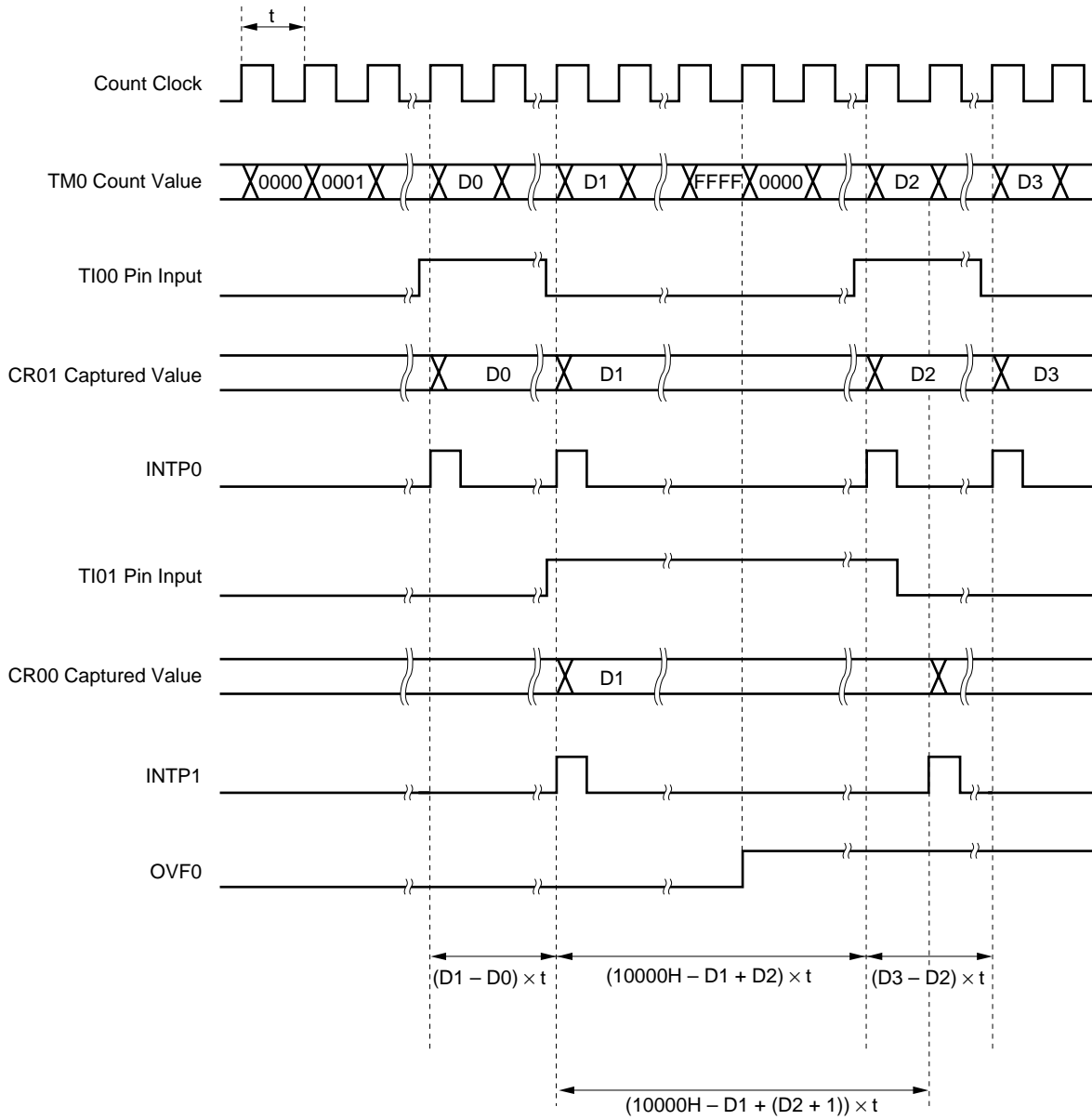
For TI00/P00 pin valid edge detection, sampling is performed at the interval selected by means of the sampling clock selection register (SCS), and a capture operation is only performed when a valid level is detected twice, thus eliminating noise with a short pulse width.

Figure 8-20. Control Register Settings for Two Pulse Width Measurements with Free-Running Counter



Remark 0/1: Setting 0 or 1 allows another function to be used simultaneously with pulse width measurement. See the description of the respective control registers for details.

Figure 8-21. Timing of Pulse Width Measurement Operation with Free-Running Counter (with Both Edges Specified)



(3) Pulse width measurement with free-running counter and two capture registers

When the 16-bit timer register (TM0) is operated in free-running mode (see register settings in Figure 8-22), it is possible to measure the pulse width of the signal input to the TI00/P00 pin.

When the edge specified by bits 2 and 3 (ES10 and ES11) of external interrupt mode register 0 (INTM0) is input to the TI00/P00 pin, the value of TM0 is taken into 16-bit capture/compare register 01 (CR01) and an external interrupt request signal (INTP0) is set.

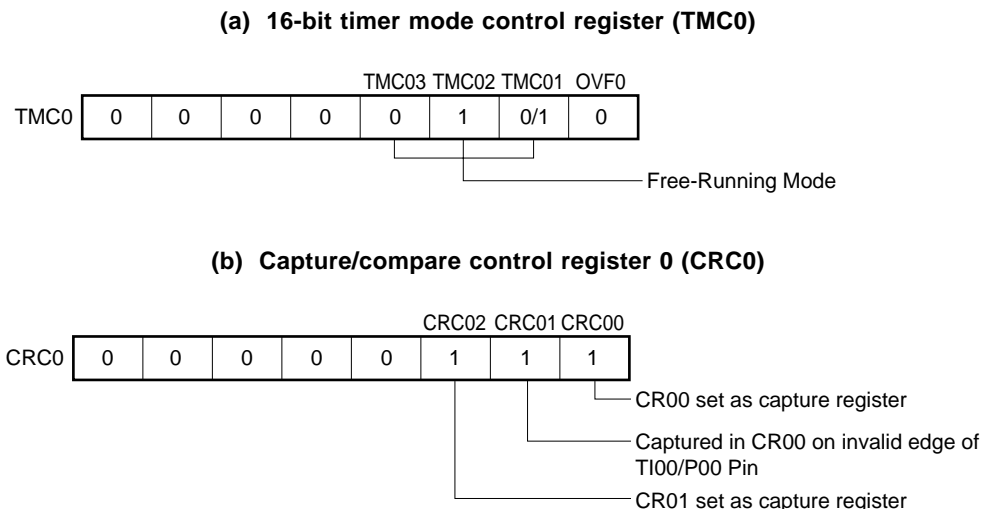
Also, on the inverse edge input of that of the capture operation into CR01, the value of TM0 is taken into 16-bit capture/compare register 00 (CR00).

Either of two edge specifications can be selected—rising or falling—as the valid edges for the TI00/P00 pin by means of bits 2 and 3 (ES10 and ES11) of INTM0.

For TI00/P00 pin valid edge detection, sampling is performed at the interval selected by means of the sampling clock selection register (SCS), and a capture operation is only performed when a valid level is detected twice, thus eliminating noise with a short pulse width.

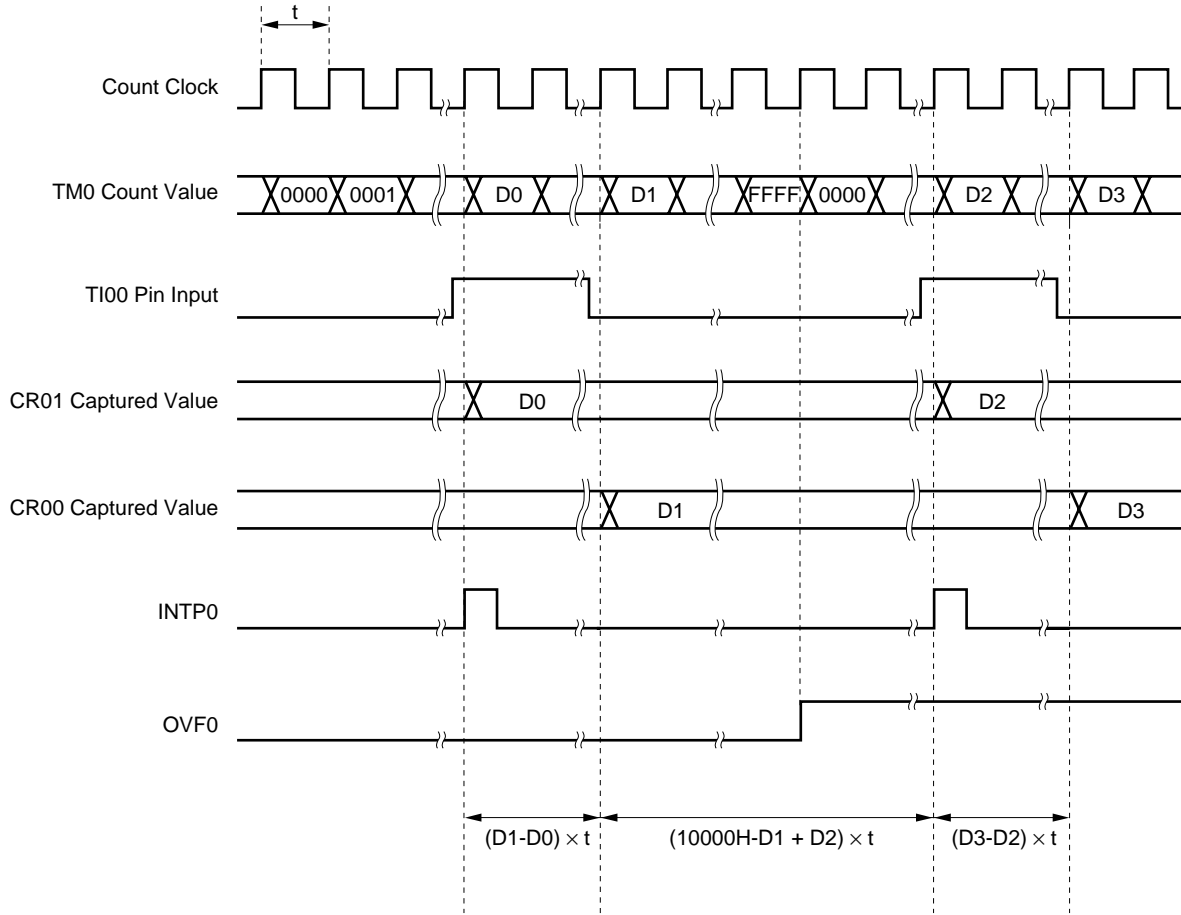
Caution If the valid edge of TI00/P00 is specified to be both rising and falling edge, capture/compare register 00 (CR00) cannot perform the capture operation.

Figure 8-22. Control Register Settings for Pulse Width Measurement with Free-Running Counter and Two Capture Registers



Remark 0/1: Setting 0 or 1 allows another function to be used simultaneously with pulse width measurement. See the description of the respective control registers for details.

Figure 8-23. Timing of Pulse Width Measurement Operation by Free-Running Counter and Two Capture Registers (with Rising Edge Specified)



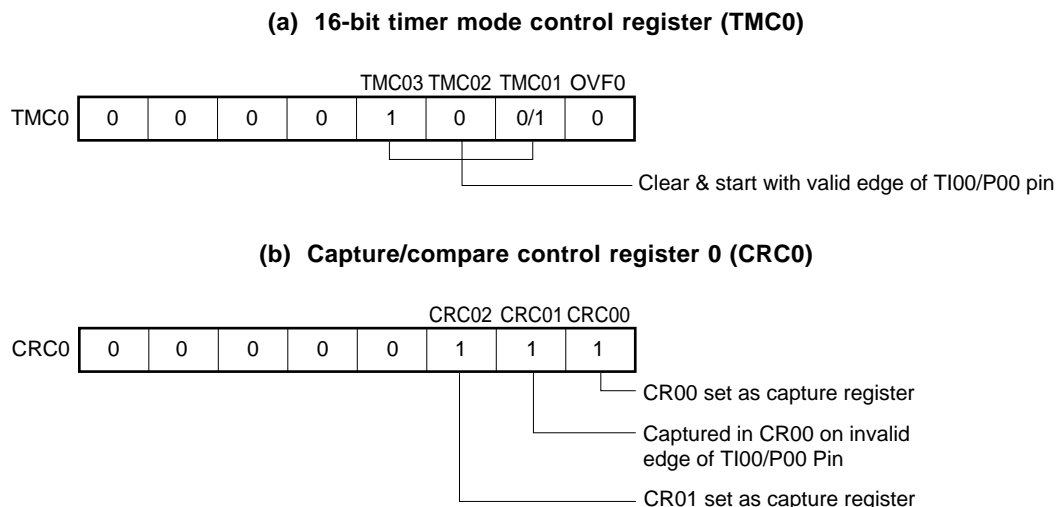
(4) Pulse width measurement by means of restart

When input of a valid edge to the TI00/P00 pin is detected, the count value of the 16-bit timer register (TM0) is taken into 16-bit capture/compare register 01 (CR01), and then the pulse width of the signal input to the TI00/P00 pin is measured by clearing TM0 and restarting the count (see register settings in Figure 8-24). The edge specification can be selected from two types, rising and falling edges by external interrupt mode register 0 (INTM0) bits 2 and 3 (ES10 and ES11).

In a valid edge detection, the sampling is performed by a cycle selected by the sampling clock selection register (SCS), and a capture operation is only performed when a valid level is detected twice, thus eliminating noise with a short pulse width.

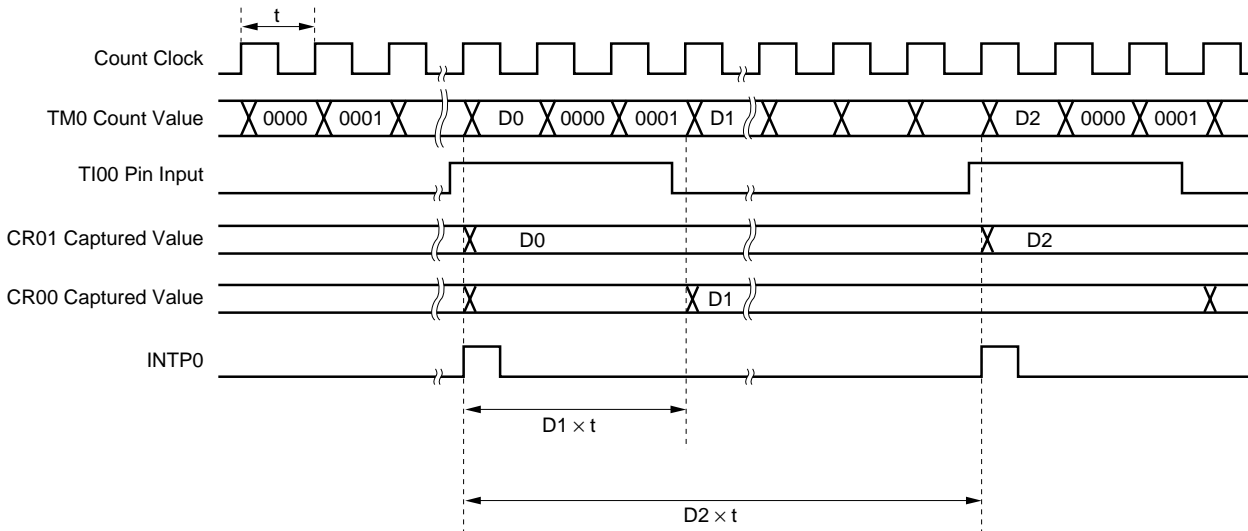
Caution If the valid edge of TI00/P00 is specified to be both rising and falling edge, the 16-bit capture/compare register 00 (CR00) cannot perform the capture operation.

Figure 8-24. Control Register Settings for Pulse Width Measurement by Means of Restart



Remark 0/1: Setting 0 or 1 allows another function to be used simultaneously with pulse width measurement. See the description of the respective control registers for details.

Figure 8-25. Timing of Pulse Width Measurement Operation by Means of Restart (with Rising Edge Specified)



8.5.5 External event counter operation

The external event counter counts the number of external clock pulses to be input to the TI00/P00 pin with the 16-bit timer register (TM0).

TM0 is incremented each time the valid edge specified with the external interrupt mode register 0 (INTM0) is input.

When the TM0 counted value matches the 16-bit capture/compare register 00 (CR00) value, TM0 is cleared to 0 and the interrupt request signal (INTTM00) is generated.

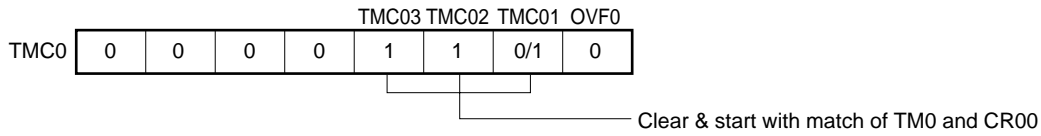
Set the value other than 0000H to CR00 (1-pulse count operation cannot be performed).

The rising edge, the falling edge or both edges can be selected with bits 2 and 3 (ES10 and ES11) of INTM0.

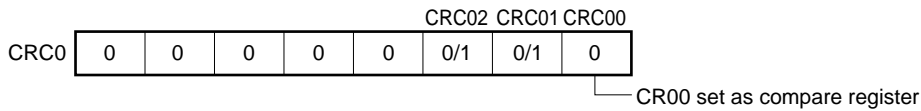
Because operation is carried out only after the valid edge is detected twice by sampling at the interval selected with the sampling clock select register (SCS), noise with short pulse widths can be removed.

Figure 8-26. Control Register Settings in External Event Counter Mode

(a) 16-bit timer mode control register (TMC0)



(b) Capture/compare control register 0 (CRC0)



Remark 0/1: Setting 0 or 1 allows another function to be used simultaneously with the external event counter. See the description of the respective control registers for details.

Figure 8-27. External Event Counter Configuration Diagram

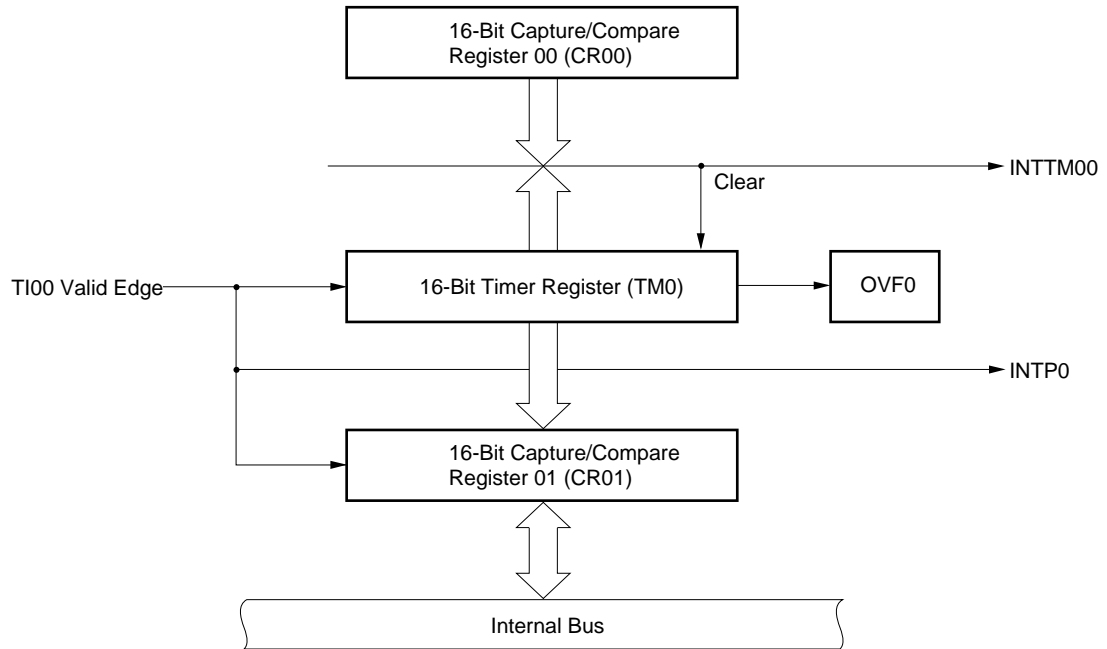
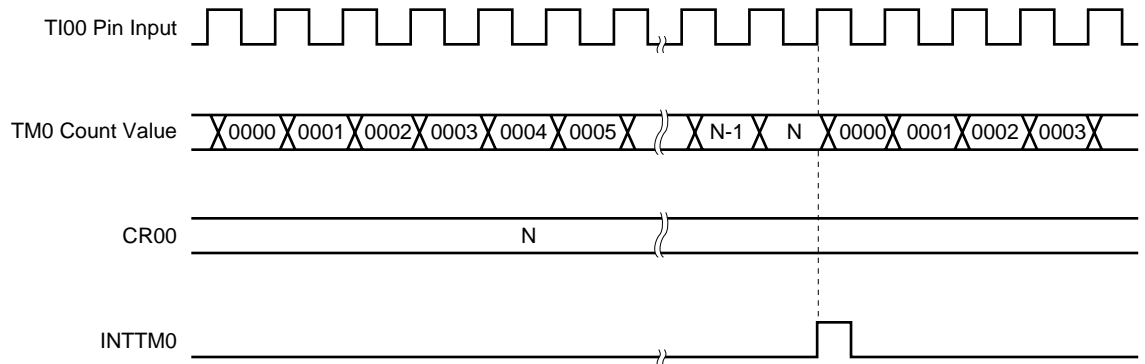


Figure 8-28. External Event Counter Operation Timings (with Rising Edge Specified)



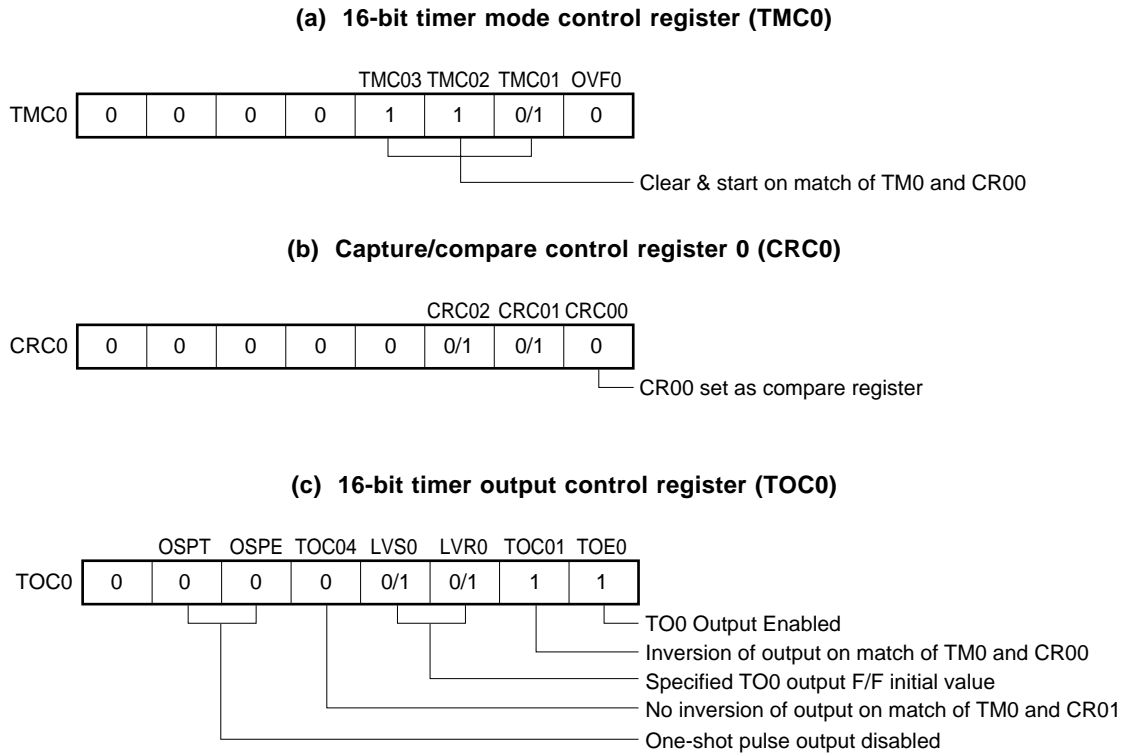
Caution When reading the external event counter count value, TM0 should be read.

8.5.6 Square-wave output operation

Operates as square wave output with any selected frequency at intervals of the count value preset to the 16-bit capture/compare register 00 (CR00).

The TO0/P30 pin output status is reversed at intervals of the count value preset to CR00 by setting bit 0 (TOE0) and bit 1 (TOC01) of the 16-bit timer output control register (TOC0) to 1. This enables a square wave with any selected frequency to be output.

Figure 8-29. Control Register Settings in Square-Wave Output Mode



Remark 0/1: Setting 0 or 1 allows another function to be used simultaneously with square-wave output. See the description of the respective control registers for details.

Figure 8-30. Square-Wave Output Operation Timing

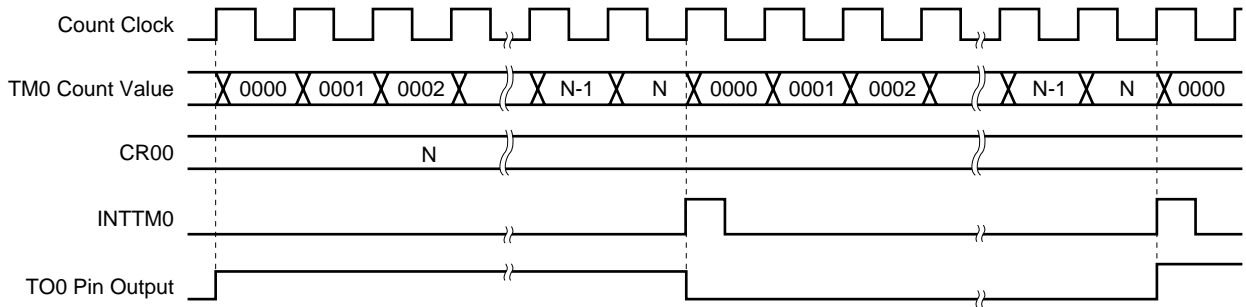


Table 8-7. 16-Bit Timer/Event Count Square-Wave Output Ranges

Minimum Pulse Width		Maximum Pulse Width		Resolution	
MCS = 1	MCS = 0	MCS = 1	MCS = 0	MCS = 1	MCS = 0
2 × T _{I00} input cycle		2 ¹⁶ × T _{I00} input cycle		T _{I00} input edge cycle	
—	2 × 1/f _x (400 ns)	—	2 ¹⁶ × 1/f _x (13.1 ms)	—	1/f _x (200 ns)
2 × 1/f _x (400 ns)	2 ² × 1/f _x (800 ns)	2 ¹⁶ × 1/f _x (13.1 ms)	2 ¹⁷ × 1/f _x (26.2 ms)	1/f _x (200 ns)	2 × 1/f _x (400 ns)
2 ² × 1/f _x (800 ns)	2 ³ × 1/f _x (1.6 μs)	2 ¹⁷ × 1/f _x (26.2 ms)	2 ¹⁸ × 1/f _x (52.4 ms)	2 × 1/f _x (400 ns)	2 ² × 1/f _x (800 ns)
2 ³ × 1/f _x (1.6 μs)	2 ⁴ × 1/f _x (3.2 μs)	2 ¹⁸ × 1/f _x (52.4 ms)	2 ¹⁹ × 1/f _x (104.9 ms)	2 ² × 1/f _x (800 ns)	2 ³ × 1/f _x (1.6 μs)
2 × watch timer output cycle		2 ¹⁶ × watch timer output cycle		Watch timer output edge cycle	

- Remarks**
1. f_x : Main system clock oscillation frequency
 2. MCS : Oscillation mode selection register (OSMS) bit 0
 3. Values in parentheses when operated at f_x = 5.0 MHz

8.5.7 One-shot pulse output operation

It is possible to output one-shot pulses synchronized with a software trigger or an external trigger (TI00/P00 pin input).

(1) One-shot pulse output using software trigger

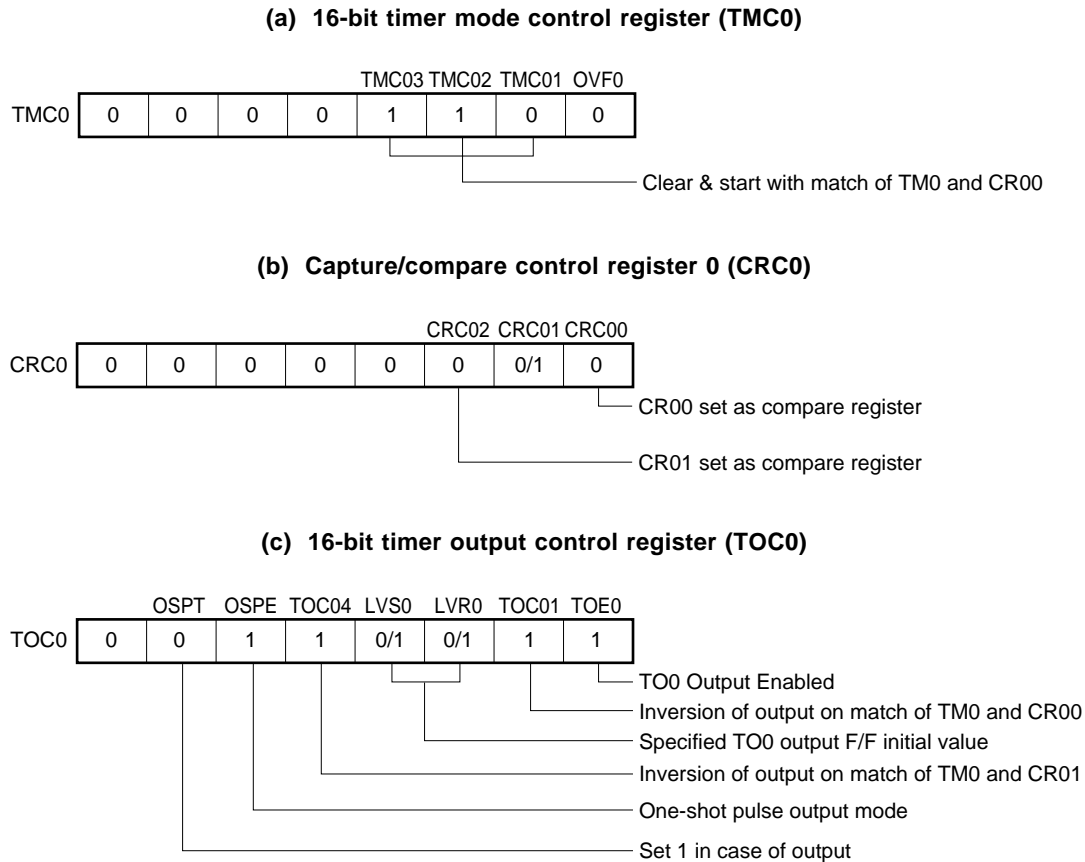
If the 16-bit timer mode control register (TMC0), capture/compare control register 0 (CRC0), and the 16-bit timer output control register (TOC0) are set as shown in Figure 8-31, and 1 is set in bit 6 (OSPT) of TOC0 by software, a one-shot pulse is output from the TO0/P30 pin.

By setting 1 in OSPT, the 16-bit timer/event counter is cleared and started, and output is activated by the count value set beforehand in 16-bit capture/compare register 01 (CR01). Thereafter, output is inactivated by the count value set beforehand in 16-bit capture/compare register 00 (CR00).

TM0 continues to operate after one-shot pulse is output. To stop TM0, 00H must be set to TMC0.

Caution When outputting one-shot pulse, do not set 1 in OSPT. When outputting one-shot pulse again, set OSPT to 1 after the INTTM00, or interrupt match signal with CR00, is generated.

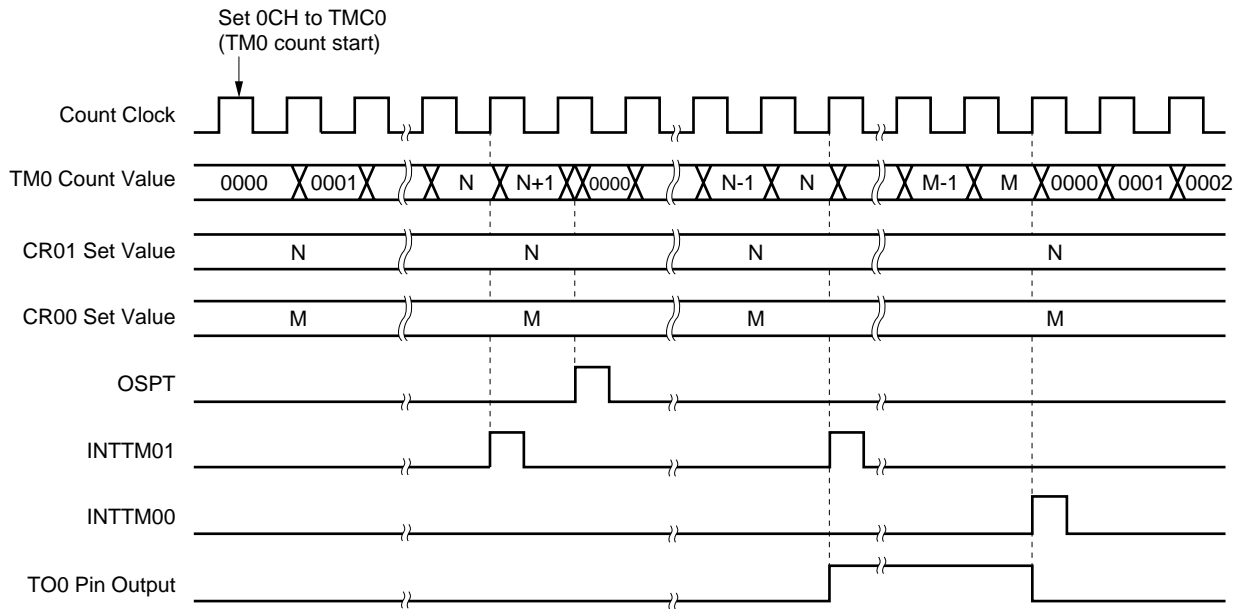
Figure 8-31. Control Register Settings for One-Shot Pulse Output Operation Using Software Trigger



Remark 0/1: Setting 0 or 1 allows another function to be used simultaneously with one-shot pulse output. See the description of the respective control registers for details.

Caution Values in the following range should be set in CR00 and CR01.
 $0000H \leq CR01 < CR00 \leq FFFFH$

Figure 8-32. Timing of One-Shot Pulse Output Operation Using Software Trigger



Caution The 16-bit timer register starts operation at the moment a value other than 0, 0, 0 (operation stop mode) is set to TMC01 to TMC03, respectively.

(2) One-shot pulse output using external trigger

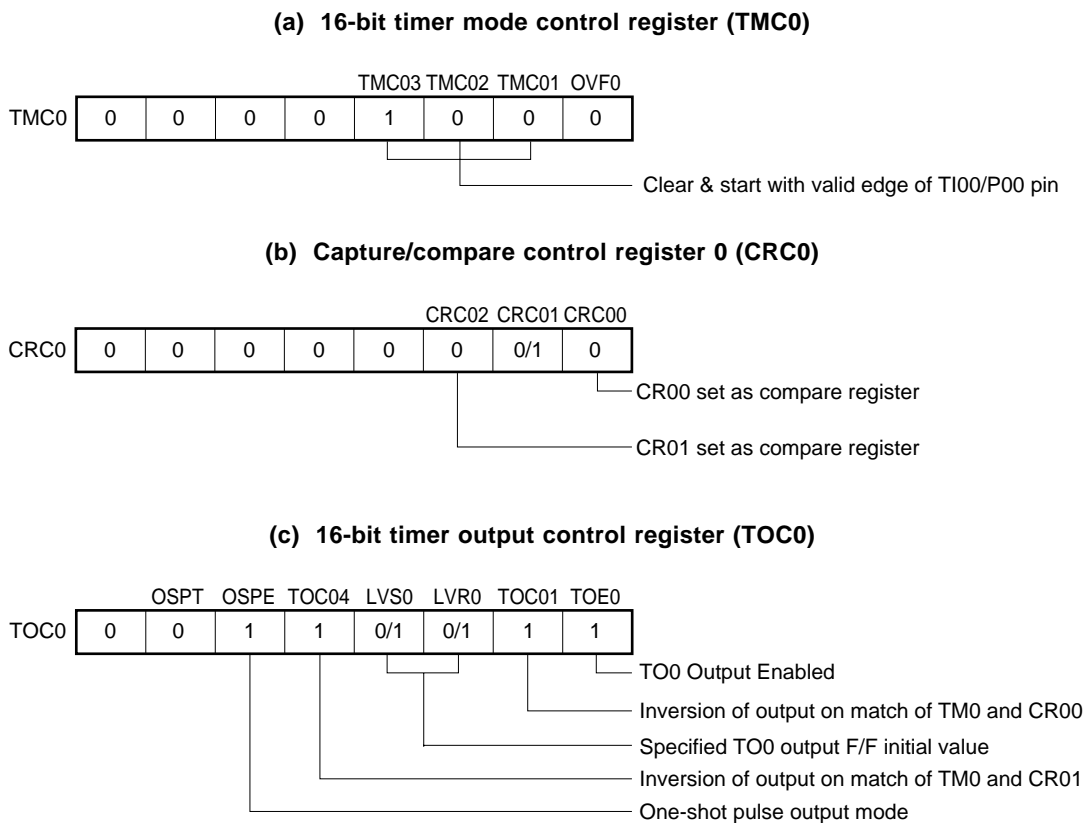
If the 16-bit timer mode control register (TMC0), capture/compare control register 0 (CRC0), and the 16-bit timer output control register (TOC0) are set as shown in Figure 8-33, a one-shot pulse is output from the TO0/P30 pin with a TI00/P00 valid edge as an external trigger.

Any of three edge specifications can be selected—rising, falling, or both edges — as the valid edges for the TI00/P00 pin by means of bits 2 and 3 (ES10 and ES11) of external interrupt mode register 0 (INTM0).

When a valid edge is input to the TI00/P00 pin, the 16-bit timer/event counter is cleared and started, and output is activated by the count values set beforehand in 16-bit capture/compare register 01 (CR01). Thereafter, output is inactivated by the count value set beforehand in 16-bit capture/compare register 00 (CR00).

Caution When outputting one-shot pulses, external trigger is ignored if generated again.

Figure 8-33. Control Register Settings for One-Shot Pulse Output Operation Using External Trigger

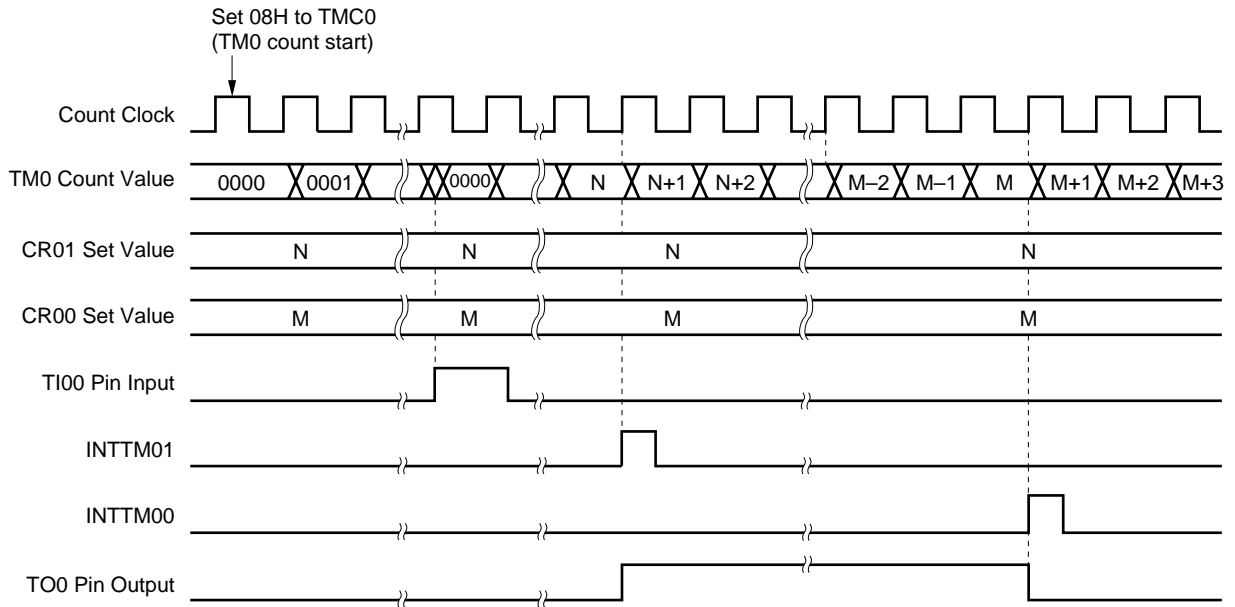


Remark 0/1: Setting 0 or 1 allows another function to be used simultaneously with one-shot pulse output. See the description of the respective control registers for details.

Caution Values in the following range should be set in CR00 and CR01.

$$0000H \leq CR01 < CR00 \leq FFFFH$$

Figure 8-34. Timing of One-Shot Pulse Output Operation Using External Trigger (With Rising Edge Specified)



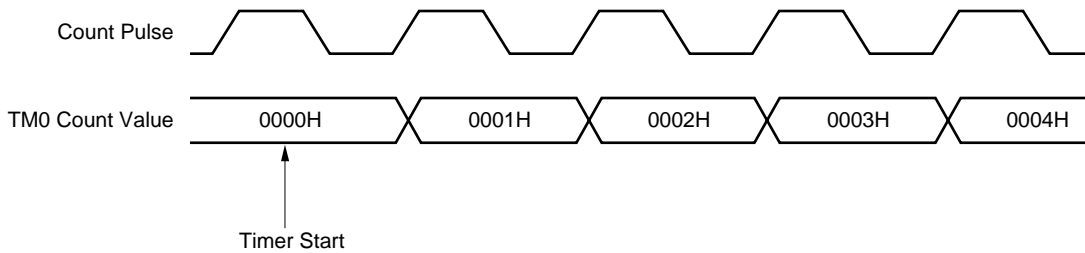
Caution The 16-bit timer register starts operation at the moment a value other than 0, 0, 0 (operation stop mode) is set to TMC01 to TMC03, respectively.

8.6 16-Bit Timer/Event Counter Operating Precautions

(1) Timer start errors

An error with a maximum of one clock may occur concerning the time required for a match signal to be generated after timer start. This is because the 16-bit timer register (TM0) starts asynchronously with the count pulse.

Figure 8-35. 16-Bit Timer Register Start Timing



(2) 16-bit compare register setting

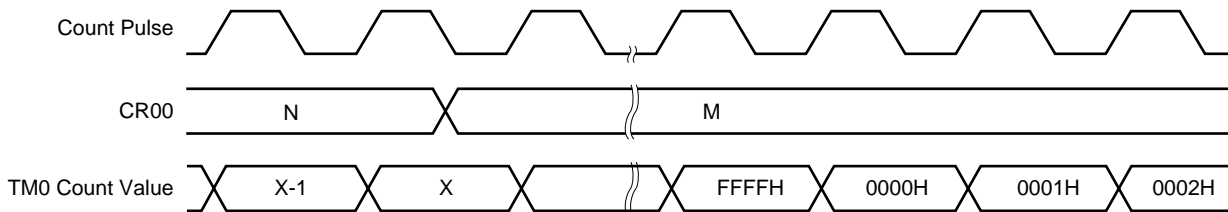
Set a value other than 0000H to the 16-bit capture/compare register 00 (CR00).

Thus, when using the 16-bit capture/compare register as event counter, one-pulse count operation cannot be carried out.

(3) Operation after compare register change during timer count operation

If the value after the 16-bit capture/compare register (CR00) is changed is smaller than that of the 16-bit timer register (TM0), TM0 continues counting, overflows and then restarts counting from 0. Thus, if the value (M) after CR00 change is smaller than that (N) before change, it is necessary to restart the timer after changing CR00.

Figure 8-36. Timings After Change of Compare Register During Timer Count Operation

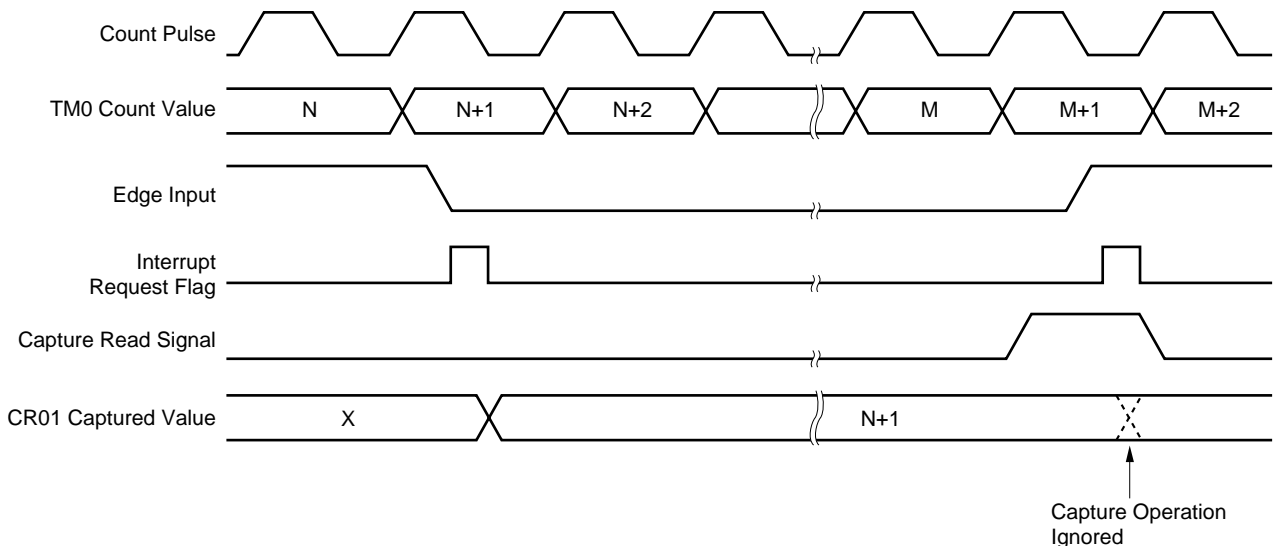


Remark $N > X > M$

(4) Capture register data retention timings

If the valid edge of the TI00/P00 pin is input during 16-bit capture/compare register 01 (CR01) read, CR01 holds data without carrying out capture operation. However, the interrupt request flag (PIF0) is set upon detection of the valid edge.

Figure 8-37. Capture Register Data Retention Timing



(5) Valid edge setting

Set the valid edge of the TI00/P00/INTP0 pin after setting bits 1 to 3 (TMC01 to TMC03) of the 16-bit timer mode control register (TMC0) to 0, 0 and 0, respectively, and then stopping timer operation. Valid edge is set with bits 2 and 3 (ES10 and ES11) of the external interrupt mode register 0 (INTM0).

(6) Re-trigger of one-shot pulse

(a) One-shot pulse output using software

When outputting one-shot pulse, do not set 1 in OSPT. When outputting one-shot pulse again, set OSPT to 1 after the INTTM00, or interrupt match signal with CR00, is generated.

(b) One-shot pulse output using external trigger

When outputting one-shot pulses, external trigger is ignored if generated again.

(7) Operation of OVFO flag

OVFO flag is set to 1 in the following case.

The clear & start mode on match between TM0 and CR00 is selected.

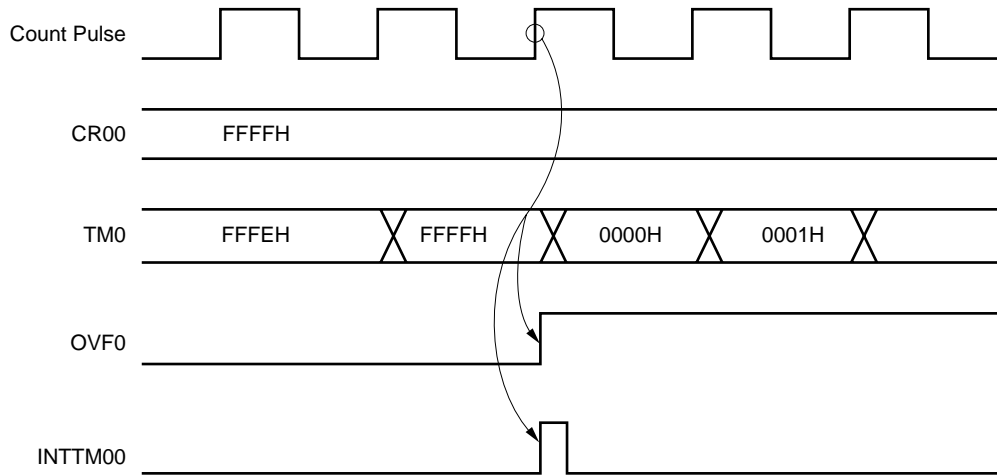


CR00 is set to FFFFH.



When TM0 is counted up from FFFFH to 0000H.

Figure 8-38. Operation Timing of OVFO Flag



CHAPTER 9 8-BIT TIMER/EVENT COUNTERS 1 AND 2

9.1 8-Bit Timer/Event Counters 1 and 2 Functions

For the 8-bit timer/event counters 1 and 2, two modes are available. One is a mode for two-channel 8-bit timer/event counters to be used separately (the 8-bit timer/event counter mode) and the other is a mode for the 8-bit timer/event counter to be used as 16-bit timer/event counter (the 16-bit timer/event counter mode).

9.1.1 8-bit timer/event counter mode

The 8-bit timer/event counters 1 and 2 (TM1 and TM2) have the following functions.

- Interval timer
- External event counter
- Square-wave output

(1) 8-bit interval timer

Interrupt requests are generated at the preset time intervals.

Table 9-1. 8-Bit Timer/Event Counters 1 and 2 Interval Times

Minimum Interval Time		Maximum Interval Time		Resolution	
MCS = 1	MCS = 0	MCS = 1	MCS = 0	MCS = 1	MCS = 0
$2 \times 1/f_x$ (400 ns)	$2^2 \times 1/f_x$ (800 ns)	$2^9 \times 1/f_x$ (102.4 μ s)	$2^{10} \times 1/f_x$ (204.8 μ s)	$2 \times 1/f_x$ (400 ns)	$2^2 \times 1/f_x$ (800 ns)
$2^2 \times 1/f_x$ (800 ns)	$2^3 \times 1/f_x$ (1.6 μ s)	$2^{10} \times 1/f_x$ (204.8 μ s)	$2^{11} \times 1/f_x$ (409.6 μ s)	$2^2 \times 1/f_x$ (800 ns)	$2^3 \times 1/f_x$ (1.6 μ s)
$2^3 \times 1/f_x$ (1.6 μ s)	$2^4 \times 1/f_x$ (3.2 μ s)	$2^{11} \times 1/f_x$ (409.6 μ s)	$2^{12} \times 1/f_x$ (819.2 μ s)	$2^3 \times 1/f_x$ (1.6 μ s)	$2^4 \times 1/f_x$ (3.2 μ s)
$2^4 \times 1/f_x$ (3.2 μ s)	$2^5 \times 1/f_x$ (6.4 μ s)	$2^{12} \times 1/f_x$ (819.2 μ s)	$2^{13} \times 1/f_x$ (1.64 ms)	$2^4 \times 1/f_x$ (3.2 μ s)	$2^5 \times 1/f_x$ (6.4 μ s)
$2^5 \times 1/f_x$ (6.4 μ s)	$2^6 \times 1/f_x$ (12.8 μ s)	$2^{13} \times 1/f_x$ (1.64 ms)	$2^{14} \times 1/f_x$ (3.28 ms)	$2^5 \times 1/f_x$ (6.4 μ s)	$2^6 \times 1/f_x$ (12.8 μ s)
$2^6 \times 1/f_x$ (12.8 μ s)	$2^7 \times 1/f_x$ (25.6 μ s)	$2^{14} \times 1/f_x$ (3.28 ms)	$2^{15} \times 1/f_x$ (6.55 ms)	$2^6 \times 1/f_x$ (12.8 μ s)	$2^7 \times 1/f_x$ (25.6 μ s)
$2^7 \times 1/f_x$ (25.6 μ s)	$2^8 \times 1/f_x$ (51.2 μ s)	$2^{15} \times 1/f_x$ (6.55 ms)	$2^{16} \times 1/f_x$ (13.1 ms)	$2^7 \times 1/f_x$ (25.6 μ s)	$2^8 \times 1/f_x$ (51.2 μ s)
$2^8 \times 1/f_x$ (51.2 μ s)	$2^9 \times 1/f_x$ (102.4 μ s)	$2^{16} \times 1/f_x$ (13.1 ms)	$2^{17} \times 1/f_x$ (26.2 ms)	$2^8 \times 1/f_x$ (51.2 μ s)	$2^9 \times 1/f_x$ (102.4 μ s)
$2^9 \times 1/f_x$ (102.4 μ s)	$2^{10} \times 1/f_x$ (204.8 μ s)	$2^{17} \times 1/f_x$ (26.2 ms)	$2^{18} \times 1/f_x$ (52.4 ms)	$2^9 \times 1/f_x$ (102.4 μ s)	$2^{10} \times 1/f_x$ (204.8 μ s)
$2^{11} \times 1/f_x$ (409.6 μ s)	$2^{12} \times 1/f_x$ (819.2 μ s)	$2^{19} \times 1/f_x$ (104.9 ms)	$2^{20} \times 1/f_x$ (209.7 ms)	$2^{11} \times 1/f_x$ (409.6 μ s)	$2^{12} \times 1/f_x$ (819.2 μ s)

- Remarks**
1. f_x : Main system clock oscillation frequency
 2. MCS : Oscillation mode selection register (OSMS) bit 0
 3. Values in parentheses when operated at $f_x = 5.0$ MHz.

(2) External event counter

The number of pulses of an externally input signal can be measured.

(3) Square-wave output

A square wave with any selected frequency can be output.

Table 9-2. 8-Bit Timer/Event Counters 1 and 2 Square-Wave Output Ranges

Minimum Pulse Width		Maximum Pulse Width		Resolution	
MCS = 1	MCS = 0	MCS = 1	MCS = 0	MCS = 1	MCS = 0
$2 \times 1/f_x$ (400 ns)	$2^2 \times 1/f_x$ (800 ns)	$2^9 \times 1/f_x$ (102.4 μ s)	$2^{10} \times 1/f_x$ (204.8 μ s)	$2 \times 1/f_x$ (400 ns)	$2^2 \times 1/f_x$ (800 ns)
$2^2 \times 1/f_x$ (800 ns)	$2^3 \times 1/f_x$ (1.6 μ s)	$2^{10} \times 1/f_x$ (204.8 μ s)	$2^{11} \times 1/f_x$ (409.6 μ s)	$2^2 \times 1/f_x$ (800 ns)	$2^3 \times 1/f_x$ (1.6 μ s)
$2^3 \times 1/f_x$ (1.6 μ s)	$2^4 \times 1/f_x$ (3.2 μ s)	$2^{11} \times 1/f_x$ (409.6 μ s)	$2^{12} \times 1/f_x$ (819.2 μ s)	$2^3 \times 1/f_x$ (1.6 μ s)	$2^4 \times 1/f_x$ (3.2 μ s)
$2^4 \times 1/f_x$ (3.2 μ s)	$2^5 \times 1/f_x$ (6.4 μ s)	$2^{12} \times 1/f_x$ (819.2 μ s)	$2^{13} \times 1/f_x$ (1.64 ms)	$2^4 \times 1/f_x$ (3.2 μ s)	$2^5 \times 1/f_x$ (6.4 μ s)
$2^5 \times 1/f_x$ (6.4 μ s)	$2^6 \times 1/f_x$ (12.8 μ s)	$2^{13} \times 1/f_x$ (1.64 ms)	$2^{14} \times 1/f_x$ (3.28 ms)	$2^5 \times 1/f_x$ (6.4 μ s)	$2^6 \times 1/f_x$ (12.8 μ s)
$2^6 \times 1/f_x$ (12.8 μ s)	$2^7 \times 1/f_x$ (25.6 μ s)	$2^{14} \times 1/f_x$ (3.28 ms)	$2^{15} \times 1/f_x$ (6.55 ms)	$2^6 \times 1/f_x$ (12.8 μ s)	$2^7 \times 1/f_x$ (25.6 μ s)
$2^7 \times 1/f_x$ (25.6 μ s)	$2^8 \times 1/f_x$ (51.2 μ s)	$2^{15} \times 1/f_x$ (6.55 ms)	$2^{16} \times 1/f_x$ (13.1 ms)	$2^7 \times 1/f_x$ (25.6 μ s)	$2^8 \times 1/f_x$ (51.2 μ s)
$2^8 \times 1/f_x$ (51.2 μ s)	$2^9 \times 1/f_x$ (102.4 μ s)	$2^{16} \times 1/f_x$ (13.1 ms)	$2^{17} \times 1/f_x$ (26.2 ms)	$2^8 \times 1/f_x$ (51.2 μ s)	$2^9 \times 1/f_x$ (102.4 μ s)
$2^9 \times 1/f_x$ (102.4 μ s)	$2^{10} \times 1/f_x$ (204.8 μ s)	$2^{17} \times 1/f_x$ (26.2 ms)	$2^{18} \times 1/f_x$ (52.4 ms)	$2^9 \times 1/f_x$ (102.4 μ s)	$2^{10} \times 1/f_x$ (204.8 μ s)
$2^{11} \times 1/f_x$ (409.6 μ s)	$2^{12} \times 1/f_x$ (819.2 μ s)	$2^{19} \times 1/f_x$ (104.9 ms)	$2^{20} \times 1/f_x$ (209.7 ms)	$2^{11} \times 1/f_x$ (409.6 μ s)	$2^{12} \times 1/f_x$ (819.2 μ s)

- Remarks**
1. f_x : Main system clock oscillation frequency
 2. MCS : Oscillation mode selection register (OSMS) bit 0
 3. Values in parentheses when operated at $f_x = 5.0$ MHz.

9.1.2 16-bit timer/event counter mode

(1) 16-bit interval timer

Interrupt requests can be generated at the preset time intervals.

Table 9-3. Interval Times when 8-Bit Timer/Event Counters 1 and 2 are Used as 16-Bit Timer/Event Counters

Minimum Interval Time		Maximum Interval Time		Resolution	
MCS = 1	MCS = 0	MCS = 1	MCS = 0	MCS = 1	MCS = 0
$2 \times 1/f_x$ (400 ns)	$2^2 \times 1/f_x$ (800 ns)	$2^{17} \times 1/f_x$ (26.2 ms)	$2^{18} \times 1/f_x$ (52.4 ms)	$2 \times 1/f_x$ (400 ns)	$2^2 \times 1/f_x$ (800 ns)
$2^2 \times 1/f_x$ (800 ns)	$2^3 \times 1/f_x$ (1.6 μ s)	$2^{18} \times 1/f_x$ (52.4 ms)	$2^{19} \times 1/f_x$ (104.9 ms)	$2^2 \times 1/f_x$ (800 ns)	$2^3 \times 1/f_x$ (1.6 μ s)
$2^3 \times 1/f_x$ (1.6 μ s)	$2^4 \times 1/f_x$ (3.2 μ s)	$2^{19} \times 1/f_x$ (104.9 ms)	$2^{20} \times 1/f_x$ (209.7 ms)	$2^3 \times 1/f_x$ (1.6 μ s)	$2^4 \times 1/f_x$ (3.2 μ s)
$2^4 \times 1/f_x$ (3.2 μ s)	$2^5 \times 1/f_x$ (6.4 μ s)	$2^{20} \times 1/f_x$ (209.7 ms)	$2^{21} \times 1/f_x$ (419.4 ms)	$2^4 \times 1/f_x$ (3.2 μ s)	$2^5 \times 1/f_x$ (6.4 μ s)
$2^5 \times 1/f_x$ (6.4 μ s)	$2^6 \times 1/f_x$ (12.8 μ s)	$2^{21} \times 1/f_x$ (419.4 ms)	$2^{22} \times 1/f_x$ (838.9 ms)	$2^5 \times 1/f_x$ (6.4 μ s)	$2^6 \times 1/f_x$ (12.8 μ s)
$2^6 \times 1/f_x$ (12.8 μ s)	$2^7 \times 1/f_x$ (25.6 μ s)	$2^{22} \times 1/f_x$ (838.9 ms)	$2^{23} \times 1/f_x$ (1.7 s)	$2^6 \times 1/f_x$ (12.8 μ s)	$2^7 \times 1/f_x$ (25.6 μ s)
$2^7 \times 1/f_x$ (25.6 μ s)	$2^8 \times 1/f_x$ (51.2 μ s)	$2^{23} \times 1/f_x$ (1.7 s)	$2^{24} \times 1/f_x$ (3.4 s)	$2^7 \times 1/f_x$ (25.6 μ s)	$2^8 \times 1/f_x$ (51.2 μ s)
$2^8 \times 1/f_x$ (51.2 μ s)	$2^9 \times 1/f_x$ (102.4 μ s)	$2^{24} \times 1/f_x$ (3.4 s)	$2^{25} \times 1/f_x$ (6.7 s)	$2^8 \times 1/f_x$ (51.2 μ s)	$2^9 \times 1/f_x$ (102.4 μ s)
$2^9 \times 1/f_x$ (102.4 μ s)	$2^{10} \times 1/f_x$ (204.8 μ s)	$2^{25} \times 1/f_x$ (6.7 s)	$2^{26} \times 1/f_x$ (13.4 s)	$2^9 \times 1/f_x$ (102.4 μ s)	$2^{10} \times 1/f_x$ (204.8 μ s)
$2^{11} \times 1/f_x$ (409.6 μ s)	$2^{12} \times 1/f_x$ (819.2 μ s)	$2^{27} \times 1/f_x$ (26.8 s)	$2^{28} \times 1/f_x$ (53.7 s)	$2^{11} \times 1/f_x$ (409.6 μ s)	$2^{12} \times 1/f_x$ (819.2 μ s)

- Remarks**
1. f_x : Main system clock oscillation frequency
 2. MCS : Oscillation mode selection register (OSMS) bit 0
 3. Values in parentheses when operated at $f_x = 5.0$ MHz.

(2) External event counter

The number of pulses of an externally input signal can be measured.

(3) Square-wave output

A square wave with any selected frequency can be output.

Table 9-4. Square-Wave Output Ranges when 8-Bit Timer/Event Counters 1 and 2 are Used as 16-Bit Timer/Event Counters

Minimum Pulse Width		Maximum Pulse Width		Resolution	
MCS = 1	MCS = 0	MCS = 1	MCS = 0	MCS = 1	MCS = 0
$2 \times 1/f_x$ (400 ns)	$2^2 \times 1/f_x$ (800 ns)	$2^{17} \times 1/f_x$ (26.2 ms)	$2^{18} \times 1/f_x$ (52.4 ms)	$2 \times 1/f_x$ (400 ns)	$2^2 \times 1/f_x$ (800 ns)
$2^2 \times 1/f_x$ (800 ns)	$2^3 \times 1/f_x$ (1.6 μ s)	$2^{18} \times 1/f_x$ (52.4 ms)	$2^{19} \times 1/f_x$ (104.9 ms)	$2^2 \times 1/f_x$ (800 ns)	$2^3 \times 1/f_x$ (1.6 μ s)
$2^3 \times 1/f_x$ (1.6 μ s)	$2^4 \times 1/f_x$ (3.2 μ s)	$2^{19} \times 1/f_x$ (104.9 ms)	$2^{20} \times 1/f_x$ (209.7 ms)	$2^3 \times 1/f_x$ (1.6 μ s)	$2^4 \times 1/f_x$ (3.2 μ s)
$2^4 \times 1/f_x$ (3.2 μ s)	$2^5 \times 1/f_x$ (6.4 μ s)	$2^{20} \times 1/f_x$ (209.7 ms)	$2^{21} \times 1/f_x$ (419.4 ms)	$2^4 \times 1/f_x$ (3.2 μ s)	$2^5 \times 1/f_x$ (6.4 μ s)
$2^5 \times 1/f_x$ (6.4 μ s)	$2^6 \times 1/f_x$ (12.8 μ s)	$2^{21} \times 1/f_x$ (419.4 ms)	$2^{22} \times 1/f_x$ (838.9 ms)	$2^5 \times 1/f_x$ (6.4 μ s)	$2^6 \times 1/f_x$ (12.8 μ s)
$2^6 \times 1/f_x$ (12.8 μ s)	$2^7 \times 1/f_x$ (25.6 μ s)	$2^{22} \times 1/f_x$ (838.9 ms)	$2^{23} \times 1/f_x$ (1.7 s)	$2^6 \times 1/f_x$ (12.8 μ s)	$2^7 \times 1/f_x$ (25.6 μ s)
$2^7 \times 1/f_x$ (25.6 μ s)	$2^8 \times 1/f_x$ (51.2 μ s)	$2^{23} \times 1/f_x$ (1.7 s)	$2^{24} \times 1/f_x$ (3.4 s)	$2^7 \times 1/f_x$ (25.6 μ s)	$2^8 \times 1/f_x$ (51.2 μ s)
$2^8 \times 1/f_x$ (51.2 μ s)	$2^9 \times 1/f_x$ (102.4 μ s)	$2^{24} \times 1/f_x$ (3.4 s)	$2^{25} \times 1/f_x$ (6.7 s)	$2^8 \times 1/f_x$ (51.2 μ s)	$2^9 \times 1/f_x$ (102.4 μ s)
$2^9 \times 1/f_x$ (102.4 μ s)	$2^{10} \times 1/f_x$ (204.8 μ s)	$2^{25} \times 1/f_x$ (6.7 s)	$2^{26} \times 1/f_x$ (13.4 s)	$2^9 \times 1/f_x$ (102.4 μ s)	$2^{10} \times 1/f_x$ (204.8 μ s)
$2^{11} \times 1/f_x$ (409.6 μ s)	$2^{12} \times 1/f_x$ (819.2 μ s)	$2^{27} \times 1/f_x$ (26.8 s)	$2^{28} \times 1/f_x$ (53.7 s)	$2^{11} \times 1/f_x$ (409.6 μ s)	$2^{12} \times 1/f_x$ (819.2 μ s)

- Remarks**
1. f_x : Main system clock oscillation frequency
 2. MCS : Oscillation mode selection register (OSMS) bit 0
 3. Values in parentheses when operated at $f_x = 5.0$ MHz.

9.2 8-Bit Timer/Event Counters 1 and 2 Configurations

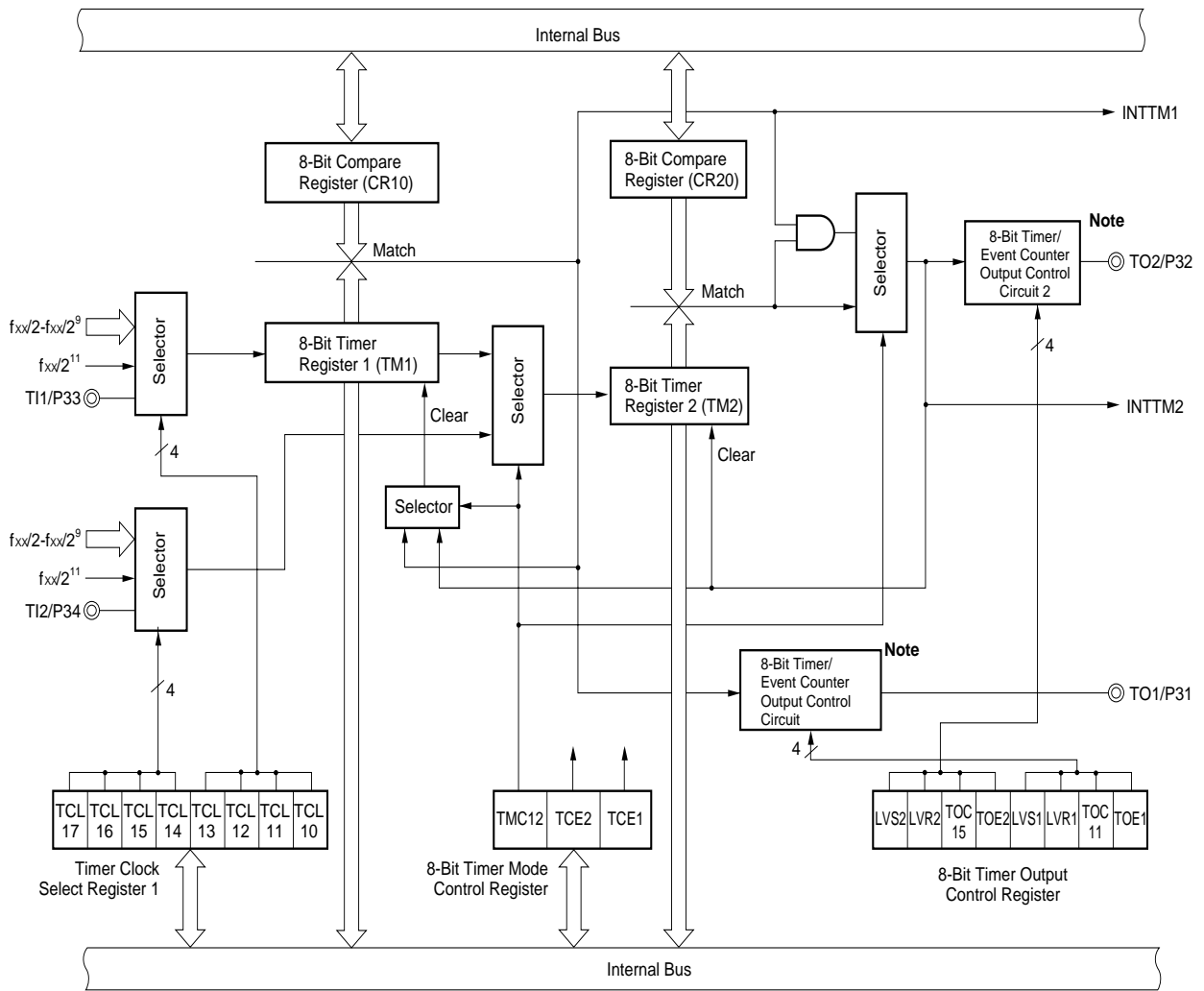
The 8-bit timer/event counters 1 and 2 consist of the following hardware.

Table 9-5. 8-Bit Timer/Event Counters 1 and 2 Configurations

Item	Configuration
Timer register	8 bits × 2 (TM1, TM2)
Register	Compare register: 8 bits × 2 (CR10, CR20)
Timer output	2 (TO1, TO2)
Control register	Timer clock select register 1 (TCL1) 8-bit timer mode control register 1 (TMC1) 8-bit timer output control register (TOC1) Port mode register 3 (PM3) ^{Note}

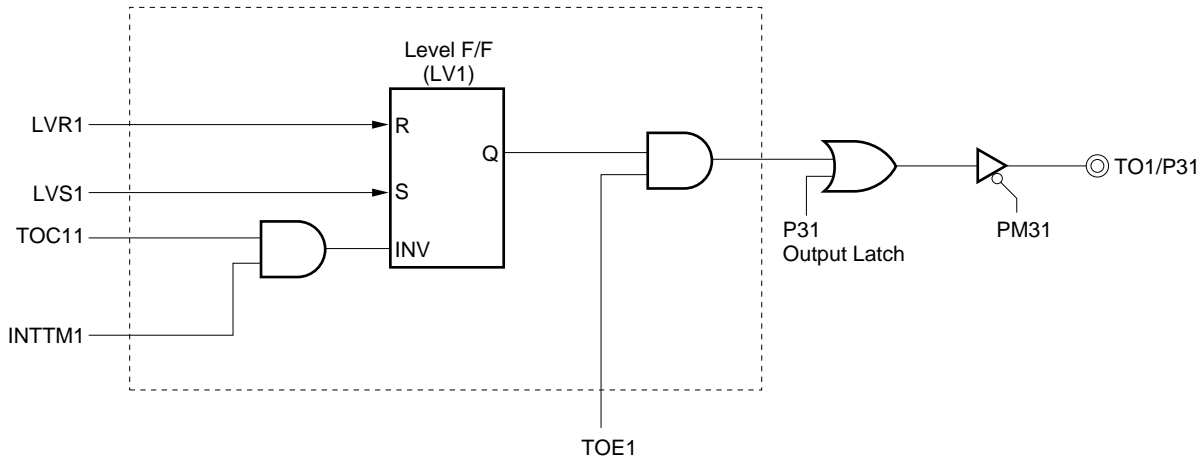
Note Refer to Figure 6-9. Block Diagram of P30 to P37.

Figure 9-1. 8-Bit Timer/Event Counters 1 and 2 Block Diagram



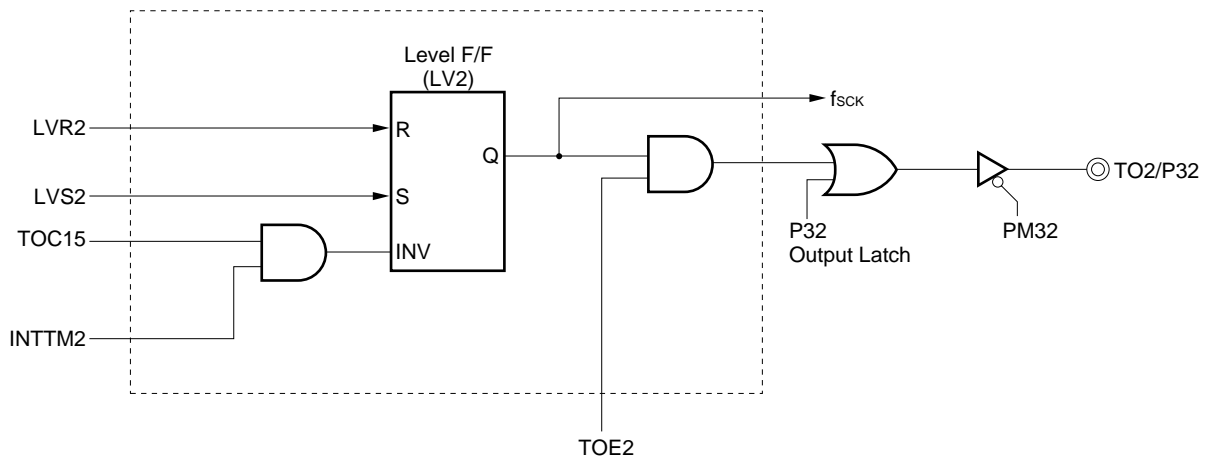
Note Refer to Figures 9-2 and 9-3 for details of 8-bit timer/event counters 1 and 2 output control circuits 1 and 2, respectively.

Figure 9-2. Block Diagram of 8-Bit Timer/Event Counter Output Control Circuit 1



Remark The section in the broken line is an output control circuit.

Figure 9-3. Block Diagram of 8-Bit Timer/Event Counter Output Control Circuit 2



Remarks 1. The section in the broken line is an output control circuit.
 2. fsc : Serial clock frequency

(1) Compare registers 10 and 20 (CR10, CR20)

These are 8-bit registers to compare the value set to CR10 to the 8-bit timer register 1 (TM1) count value, and the value set to CR20 to the 8-bit timer register 2 (TM2) count value, and, if they match, generate an interrupt request (INTTM1 and INTTM2, respectively).

This register can also be used as the register which holds the interval time when setting TM1 and TM2 to interval timer operation.

CR10 and CR20 are set with an 8-bit memory manipulation instruction. They cannot be set with a 16-bit memory manipulation instruction. When the compare register is used as 8-bit timer/event counter, the 00H to FFH values can be set. When the compare register is used as 16-bit timer/event counter, the 0000H to FFFFH values can be set.

$\overline{\text{RESET}}$ input makes CR10 and CR20 undefined.

Caution When using the compare register as 16-bit timer/event counter, be sure to set data after stopping timer operation.

(2) 8-bit timer registers 1, 2 (TM1, TM2)

These are 8-bit registers to count count pulses.

When TM1 and TM2 are used in the 8-bit timer \times 2-channel mode, they are read with an 8-bit memory manipulation instruction. When TM1 and TM2 are used as 16-bit timer \times 1-channel mode, 16-bit timer (TMS) is read with a 16-bit memory manipulation instruction.

$\overline{\text{RESET}}$ input sets TM1 and TM2 to 00H.

9.3 8-Bit Timer/Event Counters 1 and 2 Control Registers

The following four types of registers are used to control the 8-bit timer/event counter.

- Timer clock select register 1 (TCL1)
- 8-bit timer mode control register 1 (TMC1)
- 8-bit timer output control register (TOC1)
- Port mode register 3 (PM3)

(1) Timer clock select register 1 (TCL1)

This register sets count clocks of 8-bit timer registers 1 and 2.

TCL1 is set with an 8-bit memory manipulation instruction.

$\overline{\text{RESET}}$ input sets TCL1 to 00H.

Figure 9-4. Timer Clock Select Register 1 Format

Symbol	7	6	5	4	3	2	1	0	Address	After Reset	R/W
TCL1	TCL17	TCL16	TCL15	TCL14	TCL13	TCL12	TCL11	TCL10	FF41H	00H	R/W

8-Bit Timer Register 1 Count Clock Selection					
TCL13	TCL12	TCL11	TCL10	MCS = 1	MCS = 0
0	0	0	0	TI1 falling edge	
0	0	0	1	TI1 rising edge	
0	1	1	0	$f_{xx}/2$	$f_x/2$ (2.5 MHz) $f_x/2^2$ (1.25 MHz)
0	1	1	1	$f_{xx}/2^2$	$f_x/2^2$ (1.25 MHz) $f_x/2^3$ (625 kHz)
1	0	0	0	$f_{xx}/2^3$	$f_x/2^3$ (625 kHz) $f_x/2^4$ (313 kHz)
1	0	0	1	$f_{xx}/2^4$	$f_x/2^4$ (313 kHz) $f_x/2^5$ (156 kHz)
1	0	1	0	$f_{xx}/2^5$	$f_x/2^5$ (156 kHz) $f_x/2^6$ (78.1 kHz)
1	0	1	1	$f_{xx}/2^6$	$f_x/2^6$ (78.1 kHz) $f_x/2^7$ (39.1 kHz)
1	1	0	0	$f_{xx}/2^7$	$f_x/2^7$ (39.1 kHz) $f_x/2^8$ (19.5 kHz)
1	1	0	1	$f_{xx}/2^8$	$f_x/2^8$ (19.5 kHz) $f_x/2^9$ (9.8 kHz)
1	1	1	0	$f_{xx}/2^9$	$f_x/2^9$ (9.8 kHz) $f_x/2^{10}$ (4.9 kHz)
1	1	1	1	$f_{xx}/2^{11}$	$f_x/2^{11}$ (2.4 kHz) $f_x/2^{12}$ (1.2 kHz)
Other than above				Setting prohibited	

8-Bit Timer Register 2 Count Clock Selection					
TCL17	TCL16	TCL15	TCL14	MCS = 1	MCS = 0
0	0	0	0	TI2 falling edge	
0	0	0	1	TI2 rising edge	
0	1	1	0	$f_{xx}/2$	$f_x/2$ (2.5 MHz) $f_x/2^2$ (1.25 MHz)
0	1	1	1	$f_{xx}/2^2$	$f_x/2^2$ (1.25 MHz) $f_x/2^3$ (625 kHz)
1	0	0	0	$f_{xx}/2^3$	$f_x/2^3$ (625 kHz) $f_x/2^4$ (313 kHz)
1	0	0	1	$f_{xx}/2^4$	$f_x/2^4$ (313 kHz) $f_x/2^5$ (156 kHz)
1	0	1	0	$f_{xx}/2^5$	$f_x/2^5$ (156 kHz) $f_x/2^6$ (78.1 kHz)
1	0	1	1	$f_{xx}/2^6$	$f_x/2^6$ (78.1 kHz) $f_x/2^7$ (39.1 kHz)
1	1	0	0	$f_{xx}/2^7$	$f_x/2^7$ (39.1 kHz) $f_x/2^8$ (19.5 kHz)
1	1	0	1	$f_{xx}/2^8$	$f_x/2^8$ (19.5 kHz) $f_x/2^9$ (9.8 kHz)
1	1	1	0	$f_{xx}/2^9$	$f_x/2^9$ (9.8 kHz) $f_x/2^{10}$ (4.9 kHz)
1	1	1	1	$f_{xx}/2^{11}$	$f_x/2^{11}$ (2.4 kHz) $f_x/2^{12}$ (1.2 kHz)
Other than above				Setting prohibited	

Caution When rewriting TCL1 to other data, stop the timer operation beforehand.

- Remarks**
1. f_{xx} : Main system clock frequency (f_x or $f_x/2$)
 2. f_x : Main system clock oscillation frequency
 3. TI1 : 8-bit timer register 1 input pin
 4. TI2 : 8-bit timer register 2 input pin
 5. MCS : Oscillation mode selection register (OSMS) bit 0
 6. Figures in parentheses apply to operation with $f_x = 5.0$ MHz

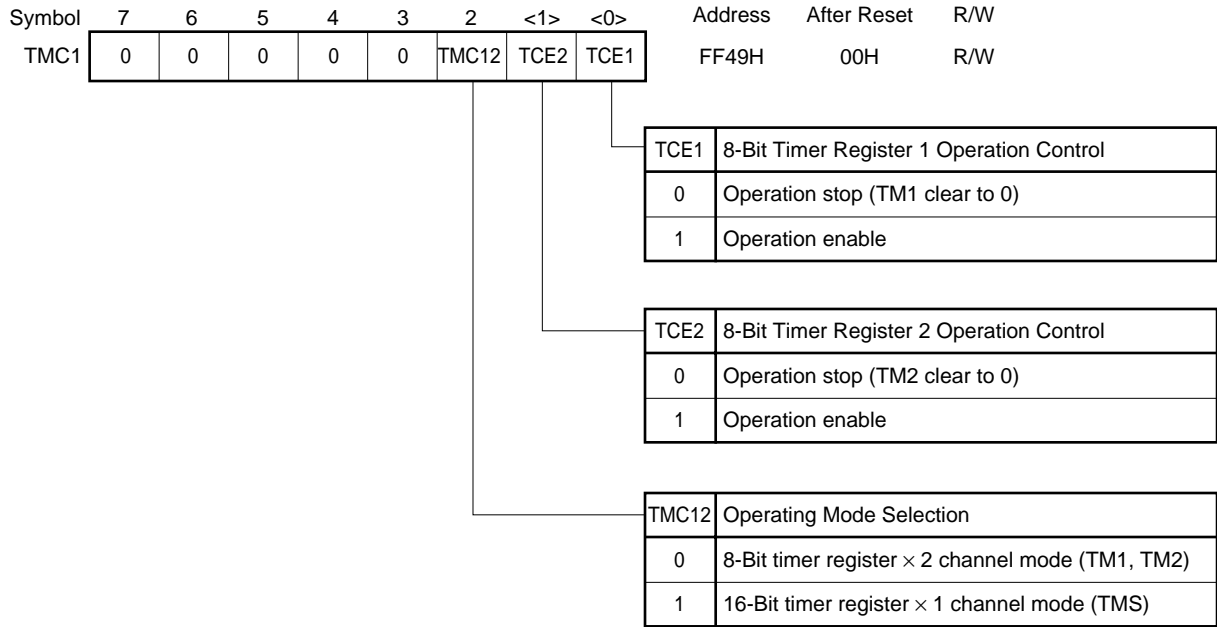
(2) 8-bit timer mode control register (TMC1)

This register enables/stops operation of 8-bit timer registers 1 and 2 and sets the operating mode of 8-bit timer register 1 and 2.

TMC1 is set with a 1-bit or 8-bit memory manipulation instruction.

RESET input sets TMC1 to 00H.

Figure 9-5. 8-Bit Timer Mode Control Register 1 Format



Cautions 1. Switch the operating mode after stopping timer operation.

2. When used as 16-bit timer register, TCE1 should be used for control enable/stop.

(3) 8-bit timer output control register (TOC1)

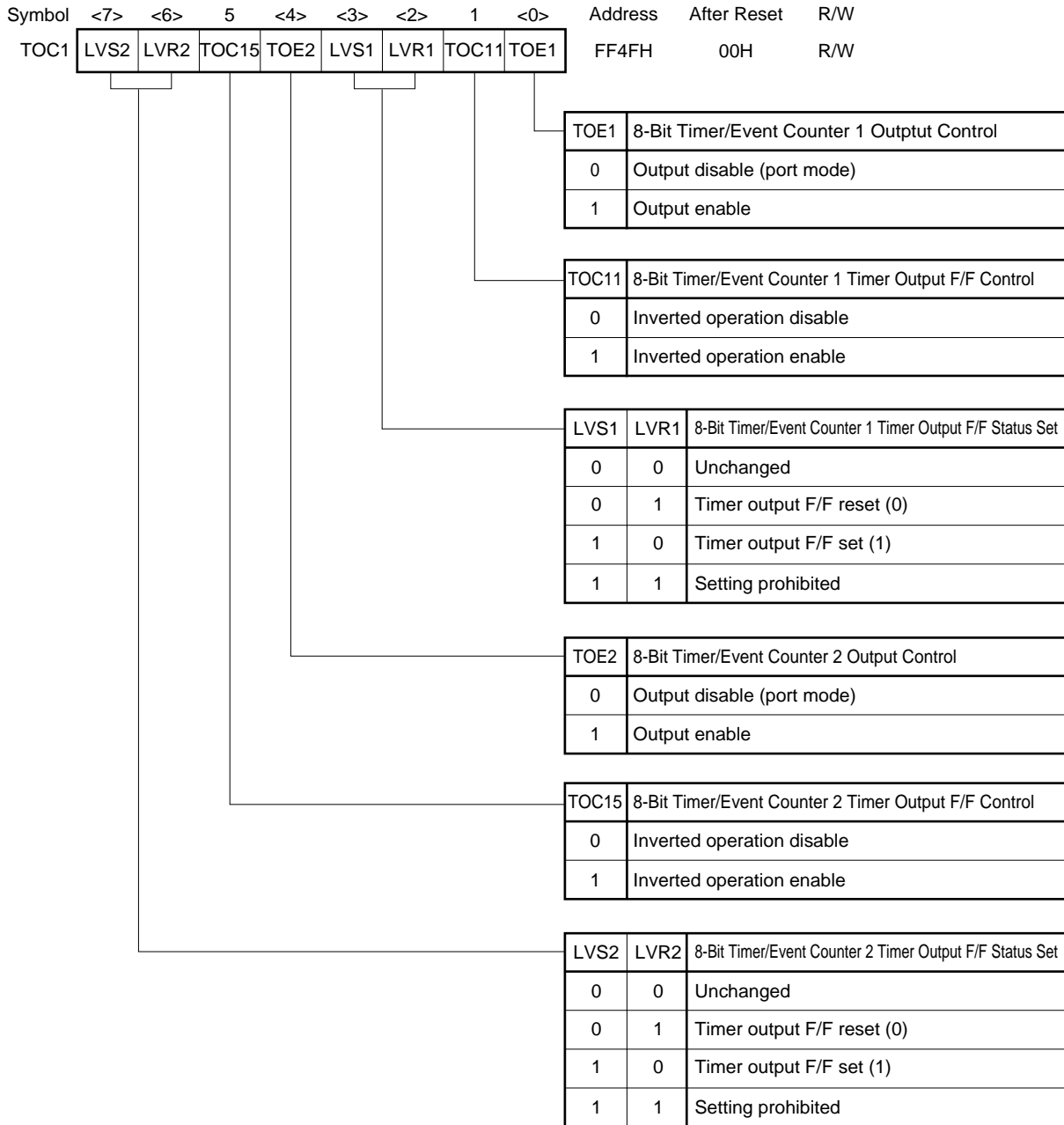
This register controls operation of 8-bit timer/event counter output control circuits 1 and 2.

It sets/resets the R-S flip-flops (LV1 and LV2) and enables/disables inversion and 8-bit timer output of 8-bit timer registers 1 and 2.

TOC1 is set with a 1-bit or 8-bit memory manipulation instruction.

$\overline{\text{RESET}}$ input sets TOC1 to 00H.

Figure 9-6. 8-Bit Timer Output Control Register Format



Cautions 1. Be sure to set TOC1 after stopping timer operation.

2. After data setting, 0 can be read from LVS1, LVS2, LVR1 and LVR2.

(4) Port mode register 3 (PM3)

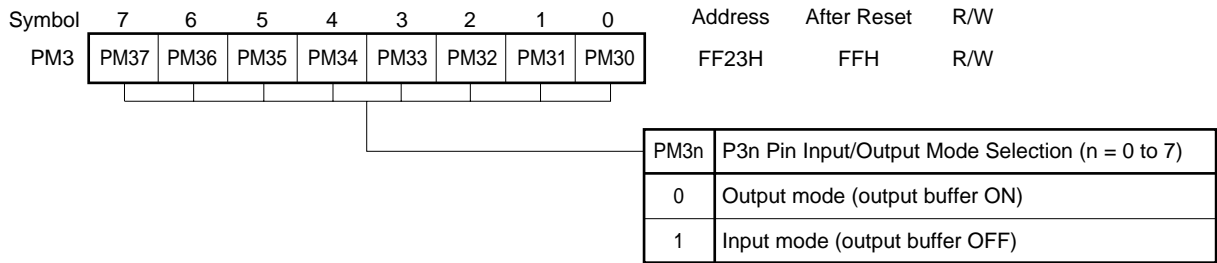
This register sets port 3 input/output in 1-bit units.

When using the P31/TO1 and P32/TO2 pins for timer output, set PM31, PM32, and output latches of P31 and P32 to 0.

PM3 is set with a 1-bit or 8-bit memory manipulation instruction.

$\overline{\text{RESET}}$ input sets PM3 to FFH.

Figure 9-7. Port Mode Register 3 Format



9.4 8-Bit Timer/Event Counters 1 and 2 Operations

9.4.1 8-bit timer/event counter mode

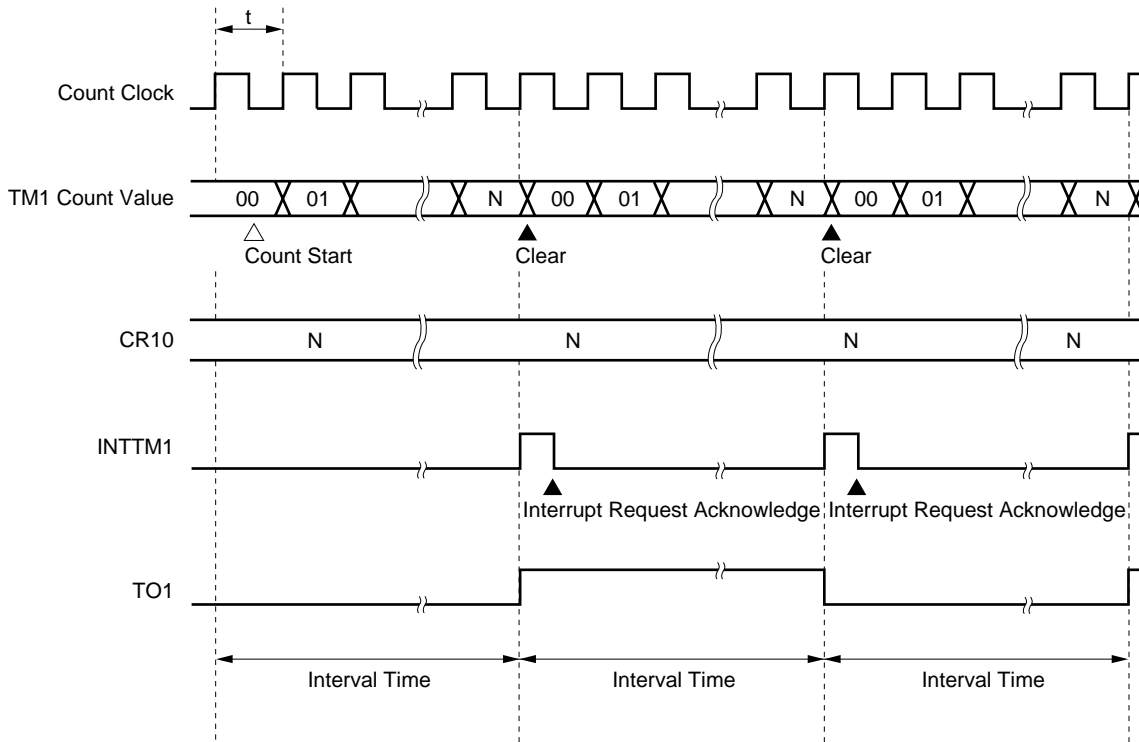
(1) Interval timer operations

The 8-bit timer/event counters 1 and 2 operate as interval timers which generate interrupt requests repeatedly at intervals of the count value preset to 8-bit compare registers 10 and 20 (CR10 and CR20).

When the count values of the 8-bit timer registers 1 and 2 (TM1 and TM2) match the values set to CR10 and CR20, counting continues with the TM1 and TM2 values cleared to 0 and the interrupt request signals (INTTM1 and INTTM2) are generated.

Count clock of TM1 can be selected with bits 0 to 3 (TCL10 to TCL13) of the timer clock select register 1 (TCL1). Count clock of TM2 can be selected with bits 4 to 7 (TCL14 to TCL17) of the timer clock select register 1 (TCL1). For the operation when the value of the compare register is changed during the timer count operation, refer to **9.5 8-Bit Timer/Event Counter Precautions (3)**.

Figure 9-8. Interval Timer Operation Timings



Remark Interval time = $(N + 1) \times t$: N = 00H to FFH

Table 9-6. 8-Bit Timer/Event Counter 1 Interval Time

TCL13	TCL12	TCL11	TCL10	Minimum Interval Time		Maximum Interval Time		Resolution	
				MCS = 1	MCS = 0	MCS = 1	MCS = 0	MCS = 1	MCS = 0
0	0	0	0	T11 input cycle		$2^8 \times$ T11 input cycle		T11 input edge cycle	
0	0	0	1	T11 input cycle		$2^8 \times$ T11 input cycle		T11 input edge cycle	
0	1	1	0	$2 \times 1/f_x$ (400 ns)	$2^2 \times 1/f_x$ (800 ns)	$2^9 \times 1/f_x$ (102.4 μ s)	$2^{10} \times 1/f_x$ (204.8 μ s)	$2 \times 1/f_x$ (400 ns)	$2^2 \times 1/f_x$ (800 ns)
0	1	1	1	$2^2 \times 1/f_x$ (800 ns)	$2^3 \times 1/f_x$ (1.6 μ s)	$2^{10} \times 1/f_x$ (204.8 μ s)	$2^{11} \times 1/f_x$ (409.6 μ s)	$2^2 \times 1/f_x$ (800 ns)	$2^3 \times 1/f_x$ (1.6 μ s)
1	0	0	0	$2^3 \times 1/f_x$ (1.6 μ s)	$2^4 \times 1/f_x$ (3.2 μ s)	$2^{11} \times 1/f_x$ (409.6 μ s)	$2^{12} \times 1/f_x$ (819.2 μ s)	$2^3 \times 1/f_x$ (1.6 μ s)	$2^4 \times 1/f_x$ (3.2 μ s)
1	0	0	1	$2^4 \times 1/f_x$ (3.2 μ s)	$2^5 \times 1/f_x$ (6.4 μ s)	$2^{12} \times 1/f_x$ (819.2 μ s)	$2^{13} \times 1/f_x$ (1.64 ms)	$2^4 \times 1/f_x$ (3.2 μ s)	$2^5 \times 1/f_x$ (6.4 μ s)
1	0	1	0	$2^5 \times 1/f_x$ (6.4 μ s)	$2^6 \times 1/f_x$ (12.8 μ s)	$2^{13} \times 1/f_x$ (1.64 ms)	$2^{14} \times 1/f_x$ (3.28 ms)	$2^5 \times 1/f_x$ (6.4 μ s)	$2^6 \times 1/f_x$ (12.8 μ s)
1	0	1	1	$2^6 \times 1/f_x$ (12.8 μ s)	$2^7 \times 1/f_x$ (25.6 μ s)	$2^{14} \times 1/f_x$ (3.28 ms)	$2^{15} \times 1/f_x$ (6.55 ms)	$2^6 \times 1/f_x$ (12.8 μ s)	$2^7 \times 1/f_x$ (25.6 μ s)
1	1	0	0	$2^7 \times 1/f_x$ (25.6 μ s)	$2^8 \times 1/f_x$ (51.2 μ s)	$2^{15} \times 1/f_x$ (6.55 ms)	$2^{16} \times 1/f_x$ (13.1 ms)	$2^7 \times 1/f_x$ (25.6 μ s)	$2^8 \times 1/f_x$ (51.2 μ s)
1	1	0	1	$2^8 \times 1/f_x$ (51.2 μ s)	$2^9 \times 1/f_x$ (102.4 μ s)	$2^{16} \times 1/f_x$ (13.1 ms)	$2^{17} \times 1/f_x$ (26.2 ms)	$2^8 \times 1/f_x$ (51.2 μ s)	$2^9 \times 1/f_x$ (102.4 μ s)
1	1	1	0	$2^9 \times 1/f_x$ (102.4 μ s)	$2^{10} \times 1/f_x$ (204.8 μ s)	$2^{17} \times 1/f_x$ (26.2 ms)	$2^{18} \times 1/f_x$ (52.4 ms)	$2^9 \times 1/f_x$ (102.4 μ s)	$2^{10} \times 1/f_x$ (204.8 μ s)
1	1	1	1	$2^{11} \times 1/f_x$ (409.6 μ s)	$2^{12} \times 1/f_x$ (819.2 μ s)	$2^{19} \times 1/f_x$ (104.9 ms)	$2^{20} \times 1/f_x$ (209.7 ms)	$2^{11} \times 1/f_x$ (409.6 μ s)	$2^{12} \times 1/f_x$ (819.2 μ s)
Other than above				Setting prohibited					

- Remarks**
1. f_x : Main system clock oscillation frequency
 2. MCS : Oscillation mode selection register (OSMS) bit 0
 3. TCL10 to TCL13 : Bits 0 to 3 of timer clock select register 1 (TCL1)
 4. Values in parentheses when operated at $f_x = 5.0$ MHz.

Table 9-7. 8-Bit Timer/Event Counter 2 Interval Time

TCL17	TCL16	TCL15	TCL14	Minimum Interval Time		Maximum Interval Time		Resolution	
				MCS = 1	MCS = 0	MCS = 1	MCS = 0	MCS = 1	MCS = 0
0	0	0	0	TI2 input cycle		$2^8 \times$ TI2 input cycle		TI2 input edge cycle	
0	0	0	1	TI2 input cycle		$2^8 \times$ TI2 input cycle		TI2 input edge cycle	
0	1	1	0	$2 \times 1/f_x$ (400 ns)	$2^2 \times 1/f_x$ (800 ns)	$2^9 \times 1/f_x$ (102.4 μ s)	$2^{10} \times 1/f_x$ (204.8 μ s)	$2 \times 1/f_x$ (400 ns)	$2^2 \times 1/f_x$ (800 ns)
0	1	1	1	$2^2 \times 1/f_x$ (800 ns)	$2^3 \times 1/f_x$ (1.6 μ s)	$2^{10} \times 1/f_x$ (204.8 μ s)	$2^{11} \times 1/f_x$ (409.6 μ s)	$2^2 \times 1/f_x$ (800 ns)	$2^3 \times 1/f_x$ (1.6 μ s)
1	0	0	0	$2^3 \times 1/f_x$ (1.6 μ s)	$2^4 \times 1/f_x$ (3.2 μ s)	$2^{11} \times 1/f_x$ (409.6 μ s)	$2^{12} \times 1/f_x$ (819.2 μ s)	$2^3 \times 1/f_x$ (1.6 μ s)	$2^4 \times 1/f_x$ (3.2 μ s)
1	0	0	1	$2^4 \times 1/f_x$ (3.2 μ s)	$2^5 \times 1/f_x$ (6.4 μ s)	$2^{12} \times 1/f_x$ (819.2 μ s)	$2^{13} \times 1/f_x$ (1.64 ms)	$2^4 \times 1/f_x$ (3.2 μ s)	$2^5 \times 1/f_x$ (6.4 μ s)
1	0	1	0	$2^5 \times 1/f_x$ (6.4 μ s)	$2^6 \times 1/f_x$ (12.8 μ s)	$2^{13} \times 1/f_x$ (1.64 ms)	$2^{14} \times 1/f_x$ (3.28 ms)	$2^5 \times 1/f_x$ (6.4 μ s)	$2^6 \times 1/f_x$ (12.8 μ s)
1	0	1	1	$2^6 \times 1/f_x$ (12.8 μ s)	$2^7 \times 1/f_x$ (25.6 μ s)	$2^{14} \times 1/f_x$ (3.28 ms)	$2^{15} \times 1/f_x$ (6.55 ms)	$2^6 \times 1/f_x$ (12.8 μ s)	$2^7 \times 1/f_x$ (25.6 μ s)
1	1	0	0	$2^7 \times 1/f_x$ (25.6 μ s)	$2^8 \times 1/f_x$ (51.2 μ s)	$2^{15} \times 1/f_x$ (6.55 ms)	$2^{16} \times 1/f_x$ (13.1 ms)	$2^7 \times 1/f_x$ (25.6 μ s)	$2^8 \times 1/f_x$ (51.2 μ s)
1	1	0	1	$2^8 \times 1/f_x$ (51.2 μ s)	$2^9 \times 1/f_x$ (102.4 μ s)	$2^{16} \times 1/f_x$ (13.1 ms)	$2^{17} \times 1/f_x$ (26.2 ms)	$2^8 \times 1/f_x$ (51.2 μ s)	$2^9 \times 1/f_x$ (102.4 μ s)
1	1	1	0	$2^9 \times 1/f_x$ (102.4 μ s)	$2^{10} \times 1/f_x$ (204.8 μ s)	$2^{17} \times 1/f_x$ (26.2 ms)	$2^{18} \times 1/f_x$ (52.4 ms)	$2^9 \times 1/f_x$ (102.4 μ s)	$2^{10} \times 1/f_x$ (204.8 μ s)
1	1	1	1	$2^{11} \times 1/f_x$ (409.6 μ s)	$2^{12} \times 1/f_x$ (819.2 μ s)	$2^{19} \times 1/f_x$ (104.9 ms)	$2^{20} \times 1/f_x$ (209.7 ms)	$2^{11} \times 1/f_x$ (409.6 μ s)	$2^{12} \times 1/f_x$ (819.2 μ s)
Other than above				Setting prohibited					

- Remarks**
1. f_x : Main system clock oscillation frequency
 2. MCS : Bit 0 of oscillation mode selection register (OSMS)
 3. TCL14 to TCL17 : Bits 4 to 7 of timer clock select register 1 (TCL1)
 4. Values in parentheses when operated at $f_x = 5.0$ MHz

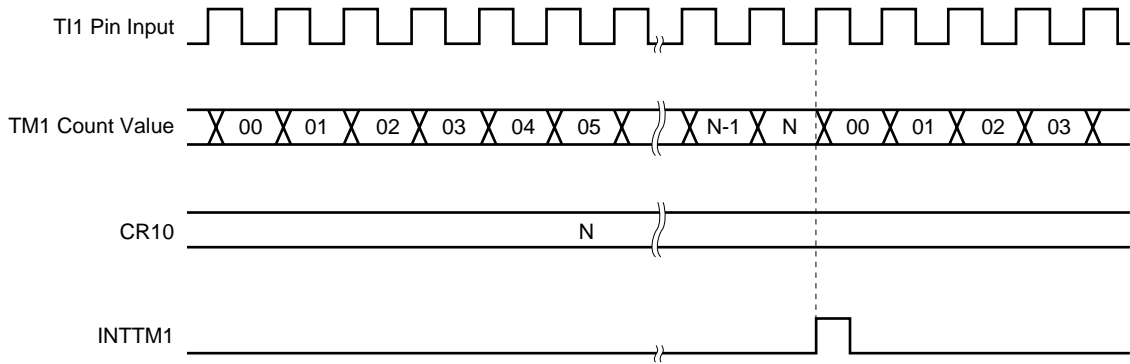
(2) External event counter operation

The external event counter counts the number of external clock pulses to be input to the T11/P33 and T12/P34 pins with 8-bit timer registers 1 and 2 (TM1 and TM2).

TM1 and TM2 are incremented each time the valid edge specified with the timer clock select register (TCL1) is input. Either the rising or falling edge can be selected.

When the TM1 and TM2 counted values match the values of 8-bit compare registers (CR10 and CR20), TM1 and TM2 are cleared to 0 and the interrupt request signals (INTTM1 and INTTM2) are generated.

Figure 9-9. External Event Counter Operation Timings (with Rising Edge Specified)



Remark N = 00H to FFH

(3) Square-wave output operation

Operates as square wave output with any selected frequency at intervals of the count value preset to 8-bit compare register 10 and 20 (CR10, CR20).

The TO1/P31 or TO2/P32 pin output status is reversed at intervals of the count value preset to CR10 or CR20 by setting bit 0 (TOE1) or bit 4 (TOE2) of the 8-bit timer output control register (TOC1) to 1. This enables a square wave with any selected frequency to be output.

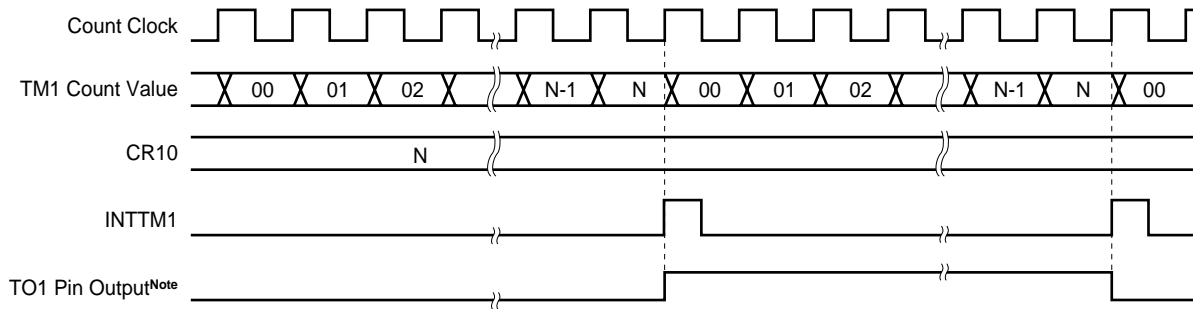
Table 9-8. 8-Bit Timer/Event Counters 1 and 2 Square-Wave Output Ranges

Minimum Pulse Width		Maximum Pulse Width		Resolution	
MCS = 1	MCS = 0	MCS = 1	MCS = 0	MCS = 1	MCS = 0
$2 \times 1/f_x$ (400 ns)	$2^2 \times 1/f_x$ (800 ns)	$2^9 \times 1/f_x$ (102.4 μ s)	$2^{10} \times 1/f_x$ (204.8 μ s)	$2 \times 1/f_x$ (400 ns)	$2^2 \times 1/f_x$ (800 ns)
$2^2 \times 1/f_x$ (800 ns)	$2^3 \times 1/f_x$ (1.6 μ s)	$2^{10} \times 1/f_x$ (204.8 μ s)	$2^{11} \times 1/f_x$ (409.6 μ s)	$2^2 \times 1/f_x$ (800 ns)	$2^3 \times 1/f_x$ (1.6 μ s)
$2^3 \times 1/f_x$ (1.6 μ s)	$2^4 \times 1/f_x$ (3.2 μ s)	$2^{11} \times 1/f_x$ (409.6 μ s)	$2^{12} \times 1/f_x$ (819.2 μ s)	$2^3 \times 1/f_x$ (1.6 μ s)	$2^4 \times 1/f_x$ (3.2 μ s)
$2^4 \times 1/f_x$ (3.2 μ s)	$2^5 \times 1/f_x$ (6.4 μ s)	$2^{12} \times 1/f_x$ (819.2 μ s)	$2^{13} \times 1/f_x$ (1.64 ms)	$2^4 \times 1/f_x$ (3.2 μ s)	$2^5 \times 1/f_x$ (6.4 μ s)
$2^5 \times 1/f_x$ (6.4 μ s)	$2^6 \times 1/f_x$ (12.8 μ s)	$2^{13} \times 1/f_x$ (1.64 ms)	$2^{14} \times 1/f_x$ (3.28 ms)	$2^5 \times 1/f_x$ (6.4 μ s)	$2^6 \times 1/f_x$ (12.8 μ s)
$2^6 \times 1/f_x$ (12.8 μ s)	$2^7 \times 1/f_x$ (25.6 μ s)	$2^{14} \times 1/f_x$ (3.28 ms)	$2^{15} \times 1/f_x$ (6.55 ms)	$2^6 \times 1/f_x$ (12.8 μ s)	$2^7 \times 1/f_x$ (25.6 μ s)
$2^7 \times 1/f_x$ (25.6 μ s)	$2^8 \times 1/f_x$ (51.2 μ s)	$2^{15} \times 1/f_x$ (6.55 ms)	$2^{16} \times 1/f_x$ (13.1 ms)	$2^7 \times 1/f_x$ (25.6 μ s)	$2^8 \times 1/f_x$ (51.2 μ s)
$2^8 \times 1/f_x$ (51.2 μ s)	$2^9 \times 1/f_x$ (102.4 μ s)	$2^{16} \times 1/f_x$ (13.1 ms)	$2^{17} \times 1/f_x$ (26.2 ms)	$2^8 \times 1/f_x$ (51.2 μ s)	$2^9 \times 1/f_x$ (102.4 μ s)
$2^9 \times 1/f_x$ (102.4 μ s)	$2^{10} \times 1/f_x$ (204.8 μ s)	$2^{17} \times 1/f_x$ (26.2 ms)	$2^{18} \times 1/f_x$ (52.4 ms)	$2^9 \times 1/f_x$ (102.4 μ s)	$2^{10} \times 1/f_x$ (204.8 μ s)
$2^{11} \times 1/f_x$ (409.6 μ s)	$2^{12} \times 1/f_x$ (819.2 μ s)	$2^{19} \times 1/f_x$ (104.9 ms)	$2^{20} \times 1/f_x$ (209.7 ms)	$2^{11} \times 1/f_x$ (409.6 μ s)	$2^{12} \times 1/f_x$ (819.2 μ s)

- Remarks**
1. f_x : Main system clock oscillation frequency
 2. MCS : Oscillation mode selection register (OSMS) bit 0
 3. Values in parentheses when operated at $f_x = 5.0$ MHz.

★

Figure 9-10. Square-Wave Output Operation Timing



Note The initial value of TO1 pin output can be set with the bits 2 and 3 (LVR1, LVS1) of 8-bit timer output control register (TOC1).

9.4.2 16-bit timer/event counter mode

When bit 2 (TMC12) of the 8-bit timer mode control register (TMC1) is set to 1, the 16-bit timer/event counter mode is set.

In this mode, the count clock is set with bits 0 to 3 (TCL10 to TCL13) of timer clock select register 1 (TCL1), and the overflow signal of 8-bit timer register 1 (TM1) becomes the count clock of 8-bit timer register 2 (TM2).

In this mode, enable/disable of the count operation is selected with bit 0 (TCE1) of TMC1.

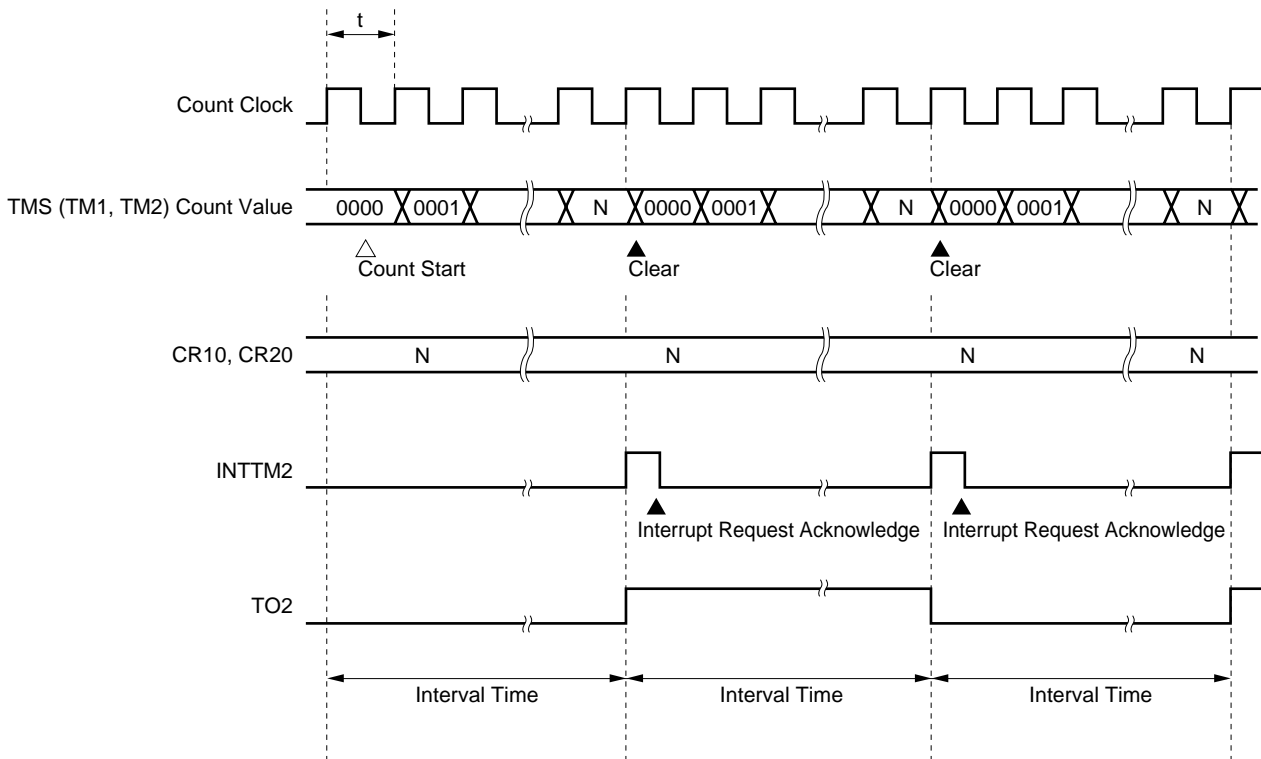
(1) Operation as interval timer

The 8-bit timer/event counter operates as an interval timer that generates interrupt requests repeatedly at intervals of the count value preset to 2-channel 8-bit compare registers (CR10 and CR20). When setting the count value, set the value of the higher 8 bits to CR20 and the value of the lower 8 bits to CR10. For the count value that can be set, refer to **Table 9-9**.

When 8-bit timer register 1 (TM1) and CR10 values match and 8-bit timer register 2 (TM2) and CR20 values match, counting continues with the TM1 and TM2 values cleared to 0 and the interrupt request signal (INTTM2) is generated. For the timing of interval timer operation, refer to **Figure 9-11**.

The count clock is selected with bits 0 to 3 (TCL10 to TCL13) of timer clock select register 1 (TCL1), and the overflow signal of TM1 becomes the count clock of TM2.

Figure 9-11. Interval Timer Operation Timing



Remark Interval time = $(N + 1) \times t$: N = 0000H to FFFFH

Caution Even if the 16-bit timer/event counter mode is used, when the TM1 count value matches the CR10 value, interrupt request (INTTM1) is generated and the F/F of 8-bit timer/event counter output control circuit 1 is inverted. Thus, when using 8-bit timer/event counter as 16-bit interval timer, set the INTTM1 mask flag TMMK1 to 1 to disable INTTM1 acknowledgment. When reading the 16-bit timer register (TMS) count value, use the 16-bit memory manipulation instruction.

Table 9-9. Interval Times when 2-Channel 8-Bit Timer/Event Counters (TM1 and TM2) are Used as 16-Bit Timer/Event Counter

TCL13	TCL12	TCL11	TCL10	Minimum Interval Time		Maximum Interval Time		Resolution	
				MCS = 1	MCS = 0	MCS = 1	MCS = 0	MCS = 1	MCS = 0
0	0	0	0	TI1 input cycle		$2^8 \times$ TI1 input cycle		TI1 input edge cycle	
0	0	0	1	TI1 input cycle		$2^8 \times$ TI1 input cycle		TI1 input edge cycle	
0	1	1	0	$2 \times 1/f_x$ (400 ns)	$2^2 \times 1/f_x$ (800 ns)	$2^{17} \times 1/f_x$ (26.2 ms)	$2^{18} \times 1/f_x$ (52.4 ms)	$2 \times 1/f_x$ (400 ns)	$2^2 \times 1/f_x$ (800 ns)
0	1	1	1	$2^2 \times 1/f_x$ (800 ns)	$2^3 \times 1/f_x$ (1.6 μ s)	$2^{18} \times 1/f_x$ (52.4 ms)	$2^{19} \times 1/f_x$ (104.9 ms)	$2^2 \times 1/f_x$ (800 ns)	$2^3 \times 1/f_x$ (1.6 μ s)
1	0	0	0	$2^3 \times 1/f_x$ (1.6 μ s)	$2^4 \times 1/f_x$ (3.2 μ s)	$2^{19} \times 1/f_x$ (104.9 ms)	$2^{20} \times 1/f_x$ (209.7 ms)	$2^3 \times 1/f_x$ (1.6 μ s)	$2^4 \times 1/f_x$ (3.2 μ s)
1	0	0	1	$2^4 \times 1/f_x$ (3.2 μ s)	$2^5 \times 1/f_x$ (6.4 μ s)	$2^{20} \times 1/f_x$ (209.7 ms)	$2^{21} \times 1/f_x$ (419.4 ms)	$2^4 \times 1/f_x$ (3.2 μ s)	$2^5 \times 1/f_x$ (6.4 μ s)
1	0	1	0	$2^5 \times 1/f_x$ (6.4 μ s)	$2^6 \times 1/f_x$ (12.8 μ s)	$2^{21} \times 1/f_x$ (419.4 ms)	$2^{22} \times 1/f_x$ (838.9 ms)	$2^5 \times 1/f_x$ (6.4 μ s)	$2^6 \times 1/f_x$ (12.8 μ s)
1	0	1	1	$2^6 \times 1/f_x$ (12.8 μ s)	$2^7 \times 1/f_x$ (25.6 μ s)	$2^{22} \times 1/f_x$ (838.9 ms)	$2^{23} \times 1/f_x$ (1.7 s)	$2^6 \times 1/f_x$ (12.8 μ s)	$2^7 \times 1/f_x$ (25.6 μ s)
1	1	0	0	$2^7 \times 1/f_x$ (25.6 μ s)	$2^8 \times 1/f_x$ (51.2 μ s)	$2^{23} \times 1/f_x$ (1.7 s)	$2^{24} \times 1/f_x$ (3.4 s)	$2^7 \times 1/f_x$ (25.6 μ s)	$2^8 \times 1/f_x$ (51.2 μ s)
1	1	0	1	$2^8 \times 1/f_x$ (51.2 μ s)	$2^9 \times 1/f_x$ (102.4 μ s)	$2^{24} \times 1/f_x$ (3.4 s)	$2^{25} \times 1/f_x$ (6.7 s)	$2^8 \times 1/f_x$ (51.2 μ s)	$2^9 \times 1/f_x$ (102.4 μ s)
1	1	1	0	$2^9 \times 1/f_x$ (102.4 μ s)	$2^{10} \times 1/f_x$ (204.8 μ s)	$2^{25} \times 1/f_x$ (6.7 s)	$2^{26} \times 1/f_x$ (13.4 s)	$2^9 \times 1/f_x$ (102.4 μ s)	$2^{10} \times 1/f_x$ (204.8 μ s)
1	1	1	1	$2^{11} \times 1/f_x$ (409.6 μ s)	$2^{12} \times 1/f_x$ (819.2 μ s)	$2^{27} \times 1/f_x$ (26.8 s)	$2^{28} \times 1/f_x$ (53.7 s)	$2^{11} \times 1/f_x$ (409.6 μ s)	$2^{12} \times 1/f_x$ (819.2 μ s)
Other than above				Setting prohibited					

- Remarks**
1. f_x : Main system clock oscillation frequency
 2. MCS : Oscillation mode selection register (OSMS) bit 0
 3. TCL10 to TCL13 : Bits 0 to 3 of timer clock select register (TCL1)
 4. Values in parentheses when operated at $f_x = 5.0$ MHz.

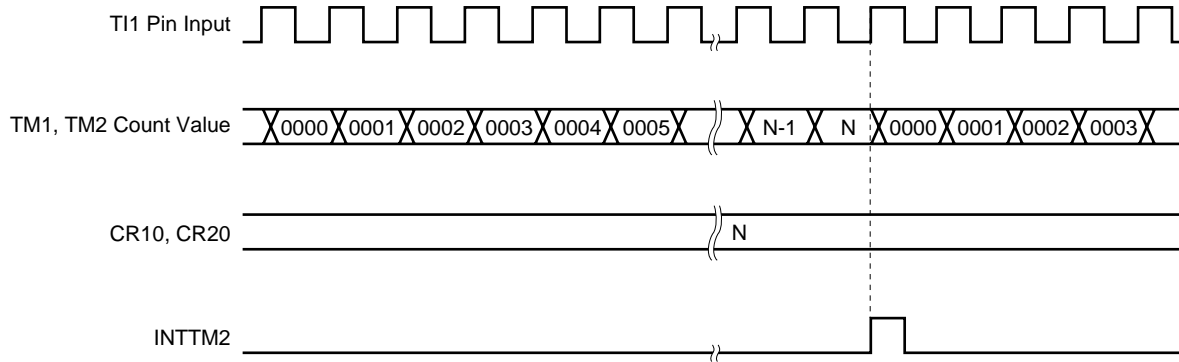
(2) External event counter operations

The external event counter counts the number of external clock pulses to be input to the TI1/P33 pin with 2-channel 8-bit timer registers 1 and 2 (TM1 and TM2).

TM1 is incremented each time the valid edge specified with the timer clock select register 1 (TCL1) is input. When TM1 overflows, TM2 is incremented with the overflow signal as the count clock. Either the rising or falling edge can be selected.

When the TM1 and TM2 counted values match the values of 8-bit compare registers 10 and 20 (CR10 and CR20), TM1 and TM2 are cleared to 0 and the interrupt request signal (INTTM2) is generated.

Figure 9-12. External Event Counter Operation Timings (with Rising Edge Specified)



Caution Even if the 16-bit timer/event counter mode is used, when the TM1 count value matches the CR10 value, interrupt request (INTTM1) is generated and the F/F of 8-bit timer/event counter output control circuit 1 is inverted. Thus, when using 8-bit timer/event counter as 16-bit interval timer, set the INTTM1 mask flag TMMK1 to 1 to disable INTTM1 acknowledgment. When reading the 16-bit timer register (TMS) count value, use the 16-bit memory manipulation instruction.

(3) Square-wave output operation

Operates as square wave output with any selected frequency at intervals of the count value preset to 8-bit compare registers 10 and 20 (CR10, CR20). When setting the count value, set the value of higher 8 bits to CR20 and the value of lower 8 bits to CR10.

The TO2/P32 pin output status is reversed at intervals of the count value preset to CR10 and CR20 by setting bit 4 (TOE2) of the 8-bit timer output control register (TOC1) to 1. This enables a square wave with any selected frequency to be output.

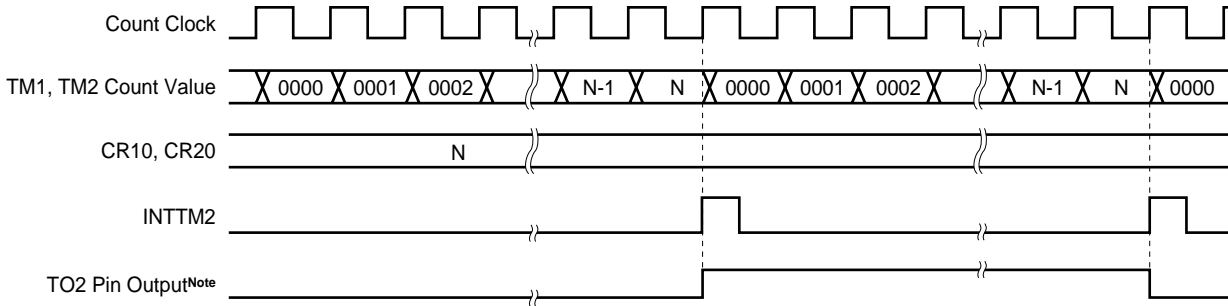
Table 9-10. Square-Wave Output Ranges when 2-Channel 8-Bit Timer/Event Counters (TM1 and TM2) are Used as 16-Bit Timer/Event Counter

Minimum Pulse Width		Maximum Pulse Width		Resolution	
MCS = 1	MCS = 0	MCS = 1	MCS = 0	MCS = 1	MCS = 0
$2 \times 1/f_x$ (400 ns)	$2^2 \times 1/f_x$ (800 ns)	$2^{17} \times 1/f_x$ (26.2 ms)	$2^{18} \times 1/f_x$ (52.4 ms)	$2 \times 1/f_x$ (400 ns)	$2^2 \times 1/f_x$ (800 ns)
$2^2 \times 1/f_x$ (800 ns)	$2^3 \times 1/f_x$ (1.6 μ s)	$2^{18} \times 1/f_x$ (52.4 ms)	$2^{19} \times 1/f_x$ (104.9 ms)	$2^2 \times 1/f_x$ (800 ns)	$2^3 \times 1/f_x$ (1.6 μ s)
$2^3 \times 1/f_x$ (1.6 μ s)	$2^4 \times 1/f_x$ (3.2 μ s)	$2^{19} \times 1/f_x$ (104.9 ms)	$2^{20} \times 1/f_x$ (209.7 ms)	$2^3 \times 1/f_x$ (1.6 μ s)	$2^4 \times 1/f_x$ (3.2 μ s)
$2^4 \times 1/f_x$ (3.2 μ s)	$2^5 \times 1/f_x$ (6.4 μ s)	$2^{20} \times 1/f_x$ (209.7 ms)	$2^{21} \times 1/f_x$ (419.4 ms)	$2^4 \times 1/f_x$ (3.2 μ s)	$2^5 \times 1/f_x$ (6.4 μ s)
$2^5 \times 1/f_x$ (6.4 μ s)	$2^6 \times 1/f_x$ (12.8 μ s)	$2^{21} \times 1/f_x$ (419.4 ms)	$2^{22} \times 1/f_x$ (838.9 ms)	$2^5 \times 1/f_x$ (6.4 μ s)	$2^6 \times 1/f_x$ (12.8 μ s)
$2^6 \times 1/f_x$ (12.8 μ s)	$2^7 \times 1/f_x$ (25.6 μ s)	$2^{22} \times 1/f_x$ (838.9 ms)	$2^{23} \times 1/f_x$ (1.7 s)	$2^6 \times 1/f_x$ (12.8 μ s)	$2^7 \times 1/f_x$ (25.6 μ s)
$2^7 \times 1/f_x$ (25.6 μ s)	$2^8 \times 1/f_x$ (51.2 μ s)	$2^{23} \times 1/f_x$ (1.7 s)	$2^{24} \times 1/f_x$ (3.4 s)	$2^7 \times 1/f_x$ (25.6 μ s)	$2^8 \times 1/f_x$ (51.2 μ s)
$2^8 \times 1/f_x$ (51.2 μ s)	$2^9 \times 1/f_x$ (102.4 μ s)	$2^{24} \times 1/f_x$ (3.4 s)	$2^{25} \times 1/f_x$ (6.7 s)	$2^8 \times 1/f_x$ (51.2 μ s)	$2^9 \times 1/f_x$ (102.4 μ s)
$2^9 \times 1/f_x$ (102.4 μ s)	$2^{10} \times 1/f_x$ (204.8 μ s)	$2^{25} \times 1/f_x$ (6.7 s)	$2^{26} \times 1/f_x$ (13.4 s)	$2^9 \times 1/f_x$ (102.4 μ s)	$2^{10} \times 1/f_x$ (204.8 μ s)
$2^{11} \times 1/f_x$ (409.6 μ s)	$2^{12} \times 1/f_x$ (819.2 μ s)	$2^{27} \times 1/f_x$ (26.8 s)	$2^{28} \times 1/f_x$ (53.7 s)	$2^{11} \times 1/f_x$ (409.6 μ s)	$2^{12} \times 1/f_x$ (819.2 μ s)

- Remarks**
1. f_x : Main system clock oscillation frequency
 2. MCS : Oscillation mode selection register (OSMS) bit 0
 3. Values in parentheses when operated at $f_x = 5.0$ MHz.

★

Figure 9-13. Square-Wave Output Operation Timing



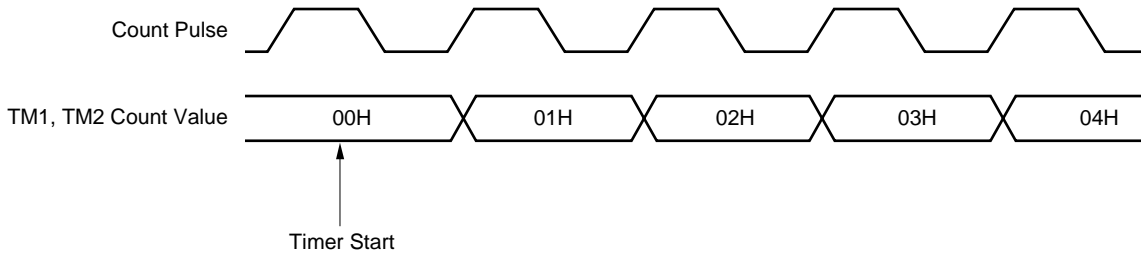
Note The initial value of TO2 pin output can be set with the bits 6 and 7 (LVR2, LVS2) of 8-bit timer output control register (TOC1).

9.5 Cautions on 8-Bit Timer/Event Counters 1 and 2

(1) Timer start errors

An error with a maximum of one clock may occur concerning the time required for a match signal to be generated after timer start. This is because 8-bit timer registers 1 and 2 (TM1 and TM2) starts asynchronously with the count pulse.

Figure 9-14. 8-Bit Timer Registers 1 and 2 Start Timing



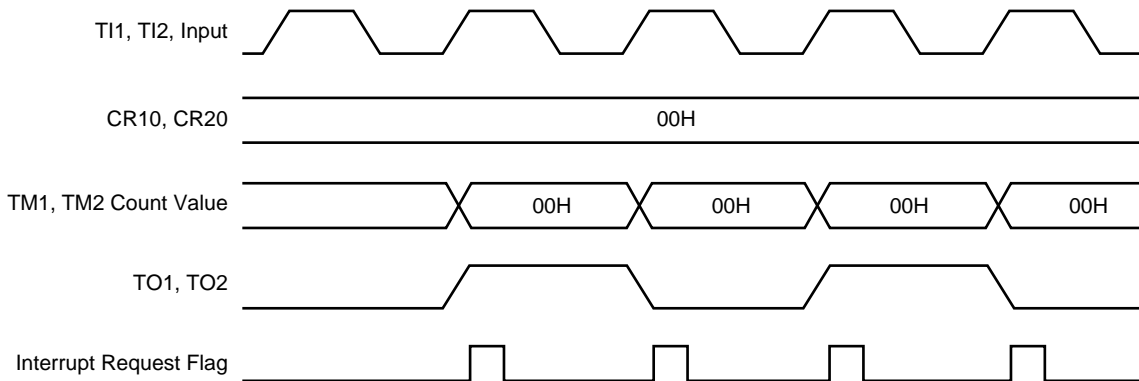
(2) 8-bit compare register 10 and 20 setting

The 8-bit compare registers 10 and 20 (CR10 and CR20) can be set to 00H.

Thus, when these 8-bit compare registers are used as event counters, one-pulse count operation can be carried out.

When the 8-bit compare register is used as 16-bit timer/event counter, write data to CR10 and CR20 after setting bit 0 (TCE1) of the 8-bit timer mode control register 1 to 0 and stopping timer operation.

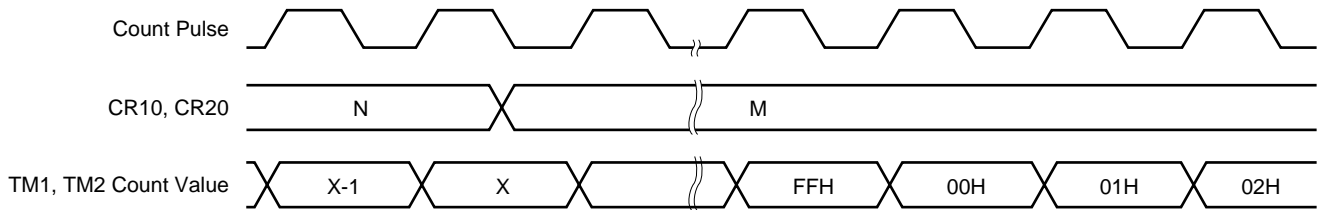
Figure 9-15. Event Counter Operation Timing



(3) Operation after compare register change during timer count operation

If the values after the 8-bit compare registers 10 and 20 (CR10 and CR20) are changed are smaller than those of 8-bit timer registers (TM1 and TM2), TM1 and TM2 continue counting, overflow and then restart counting from 0. Thus, if the value (M) after CR10 and CR20 change is smaller than value (N) before the change, it is necessary to restart the timer after changing CR10 and CR20.

Figure 9-16. Timing after Compare Register Change during Timer Count Operation



Remark $N > X > M$

[MEMO]

CHAPTER 10 WATCH TIMER

10.1 Watch Timer Functions

The watch timer has the following functions.

- Watch timer
- Interval timer

The watch timer and the interval timer can be used simultaneously.

(1) Watch timer

When the 32.768 kHz subsystem clock is used, a flag (WTIF) is set at 0.5 second or 0.25 second intervals. When the 4.19 MHz (standard: 4.194304 MHz) main system clock is used, a flag (WTIF) is set at 0.5 second or 0.25 second intervals.

Caution 0.5-second intervals cannot be generated with the 5.0-MHz main system clock. You should switch to the 32.768 kHz subsystem clock to generate 0.5-second intervals.

(2) Interval timer

Interrupt requests (INTTM3) are generated at the preset time interval.

Table 10-1. Interval Timer Interval Time

Interval Time	When operated at $f_{xx} = 5.0 \text{ MHz}$	When operated at $f_{xx} = 4.19 \text{ MHz}$	When operated at $f_{XT} = 32.768 \text{ kHz}$
$2^4 \times 1/f_w$	410 μs	488 μs	488 μs
$2^5 \times 1/f_w$	819 μs	977 μs	977 μs
$2^6 \times 1/f_w$	1.64 ms	1.95 ms	1.95 ms
$2^7 \times 1/f_w$	3.28 ms	3.91 ms	3.91 ms
$2^8 \times 1/f_w$	6.55 ms	7.81 ms	7.81 ms
$2^9 \times 1/f_w$	13.1 ms	15.6 ms	15.6 ms

Remark f_{xx} : Main system clock frequency (f_x or $f_x/2$)
 f_x : Main system clock oscillation frequency
 f_{XT} : Subsystem clock oscillation frequency
 f_w : Watch timer clock frequency ($f_{xx}/2^7$ or f_{XT})

10.2 Watch Timer Configuration

The watch timer consists of the following hardware.

Table 10-2. Watch Timer Configuration

Item	Configuration
Counter	5 bits × 1
Control register	Timer clock select register 2 (TCL2) Watch timer mode control register (TMC2)

10.3 Watch Timer Control Registers

The following two types of registers are used to control the watch timer.

- Timer clock select register 2 (TCL2)
- Watch timer mode control register (TMC2)

(1) Timer clock select register 2 (TCL2) (Refer to Figure 10-2.)

This register sets the watch timer count clock.

TCL2 is set with an 8-bit memory manipulation instruction.

$\overline{\text{RESET}}$ input sets TCL2 to 00H.

Remark Besides setting the watch timer count clock, TCL2 sets the watchdog timer count clock and buzzer output frequency.

Figure 10-1. Watch Timer Block Diagram

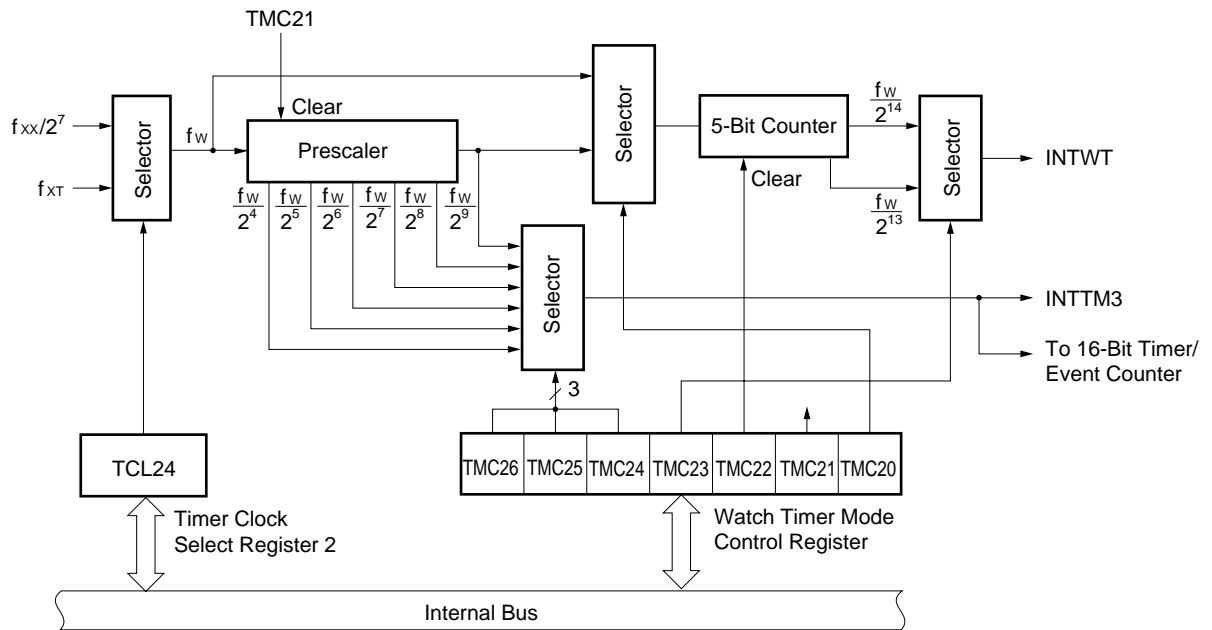


Figure 10-2. Timer Clock Select Register 2 Format

Symbol	7	6	5	4	3	2	1	0	Address	After Reset	R/W
TCL2	TCL27	TCL26	TCL25	TCL24	0	TCL22	TCL21	TCL20	FF42H	00H	R/W

TCL22	TCL21	TCL20	Watchdog Timer Count Clock Selection		
				MCS = 1	MCS = 0
0	0	0	$f_{xx}/2^3$	$f_x/2^3$ (625 kHz)	$f_x/2^4$ (313 kHz)
0	0	1	$f_{xx}/2^4$	$f_x/2^4$ (313 kHz)	$f_x/2^5$ (156 kHz)
0	1	0	$f_{xx}/2^5$	$f_x/2^5$ (156 kHz)	$f_x/2^6$ (78.1 kHz)
0	1	1	$f_{xx}/2^6$	$f_x/2^6$ (78.1 kHz)	$f_x/2^7$ (39.1 kHz)
1	0	0	$f_{xx}/2^7$	$f_x/2^7$ (39.1 kHz)	$f_x/2^8$ (19.5 kHz)
1	0	1	$f_{xx}/2^8$	$f_x/2^8$ (19.5 kHz)	$f_x/2^9$ (9.8 kHz)
1	1	0	$f_{xx}/2^9$	$f_x/2^9$ (9.8 kHz)	$f_x/2^{10}$ (4.9 kHz)
1	1	1	$f_{xx}/2^{11}$	$f_x/2^{11}$ (2.4 kHz)	$f_x/2^{12}$ (1.2 kHz)

TCL24	Watchdog Timer Count Clock Selection		
		MCS = 1	MCS = 0
0	$f_{xx}/2^7$	$f_x/2^7$ (39.1 kHz)	$f_x/2^8$ (19.5 kHz)
1	f_{XT} (32.768 kHz)		

TCL27	TCL26	TCL25	Buzzer Output Frequency Selection		
				MCS = 1	MCS = 0
0	×	×	Buzzer output disable		
1	0	0	$f_{xx}/2^9$	$f_x/2^9$ (9.8 kHz)	$f_x/2^{10}$ (4.9 kHz)
1	0	1	$f_{xx}/2^{10}$	$f_x/2^{10}$ (4.9 kHz)	$f_x/2^{11}$ (2.4 kHz)
1	1	0	$f_{xx}/2^{11}$	$f_x/2^{11}$ (2.4 kHz)	$f_x/2^{12}$ (1.2 kHz)
1	1	1	Setting prohibited		

Caution When rewriting TCL2 to other data, stop the timer operation beforehand.

- Remarks**
1. f_{xx} : Main system clock frequency (f_x or $f_x/2$)
 2. f_x : Main system clock oscillation frequency
 3. f_{XT} : Subsystem clock oscillation frequency
 4. × : Don't care
 5. MCS : Bit 0 of oscillation mode selection register (OSMS)
 6. Figures in parentheses apply to operation with $f_x = 5.0$ MHz or $f_{XT} = 32.768$ kHz.

(2) Watch timer mode control register (TMC2)

This register sets the watch timer operating mode, watch flag set time and prescaler interval time and enables/disables prescaler and 5-bit counter operations. TMC2 is set with a 1-bit or 8-bit memory manipulation instruction.

RESET input sets TMC2 to 00H.

Figure 10-3. Watch Timer Mode Control Register Format

Symbol	7	6	5	4	3	2	1	0	Address	After Reset	R/W
TMC2	0	TMC26	TMC25	TMC24	TMC23	TMC22	TMC21	TMC20	FF4AH	00H	R/W

TMC20	Watch Operating Mode Selection
0	Normal operating mode (flag set at $f_w/2^{14}$)
1	Fast feed operating mode (flag set at $f_w/2^5$)

TMC21	Prescaler Operation Control
0	Clear after operation stop
1	Operation enable

TMC22	5-Bit Counter Operation Control
0	Clear after operation stop
1	Operation enable

TMC23	Watch Flag Set Time Selection		
	$f_{xx} = 5.0 \text{ MHz Operation}$	$f_{xx} = 4.19 \text{ MHz Operation}$	$f_{XT} = 32.768 \text{ kHz Operation}$
	0	$2^{14}/f_w$ (0.4 sec)	$2^{14}/f_w$ (0.5 sec)
1	$2^{13}/f_w$ (0.2 sec)	$2^{13}/f_w$ (0.25 sec)	$2^{13}/f_w$ (0.25 sec)

TMC26	TMC25	TMC24	Prescaler Interval Time Selection		
			$f_{xx} = 5.0 \text{ MHz Operation}$	$f_{xx} = 4.19 \text{ MHz Operation}$	$f_{XT} = 32.768 \text{ kHz Operation}$
0	0	0	$2^4/f_w$ (410 μs)	$2^4/f_w$ (488 μs)	$2^4/f_w$ (488 μs)
0	0	1	$2^5/f_w$ (819 μs)	$2^5/f_w$ (977 μs)	$2^5/f_w$ (977 μs)
0	1	0	$2^6/f_w$ (1.64 ms)	$2^6/f_w$ (1.95 ms)	$2^6/f_w$ (1.95 ms)
0	1	1	$2^7/f_w$ (3.28 ms)	$2^7/f_w$ (3.91 ms)	$2^7/f_w$ (3.91 ms)
1	0	0	$2^8/f_w$ (6.55 ms)	$2^8/f_w$ (7.81 ms)	$2^8/f_w$ (7.81 ms)
1	0	1	$2^9/f_w$ (13.1 ms)	$2^9/f_w$ (15.6 ms)	$2^9/f_w$ (15.6 ms)
Other than above			Setting prohibited		

Caution When the watch timer is used, the prescaler should not be cleared frequently.

- Remarks**
1. f_w : Watch timer clock frequency ($f_{xx}/2^7$ or f_{XT})
 2. f_{xx} : Main system clock frequency (f_x or $f_x/2$)
 3. f_x : Main system clock oscillation frequency
 4. f_{XT} : Subsystem clock oscillation frequency

10.4 Watch Timer Operations

10.4.1 Watch timer operation

When the 32.768-kHz subsystem clock or 4.19-MHz main system clock is used, the timer operates as a watch timer with a 0.5-second or 0.25-second interval.

The watch timer sets the test input flag (WTIF) to 1 at the constant time interval. The standby state (STOP mode/ HALT mode) can be cleared by setting WTIF to 1.

When bit 2 (TMC22) of the watch timer mode control register (TMC2) is set to 0, the 5-bit counter is cleared and the count operation stops.

For simultaneous operation of the interval timer, zero-second start can be achieved by setting TMC22 to 0 (maximum error: 26.2 ms when operated at $f_{xx} = 5.0$ MHz).

10.4.2 Interval timer operation

The watch timer operates as interval timer which generates interrupt requests repeatedly at an interval of the preset count value.

The interval time can be selected with bits 4 to 6 (TMC24 to TMC26) of the watch timer mode control register.

Table 10-3. Interval Timer Interval Time

TMC26	TMC25	TMC24	Interval Time	When operated at $f_{xx} = 5.0$ MHz	When operated at $f_{xx} = 4.19$ MHz	When operated at $f_{XT} = 32.768$ kHz
0	0	0	$2^4 \times 1/f_w$	410 μ s	488 μ s	488 μ s
0	0	1	$2^5 \times 1/f_w$	819 μ s	977 μ s	977 μ s
0	1	0	$2^6 \times 1/f_w$	1.64 ms	1.95 ms	1.95 ms
0	1	1	$2^7 \times 1/f_w$	3.28 ms	3.91 ms	3.91 ms
1	0	0	$2^8 \times 1/f_w$	6.55 ms	7.81 ms	7.81 ms
1	0	1	$2^9 \times 1/f_w$	13.1 ms	15.6 ms	15.6 ms
Other than above			Setting prohibited			

Remark f_{xx} : Main system clock frequency (f_x or $f_x/2$)
 f_x : Main system clock oscillation frequency
 f_{XT} : Subsystem clock oscillation frequency
 f_w : Watch timer clock frequency ($f_{xx}/2^7$ or f_{XT})

CHAPTER 11 WATCHDOG TIMER

11.1 Watchdog Timer Functions

The watchdog timer has the following functions.

- Watchdog timer
- Interval timer

Caution Select the watchdog timer mode or the interval timer mode with the watchdog timer mode register (WDTM) (The watchdog timer and interval timer cannot be used at the same time).

(1) Watchdog timer mode

An inadvertent program loop (runaway) is detected. Upon detection of the runaway, a non-maskable interrupt request or RESET can be generated.

Table 11-1. Watchdog Timer Runaway Detection Times

Runaway Detection Time	MCS = 1	MCS = 0
$2^{11} \times 1/f_{xx}$	$2^{11} \times 1/f_x$ (410 μ s)	$2^{12} \times 1/f_x$ (819 μ s)
$2^{12} \times 1/f_{xx}$	$2^{12} \times 1/f_x$ (819 μ s)	$2^{13} \times 1/f_x$ (1.64 ms)
$2^{13} \times 1/f_{xx}$	$2^{13} \times 1/f_x$ (1.64 ms)	$2^{14} \times 1/f_x$ (3.28 ms)
$2^{14} \times 1/f_{xx}$	$2^{14} \times 1/f_x$ (3.28 ms)	$2^{15} \times 1/f_x$ (6.55 ms)
$2^{15} \times 1/f_{xx}$	$2^{15} \times 1/f_x$ (6.55 ms)	$2^{16} \times 1/f_x$ (13.1 ms)
$2^{16} \times 1/f_{xx}$	$2^{16} \times 1/f_x$ (13.1 ms)	$2^{17} \times 1/f_x$ (26.2 ms)
$2^{17} \times 1/f_{xx}$	$2^{17} \times 1/f_x$ (26.2 ms)	$2^{18} \times 1/f_x$ (52.4 ms)
$2^{19} \times 1/f_{xx}$	$2^{19} \times 1/f_x$ (104.9 ms)	$2^{20} \times 1/f_x$ (209.7 ms)

- Remarks**
1. f_{xx} : Main system clock frequency (f_x or $f_x/2$)
 2. f_x : Main system clock oscillation frequency
 3. MCS : Bit 0 of oscillation mode selection register (OSMS)
 4. Figures in parentheses apply to operation with $f_x = 5.0$ MHz.

(2) Interval timer mode

Interrupt requests are generated at the preset time intervals.

Table 11-2. Interval Times

Interval Time	MCS = 1	CS = 0
$2^{11} \times 1/f_{xx}$	$2^{11} \times 1/f_x$ (410 μ s)	$2^{12} \times 1/f_x$ (819 μ s)
$2^{12} \times 1/f_{xx}$	$2^{12} \times 1/f_x$ (819 μ s)	$2^{13} \times 1/f_x$ (1.64 ms)
$2^{13} \times 1/f_{xx}$	$2^{13} \times 1/f_x$ (1.64 ms)	$2^{14} \times 1/f_x$ (3.28 ms)
$2^{14} \times 1/f_{xx}$	$2^{14} \times 1/f_x$ (3.28 ms)	$2^{15} \times 1/f_x$ (6.55 ms)
$2^{15} \times 1/f_{xx}$	$2^{15} \times 1/f_x$ (6.55 ms)	$2^{16} \times 1/f_x$ (13.1 ms)
$2^{16} \times 1/f_{xx}$	$2^{16} \times 1/f_x$ (13.1 ms)	$2^{17} \times 1/f_x$ (26.2 ms)
$2^{17} \times 1/f_{xx}$	$2^{17} \times 1/f_x$ (26.2 ms)	$2^{18} \times 1/f_x$ (52.4 ms)
$2^{19} \times 1/f_{xx}$	$2^{19} \times 1/f_x$ (104.9 ms)	$2^{20} \times 1/f_x$ (209.7 ms)

- Remarks**
1. f_{xx} : Main system clock frequency (f_x or $f_x/2$)
 2. f_x : Main system clock oscillation frequency
 3. MCS : Oscillation mode selection register bit 0
 4. Figures in parentheses apply to operation with $f_x = 5.0$ MHz.

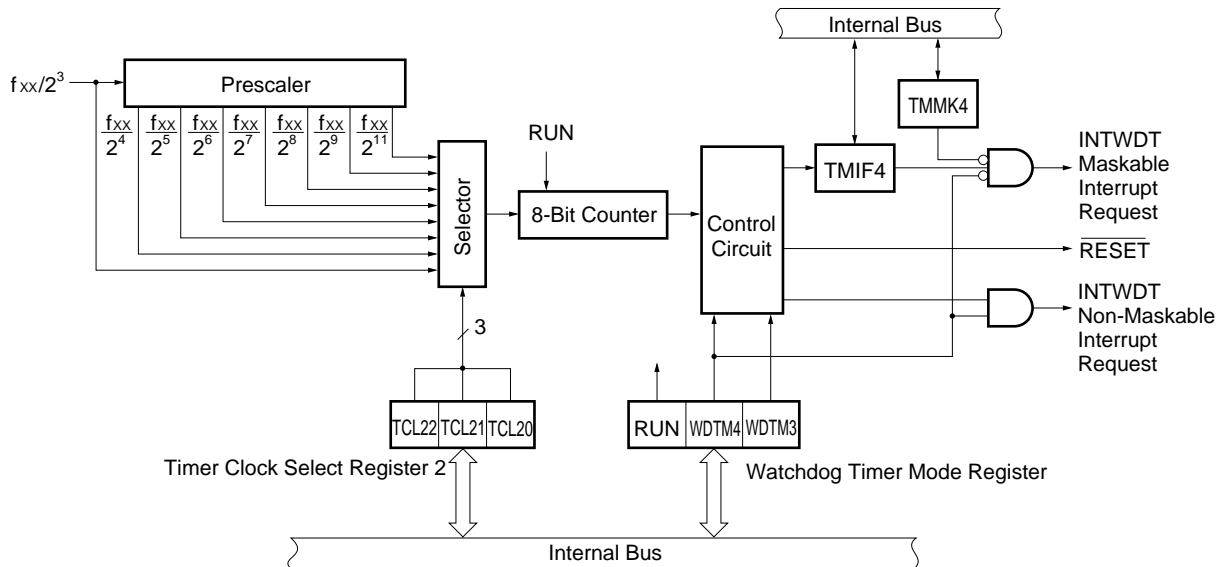
11.2 Watchdog Timer Configuration

The watchdog timer consists of the following hardware.

Table 11-3. Watchdog Timer Configuration

Item	Configuration
Control register	Timer clock select register 2 (TCL2) Watchdog timer mode control register (WDTM)

Figure 11-1. Watchdog Timer Block Diagram



11.3 Watchdog Timer Control Registers

The following two types of registers are used to control the watchdog timer.

- Timer clock select register 2 (TCL2)
- Watchdog timer mode register (WDTM)

(1) Timer clock select register 2 (TCL2)

This register sets the watchdog timer count clock.

TCL2 is set with 8-bit memory manipulation instruction.

$\overline{\text{RESET}}$ input sets TCL2 to 00H.

Remark Besides setting the watchdog timer count clock, TCL2 sets the watch timer count clock and buzzer output frequency.

Figure 11-2. Timer Clock Select Register 2 Format

Symbol	7	6	5	4	3	2	1	0	Address	After Reset	R/W
TCL2	TCL27	TCL26	TCL25	TCL24	0	TCL22	TCL21	TCL20	FF42H	00H	R/W

TCL22	TCL21	TCL20	Watchdog Timer Count Clock Selection		
			MCS = 1		MCS = 0
0	0	0	$f_{xx}/2^3$	$f_x/2^3$ (625 kHz)	$f_x/2^4$ (313 kHz)
0	0	1	$f_{xx}/2^4$	$f_x/2^4$ (313 kHz)	$f_x/2^5$ (156 kHz)
0	1	0	$f_{xx}/2^5$	$f_x/2^5$ (156 kHz)	$f_x/2^6$ (78.1 kHz)
0	1	1	$f_{xx}/2^6$	$f_x/2^6$ (78.1 kHz)	$f_x/2^7$ (39.1 kHz)
1	0	0	$f_{xx}/2^7$	$f_x/2^7$ (39.1 kHz)	$f_x/2^8$ (19.5 kHz)
1	0	1	$f_{xx}/2^8$	$f_x/2^8$ (19.5 kHz)	$f_x/2^9$ (9.8 kHz)
1	1	0	$f_{xx}/2^9$	$f_x/2^9$ (9.8 kHz)	$f_x/2^{10}$ (4.9 kHz)
1	1	1	$f_{xx}/2^{11}$	$f_x/2^{11}$ (2.4 kHz)	$f_x/2^{12}$ (1.2 kHz)

TCL24	Watchdog Timer Count Clock Selection		
	MCS = 1		MCS = 0
0	$f_{xx}/2^7$	$f_x/2^7$ (39.1 kHz)	$f_x/2^8$ (19.5 kHz)
1	f_{xT} (32.768 kHz)		

TCL27	TCL26	TCL25	Buzzer Output Frequency Selection		
			MCS = 1		MCS = 0
0	×	×	Buzzer output disable		
1	0	0	$f_{xx}/2^9$	$f_x/2^9$ (9.8 kHz)	$f_x/2^{10}$ (4.9 kHz)
1	0	1	$f_{xx}/2^{10}$	$f_x/2^{10}$ (4.9 kHz)	$f_x/2^{11}$ (2.4 kHz)
1	1	0	$f_{xx}/2^{11}$	$f_x/2^{11}$ (2.4 kHz)	$f_x/2^{12}$ (1.2 kHz)
1	1	1	Setting prohibited		

Caution When rewriting TCL2 to other data, stop the timer operation beforehand.

- Remarks**
1. f_{xx} : Main system clock frequency (f_x or $f_x/2$)
 2. f_x : Main system clock oscillation frequency
 3. f_{xT} : Subsystem clock oscillation frequency
 4. × : Don't care
 5. MCS : Bit 0 of oscillation mode selection register (OSMS)
 6. Figures in parentheses apply to operation with $f_x = 5.0$ MHz or $f_{xT} = 32.768$ kHz.

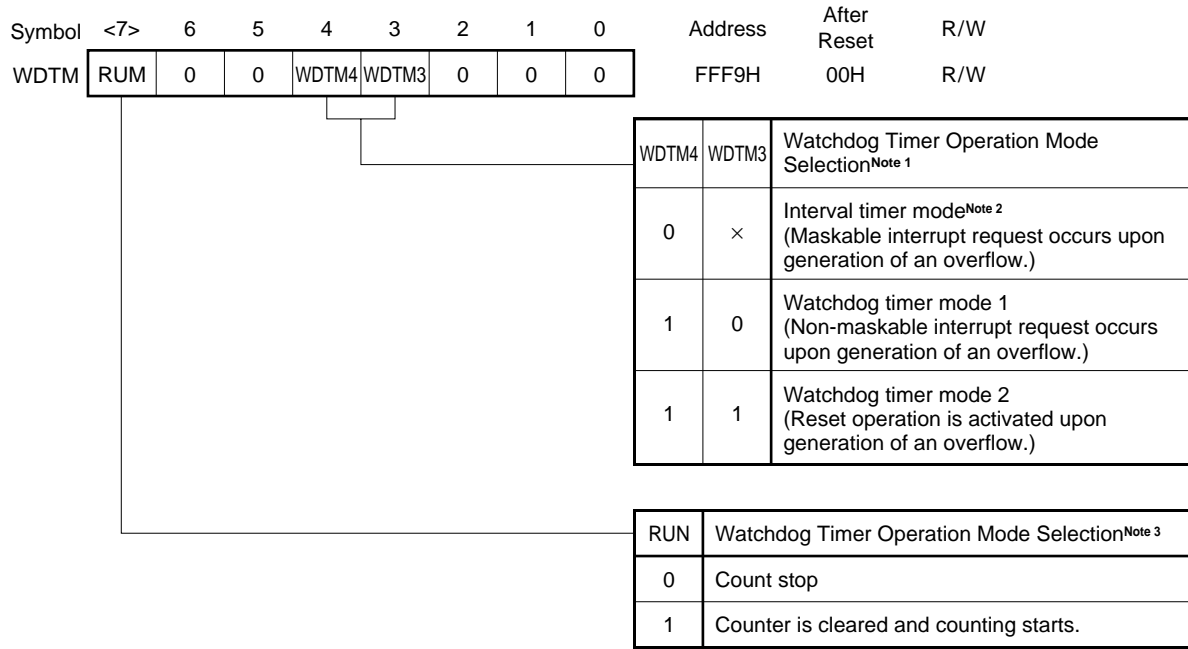
(2) Watchdog timer mode register (WDTM)

This register sets the watchdog timer operating mode and enables/disables counting.

WDTM is set with a 1-bit or 8-bit memory manipulation instruction.

$\overline{\text{RESET}}$ input sets WDTM to 00H.

Figure 11-3. Watchdog Timer Mode Register Format



- Notes**
- Once set to 1, WDTM3 and WDTM4 cannot be cleared to 0 by software.
 - The watchdog timer starts operating as an interval timer as soon as RUN has been set to 1.
 - Once set to 1, RUN cannot be cleared to 0 by software.
Thus, once counting starts, counting can only be stopped by $\overline{\text{RESET}}$ input.

- Cautions**
- When 1 is set in RUN so that the watchdog timer is cleared, the actual overflow time is up to 0.5 % shorter than the time set by timer clock select register 2 (TCL2).
 - To use watchdog timer modes 1 and 2, make sure that the interrupt request flag (TMIF4) is 0, and then set WDTM4 to 1.
If WDTM4 is set to 1 when TMIF4 is 1, the non-maskable interrupt request occurs, regardless of the contents of WDTM3.

Remark ×: Don't care

11.4 Watchdog Timer Operations

11.4.1 Watchdog timer operation

When bit 4 (WDTM4) of the watchdog timer mode register (WDTM) is set to 1, the watchdog timer is operated to detect any runaway.

The watchdog timer count clock (runaway detection time interval) can be selected with bits 0 to 2 (TCL20 to TCL22) of the timer clock select register 2 (TCL2).

Watchdog timer starts by setting bit 7 (RUN) of WDTM to 1. After the watchdog timer is started, set RUN to 1 within the set runaway detection time interval. The watchdog timer can be cleared and counting is started by setting RUN to 1. If RUN is not set to 1 and the runaway detection time is past, system reset or a non-maskable interrupt request is generated according to the WDTM bit 3 (WDTM3) value.

By setting RUN to 1, the watchdog timer can be cleared.

The watchdog timer continues operating in the HALT mode but it stops in the STOP mode. Thus, set RUN to 1 before the STOP mode is set, clear the watchdog timer and then execute the STOP instruction.

- Cautions**
1. The actual runaway detection time may be shorter than the set time by a maximum of 0.5 %.
 2. When the subsystem clock is selected for CPU clock, watchdog timer count operation is stopped.

Table 11-4. Watchdog Timer Runaway Detection Times

TCL22	TCL21	TCL20	Runaway Detection Time	MCS = 1	MCS = 0
0	0	0	$2^{11} \times 1/f_{xx}$	$2^{11} \times 1/f_x$ (410 μ s)	$2^{12} \times 1/f_x$ (819 μ s)
0	0	1	$2^{12} \times 1/f_{xx}$	$2^{12} \times 1/f_x$ (819 μ s)	$2^{13} \times 1/f_x$ (1.64 ms)
0	1	0	$2^{13} \times 1/f_{xx}$	$2^{13} \times 1/f_x$ (1.64 ms)	$2^{14} \times 1/f_x$ (3.28 ms)
0	1	1	$2^{14} \times 1/f_{xx}$	$2^{14} \times 1/f_x$ (3.28 ms)	$2^{15} \times 1/f_x$ (6.55 ms)
1	0	0	$2^{15} \times 1/f_{xx}$	$2^{15} \times 1/f_x$ (6.55 ms)	$2^{16} \times 1/f_x$ (13.1 ms)
1	0	1	$2^{16} \times 1/f_{xx}$	$2^{16} \times 1/f_x$ (13.1 ms)	$2^{17} \times 1/f_x$ (26.2 ms)
1	1	0	$2^{17} \times 1/f_{xx}$	$2^{17} \times 1/f_x$ (26.2 ms)	$2^{18} \times 1/f_x$ (52.4 ms)
1	1	1	$2^{19} \times 1/f_{xx}$	$2^{19} \times 1/f_x$ (104.9 ms)	$2^{20} \times 1/f_x$ (209.7 ms)

- Remarks**
1. f_{xx} : Main system clock frequency (f_x or $f_x/2$)
 2. f_x : Main system clock oscillation frequency
 3. MCS : Bit 0 of oscillation mode selection register (OSMS)
 4. TCL20 to TCL22 : Bits 0 to 2 of timer clock select register 2 (TCL2)
 5. Figures in parentheses apply to operation with $f_x = 5.0$ MHz.

11.4.2 Interval timer operation

The watchdog timer operates as an interval timer which generates interrupt requests repeatedly at an interval of the preset count value when bit 4 (WDTM4) of the watchdog timer mode register (WDTM) is set to 0.

A count clock (interval time) can be selected by the bits 0 through 2 (TCL20 through TCL22) of the timer clock select register 2 (TCL2). By setting the bit 7 (RUN) of WDTM to 1, the watchdog timer starts operating as an interval timer.

When the watchdog timer operated as interval timer, the interrupt mask flag (TMMK4) and priority specify flag (TMPR4) are validated and the maskable interrupt request (INTWDT) can be generated. Among maskable interrupt requests, the INTWDT default has the highest priority.

The interval timer continues operating in the HALT mode but it stops in STOP mode. Thus, set bit 7 (RUN) of WDTM to 1 before the STOP mode is set, clear the interval timer and then execute the STOP instruction.

- Cautions**
1. Once bit 4 (WDTM4) of WDTM is set to 1 (with the watchdog timer mode selected), the interval timer mode is not set unless RESET input is applied.
 2. The interval time just after setting with WDTM may be shorter than the set time by a maximum of 0.5 %.
 3. When the subsystem clock is selected for CPU clock, watchdog timer count operation is stopped.

Table 11-5. Interval Timer Interval Time

TCL22	TCL21	TCL20	Interval Time	MCS = 1	MCS = 0
0	0	0	$2^{11} \times 1/f_{xx}$	$2^{11} \times 1/f_x$ (410 μ s)	$2^{12} \times 1/f_x$ (819 μ s)
0	0	1	$2^{12} \times 1/f_{xx}$	$2^{12} \times 1/f_x$ (819 μ s)	$2^{13} \times 1/f_x$ (1.64 ms)
0	1	0	$2^{13} \times 1/f_{xx}$	$2^{13} \times 1/f_x$ (1.64 ms)	$2^{14} \times 1/f_x$ (3.28 ms)
0	1	1	$2^{14} \times 1/f_{xx}$	$2^{14} \times 1/f_x$ (3.28 ms)	$2^{15} \times 1/f_x$ (6.55 ms)
1	0	0	$2^{15} \times 1/f_{xx}$	$2^{15} \times 1/f_x$ (6.55 ms)	$2^{16} \times 1/f_x$ (13.1 ms)
1	0	1	$2^{16} \times 1/f_{xx}$	$2^{16} \times 1/f_x$ (13.1 ms)	$2^{17} \times 1/f_x$ (26.2 ms)
1	1	0	$2^{17} \times 1/f_{xx}$	$2^{17} \times 1/f_x$ (26.2 ms)	$2^{18} \times 1/f_x$ (52.4 ms)
1	1	1	$2^{19} \times 1/f_{xx}$	$2^{19} \times 1/f_x$ (104.9 ms)	$2^{20} \times 1/f_x$ (209.7 ms)

- Remarks**
1. f_{xx} : Main system clock frequency (f_x or $f_x/2$)
 2. f_x : Main system clock oscillation frequency
 3. MCS : Bit 0 of oscillation mode selection register (OSMS)
 4. TCL20 to TCL22 : Bits 0 to 2 of timer clock select register 2 (TCL2)
 5. Figures in parentheses apply to operation with $f_x = 5.0$ MHz.

CHAPTER 12 CLOCK OUTPUT CONTROL CIRCUIT

12.1 Clock Output Control Circuit Functions

The clock output control circuit is intended for carrier output during remote controlled transmission and clock output for supply to peripheral LSI. Clocks selected with the timer clock select register 0 (TCL0) are output from the PCL/P35 pin.

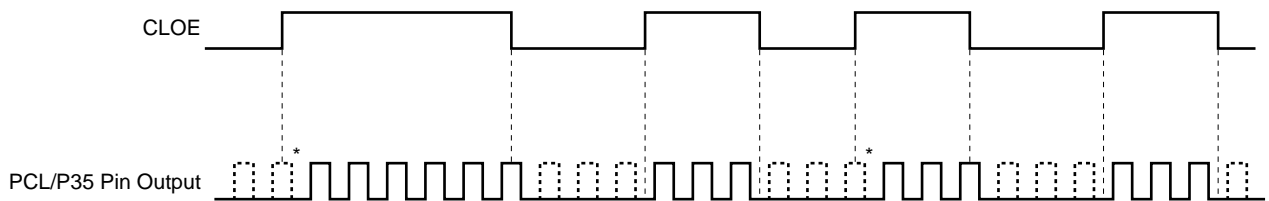
Follow the procedure below to output clock pulses.

- (1) Select the clock pulse output frequency (with clock pulse output disabled) with bits 0 to 3 (TCL00 to TCL03) of TCL0.
- (2) Set the P35 output latch to 0.
- (3) Set bit 5 (PM35) of port mode register 3 (PM3) to 0 (set to output mode).
- (4) Set bit 7 (CLOE) of timer clock select register 0 (TCL0) to 1.

Caution Clock output cannot be used when setting P35 output latch to 1.

Remark When clock output enable/disable is switched, the clock output control circuit does not output pulses with small widths (See the portions marked with * in **Figure 12-1**).

Figure 12-1. Remote Controlled Output Application Example



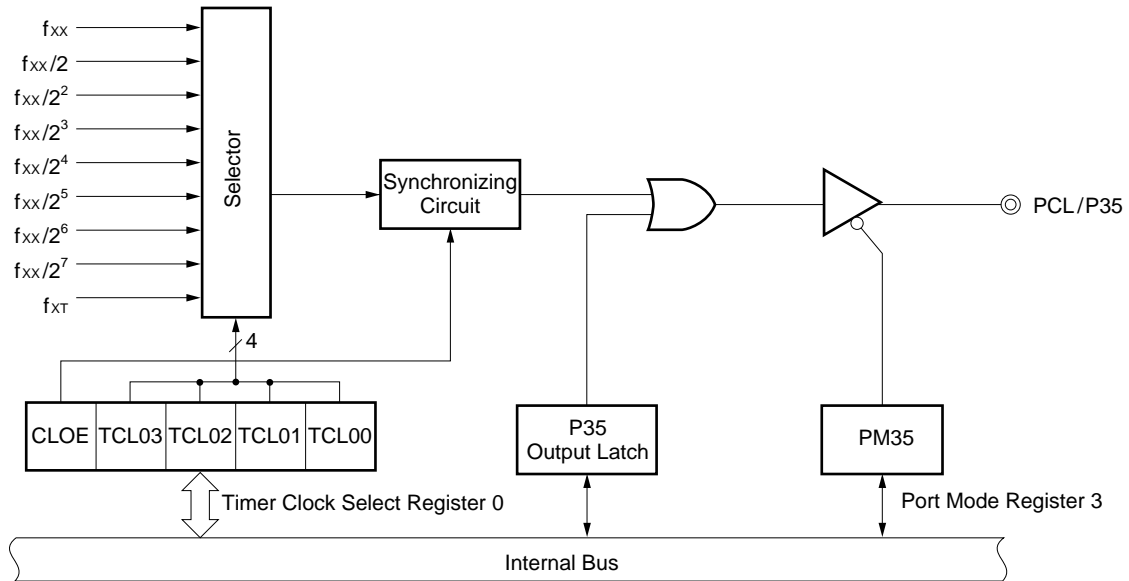
12.2 Clock Output Control Circuit Configuration

The clock output control circuit consists of the following hardware.

Table 12-1. Clock Output Control Circuit Configuration

Item	Configuration
Control register	Timer clock select register 0 (TCL0) Port mode register 3 (PM3)

Figure 12-2. Clock Output Control Circuit Block Diagram



12.3 Clock Output Function Control Registers

The following two types of registers are used to control the clock output function.

- Timer clock select register 0 (TCL0)
- Port mode register 3 (PM3)

(1) Timer clock select register 0 (TCL0)

This register sets PCL output clock.

TCL0 is set with a 1-bit or 8-bit memory manipulation instruction.

RESET input sets TCL0 to 00H.

Remark Besides setting PCL output clock, TCL0 sets the 16-bit timer register count clock.

Figure 12-3. Timer Clock Select Register 0 Format

Symbol	<7>	6	5	4	3	2	1	0	Address	After Reset	R/W
TCL0	CLOE	TCL06	TCL05	TCL04	TCL03	TCL02	TCL01	TCL00	FF40H	00H	R/W

TCL03				TCL02				TCL01				TCL00				PCL Output Clock Selection		
												MCS = 1			MCS = 0			
0	0	0	0	0	0	0	0	f_{XT} (32.768 kHz)										
0	1	0	1	f_{XX}			f_x (5.0 MHz)			$f_x/2$ (2.5 MHz)								
0	1	1	0	$f_{XX}/2$			$f_x/2$ (2.5 MHz)			$f_x/2^2$ (1.25 MHz)								
0	1	1	1	$f_{XX}/2^2$			$f_x/2^2$ (1.25 MHz)			$f_x/2^3$ (625 kHz)								
1	0	0	0	$f_{XX}/2^3$			$f_x/2^3$ (625 kHz)			$f_x/2^4$ (313 kHz)								
1	0	0	1	$f_{XX}/2^4$			$f_x/2^4$ (313 kHz)			$f_x/2^5$ (156 kHz)								
1	0	1	0	$f_{XX}/2^5$			$f_x/2^5$ (156 kHz)			$f_x/2^6$ (78.1 kHz)								
1	0	1	1	$f_{XX}/2^6$			$f_x/2^6$ (78.1 kHz)			$f_x/2^7$ (39.1 kHz)								
1	1	0	0	$f_{XX}/2^7$			$f_x/2^7$ (39.1 kHz)			$f_x/2^8$ (19.5 kHz)								
Other than above				Setting prohibited														

TCL06			TCL05			TCL04			16-Bit Timer Register Count Clock Selection					
									MCS = 1			MCS = 0		
0	0	0	TI00 (Valid edge specifiable)											
0	0	1	$2f_{XX}$			Setting prohibited			f_x (5.0 MHz)					
0	1	0	f_{XX}			f_x (5.0 MHz)			$f_x/2$ (2.5 MHz)					
0	1	1	$f_{XX}/2$			$f_x/2$ (2.5 MHz)			$f_x/2^2$ (1.25 MHz)					
1	0	0	$f_{XX}/2^2$			$f_x/2^2$ (1.25 MHz)			$f_x/2^3$ (625 kHz)					
1	1	1	Watch Timer Output (INTTM3)											
Other than above			Setting prohibited											

CLOE	PCL Output Control
0	Output disable
1	Output enable

- Cautions**
1. Set the TI00/P00/INTP0 pin valid edge by external interrupt mode register 0 (INTM0), and select the sampling clock frequency by the sampling clock selection register (SCS).
 2. When enabling PCL output, set TCL00 to TCL03, then set 1 in CLOE with a 1-bit memory manipulation instruction.
 3. To read the count value when TI00 has been specified as the TM0 count clock, the value should be read from TM0, not from 16-bit capture/compare register 01 (CR01).
 4. When rewriting TCL0 to other data, stop the clock operation beforehand.

- Remarks**
1. f_{xx} : Main system clock frequency (f_x or $f_x/2$)
 2. f_x : Main system clock oscillation frequency
 3. f_{xT} : Subsystem clock oscillation frequency
 4. TI00 : 16-bit timer/event counter input pin
 5. TM0 : 16-bit timer register
 6. MCS : Oscillation mode selection register (OSMS) bit 0
 7. Figures in parentheses apply to operation with $f_x = 5.0$ MHz or $f_{xT} = 32.768$ kHz.

(2) Port mode register 3 (PM3)

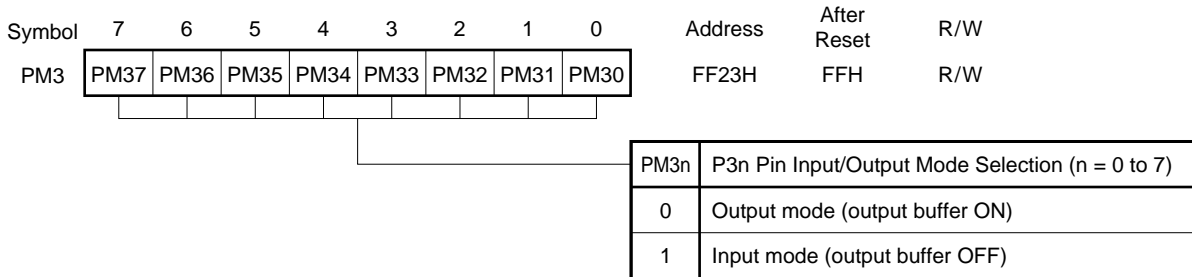
This register set port 3 input/output in 1-bit units.

When using the P35/PCL pin for clock output function, set PM35 and output latch of P35 to 0.

PM3 is set with a 1-bit or 8-bit memory manipulation instruction.

$\overline{\text{RESET}}$ input sets PM3 to FFH.

Figure 12-4. Port Mode Register 3 Format



[MEMO]

CHAPTER 13 BUZZER OUTPUT CONTROL CIRCUIT

13.1 Buzzer Output Control Circuit Functions

The buzzer output control circuit outputs 1.2 kHz, 2.4 kHz, 4.9 kHz, or 9.8 kHz frequency square waves. The buzzer frequency selected with timer clock select register 2 (TCL2) is output from the BUZ/P36 pin.

Follow the procedure below to output the buzzer frequency.

- (1) Select the buzzer output frequency with bits 5 to 7 (TCL25 to TCL27) of TCL2.
- (2) Set the P36 output latch to 0.
- (3) Set bit 6 (PM36) of port mode register 3 (PM3) to 0 (Set to output mode).

Caution Buzzer output cannot be used when setting P36 output latch to 1.

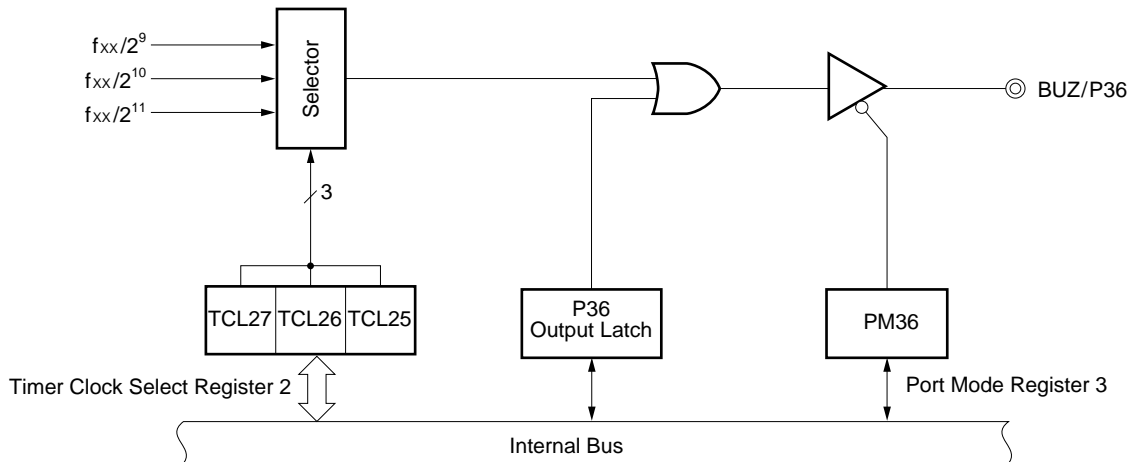
13.2 Buzzer Output Control Circuit Configuration

The buzzer output control circuit consists of the following hardware.

Table 13-1. Buzzer Output Control Circuit Configuration

Item	Configuration
Control register	Timer clock select register 2 (TCL2) Port mode register 3 (PM3)

Figure 13-1. Buzzer Output Control Circuit Block Diagram



13.3 Buzzer Output Function Control Registers

The following two types of registers are used to control the buzzer output function.

- Timer clock select register 2 (TCL2)
- Port mode register 3 (PM3)

(1) Timer clock select register 2 (TCL2)

This register sets the buzzer output frequency.

TCL2 is set with an 8-bit memory manipulation instruction.

RESET input sets TCL2 to 00H.

Remark Besides setting the buzzer output frequency, TCL2 sets the watch timer count clock and the watchdog timer count clock.

Figure 13-2. Timer Clock Select Register 2 Format

Symbol	7	6	5	4	3	2	1	0	Address	After Reset	R/W
TCL2	TCL27	TCL26	TCL25	TCL24	0	TCL22	TCL21	TCL20	FF42H	00H	R/W

TCL22	TCL21	TCL20	Watchdog Timer Count Clock Selection		
				MCS = 1	MCS = 0
0	0	0	$f_{xx}/2^3$	$f_x/2^3$ (625 kHz)	$f_x/2^4$ (313 kHz)
0	0	1	$f_{xx}/2^4$	$f_x/2^4$ (313 kHz)	$f_x/2^5$ (156 kHz)
0	1	0	$f_{xx}/2^5$	$f_x/2^5$ (156 kHz)	$f_x/2^6$ (78.1 kHz)
0	1	1	$f_{xx}/2^6$	$f_x/2^6$ (78.1 kHz)	$f_x/2^7$ (39.1 kHz)
1	0	0	$f_{xx}/2^7$	$f_x/2^7$ (39.1 kHz)	$f_x/2^8$ (19.5 kHz)
1	0	1	$f_{xx}/2^8$	$f_x/2^8$ (19.5 kHz)	$f_x/2^9$ (9.8 kHz)
1	1	0	$f_{xx}/2^9$	$f_x/2^9$ (9.8 kHz)	$f_x/2^{10}$ (4.9 kHz)
1	1	1	$f_{xx}/2^{11}$	$f_x/2^{11}$ (2.4 kHz)	$f_x/2^{12}$ (1.2 kHz)

TCL24	Watchdog Timer Count Clock Selection		
		MCS = 1	MCS = 0
0	$f_{xx}/2^7$	$f_x/2^7$ (39.1 kHz)	$f_x/2^8$ (19.5 kHz)
1	f_{XT} (32.768 kHz)		

TCL27	TCL26	TCL25	Buzzer Output Frequency Selection		
				MCS = 1	MCS = 0
0	×	×	Buzzer output disable		
1	0	0	$f_{xx}/2^9$	$f_x/2^9$ (9.8 kHz)	$f_x/2^{10}$ (4.9 kHz)
1	0	1	$f_{xx}/2^{10}$	$f_x/2^{10}$ (4.9 kHz)	$f_x/2^{11}$ (2.4 kHz)
1	1	0	$f_{xx}/2^{11}$	$f_x/2^{11}$ (2.4 kHz)	$f_x/2^{12}$ (1.2 kHz)
1	1	1	Setting prohibited		

Caution When rewriting TCL2 to other data, stop the timer operation beforehand.

- Remarks**
1. f_{xx} : Main system clock frequency (f_x or $f_x/2$)
 2. f_x : Main system clock oscillation frequency
 3. f_{XT} : Subsystem clock oscillation frequency
 4. × : don't care
 5. MCS : Bit 0 of oscillation mode selection register (OSMS)
 6. Figures in parentheses apply to operation with $f_x = 5.0$ MHz or $f_{XT} = 32.768$ kHz.

(2) Port mode register 3 (PM3)

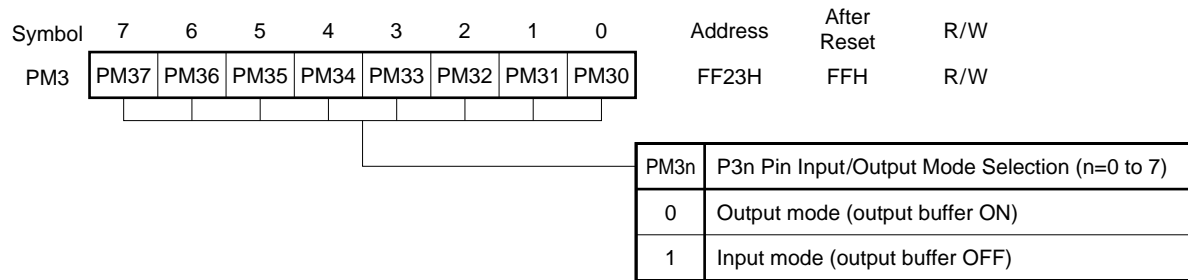
This register sets port 3 input/output in 1-bit units.

When using the P36/BUZ pin for buzzer output function, set PM36 and output latch of P36 to 0.

PM3 is set with a 1-bit or 8-bit memory manipulation instruction.

RESET input sets PM3 to FFH.

Figure 13-3. Port Mode Register 3 Format



CHAPTER 14 A/D CONVERTER

14.1 A/D Converter Functions

The A/D converter converts an analog input into a digital value. It consists of 8 channels (ANI0 to ANI7) with an 8-bit resolution.

The conversion method is based on successive approximation and the conversion result is held in the 8-bit A/D conversion result register (ADCR).

The following two ways are available to start A/D conversion.

(1) Hardware start

Conversion is started by trigger input (INTP3).

(2) Software start

Conversion is started by setting the A/D converter mode register (ADM).

Select one channel of analog input from ANI0 to ANI7 and perform A/D conversion. In the case of hardware start, A/D conversion operation stops when an A/D conversion ends, and an interrupt request (INTAD) is generated. In the case of software start, the A/D conversion operation is repeated. Each time an A/D conversion operation ends, an interrupt request (INTAD) is generated.

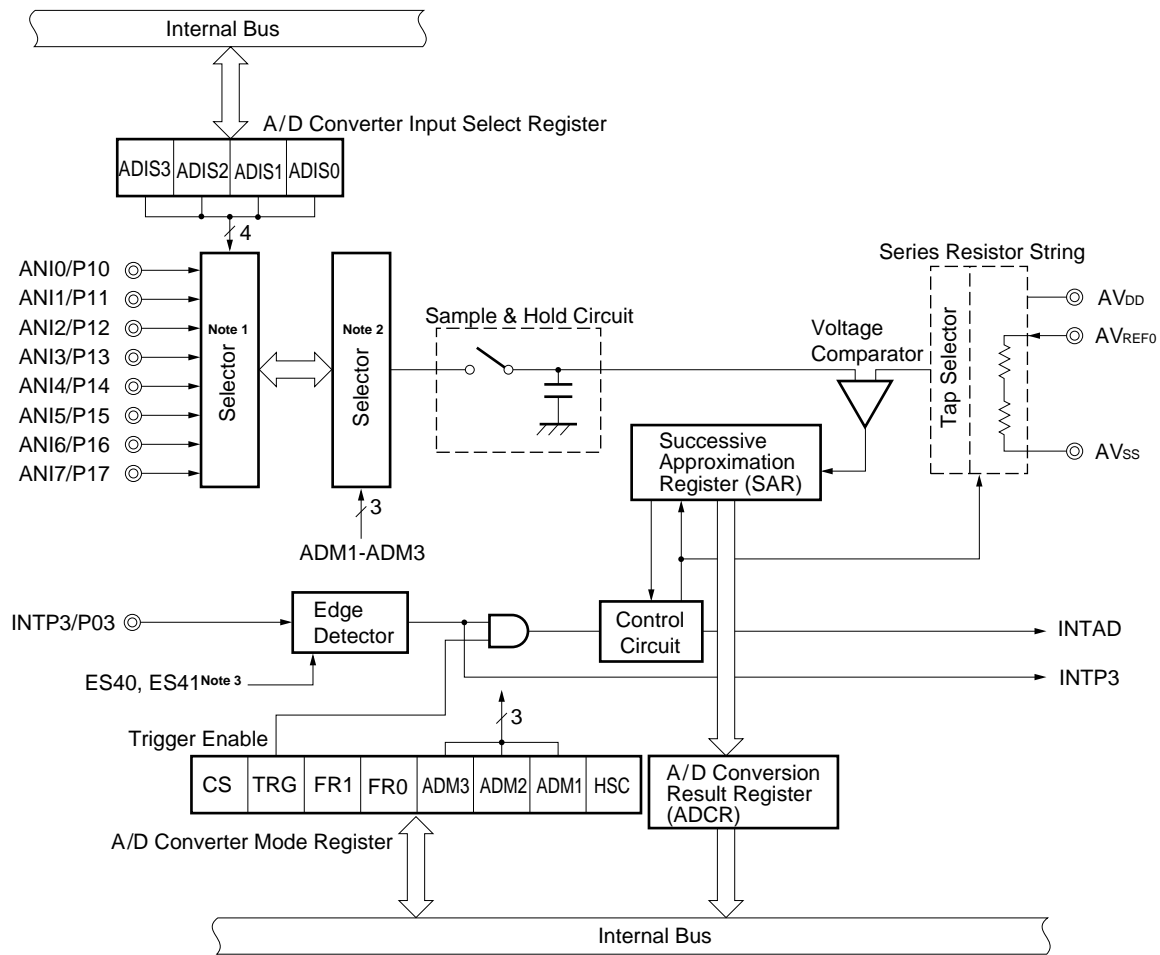
14.2 A/D Converter Configuration

The A/D converter consists of the following hardware.

Table 14-1. A/D Converter Configuration

Item	Configuration
Analog input	8 Channels (ANI0 to ANI7)
Control register	A/D converter mode register (ADM) A/D converter input select register (ADIS) External interrupt mode register 1 (INTM1)
Register	Successive approximation register (SAR) A/D conversion result register (ADCR)

Figure 14-1. A/D Converter Block Diagram



- Notes**
1. Selector to select the number of channels to be used for analog input.
 2. Selector to select the channel for A/D conversion.
 3. Bits 0 and 1 of external interrupt mode register 1 (INTM1)

(1) Successive approximation register (SAR)

This register compares the analog input voltage value to the voltage tap (compare voltage) value applied from the series resistor string and holds the result from the most significant bit (MSB).

When up to the least significant bit (LSB) is held (termination of A/D conversion), the SAR contents are transferred to the A/D conversion result register (ADCR).

(2) A/D conversion result register (ADCR)

This register holds the A/D conversion result. Each time A/D conversion terminates, the conversion result is loaded from the successive approximation register (SAR).

ADCR is read with an 8-bit memory manipulation instruction.

$\overline{\text{RESET}}$ input makes ADCR undefined.

(3) Sample & hold circuit

The sample & hold circuit samples each analog input signal sequentially applied from the input circuit and sends it to the voltage comparator. This circuit holds the sampled analog input voltage value during A/D conversion.

(4) Voltage comparator

The voltage comparator compares the analog input to the series resistor string output voltage.

(5) Series resistor string

The series resistor string is connected between AV_{REF0} and AV_{SS} and generates a voltage to be compared to the analog input.

(6) ANI0 to ANI7 pins

These are 8-channel analog input pins to input analog signals to undergo A/D conversion to the A/D converter. Pins other than those selected as analog input by the A/D converter input select register (ADIS) can be used as input/output ports.

- Cautions**
- 1. Use ANI0 to ANI7 input voltages within the specified range. If a voltage higher than AV_{REF0} or lower than AV_{SS} is applied (even if within the absolute maximum ratings), the converted value of the corresponding channel becomes indeterminate and may adversely affect the converted values of other channels.**
 - 2. Analog input (ANI0 to ANI7) pins are multiplexed with the input/output port (port 1). When performing A/D conversion with one of ANI0 to ANI7 selected, do not execute an input instruction to port 1 during conversion. Otherwise, the conversion resolution may be deteriorated. In addition, if a digital pulse is applied to a pin adjacent to the pin performing A/D conversion, the desired A/D conversion value may not be obtained due to coupling noise. Therefore, do not apply a pulse to a pin adjacent to the pin performing A/D conversion.**

(7) AV_{REF0} pin

This pin inputs the A/D converter reference voltage.

It converts signals input to ANI0 to ANI7 into digital signals according to the voltage applied between AV_{REF0} and AV_{SS}.

The current flowing in the series resistor string can be reduced by setting the voltage to be input to the AV_{REF0} pin to AV_{SS} level in standby mode.

Caution A serial resistor string of approximately 10 k Ω is connected between the AV_{REF0} pin and the AV_{SS} pin. Therefore, when the output impedance of the reference voltage is high, it is connected in parallel to the serial resistor string between the AV_{REF0} pin and the AV_{SS} pin so that the reference voltage error increases.

(8) AV_{SS} pin

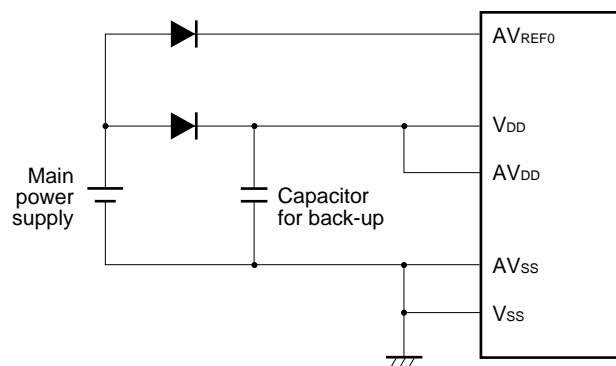
This is a GND potential pin of the A/D converter. Keep it at the same potential as the V_{SS} pin when not using the A/D converter.

(9) AV_{DD} pin

This is an A/D converter analog power supply pin. Keep it at the same potential as the V_{SS} pin when not using the A/D converter.

Caution AV_{DD} pin is the power supply pin of the analog circuit, and it supplies power also to the input circuit of ANI0/P10 to ANI7/P17. Therefore, always supply the voltage of the same level as V_{DD} as shown in Figure 14-2 also in applications which switch to backup power supply.

Figure 14-2. Handling of AV_{DD} Pin



14.3 A/D Converter Control Registers

The following three types of registers are used to control the A/D converter.

- A/D converter mode register (ADM)
- A/D converter input select register (ADIS)
- External interrupt mode register 1 (INTM1)

(1) A/D converter mode register (ADM)

This register sets the analog input channel for A/D conversion, conversion time, conversion start/stop and external trigger.

ADM is set with a 1-bit or 8-bit memory manipulation instruction.

$\overline{\text{RESET}}$ input sets ADM to 01H.

Figure 14-3. A/D Converter Mode Register Format

Symbol	<7>	<6>	5	4	3	2	1	0	Address	After Reset	R/W
ADM	CS	TRG	FR1	FR0	ADM3	ADM2	ADM1	HSC	FF80H	01H	R/W

ADM3	ADM2	ADM1	Analog Input Channel Selection
0	0	0	ANI0
0	0	1	ANI1
0	1	0	ANI2
0	1	1	ANI3
1	0	0	ANI4
1	0	1	ANI5
1	1	0	ANI6
1	1	1	ANI7

FR1	FR0	HSC	A/D Conversion Time Selection ^{Note 1}			
			fx = 5.0 MHz Operation		fx = 4.19 MHz Operation	
			MCS = 1	MCS = 0	MCS = 1	MCS = 0
0	0	1	80/fx (Setting prohibited ^{Note 2})	160/fx (32.0μs)	80/fx (19.1μs)	160/fx (38.1μs)
0	1	1	40/fx (Setting prohibited ^{Note 2})	80/fx (Setting prohibited ^{Note 2})	40/fx (Setting prohibited ^{Note 2})	80/fx (19.1μs)
1	0	0	50/fx (Setting prohibited ^{Note 2})	100/fx (20.0μs)	50/fx (Setting prohibited ^{Note 2})	100/fx (23.8μs)
1	0	1	100/fx (20.0μs)	200/fx (40.0μs)	100/fx (23.8μs)	200/fx (47.7μs)
Other than above		Setting prohibited				

TRG	External Trigger Selection
0	No external trigger (software starts)
1	Conversion started by external trigger (hardware starts)

CS	A/D Conversion Operation Control
0	Operation stop
1	Operation start

- Notes**
1. Set so that the A/D conversion time is 19.1 μs or more.
 2. Setting prohibited because A/D conversion time is less than 19.1 μs.

- Cautions**
1. The following sequence is recommended for power consumption reduction of A/D converter when the standby function is used: Clear bit 7 (CS) to 0 first to stop the A/D conversion operation, and then execute the HALT or STOP instruction.
 2. When restarting the stopped A/D conversion operation, start the A/D conversion operation after clearing the interrupt request flag (ADIF) to 0.

- Remarks**
1. fx : Main system clock oscillation frequency
 2. MCS : Bit 0 of oscillation mode selection register (OSMS)

(2) A/D converter input select register (ADIS)

This register determines whether the ANI0/P10 to ANI7/P17 pins should be used for analog input channels or ports. Pins other than those selected as analog input can be used as input/output ports.

ADIS is set with an 8-bit memory manipulation instruction.

RESET input sets ADIS to 00H.

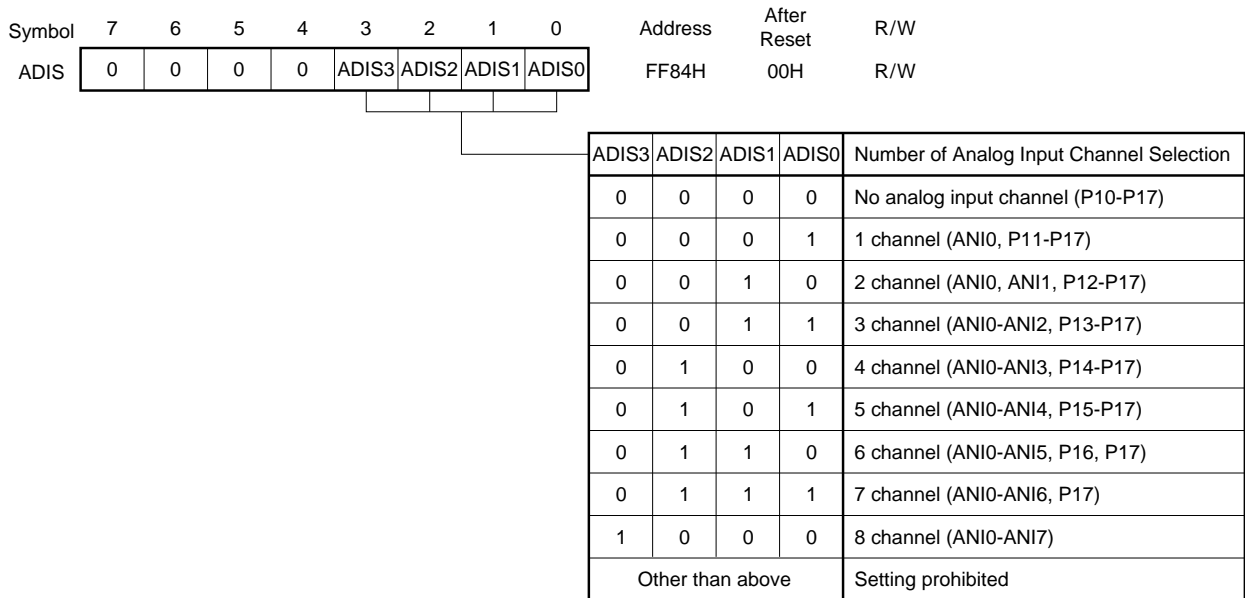
Cautions 1. Set the analog input channel in the following order.

(1) Set the number of analog input channels with ADIS.

(2) Using A/D converter mode register (ADM), select one channel to undergo A/D conversion from among the channels set for analog input with ADIS.

2. No internal pull-up resistor can be used to the channels set for analog input with ADIS, irrespective of the value of bit 1 (PUO1) of the pull-up resistor option register L (PUOL).

Figure 14-4. A/D Converter Input Select Register Format



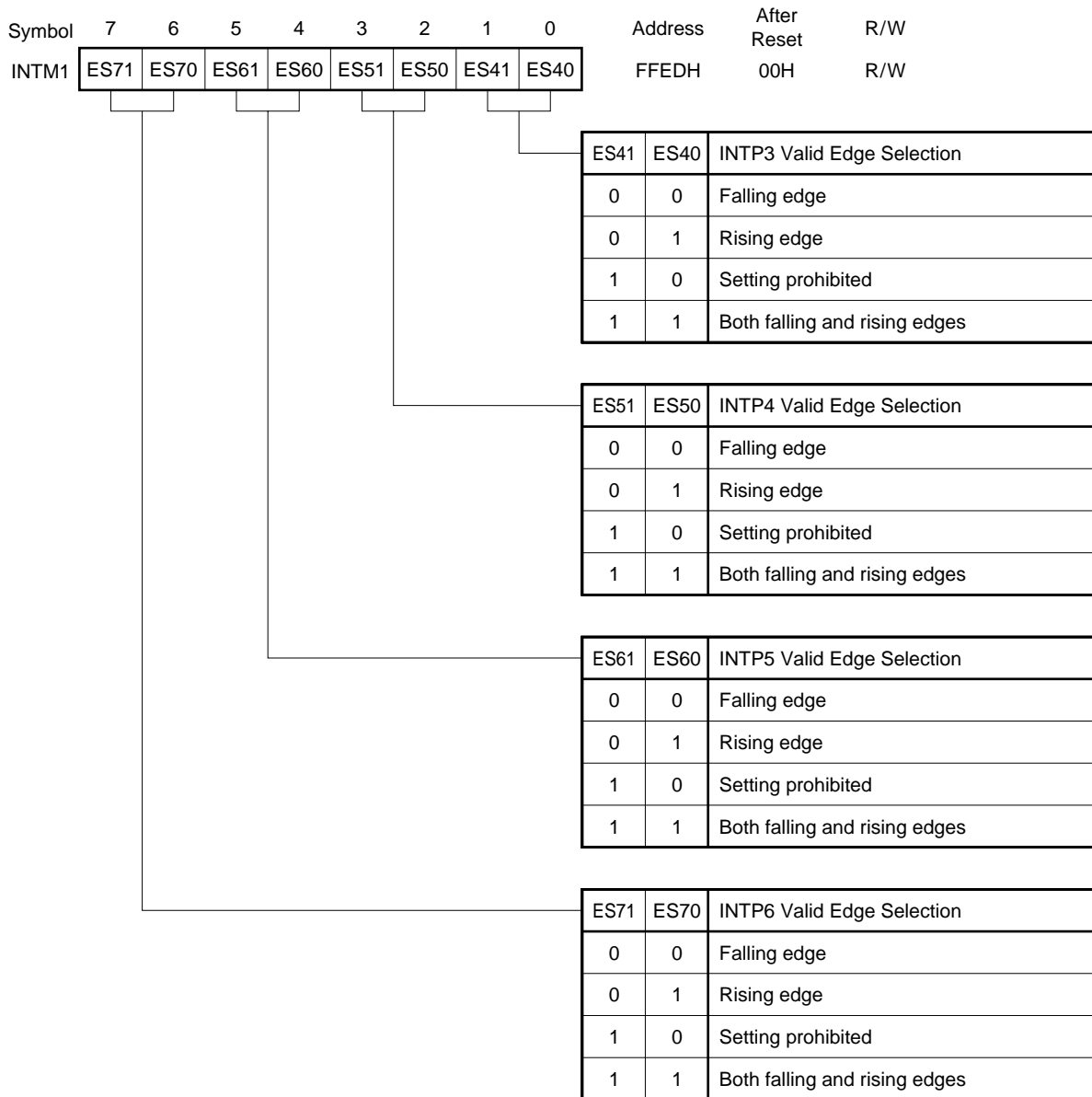
(3) External interrupt mode register 1 (INTM1)

This register sets the valid edge for INTP3 to INTP6.

INTM1 is set with an 8-bit memory manipulation instruction.

$\overline{\text{RESET}}$ input sets INTM1 to 00H.

Figure 14-5. External Interrupt Mode Register 1 Format



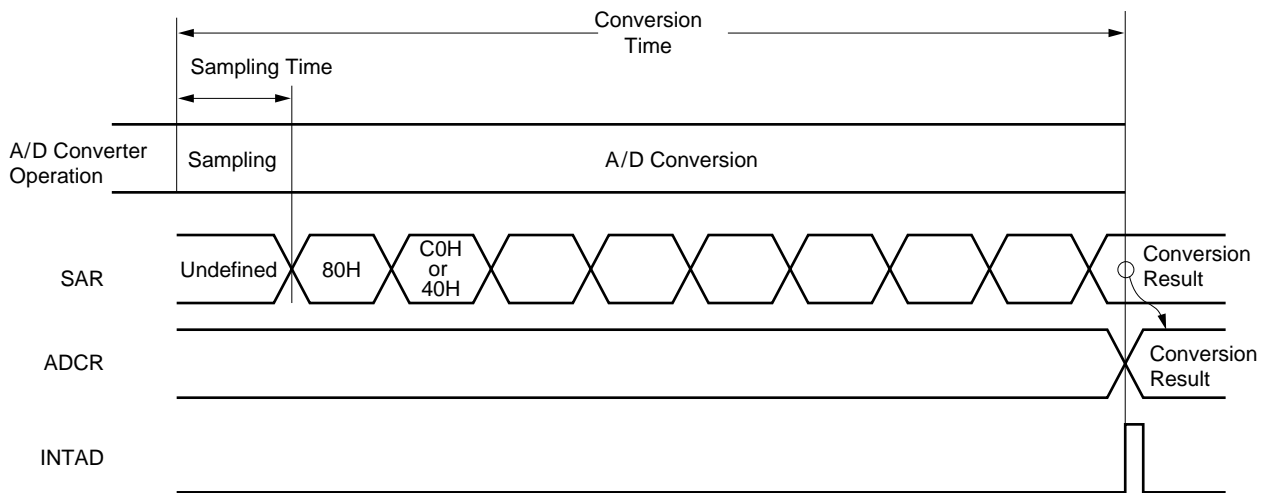
14.4 A/D Converter Operations

14.4.1 Basic operations of A/D converter

- (1) Set the number of analog input channels with A/D converter input select register (ADIS).
- (2) From among the analog input channels set with ADIS, select one channel for A/D conversion with A/D converter mode register (ADM).
- (3) Sample & hold circuit samples the voltage input to the selected analog input channel.
- (4) Sampling for the specified period of time sets the sample & hold circuit to the hold state so that the circuit holds the input analog voltage until termination of A/D conversion.
- (5) Bit 7 of the successive approximation register (SAR) is set and the tap selector sets the series resistor string voltage tap to $(1/2) AV_{REF0}$.
- (6) The voltage difference between the series resistor string voltage tap and analog input is compared with a voltage comparator. If the analog input is greater than $(1/2) AV_{REF0}$, the MSB of SAR remains set. If the input is smaller than $(1/2) AV_{REF0}$, the MSB is reset.
- (7) Next, bit 6 of SAR is automatically set and the operation proceeds to the next comparison. In this case, the series resistor string voltage tap is selected according to the preset value of bit 7 as described below.
 - Bit 7 = 1 : $(3/4) AV_{REF0}$
 - Bit 7 = 0 : $(1/4) AV_{REF0}$The voltage tap and analog input voltage are compared and bit 6 of SAR is manipulated with the result as follows.
 - Analog input voltage \geq Voltage tap : Bit 6 = 1
 - Analog input voltage $<$ Voltage tap : Bit 6 = 0
- (8) Comparison of this sort continues up to bit 0 of SAR.
- (9) Upon completion of the comparison of 8 bits, any effective digital resultant value remains in SAR and the resultant value is transferred to and latched in the A/D conversion result register (ADCR).

At the same time, the A/D conversion termination interrupt request (INTAD) can also be generated.

Figure 14-6. A/D Converter Basic Operation



A/D conversion operations are performed continuously until bit 7 (CS) of ADM is reset (0) by software.

If a write to the ADM is performed during an A/D conversion operation, the conversion operation is initialized, and if the CS bit is set (1), conversion starts again from the beginning.

After RESET input, the value of ADCR is undefined.

14.4.2 Input voltage and conversion results

The relation between the analog input voltage input to the analog input pins (ANI0 to ANI7) and the A/D conversion result (the value stored in A/D conversion result register (ADCR)) is shown by the following expression.

$$ADCR = \text{INT} \left(\frac{V_{IN}}{AV_{REF0}} \times 256 + 0.5 \right)$$

or

$$(ADCR - 0.5) \times \frac{AV_{REF0}}{256} \leq V_{IN} < (ADCR + 0.5) \times \frac{AV_{REF0}}{256}$$

Where, INT () : Function which returns integer parts of value in parentheses.

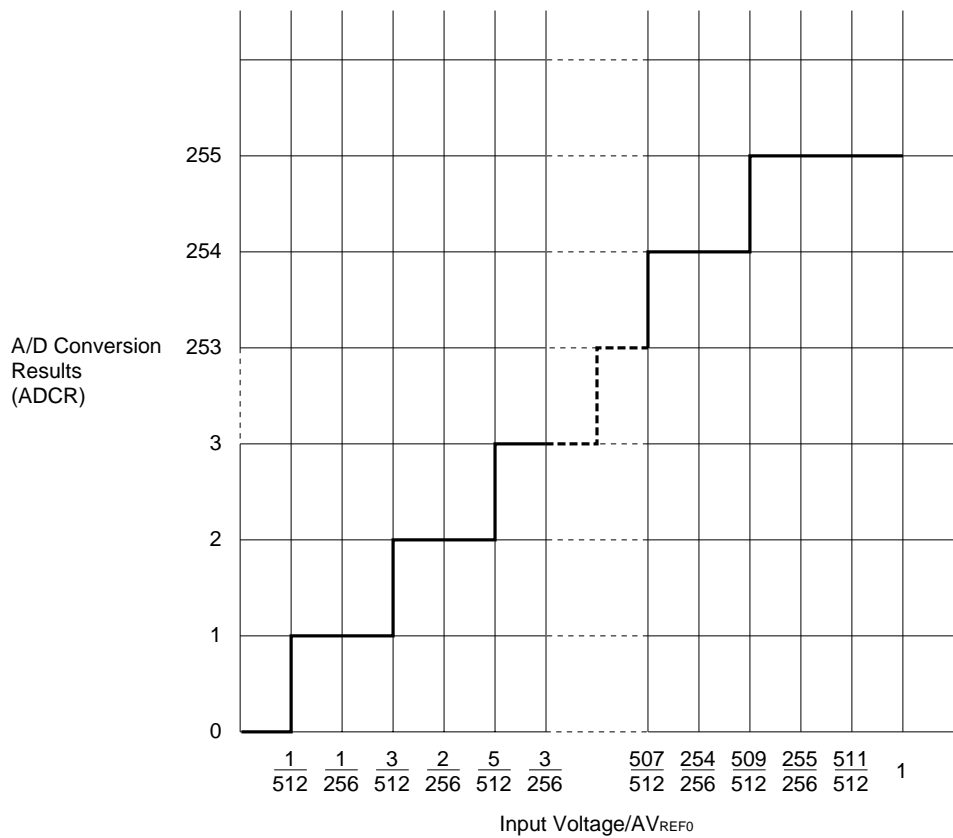
V_{IN} : Analog input voltage

AV_{REF0} : AV_{REF0} pin voltage

ADCR : Value of A/D conversion result register (ADCR)

Figure 14-7 shows the relation between the analog input voltage and the A/D conversion result.

Figure 14-7. Relations between Analog Input Voltage and A/D Conversion Result



14.4.3 A/D converter operating mode

Select one analog input channel from ANI0 to ANI7 with A/D converter input select register (ADIS) and A/D converter mode register (ADM), and start A/D conversion.

The following two ways are available to start A/D conversion.

- Hardware start: Conversion is started by trigger input (INTP3).
- Software start: Conversion is started by setting ADM.

The A/D conversion result is stored in the A/D conversion result register (ADCR) and the interrupt request signal (INTAD) is simultaneously generated.

(1) A/D conversion by hardware start

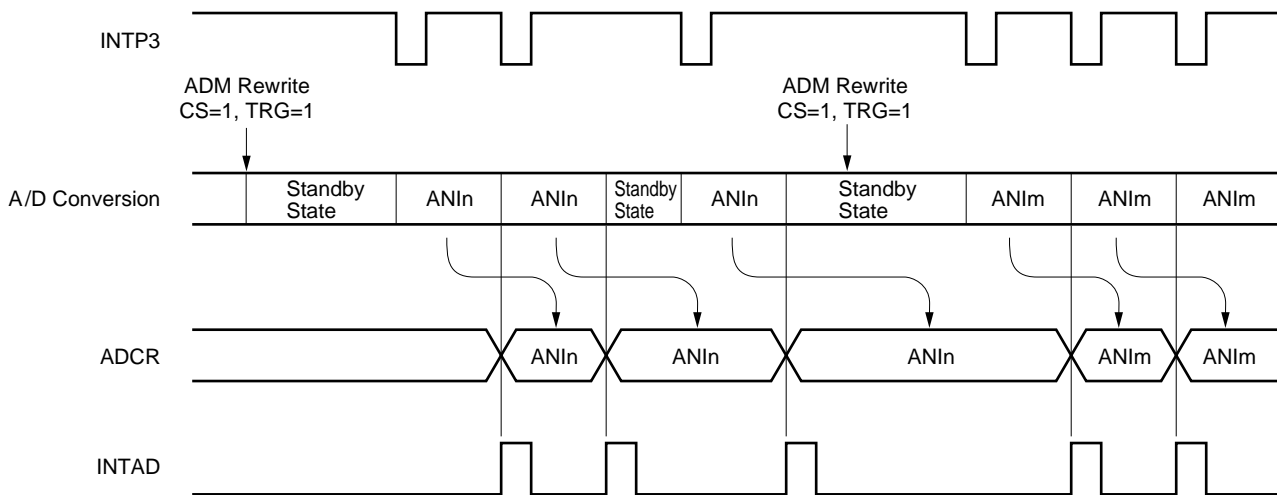
When bit 6 (TRG) and bit 7 (CS) of A/D converter mode register (ADM) are set to 1, the A/D conversion standby state is set. When the external trigger signal (INTP3) is input, the A/D conversion starts on the voltage applied to the analog input pins specified with bits 1 to 3 (ADM1 to ADM3) of ADM.

Upon termination of the A/D conversion, the conversion result is stored in the A/D conversion result register (ADCR) and the interrupt request signal (INTAD) is generated. After one A/D conversion operation is started and terminated, another operation is not started until a new external trigger signal is input.

If data with CS set to 1 is written to ADM again during A/D conversion, the converter suspends its A/D conversion operation and waits for a new external trigger signal to be input. When the external trigger input signal is reinput, A/D conversion is carried out from the beginning.

If data with CS set to 0 is written to ADM during A/D conversion, the A/D conversion operation stops immediately.

Figure 14-8. A/D Conversion by Hardware Start



- Remarks**
1. $n = 0, 1, \dots, 7$
 2. $m = 0, 1, \dots, 7$

(2) A/D conversion operation in software start

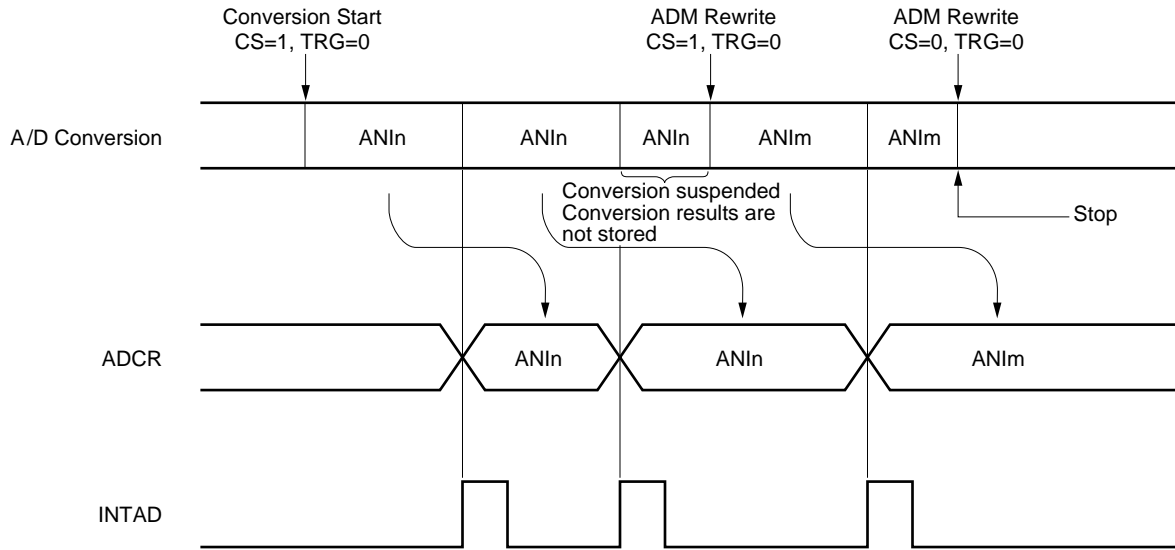
When bit 6 (TRG) and bit 7 (CS) of A/D converter mode register (ADM) are set to 0 and 1, respectively, the A/D conversion starts on the voltage applied to the analog input pins specified with bits 1 to 3 (ADM1 to ADM3) of ADM.

Upon termination of the A/D conversion, the conversion result is stored in the A/D conversion result register (ADCR) and the interrupt request signal (INTAD) is generated. After one A/D conversion operation is started and terminated, the next A/D conversion operation starts immediately. The A/D conversion operation continues repeatedly until new data is written to ADM.

If data with CS set to 1 is written to ADM again during A/D conversion, the converter suspends its A/D conversion operation and starts A/D conversion on the newly written data.

If data with CS set to 0 is written to ADM during A/D conversion, the A/D conversion operation stops immediately.

Figure 14-9. A/D Conversion by Software Start



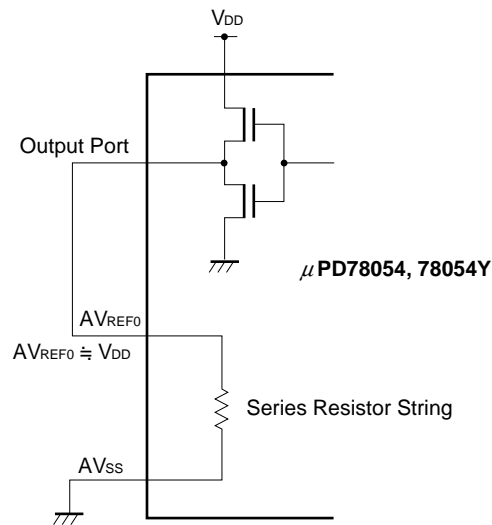
- Remarks**
1. $n = 0, 1, \dots, 7$
 2. $m = 0, 1, \dots, 7$

14.5 A/D Converter Cautions

(1) Power consumption in standby mode

The A/D converter operates on the main system clock. Therefore, its operation stops in STOP mode or in HALT mode with the subsystem clock. As a current still flows in the AV_{REF0} pin at this time, this current must be cut in order to minimize the overall system power dissipation. In Figure 14-10, the power dissipation can be reduced by outputting a low-level signal to the output port in standby mode. However, there is no precision to the actual AV_{REF0} voltage, and therefore the conversion values themselves lack precision and can only be used for relative comparison.

Figure 14-10. Example of Method of Reducing Current Dissipation in Standby Mode



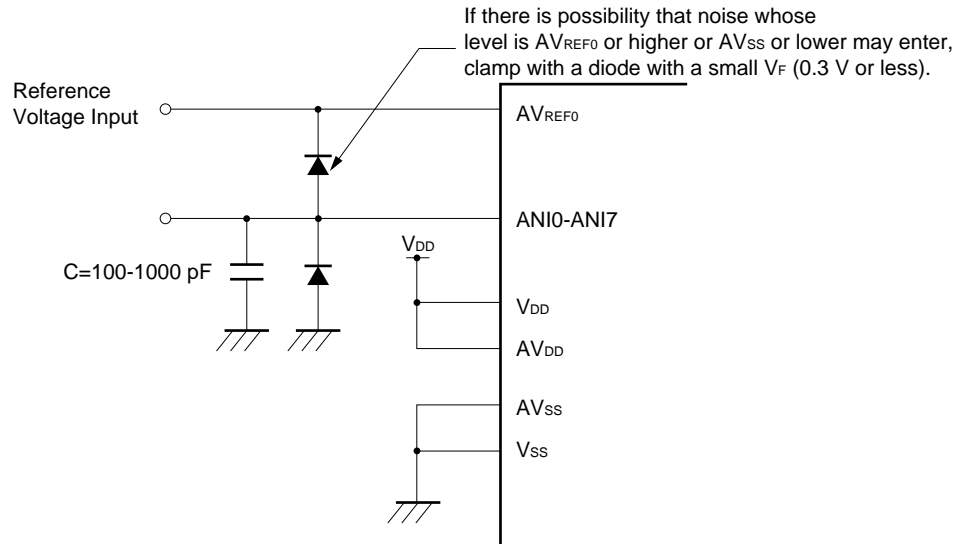
(2) Input range of ANI0 to ANI7

The input voltages of ANI0 to ANI7 should be within the specification range. In particular, if a voltage above AV_{REF0} or below AV_{SS} is input (even if within the absolute maximum rating range), the conversion value for that channel will be indeterminate. The conversion values of the other channels may also be affected.

(3) Noise countermeasures

In order to maintain 8-bit resolution, attention must be paid to noise on pins AV_{REF0} and ANI0 to ANI7. Since the effect increases in proportion to the output impedance of the analog input source, it is recommended that a capacitor be connected externally as shown in Figure 14-11 in order to reduce noise.

Figure 14-11. Analog Input Pin Disposition

**(4) Pins ANI0/P10 to ANI7/P17**

The analog input pins ANI0 to ANI7 also function as input/output port (PORT1) pins.

When A/D conversion is performed with any of pins ANI0 to ANI7 selected, be sure not to execute an input instruction to PORT1 while conversion is in progress, as this may reduce the conversion resolution.

Also, if digital pulses are applied to a pin adjacent to the pin in the process of A/D conversion, the expected A/D conversion value may not be obtainable due to coupling noise. Therefore, avoid applying pulses to pins adjacent to the pin undergoing A/D conversion.

(5) AV_{REF0} pin input impedance

A series resistor string of approximately $10\text{ k}\Omega$ is connected between the AV_{REF0} pin and the AV_{SS} pin.

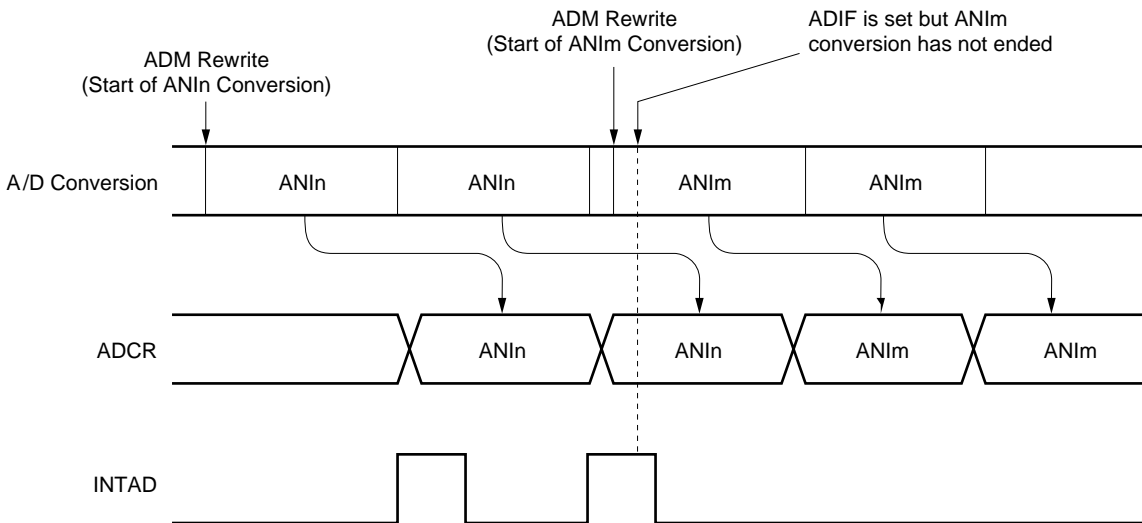
Therefore, if the output impedance of the reference voltage source is high, this will result in parallel connection to the series resistor string between the AV_{REF0} pin and the AV_{SS} pin, and there will be a large reference voltage error.

(6) Interrupt request flag (ADIF)

The interrupt request flag (ADIF) is not cleared even if the A/D converter mode register (ADM) is changed. If an analog input pin is changed during A/D conversion, the A/D conversion result and ADIF for the pre-change analog input may have been set immediately before the ADM rewrite. In this case, if ADIF is read immediately after the ADM rewrite, ADIF may be set despite the fact that the A/D conversion for the post-change analog input has not ended.

When the A/D conversion is stopped and then resumed, clear the ADIF before it is resumed.

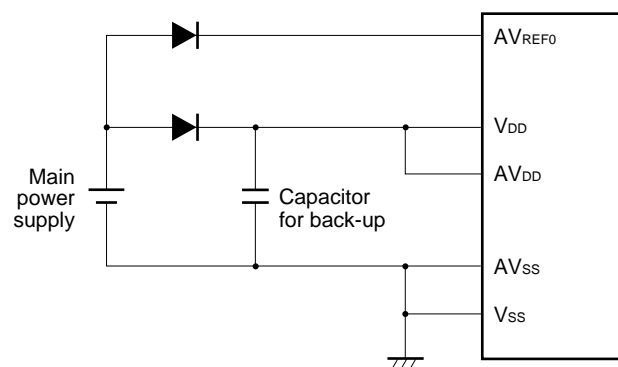
Figure 14-12. A/D Conversion End Interrupt Request Generation Timing

**(7) AV_{DD} pin**

The AV_{DD} pin is the analog circuit power supply pin, and supplies power to the input circuits of ANI0/P10 to ANI7/P17.

Therefore, be sure to apply the same voltage as V_{DD} to this pin even when the application circuit is designed so as to switch to a backup battery as shown in Figure 14-13.

Figure 14-13. Handling of AV_{DD} Pin



CHAPTER 15 D/A CONVERTER

15.1 D/A Converter Functions

The D/A converter converts a digital input into an analog value. It consists of two 8-bit resolution channels of voltage output type D/A converter.

The conversion method used is the R-2R resistor ladder method.

Start the A/D conversion by setting the DACE0 and DACE1 of the D/A converter mode register (DAM).

There are two types of modes for the D/A converter, as follows.

(1) Normal mode

Outputs an analog voltage signal immediately after the D/A conversion.

(2) Real-time output mode

Outputs an analog voltage signal synchronously with the output trigger after the D/A conversion.

Since a sine wave can be generated in the mode, it is useful for an MSK modem for cordless telephone sets.

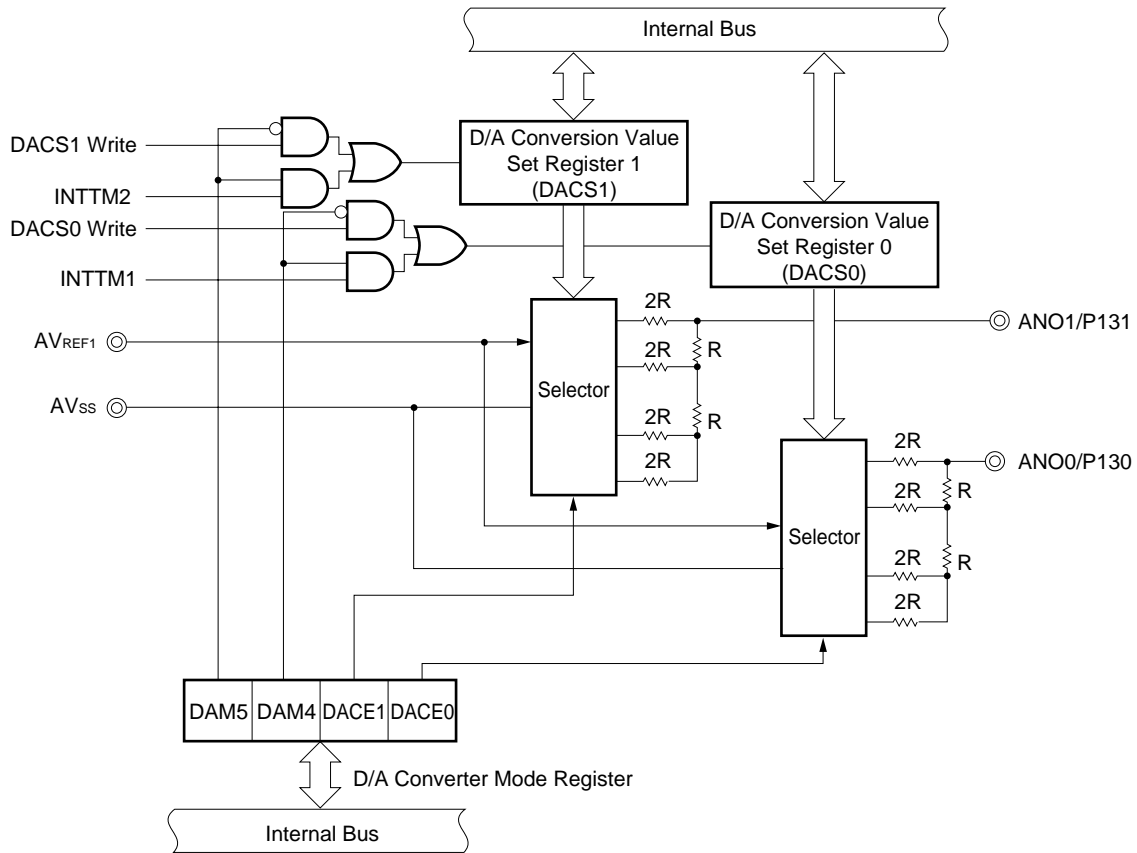
15.2 D/A Converter Configuration

The D/A converter consists of the following hardware.

Table 15-1. D/A Converter Configuration

Item	Configuration
Register	D/A conversion value set register 0 (DACS0) D/A conversion value set register 1 (DACS1)
Control register	D/A converter mode register (DAM)

Figure 15-1. D/A Converter Block Diagram



(1) D/A conversion value set register 0, 1 (DACS0, DACS1)

DACS0 and DACS1 are registers that set the values to determine analog voltage output to the ANO0 and ANO1 pins, respectively.

DACS0 and DACS1 are set with 8-bit memory manipulation instructions.

$\overline{\text{RESET}}$ input sets these registers to 00H.

Analog voltage output to the ANO0 and ANO1 pins is determined by the following expression.

$$\text{ANOn output voltage} = AV_{\text{REF1}} \times \frac{\text{DACS}_n}{256}$$

where, $n = 0, 1$

- Cautions**
1. In the real-time output mode, when data that are set in DACS0 and DACS1 are read before an output trigger is generated, the previous data are read rather than the set data.
 2. In the real-time output mode, data should be set to DACS0 and DACS1 after an output trigger and before the next output trigger.

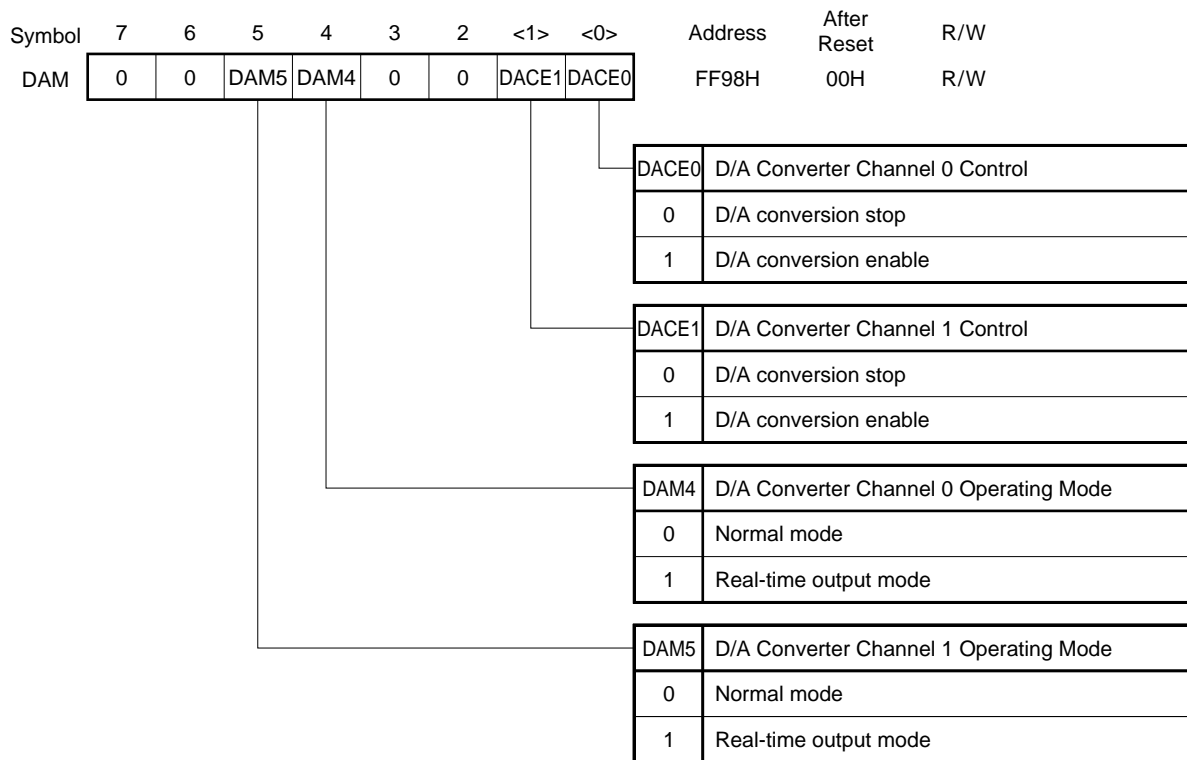
15.3 D/A Converter Control Registers

The D/A converter mode register (DAM) controls the D/A converter. This register sets D/A converter operation enable/stop.

The DAM is set with a 1-bit or 8-bit memory manipulation instruction.

$\overline{\text{RESET}}$ input sets this register to 00H.

Figure 15-2. D/A Converter Mode Register Format



- Cautions**
1. When using the D/A converter, a dual-function port pin should be set to the input mode, and a pull-up resistor should be disconnected.
 2. Always set bits 2, 3, 6, and 7 to 0.
 3. When D/A conversion is stopped, the output state is high-impedance.
 4. The output triggers are INTTM1 and INTTM2 for channel 0 and channel 1, respectively, in the real-time output mode.

15.4 Operations of D/A Converter

- (1) Select the channel 0 operating mode and channel 1 operating mode by DAM4 and DAM5 of D/A converter mode register (DAM), respectively.
- (2) Set the data corresponding to the analog voltages output to the ANO0/P130 and ANO1/P131 pins to the D/A conversion value setting registers 0 and 1 (DACS0 and DACS1), respectively.
- (3) The channel 0 and channel 1 D/A conversion operations can be started by setting DACE0 and DACE1 of the DAM, respectively.
- (4) In the normal mode, the analog voltage signals are output to the ANO0/P130 and ANO1/P131 pins immediately after the D/A conversion. In the real-time output mode, the analog voltage signals are output synchronously with the output triggers.
- (5) In the normal mode, the analog voltage signals to be output are held until new data are set in DACS0 and DACS1. In the realtime output mode, new data are set in DACS0 and DACS1 and then they are held until the next trigger is generated.

Caution Set DACE0 and DACE1 after setting data in DACS0 and DACS1.

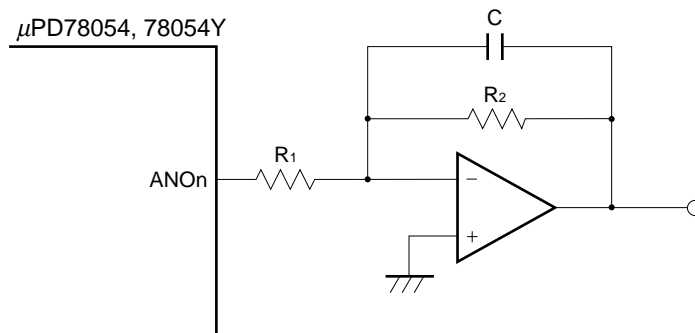
15.5 Cautions Related to D/A Converter

(1) Output impedance of D/A converter

Because the output impedance of the D/A converter is high, use of current flowing from the ANOn pins ($n = 0, 1$) is prohibited. If the input impedance of the load for the converter is low, insert a buffer amplifier between the load and the ANOn pins. In addition, wiring from the ANOn pins to the buffer amplifier or the load should be as short as possible (because of high output impedance). If the wiring may be long, design the ground pattern so as to be close to those lines or use some other expedient to achieve shorter wiring.

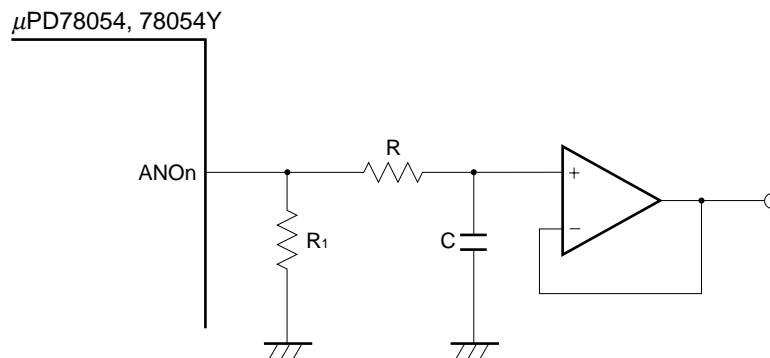
Figure 15-3. Use Example of Buffer Amplifier

(a) Inverting amplifier



- The input impedance of the buffer amplifier is R_1 .

(b) Voltage-follower



- The input impedance of the buffer amplifier is R_1 .
- If R_1 is not connected, the output becomes undefined when $\overline{\text{RESET}}$ is low.

(2) Output voltage of D/A converter

Because the output voltage of the converter changes in steps, use the D/A converter output signals in general by connecting a low-pass filter.

(3) $\text{AV}_{\text{REF}1}$ pin

When only either one of the D/A converter channels is used with $\text{AV}_{\text{REF}1} < V_{\text{DD}}$, the other pins that are not used as analog outputs must be set as follows:

- Set PM13x bit of the port mode register 13 (PM13) to 1 (input mode) and connect the pin to V_{SS} .
- Set PM13x bit of the port mode register 13 (PM13) to 0 (output mode) and the output latch to 0, to output low level from the pin.

CHAPTER 16 SERIAL INTERFACE CHANNEL 0 (μ PD78054 Subseries)

The μ PD78054 subseries incorporates three channels of serial interfaces. Differences between channels 0, 1, and 2 are as follows (Refer to **CHAPTER 18 SERIAL INTERFACE CHANNEL 1** for details of the serial interface channel 1. Refer to **CHAPTER 19 SERIAL INTERFACE CHANNEL 2** for details of the serial interface channel 2).

Table 16-1. Differences between Channels 0, 1, and 2

Serial Transfer Mode		Channel 0	Channel 1	Channel 2
3-wire serial I/O	Clock selection	$f_{xx}/2$, $f_{xx}/2^2$, $f_{xx}/2^3$, $f_{xx}/2^4$, $f_{xx}/2^5$, $f_{xx}/2^6$, $f_{xx}/2^7$, $f_{xx}/2^8$, external clock, TO2 output	$f_{xx}/2$, $f_{xx}/2^2$, $f_{xx}/2^3$, $f_{xx}/2^4$, $f_{xx}/2^5$, $f_{xx}/2^6$, $f_{xx}/2^7$, $f_{xx}/2^8$, external clock, TO2 output	Baud rate generator output
	Transfer method	MSB/LSB switchable as the start bit	MSB/LSB switchable as the start bit Automatic transmit/ receive function	MSB/LSB switchable as the start bit
	Transfer end flag	Serial transfer end interrupt request flag (CSIF0)	Serial transfer end interrupt request flag (CSIF1)	Serial transfer end interrupt request flag (SRIF)
SBI (serial bus interface)	Use possible	None	None	None
2-wire serial I/O				Use possible
UART (Asynchronous serial interface)	None			Use possible

16.1 Serial Interface Channel 0 Functions

Serial interface channel 0 employs the following four modes.

- Operation stop mode
- 3-wire serial I/O mode
- SBI (serial bus interface) mode
- 2-wire serial I/O mode

Caution Do not switch the operation mode (3-wire serial I/O, 2-wire serial I/O, SBI) of serial interface channel 0. Switch the operation mode after stopping the serial operation.

(1) Operation stop mode

This mode is used when serial transfer is not carried out. Power consumption can be reduced.

(2) 3-wire serial I/O mode (MSB-/LSB-first selectable)

This mode is used for 8-bit data transfer using three lines, one each for serial clock ($\overline{\text{SCK0}}$), serial output (SO0) and serial input (SI0). This mode enables simultaneous transmission/reception and therefore reduces the data transfer processing time.

The start bit of transferred 8-bit data is switchable between MSB and LSB, so that devices can be connected regardless of their start bit recognition.

This mode should be used when connecting with peripheral I/O devices or display controllers which incorporate a conventional synchronous clocked serial interface as is the case with the 75X/XL, 78K, and 17K series.

(3) SBI (serial bus interface) mode (MSB-first)

This mode is used for 8-bit data transfer with two or more devices using two lines of serial clock ($\overline{\text{SCK0}}$) and serial data bus (SB0 or SB1).

The SBI mode conforms to the NEC serial bus format and transmits/receives transfer data discriminating it as three types: "address", "command", and "data".

- Address : Data that selects the target device of the serial communication
- Command : Data that gives instruction to the target device
- Data : Data that is actually transmitted

For the actual transmission, the master device outputs "address" on the serial bus and selects the slave device to be the target of communication from multiple devices. Then, the serial transmission is realized by transmitting/receiving "command" and "data" between the master device and the slave device. The receive side automatically discriminates the received data as "address", "command", or "data", by hardware.

This function enables the input/output ports to be used effectively and simplifies the application program to control serial interface channel 0.

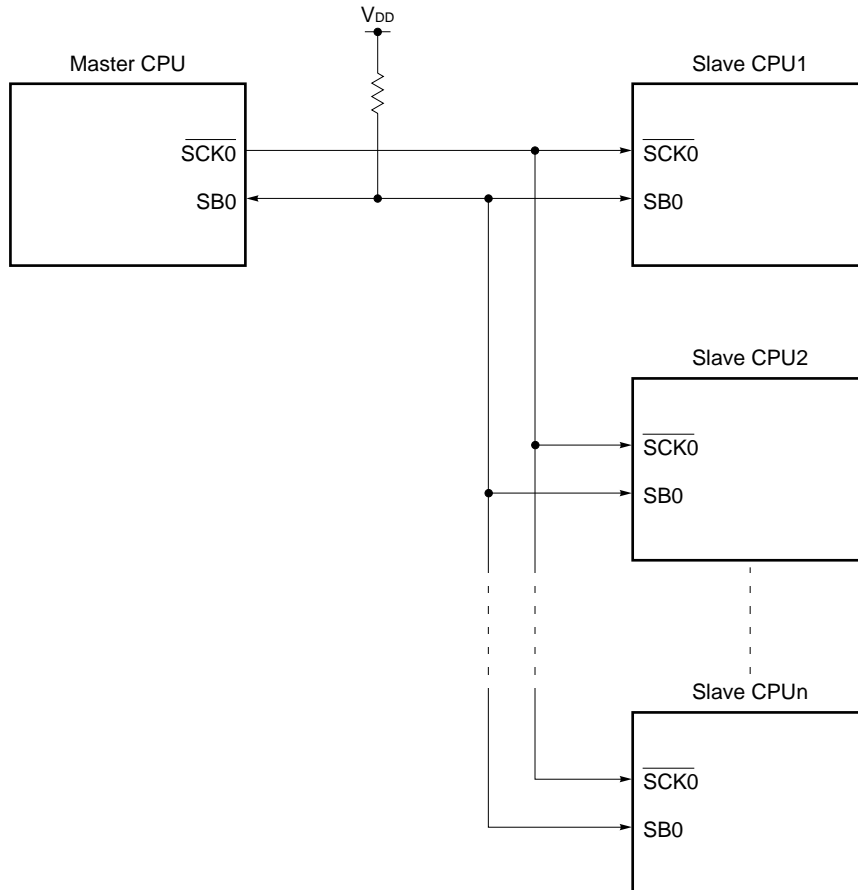
In this mode, the wake-up function for handshake and the output function of acknowledge and busy signals can also be used.

(4) 2-wire serial I/O mode (MSB-first)

This mode is used for 8-bit data transfer using two lines of serial clock ($\overline{\text{SCK0}}$) and serial data bus (SB0 or SB1).

This mode enables to cope with any one of the possible data transfer formats by controlling the $\overline{\text{SCK0}}$ level and the SB0 or SB1 output level. Thus, the handshake line previously necessary for connection of two or more devices can be used as input/output ports.

Figure 16-1. Serial Bus Interface (SBI) System Configuration Example



16.2 Serial Interface Channel 0 Configuration

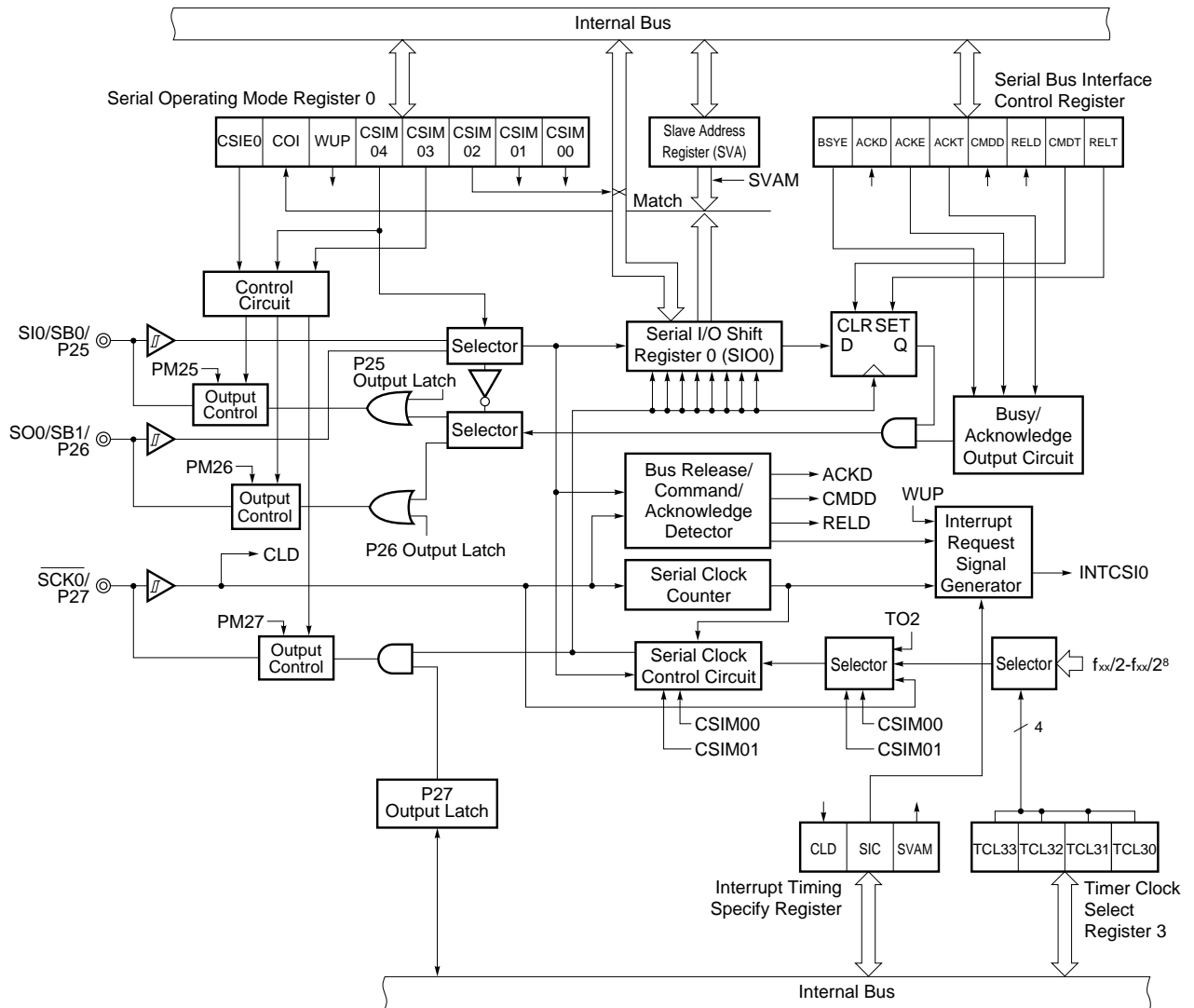
Serial interface channel 0 consists of the following hardware.

Table 16-2. Serial Interface Channel 0 Configuration

Item	Configuration
Register	Serial I/O shift register 0 (SIO0) Slave address register (SVA)
Control register	Timer clock select register 3 (TCL3) Serial operating mode register 0 (CSIM0) Serial bus interface control register (SBIC) Interrupt timing specify register (SINT) Port mode register 2 (PM2) ^{Note}

Note Refer to Figure 6-5. Block Diagram of P20, P21, P23 to P26 and Figure 6-6. Block Diagram of P22, P27.

Figure 16-2. Serial Interface Channel 0 Block Diagram



Remark Output Control performs selection between CMOS output and N-ch open-drain output.

(1) Serial I/O shift register 0 (SIO0)

This is an 8-bit register to carry out parallel/serial conversion and to carry out serial transmission/reception (shift operation) in synchronization with the serial clock.

SIO0 is set with an 8-bit memory manipulation instruction.

When bit 7 (CSIE0) of serial operating mode register 0 (CSIM0) is 1, writing data to SIO0 starts serial operation. In transmission, data written to SIO0 is output to the serial output (SO0) or serial data bus (SB0/SB1). In reception, data is read from the serial input (SI0) or SB0/SB1 to SIO0.

Note that, if a bus is driven in the SBI mode or 2-wire serial I/O mode, the bus pin must serve for both input and output. Thus, in the case of a device for reception, write FFH to SIO0 in advance (except when address reception is carried out by setting bit 5 (WUP) of CSIM0 to 1).

In the SBI mode, the busy state can be cleared by writing data to SIO0. In this case, bit 7 (BSYE) of the serial bus interface control register (SBIC) is not cleared to 0.

$\overline{\text{RESET}}$ input makes SIO0 undefined.

(2) Slave address register (SVA)

This is an 8-bit register to set the slave address value for connection of a slave device to the serial bus.

SVA is set with an 8-bit memory manipulation instruction. This register is not used in the 3-wire serial I/O mode. The master device outputs a slave address for selection of a particular slave device to the connected slave device. These two data (the slave address output from the master device and the SVA value) are compared with an address comparator. If they match, the slave device has been selected. In that case, bit 6 (COI) of serial operating mode register 0 (CSIM0) becomes 1.

The address can also be compared on the data of LSB-masked high-order 7 bits by setting bit 4 (SVAM) of the interrupt timing specify register (SINT) to (1).

If no matching is detected in address reception, bit 2 (RELD) of the serial bus interface control register (SBIC) is cleared to 0. In the SBI mode, the wake-up function can be used by setting the bit 5 (WUP) of CSIM0. In this case, the interrupt request signal (INTCSIO) is generated only when the slave address output by the master coincides with the value of SVA, and it can be learned by this interrupt request that the master requests for communication. If the bit 5 (SIC) of the interrupt timing specify register (SINT) is set to 1, the wake-up function cannot be used even if WUP is set to 1 (an interrupt request signal is generated when bus release is detected). To use the wake-up function, clear SIC to 0.

Further, when SVA transmits data as master or slave device in the SBI or 2-wire serial I/O mode, errors can be detected if any using SVA.

$\overline{\text{RESET}}$ input makes SVA undefined.

(3) SO0 latch

This latch holds SI0/SB0/P25 and SO0/SB1/P26 pin levels. It can be directly controlled also by software. In the SBI mode, this latch is set upon termination of the 8th serial clock.

(4) Serial clock counter

This counter counts the serial clocks to be output and input during transmission/reception and to check whether 8-bit data has been transmitted/received.

(5) Serial clock control circuit

This circuit controls serial clock supply to the serial I/O shift register 0 (SIO0). When the internal system clock is used, the circuit also controls clock output to the $\overline{\text{SCK0}}$ /P27 pin.

(6) Interrupt request signal generator

This circuit controls interrupt request signal generation. It generates the interrupt request signal in the following cases.

- In the 3-wire serial I/O mode and 2-wire serial I/O mode
This circuit generates an interrupt request signal every eight serial clocks.
- In the SBI mode
When WUP is 0 Generates an interrupt request signal every eight serial clocks.
When WUP is 1 Generates an interrupt request signal when the serial I/O shift register 0 (SIO0) value matches the slave address register (SVA) value after address reception.

Remark WUP is wake-up function specify bit. It is bit 5 of serial operating mode register 0 (CSIM0). To use the wake-up function (WUP = 1), clear the bit 5 (SIC) of the interrupt timing specify register (SINT) to 0.

(7) Busy/acknowledge output circuit and bus release/command/acknowledge detector

These two circuits output and detect various control signals in the SBI mode.

These do not operate in the 3-wire serial I/O mode and 2-wire serial I/O mode.

16.3 Serial Interface Channel 0 Control Registers

The following four types of registers are used to control serial interface channel 0.

- Timer clock select register 3 (TCL3)
- Serial operating mode register 0 (CSIM0)
- Serial bus interface control register (SBIC)
- Interrupt timing specify register (SINT)

(1) Timer clock select register 3 (TCL3)

This register sets the serial clock of serial interface channel 0.

TCL3 is set with an 8-bit memory manipulation instruction.

$\overline{\text{RESET}}$ input sets TCL3 to 88H.

Figure 16-3. Timer Clock Select Register 3 Format

Symbol	7	6	5	4	3	2	1	0	Address	After Reset	R/W
TCL3	TCL37	TCL36	TCL35	TCL34	TCL33	TCL32	TCL31	TCL30	FF43H	88H	R/W

				Serial Interface Channel 0 Serial Clock Selection		
TCL33	TCL32	TCL31	TCL30		MCS = 1	MCS = 0
0	1	1	0	$f_{xx}/2$	Setting prohibited	$f_x/2^2$ (1.25 MHz)
0	1	1	1	$f_{xx}/2^2$	$f_x/2^2$ (1.25 MHz)	$f_x/2^3$ (625 kHz)
1	0	0	0	$f_{xx}/2^3$	$f_x/2^3$ (625 kHz)	$f_x/2^4$ (313 kHz)
1	0	0	1	$f_{xx}/2^4$	$f_x/2^4$ (313 kHz)	$f_x/2^5$ (156 kHz)
1	0	1	0	$f_{xx}/2^5$	$f_x/2^5$ (156 kHz)	$f_x/2^6$ (78.1 kHz)
1	0	1	1	$f_{xx}/2^6$	$f_x/2^6$ (78.1 kHz)	$f_x/2^7$ (39.1 kHz)
1	1	0	0	$f_{xx}/2^7$	$f_x/2^7$ (39.1 kHz)	$f_x/2^8$ (19.5 kHz)
1	1	0	1	$f_{xx}/2^8$	$f_x/2^8$ (19.5 kHz)	$f_x/2^9$ (9.8 kHz)
Other than above				Setting prohibited		

				Serial Interface Channel 1 Serial Clock Selection		
TCL37	TCL36	TCL35	TCL34		MCS = 1	MCS = 0
0	1	1	0	$f_{xx}/2$	Setting prohibited	$f_x/2^2$ (1.25 MHz)
0	1	1	1	$f_{xx}/2^2$	$f_x/2^2$ (1.25 MHz)	$f_x/2^3$ (625 kHz)
1	0	0	0	$f_{xx}/2^3$	$f_x/2^3$ (625 kHz)	$f_x/2^4$ (313 kHz)
1	0	0	1	$f_{xx}/2^4$	$f_x/2^4$ (313 kHz)	$f_x/2^5$ (156 kHz)
1	0	1	0	$f_{xx}/2^5$	$f_x/2^5$ (156 kHz)	$f_x/2^6$ (78.1 kHz)
1	0	1	1	$f_{xx}/2^6$	$f_x/2^6$ (78.1 kHz)	$f_x/2^7$ (39.1 kHz)
1	1	0	0	$f_{xx}/2^7$	$f_x/2^7$ (39.1 kHz)	$f_x/2^8$ (19.5 kHz)
1	1	0	1	$f_{xx}/2^8$	$f_x/2^8$ (19.5 kHz)	$f_x/2^9$ (9.8 kHz)
Other than above				Setting prohibited		

Caution When rewriting TCL3 to other data, stop the serial transfer operation beforehand.

- Remarks**
1. f_{xx} : Main system clock frequency (f_x or $f_x/2$)
 2. f_x : Main system clock oscillation frequency
 3. MCS : Bit 0 of oscillation mode selection register (OSMS)
 4. Figures in parentheses apply to operation with $f_x = 5.0$ MHz.

(2) Serial operating mode register 0 (CSIM0)

This register sets serial interface channel 0 serial clock, operating mode, operation enable/stop wake-up function and displays the address comparator match signal.

CSIM0 is set with a 1-bit or 8-bit memory manipulation instruction.

$\overline{\text{RESET}}$ input sets CSIM0 to 00H.

Caution Do not switch the operation mode (3-wire serial I/O, 2-wire serial I/O, SBI) of serial interface channel 0. Switch the operation mode after stopping the serial operation.

Figure 16-4. Serial Operating Mode Register 0 Format (1/2)

Symbol	<7>	<6>	<5>	4	3	2	1	0	Address	After Reset	R/W
CSIM0	CSIE0	COI	WUP	CSIM04	CSIM03	CSIM02	CSIM01	CSIM00	FF60H	00H	R/W ^{Note 1}

R/W	CSIM01	CSIM00	Serial Interface Channel 0 Clock Selection
	0	×	Input Clock to $\overline{\text{SCK0}}$ pin from off-chip
	1	0	8-bit timer register 2 (TM2) output
	1	1	Clock specified with bits 0 to 3 of timer clock select register 3 (TCL3)

R/W	CSIM04	CSIM03	CSIM02	PM25	P25	PM26	P26	PM27	P27	Operation Mode	Start Bit	SIO/SB0/P25 Pin Function	SO0/SB1/P26 Pin Function	$\overline{\text{SCK0}}$ /P27 Pin Function
0	×	0	^{Note 2} 1	^{Note 2} ×	0	0	0	0	1	3-wire serial I/O mode	MSB	SIO ^{Note 2} (Input)	SO0 (CMOS output)	$\overline{\text{SCK0}}$ (CMOS input/output)
		1						LSB						
1	0	0	^{Note 3} ×	^{Note 3} ×	0	0	0	0	1	SBI mode	MSB	P25 (CMOS input/output)	SB1 (N-ch open-drain input/output)	$\overline{\text{SCK0}}$ (CMOS input/output)
		1	0	0	^{Note 3} ×	^{Note 3} ×	0	0	1			SB0 (N-ch open-drain input/output)	P26 (CMOS input/output)	
1	1	0	^{Note 3} ×	^{Note 3} ×	0	0	0	0	1	2-wire serial I/O mode	MSB	P25 (CMOS input/output)	SB1 (N-ch open-drain input/output)	$\overline{\text{SCK0}}$ (N-ch open-drain input/output)
		1	0	0	^{Note 3} ×	^{Note 3} ×	0	0	1			SB0 (N-ch open-drain input/output)	P26 (CMOS input/output)	

(Continued)

- Notes**
1. Bit 6 (COI) is a read-only bit.
 2. Can be used as P25 (CMOS input/output) when used only for transmission.
 3. Can be used freely as port function.

Remark × : don't care
 PM $\times\times$: Port mode register
 P $\times\times$: Port output latch

Figure 16-4. Serial Operating Mode Register 0 Format (2/2)

R/W	WUP	Wake-up Function Control ^{Note 1}
	0	Interrupt request signal generation with each serial transfer in any mode
	1	Interrupt request signal generation when the address received after bus release (when CMDD = RELD = 1) matches the slave address register (SVA) data in SBI mode
R	COI	Slave Address Comparison Result Flag ^{Note 2}
	0	Slave address register (SVA) not equal to serial I/O shift register 0 (SIO0) data
	1	Slave address register (SVA) equal to serial I/O shift register 0 (SIO0) data
R/W	CSIE0	Serial Interface Channel 0 Operation Control ^{Note 3}
	0	Operation stopped
	1	Operation enable

- Notes**
1. To use the wake-up function (WUP = 1), clear the bit 5 (SIC) of the interrupt timing specify register (SINT) to 0.
 2. When CSIE0 = 0, COI becomes 0.
 3. In the SBI mode, clear WUP to 0 before stopping (CSIE ← 0) the operation of serial interface channel 0, otherwise, P25 is fixed to high level and may not be able to be used as a normal port.

★

(3) Serial bus interface control register (SBIC)

This register sets serial bus interface operation and displays statuses.

SBIC is set with a 1-bit or 8-bit memory manipulation instruction.

$\overline{\text{RESET}}$ input sets SBIC to 00H.

Figure 16-5. Serial Bus Interface Control Register Format (1/2)

Symbol	<7>	<6>	<5>	<4>	<3>	<2>	<1>	<0>	Address	After Reset	R/W																																	
SBIC	BSYE	ACKD	ACKE	ACKT	CMDD	RELD	CMDT	RELT	FF61H	00H	R/W ^{Note}																																	
R/W	<table border="1"> <tr> <td>RELT</td> <td>Used for bus release signal output. When RELT = 1, SO0 latch is set to 1. After SO0 latch setting, automatically cleared to 0. Also cleared to 0 when CSIE0 = 0.</td> </tr> </table>											RELT	Used for bus release signal output. When RELT = 1, SO0 latch is set to 1. After SO0 latch setting, automatically cleared to 0. Also cleared to 0 when CSIE0 = 0.																															
RELT	Used for bus release signal output. When RELT = 1, SO0 latch is set to 1. After SO0 latch setting, automatically cleared to 0. Also cleared to 0 when CSIE0 = 0.																																											
R/W	<table border="1"> <tr> <td>CMDT</td> <td>Used for command signal output. When CMDT = 1, SO0 latch is cleared to (0). After SO0 latch clearance, automatically cleared to 0. Also cleared to 0 when CSIE0 = 0.</td> </tr> </table>											CMDT	Used for command signal output. When CMDT = 1, SO0 latch is cleared to (0). After SO0 latch clearance, automatically cleared to 0. Also cleared to 0 when CSIE0 = 0.																															
CMDT	Used for command signal output. When CMDT = 1, SO0 latch is cleared to (0). After SO0 latch clearance, automatically cleared to 0. Also cleared to 0 when CSIE0 = 0.																																											
R	<table border="1"> <tr> <td>RELD</td> <td colspan="10">Bus Release Detection</td> </tr> <tr> <td colspan="5">Clear Conditions (RELD = 0)</td> <td colspan="6">Set Conditions (RELD = 1)</td> </tr> <tr> <td colspan="5"> <ul style="list-style-type: none"> • When transfer start instruction is executed • If SIO0 and SVA values do not match in address reception • When CSIE0 = 0 • When RESET input is applied </td> <td colspan="6"> <ul style="list-style-type: none"> • When bus release signal (REL) is detected </td> </tr> </table>											RELD	Bus Release Detection										Clear Conditions (RELD = 0)					Set Conditions (RELD = 1)						<ul style="list-style-type: none"> • When transfer start instruction is executed • If SIO0 and SVA values do not match in address reception • When CSIE0 = 0 • When RESET input is applied 					<ul style="list-style-type: none"> • When bus release signal (REL) is detected 					
RELD	Bus Release Detection																																											
Clear Conditions (RELD = 0)					Set Conditions (RELD = 1)																																							
<ul style="list-style-type: none"> • When transfer start instruction is executed • If SIO0 and SVA values do not match in address reception • When CSIE0 = 0 • When RESET input is applied 					<ul style="list-style-type: none"> • When bus release signal (REL) is detected 																																							
R	<table border="1"> <tr> <td>CMDD</td> <td colspan="10">Command Detection</td> </tr> <tr> <td colspan="5">Clear Conditions (CMDD = 0)</td> <td colspan="6">Set Conditions (CMDD = 1)</td> </tr> <tr> <td colspan="5"> <ul style="list-style-type: none"> • When transfer start instruction is executed • When bus release signal (REL) is detected • When CSIE0 = 0 • When RESET input is applied </td> <td colspan="6"> <ul style="list-style-type: none"> • When command signal (CMD) is detected </td> </tr> </table>											CMDD	Command Detection										Clear Conditions (CMDD = 0)					Set Conditions (CMDD = 1)						<ul style="list-style-type: none"> • When transfer start instruction is executed • When bus release signal (REL) is detected • When CSIE0 = 0 • When RESET input is applied 					<ul style="list-style-type: none"> • When command signal (CMD) is detected 					
CMDD	Command Detection																																											
Clear Conditions (CMDD = 0)					Set Conditions (CMDD = 1)																																							
<ul style="list-style-type: none"> • When transfer start instruction is executed • When bus release signal (REL) is detected • When CSIE0 = 0 • When RESET input is applied 					<ul style="list-style-type: none"> • When command signal (CMD) is detected 																																							
R/W	<table border="1"> <tr> <td>ACKT</td> <td colspan="10">Acknowledge signal is output in synchronization with the falling edge clock of $\overline{\text{SCK0}}$ just after execution of the instruction to be set to 1, and after acknowledge signal output, automatically cleared to 0. Used as ACKE = 0. Also cleared to 0 upon start of serial interface transfer or when CSIE0 = 0.</td> </tr> </table>											ACKT	Acknowledge signal is output in synchronization with the falling edge clock of $\overline{\text{SCK0}}$ just after execution of the instruction to be set to 1, and after acknowledge signal output, automatically cleared to 0. Used as ACKE = 0. Also cleared to 0 upon start of serial interface transfer or when CSIE0 = 0.																															
ACKT	Acknowledge signal is output in synchronization with the falling edge clock of $\overline{\text{SCK0}}$ just after execution of the instruction to be set to 1, and after acknowledge signal output, automatically cleared to 0. Used as ACKE = 0. Also cleared to 0 upon start of serial interface transfer or when CSIE0 = 0.																																											

Note Bits 2, 3, and 6 (RELD, CMDD and ACKD) are read-only bits.

- Remarks**
1. Bits 0, 1, and 4 (RELD, CMDT, and ACKT) are 0 when read after data setting.
 2. CSIE0: Bit 7 of serial operating mode register 0 (CSIM0)

Figure 16-5. Serial Bus Interface Control Register Format (2/2)

R/W	ACKE	Acknowledge Signal Automatic Output Control	
	0	Acknowledge signal automatic output disable (output with ACKT enable)	
	1	Before completion of transfer	Acknowledge signal is output in synchronization with the 9th clock falling edge of SCK0 (automatically output when ACKE = 1).
After completion of transfer		Acknowledge signal is output in synchronization with the falling edge of SCK0 just after execution of the instruction to be set to 1 (automatically output when ACKE = 1). However, not automatically cleared to 0 after acknowledge signal output.	
R	ACKD	Acknowledge Detection	
	Clear Conditions (ACKD = 0)		Set Conditions (ACKD = 1)
	<ul style="list-style-type: none"> • Falling edge of the SCK0 immediately after the busy mode is released while executing the transfer start instruction • When CSIE0 = 0 • When RESET input is applied 		<ul style="list-style-type: none"> • When acknowledge signal (\overline{ACK}) is detected at the rising edge of SCK0 clock after completion of transfer
R/W	Note BSYE	Synchronizing Busy Signal Output Control	
	0	Disables busy signal which is output in synchronization with the falling edge of SCK0 clock just after execution of the instruction to be cleared to 0.	
	1	Outputs busy signal at the falling edge of SCK0 clock following the acknowledge signal.	

Note The busy mode can be canceled by start of serial interface transfer. However, the BSYE flag is not cleared to 0.

Remark CSIE0 : Bit 7 of serial operating mode register 0 (CSIM0)

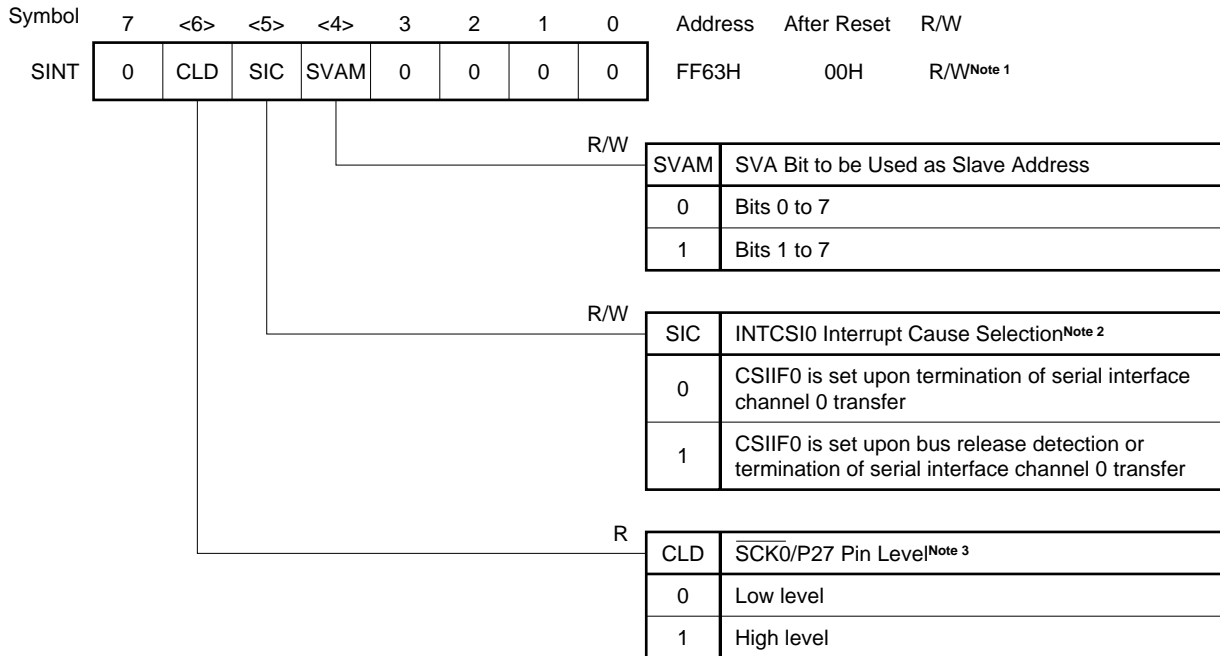
(4) Interrupt timing specify register (SINT)

This register sets the bus release interrupt and address mask functions and displays the $\overline{\text{SCK0/P27}}$ pin level status.

SINT is set with a 1-bit or 8-bit memory manipulation instruction.

$\overline{\text{RESET}}$ input sets SINT to 00H.

Figure 16-6. Interrupt Timing Specify Register Format



- Notes**
1. Bit 6 (CLD) is a read-only bit.
 2. When using wake-up function in the SBI mode, set SIC to 0.
 3. When CSIE0 = 0, CLD becomes 0.

Caution Be sure to set bits 0 to 3 to 0.

Remark

- SVA : Slave address register
- CSIIF0 : Interrupt request flag corresponding to INTCSI0
- CSIE0 : Bit 7 of serial operating mode register 0 (CSIM0)

16.4 Serial Interface Channel 0 Operations

The following four operating modes are available to the serial interface channel 0.

- Operation stop mode
- 3-wire serial I/O mode
- SBI mode
- 2-wire serial I/O mode

16.4.1 Operation stop mode

Serial transfer is not carried out in the operation stop mode. Thus, power consumption can be reduced. The serial I/O shift register 0 (SIO0) does not carry out shift operation either and thus it can be used as ordinary 8-bit register.

In the operation stop mode, the P25/SI0/SB0, P26/SO0/SB1 and P27/ $\overline{\text{SCK0}}$ pins can be used as ordinary input/output ports.

(1) Register setting

The operation stop mode is set with the serial operating mode register 0 (CSIM0).

CSIM0 is set with a 1-bit or 8-bit memory manipulation instruction.

$\overline{\text{RESET}}$ input sets CSIM0 to 00H.

Symbol	<7>	<6>	<5>	4	3	2	1	0	Address	After Reset	R/W
CSIM0	CSIE0	COI	WUP	CSIM04	CSIM03	CSIM02	CSIM01	CSIM00	FF60H	00H	R/W

R/W	CSIE0	Serial Interface Channel 0 Operation Control
	0	Operation stopped
	1	Operation enabled

16.4.2 3-wire serial I/O mode operation

The 3-wire serial I/O mode is valid for connection of peripheral I/O units and display controllers which incorporate a conventional synchronous clocked serial interface as is the case with the 75X/XL, 78K, and 17K series.

Communication is carried out with three lines of serial clock ($\overline{\text{SCK0}}$), serial output (SO0), and serial input (SI0).

(1) Register setting

The 3-wire serial I/O mode is set with the serial operating mode register 0 (CSIM0) and serial bus interface control register (SBIC).

(a) Serial operating mode register 0 (CSIM0)

CSIM0 is set with a 1-bit or 8-bit memory manipulation instruction.

$\overline{\text{RESET}}$ input sets CSIM0 to 00H.

Symbol	<7>	<6>	<5>	4	3	2	1	0	Address	After Reset	R/W
CSIM0	CSIE0	COI	WUP	CSIM04	CSIM03	CSIM02	CSIM01	CSIM00	FF60H	00H	R/W ^{Note 1}

R/W	CSIM01	CSIM00	Serial Interface Channel 0 Clock Selection
	0	×	Input Clock to $\overline{\text{SCK0}}$ pin from off-chip
	1	0	8-bit timer register 2 (TM2) output
	1	1	Clock specified with bits 0 to 3 of timer clock select register 3 (TCL3)

R/W	CSIM04	CSIM03	CSIM02	PM25	P25	PM26	P26	PM27	P27	Operation Mode	Start Bit	SIO/SB0/P25 Pin Function	SO0/SB1/P26 Pin Function	$\overline{\text{SCK0}}$ /P27 Pin Function		
	0	×	0	Note 2	Note 2	1	×	0	0	0	1	3-wire serial I/O mode	MSB	SIO ^{Note 2} (Input)	SO0 (CMOS output)	$\overline{\text{SCK0}}$ (CMOS input/output)
			1									LSB				
	1	0	SBI mode (See section 16.4.3, "SBI mode operation".)													
	1	1	2-wire serial I/O mode (See section 16.4.4, "2-wire serial I/O mode operation".)													

R/W	WUP	Wake-up Function Control ^{Note 3}
	0	Interrupt request signal generation with each serial transfer in any mode
	1	Interrupt request signal generation when the address received after bus release (when CMDD = RELD = 1) matches the slave address register (SVA) data in SBI mode

R/W	CSIE0	Serial Interface Channel 0 Operation Control
	0	Operation stopped
	1	Operation enabled

- Notes**
1. Bit 6 (COI) is a read-only bit.
 2. Can be used as P25 (CMOS input/output) when used only for transmission.
 3. Be sure to set WUP to 0 when the 3-wire serial I/O mode is selected.

Remark

- ×
- PM_{xx} : Port mode register
- P_{xx} : Port output latch

(b) Serial bus interface control register (SBIC)

SBIC is set with a 1-bit or 8-bit memory manipulation instruction.

$\overline{\text{RESET}}$ input sets SBIC to 00H.

Symbol	<7>	<6>	<5>	<4>	<3>	<2>	<1>	<0>	Address	After Reset	R/W
SBIC	BSYE	ACKD	ACKE	ACKT	CMDD	RELD	CMDT	RELT	FF61H	00H	R/W

R/W	RELT	When RELT = 1, SO0 latch is set to 1. After SO0 latch setting, automatically cleared to 0. Also cleared to 0 when CSIE0 = 0.
-----	------	---

R/W	CMDT	When CMDT = 1, SO0 latch is cleared to 0. After SO0 latch clearance, automatically cleared to 0. Also cleared to 0 when CSIE0 = 0.
-----	------	---

Remark CSIE0 : Bit 7 of serial operating mode register 0 (CSIM0)

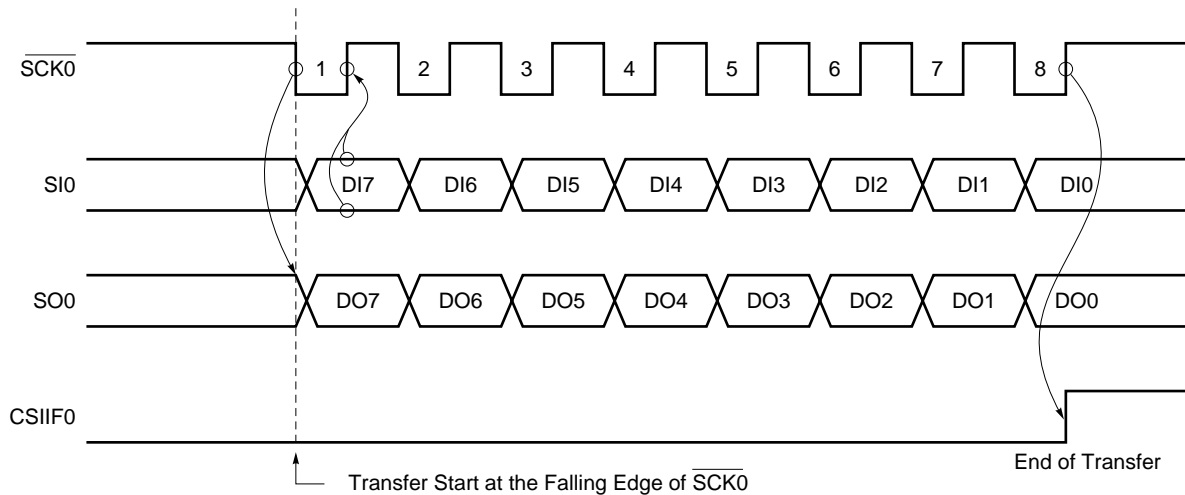
(2) Communication operation

The 3-wire serial I/O mode is used for data transmission/reception in 8-bit units. Bit-wise data transmission/reception is carried out in synchronization with the serial clock.

Shift operation of the serial I/O shift register 0 (SIO0) is carried out at the falling edge of the serial clock ($\overline{\text{SCK0}}$). The transmitted data is held in the SO0 latch and is output from the SO0 pin. The received data input to the SIO pin is latched in SIO0 at the rising edge of $\overline{\text{SCK0}}$.

Upon termination of 8-bit transfer, SIO0 operation stops automatically and the interrupt request flag (CSIF0) is set.

Figure 16-7. 3-Wire Serial I/O Mode Timings



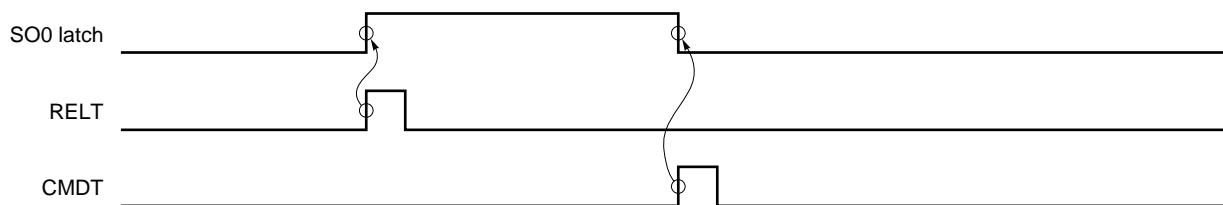
The SO0 pin is a CMOS output pin and outputs current SO0 latch statuses. Thus, the SO0 pin output status can be manipulated by setting bit 0 (RELT) and bit 1 (CMDT) of serial bus interface control register (SBIC). However, do not carry out this manipulation during serial transfer.

Control the $\overline{\text{SCK0}}$ pin output level in the output mode (internal system clock mode) by manipulating the P27 output latch (refer to **16.4.5 $\overline{\text{SCK0}}$ /P27 pin output manipulation**).

(3) Other signals

Figure 16-8 shows RELT and CMDT operations.

Figure 16-8. RELT and CMDT Operations

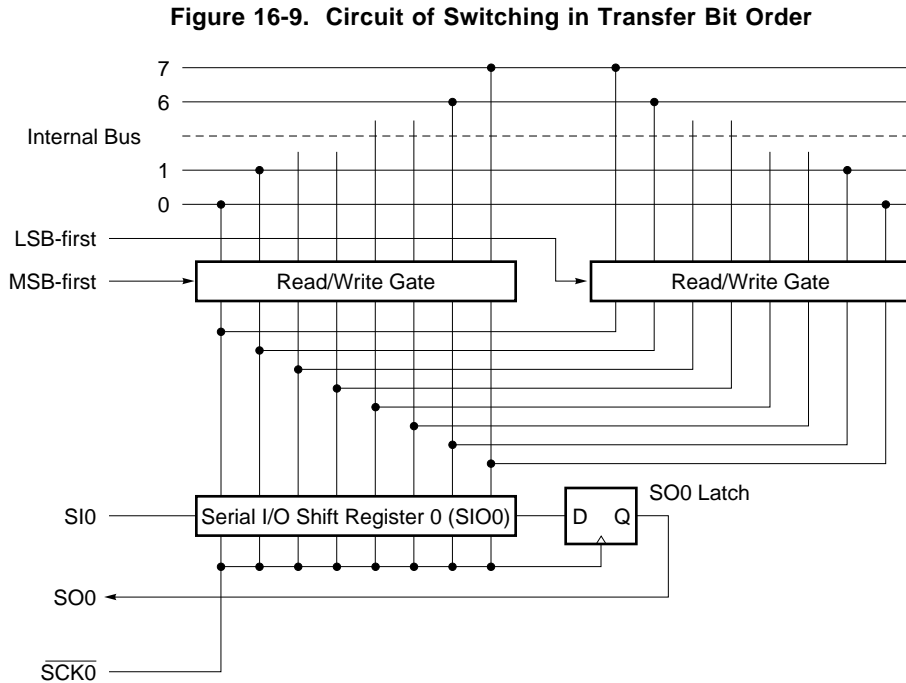


(4) MSB/LSB switching as the start bit

The 3-wire serial I/O mode enables to select transfer to start from MSB or LSB.

Figure 16-9 shows the configuration of the serial I/O shift register 0 (SIO0) and internal bus. As shown in the figure, MSB/LSB can be read/written in reverse form.

MSB/LSB switching as the start bit can be specified with bit 2 (CSIM02) of the serial operating mode register 0 (CSIM0).



Start bit switching is realized by switching the bit order for data write to SIO0. The SIO0 shift order remains unchanged.

Thus, switching between MSB-first and LSB-first must be performed before writing data to SIO0.

(5) Transfer start

Serial transfer is started by setting transfer data to the serial I/O shift register 0 (SIO0) when the following two conditions are satisfied.

- Serial interface channel 0 operation control bit (CSIE0) = 1.
- Internal serial clock is stopped or $\overline{\text{SCK0}}$ is a high level after 8-bit serial transfer.

Caution If CSIE0 is set to “1” after data write to SIO0, transfer does not start.

Upon termination of 8-bit transfer, serial transfer automatically stops and the interrupt request flag (CSIF0) is set.

16.4.3 SBI mode operation

SBI (Serial Bus Interface) is a high-speed serial interface in compliance with the NEC serial bus format.

SBI uses a single master device and employs the clocked serial I/O format with the addition of a bus configuration function. This function enables devices to communicate using only two lines. Thus, when making up a serial bus with two or more microcontrollers and peripheral ICs, the number of ports to be used and the number of wires on the board can be decreased.

The master device outputs three kinds of data to slave devices on the serial data bus: “addresses” to select a device to be communicated with, “commands” to instruct the selected device, and “data” which is actually required.

The slave device can identify the received data into “address”, “command”, or “data”, by hardware. This function simplifies the application program to control serial interface channel 0.

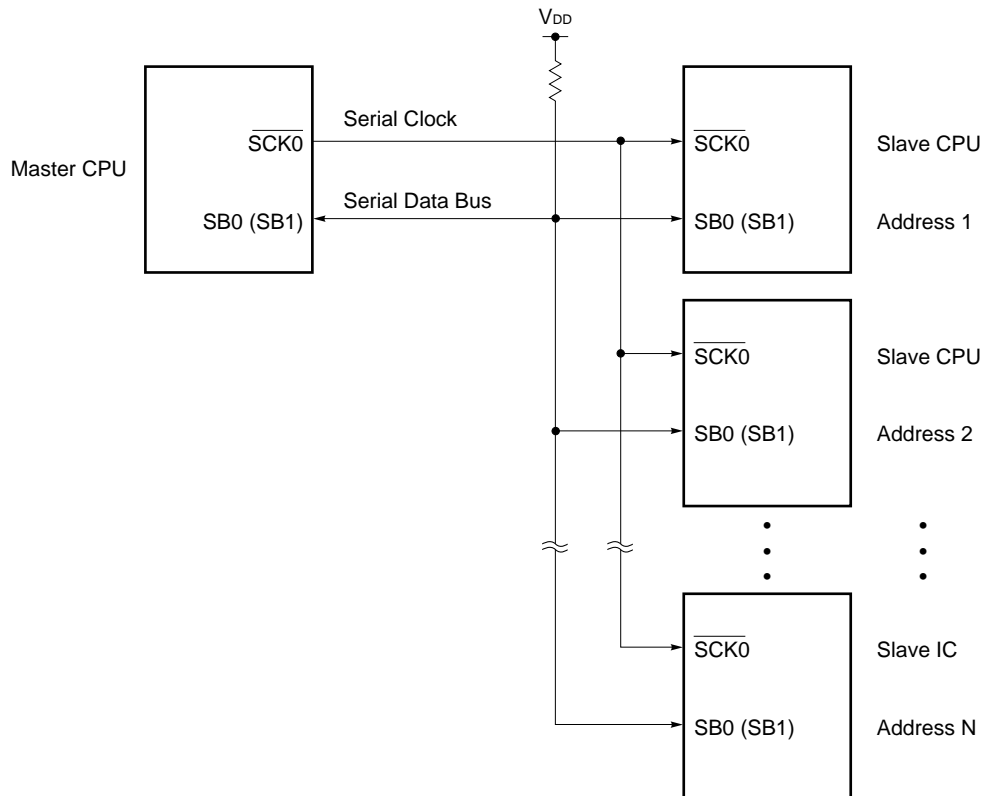
The SBI function is incorporated into various devices including 75X/XL Series and 78K Series.

Figure 16-10 shows a serial bus configuration example when a CPU having a serial interface compliant with SBI and peripheral ICs are used.

In SBI, the SB0 (SB1) serial data bus pin is an open-drain output pin and therefore the serial data bus line behaves in the same way as the wired-OR configuration. In addition, a pull-up resistor must be connected to the serial data bus line.

When the SBI mode is used, refer to **(11) SBI mode precautions (d)** described later.

Figure 16-10. Example of Serial Bus Configuration with SBI



Caution When exchanging the master CPU/slave CPU, a pull-up resistor is necessary for the serial clock line ($\overline{\text{SCK0}}$) as well because serial clock line ($\overline{\text{SCK0}}$) input/output switching is carried out asynchronously between the master and slave CPUs.

(1) SBI functions

In the conventional serial I/O format, when a serial bus is configured by connecting two or more devices, many ports and wiring are necessary, to provide chip select signal to identify command and data, and to judge the busy state, because only the data transfer function is available. If these operations are to be controlled by software, the software must be heavily loaded.

In SBI, a serial bus can be configured with two signal lines of serial clock $\overline{\text{SCK0}}$ and serial data bus SB0 (SB1). Thus, use of SBI leads to reduction in the number of microcontroller ports and that of wirings and routings on the board.

The SBI functions are described below.

(a) Address/command/data identify function

Serial data is distinguished into addresses, commands, and data.

(b) Chip select function by address transmission

The master executes slave chip selection by address transmission.

(c) Wake-up function

The slave can easily discriminate address reception (chip select) with the wake-up function (which can be set/reset by software).

When the wake-up function is set, the interrupt request signal (INTCSI0) is generated upon reception of a match address.

Thus, when communication is executed with two or more devices, the CPU except the selected slave devices can operate regardless of underway serial communications.

(d) Acknowledge signal ($\overline{\text{ACK}}$) control function

The acknowledge signal to check serial data reception is controlled.

(e) Busy signal ($\overline{\text{BUSY}}$) control function

The busy signal to report the slave busy state is controlled.

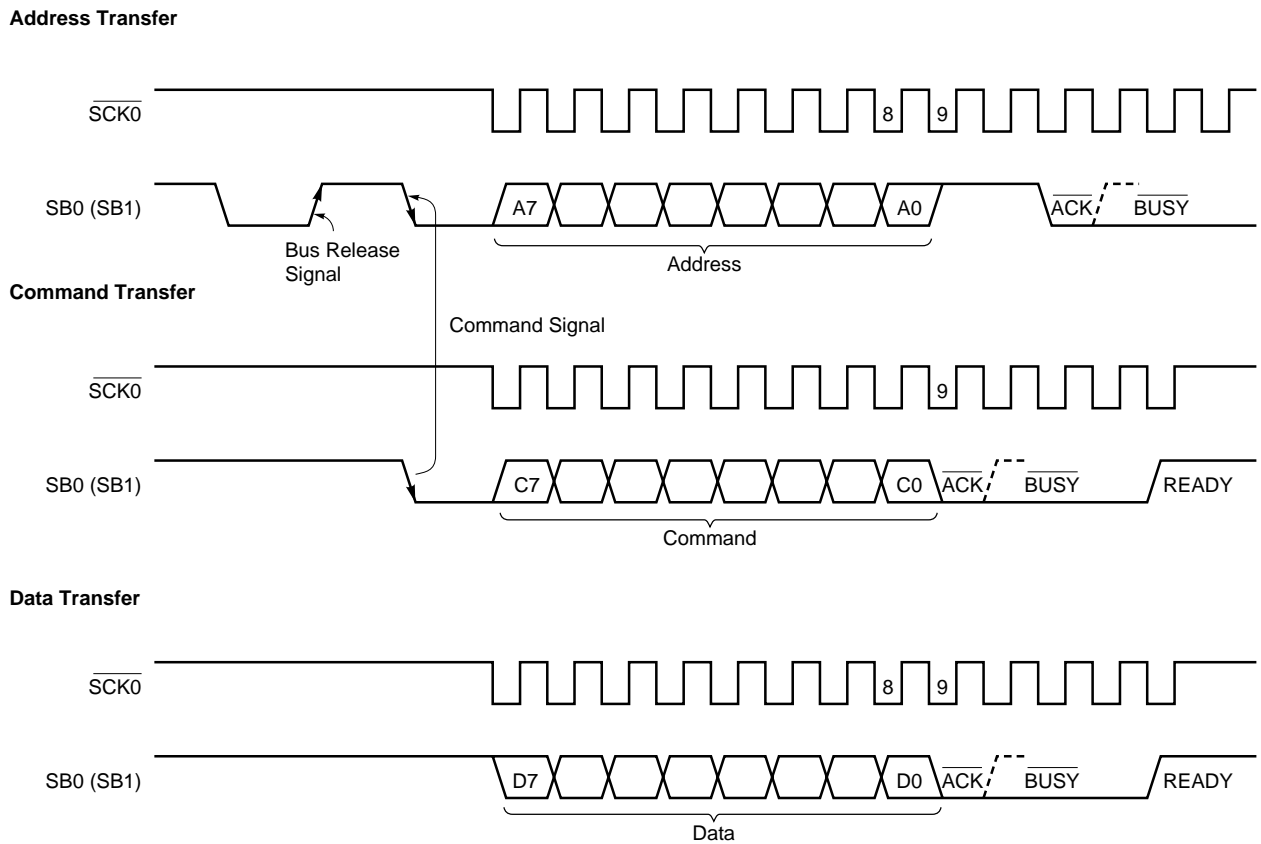
(2) SBI definition

The SBI serial data format and the signals to be used are defined as follows.

Serial data to be transferred with SBI consists of three kinds of data: "address", "command", and "data".

Figure 16-11 shows the address, command, and data transfer timings.

Figure 16-11. SBI Transfer Timings



Remark The dotted line indicates READY status.

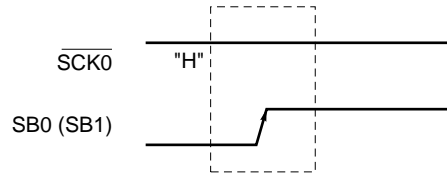
The bus release signal and the command signal are output by the master device. $\overline{\text{BUSY}}$ is output by the slave signal. $\overline{\text{ACK}}$ can be output by either the master or slave device (normally, the 8-bit data receiver outputs). Serial clocks continue to be output by the master device from 8-bit data transfer start to $\overline{\text{BUSY}}$ reset.

(a) Bus release signal (REL)

The bus release signal is a signal with the SB0 (SB1) line which has changed from the low level to the high level when the $\overline{\text{SCK0}}$ line is at the high level (without serial clock output).

This signal is output by the master device.

Figure 16-12. Bus Release Signal



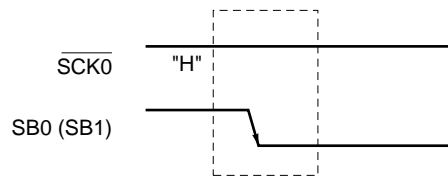
Caution A transition of the SB0 (SB1) pin from low to high while the $\overline{\text{SCK0}}$ line is high is interpreted as a bus release signal. Therefore, a shift in the change timing of the bus due to the influence of the board capacitance, etc., may be incorrectly identified as a bus release signal, regardless of whether data is being transmitted. For this reason, special care must be taken regarding wiring.

The bus release signal indicates that the master device is going to transmit an address to the slave device. The slave device incorporates hardware to detect the bus release signal.

(b) Command signal (CMD)

The command signal is a signal with the SB0 (SB1) line which has changed from the high level to the low level when the $\overline{\text{SCK0}}$ line is at the high level (without serial clock output). This signal is output by the master device.

Figure 16-13. Command Signal



A command signal indicates that the master is to transmit a command to a slave (however, the command signal following a bus release signal indicates that the master is to transmit an address).

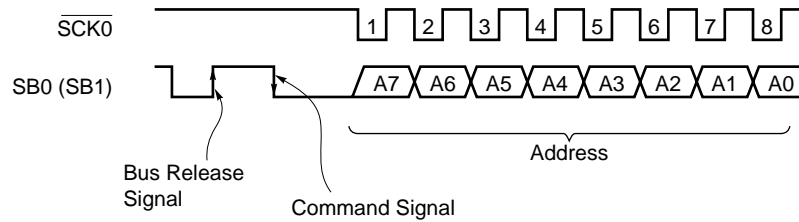
The slave device incorporates hardware to detect the command signal.

Caution A transition of the SB0 (SB1) pin from high to low while the $\overline{\text{SCK0}}$ line is high is interpreted as a command signal. Therefore, a shift in the change timing of the bus due to the influence of the board capacitance, etc., may be incorrectly identified as a command signal, regardless of whether data is being transmitted. For this reason, special care must be taken regarding wiring.

(c) Address

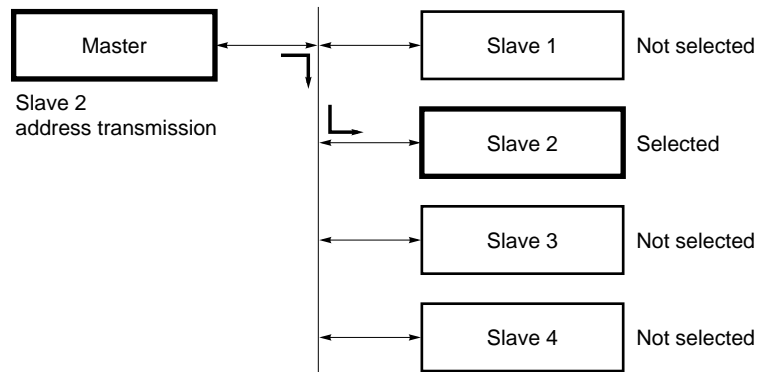
An address is 8-bit data which the master device outputs to the slave device connected to the bus line in order to select a particular slave device.

Figure 16-14. Addresses



8-bit data following bus release and command signals is defined as an “address”. In the slave device, this condition is detected by hardware and whether or not 8-bit data matches the own specification number (slave address) is checked by hardware. If the 8-bit data matches the slave address, the slave device has been selected. After that, communication with the master device continues until a release instruction is received from the master device.

Figure 16-15. Slave Selection with Address



(d) Command and data

The master device transmits commands to, and transmits/receives data to/from the slave device selected by address transmission.

Figure 16-16. Commands

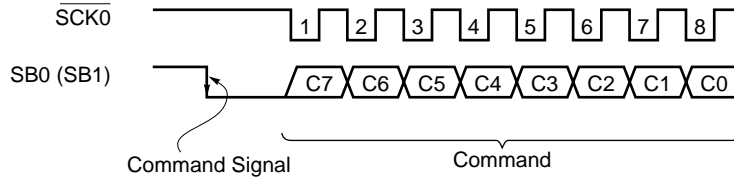
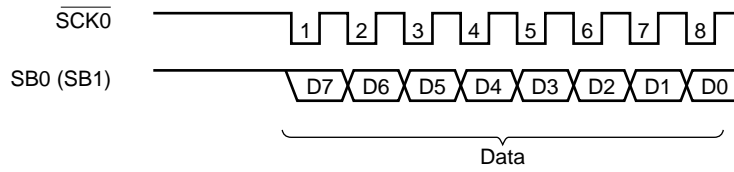


Figure 16-17. Data

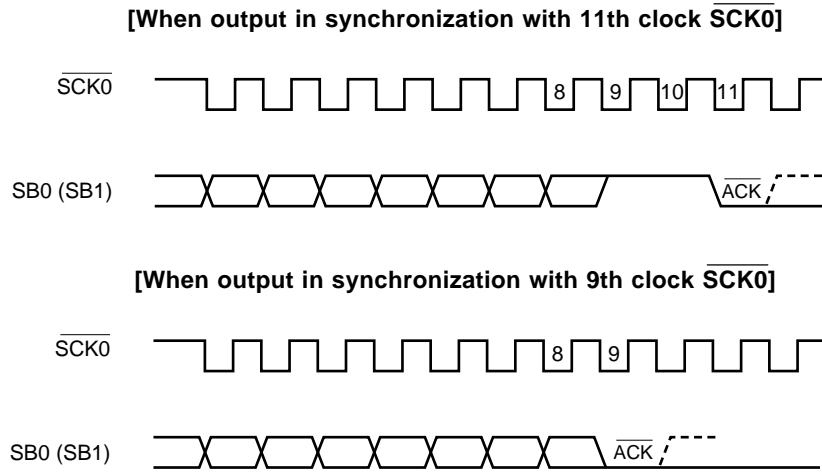


8-bit data following a command signal is defined as “command” data. 8-bit data without command signal is defined as “data”. Command and data operation procedures are allowed to determine by user according to communications specifications.

(e) Acknowledge signal ($\overline{\text{ACK}}$)

The acknowledge signal is used to check serial data reception between transmitter and receiver.

Figure 16-18. Acknowledge Signal



Remark The dotted line indicates READY status.

The acknowledge signal is one-shot pulse to be generated at the falling edge of $\overline{\text{SCK0}}$ after 8-bit data transfer. It can be positioned anywhere and can be synchronized with any clock $\overline{\text{SCK0}}$.

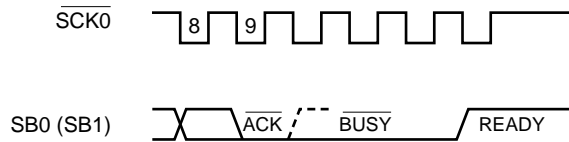
After 8-bit data transmission, the transmitter checks whether the receiver has returned the acknowledge signal. If the acknowledge signal is not returned for the preset period of time after data transmission, it can be judged that data reception has not been carried out correctly.

(f) Busy signal ($\overline{\text{BUSY}}$) and ready signal (READY)

The $\overline{\text{BUSY}}$ signal is intended to report to the master device that the slave device is preparing for data transmission/reception.

The READY signal is intended to report to the master device that the slave device is ready for data transmission/reception.

Figure 16-19. $\overline{\text{BUSY}}$ and READY Signals



In SBI, the slave device notifies the master device of the busy state by setting SB0 (SB1) line to the low level.

The $\overline{\text{BUSY}}$ signal output follows the acknowledge signal output from the master or slave device. It is set/reset at the falling edge of $\overline{\text{SCK0}}$. When the $\overline{\text{BUSY}}$ signal is reset, the master device automatically terminates the output of $\overline{\text{SCK0}}$ serial clock.

When the $\overline{\text{BUSY}}$ signal is reset and the READY signal is set, the master device can start the next transfer.

Caution SBI outputs the $\overline{\text{BUSY}}$ signal after $\overline{\text{BUSY}}$ has been cleared until the next falling edge of the serial clock. If WUP is set to 1 by mistake during this time, $\overline{\text{BUSY}}$ will not be cleared. Therefore, when setting WUP to 1, do so after clearing $\overline{\text{BUSY}}$ and then making sure that the SB0 (SB1) pin has gone high.

(3) Register setting

The SBI mode is set with the serial operating mode register 0 (CSIM0), the serial bus interface control register (SBIC), and the interrupt timing specify register (SINT).

(a) Serial operating mode register 0 (CSIM0)

CSIM0 is set with a 1-bit or 8-bit memory manipulation instruction.

$\overline{\text{RESET}}$ input sets CSIM0 to 00H.

Symbol	<7>	<6>	<5>	4	3	2	1	0	Address	After Reset	R/W
CSIM0	CSIE0	COI	WUP	CSIM04	CSIM03	CSIM02	CSIM01	CSIM00	FF60H	00H	R/W ^{Note 1}

R/W	CSIM01	CSIM00	Serial Interface Channel 0 Clock Selection
	0	×	Input Clock to $\overline{\text{SCK0}}$ pin from off-chip
	1	0	8-bit timer register 2 (TM2) output
	1	1	Clock specified with bits 0 to 3 of timer clock select register 3 (TCL3)

R/W	CSIM04	CSIM03	CSIM02	PM25	P25	PM26	P26	PM27	P27	Operation Mode	Start Bit	SI0/SB0/P25 Pin Function	SO0/SB1/P26 Pin Function	$\overline{\text{SCK0}}$ /P27 Pin Function
	0	×	3-wire serial I/O mode (16.4.2, "3-wire serial I/O mode operation.")											
	1	0	0	×	×	0	0	0	1	SBI mode	MSB	P25 (CMOS input/output)	SB1 (N-ch open-drain input/output)	$\overline{\text{SCK0}}$ (CMOS input/output)
			1	0	0	×	×	0	1			SB0 (N-ch open-drain input/output)	P26 (CMOS input/output)	
	1	1	2-wire serial I/O mode (see section 16.4.4, "2-wire serial I/O mode operation.")											

R/W	WUP	Wake-up Function Control ^{Note 3}
	0	Interrupt request signal generation with each serial transfer in any mode
	1	Interrupt request signal generation when the address received after bus release (when CMDD=RELD=1) matches the slave address register (SVA) data in SBI mode

R	COI	Slave Address Comparison Result Flag ^{Note 4}
	0	Slave address register (SVA) not equal to serial I/O shift register 0 (SIO0) data
	1	Slave address register (SVA) equal to serial I/O shift register 0 (SIO0) data

R/W	CSIE0	Serial Interface Channel 0 Operation Control
	0	Operation stopped
	1	Operation enabled

- Notes**
1. Bit 6 (COI) is a read-only bit.
 2. Can be used as a port.
 3. To use the wake-up function (WUP = 1), clear the bit 5 (SIC) of the interrupt timing specify register (SINT) to 0.
 4. When CSIE0=0, COI becomes 0.

Remark

- ×
- PM_{xx} : Port mode register
- P_{xx} : Port output latch

(b) Serial bus interface control register (SBIC)

SBIC is set with a 1-bit or 8-bit memory manipulation instruction.

$\overline{\text{RESET}}$ input sets SBIC to 00H.

The shaded area is used in the SBI mode.

Symbol	<7>	<6>	<5>	<4>	<3>	<2>	<1>	<0>	Address	After Reset	R/W
SBIC	BSYE	ACKD	ACKE	ACKT	CMDD	RELD	CMDT	RELT	FF61H	00H	R/W ^{Note}

R/W	RELT	Used for bus release signal output. When RELT = 1, SO0 latch is set to (1). After SO0 latch setting, automatically cleared to (0). Also cleared to 0 when CSIE0 = 0.
-----	------	--

R/W	CMDT	Used for command signal output. When CMDT = 1, SO0 latch is cleared to (0). After SO0 latch clearance, automatically cleared to (0). Also cleared to 0 when CSIE0 = 0.
-----	------	--

R	RELD	Bus Release Detection
Clear Conditions (RELD = 0)		Set Conditions (RELD = 1)
<ul style="list-style-type: none"> • When transfer start instruction is executed • If SIO0 and SVA values do not match in address reception (only when WUP = 1) • When CSIE0 = 0 • When $\overline{\text{RESET}}$ input is applied 		<ul style="list-style-type: none"> • When bus release signal (REL) is detected

R	CMDD	Command Detection
Clear Conditions (CMDD = 0)		Set Conditions (CMDD = 1)
<ul style="list-style-type: none"> • When transfer start instruction is executed • When bus release signal (REL) is detected • When CSIE0 = 0 • When $\overline{\text{RESET}}$ input is applied 		<ul style="list-style-type: none"> • When command signal (CMD) is detected

R/W	ACKT	Acknowledge signal is output in synchronization with the falling edge clock of $\overline{\text{SCK0}}$ just after execution of the instruction to be set to (1) and, after acknowledge signal output, automatically cleared to (0). Used as ACKE=0. Also cleared to (0) upon start of serial interface transfer or when CSIE0 = 0.
-----	------	--

R/W	ACKE	Acknowledge Signal Automatic Output Control
	0	Acknowledge signal automatic output disable (output with ACKT enable)
	1	Before completion of transfer Acknowledge signal is output in synchronization with the 9th clock falling edge of $\overline{\text{SCK0}}$ (automatically output when ACKE = 1).
		After completion of transfer Acknowledge signal is output in synchronization with falling edge clock of $\overline{\text{SCK0}}$ just after execution of the instruction to be set to 1 (automatically output when ACKE = 1). However, not automatically cleared to 0 after acknowledge signal output.

Note Bits 2, 3, and 6 (RELD, CMDD and ACKD) are read-only bits.

(Continued)

Remarks 1. Bits 0, 1, and 4 (RELT, CMDT, and ACKT) are 0 when read after data setting.

2. CSIE0 : Bit 7 of serial operating mode register 0 (CSIM0)

R	ACKD	Acknowledge Detection	
		Clear Conditions (ACKD = 0)	Set Conditions (ACKD = 1)
		<ul style="list-style-type: none"> • SCK0 fall immediately after the busy mode is released during the transfer start instruction execution. • When CSIE0 = 0 • When RESET input is applied 	<ul style="list-style-type: none"> • When acknowledge signal ($\overline{\text{ACK}}$) is detected at the rising edge of SCK0 clock after completion of transfer

R/W	Note BSYE	Synchronizing Busy Signal Output Control	
	0	Disables busy signal which is output in synchronization with the falling edge of SCK0 clock just after execution of the instruction to be cleared to (0) (sets READY status).	
	1	Outputs busy signal at the falling edge of SCK0 clock following the acknowledge signal.	

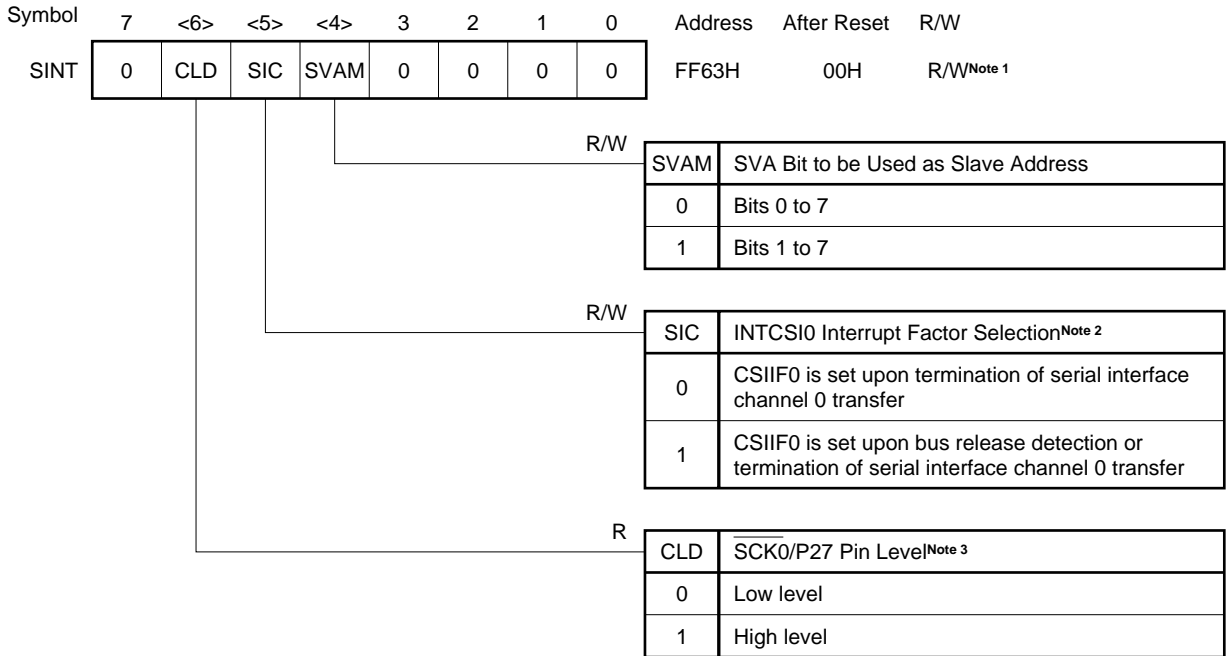
Note Busy mode can be cleared by start of serial interface transfer. However, BSYE flag is not cleared to 0.

Remark CSIE0 : Bit 7 of serial operating mode register 0 (CSIM0)

(c) Interrupt timing specify register (SINT)

SINT is set with a 1-bit or 8-bit memory manipulation instruction.

$\overline{\text{RESET}}$ input sets SINT to 00H.



- Notes**
1. Bit 6 (CLD) is a read-only bit.
 2. When using wake-up function in the SBI mode, set SIC to 0.
 3. When CSIE0 = 0, CLD becomes 0.

Caution Be sure to set bits 0 to 3 to 0.

Remark

- SVA : Slave address register
- CSIF0 : Interrupt request flag corresponding to INTCSI0
- CSIE0 : Bit 7 of serial operating mode register 0 (CSIM0)

(4) Various signals

Figures 16-20 to 16-25 show various signals and flag operations in SBI. Table 16-3 lists various signals in SBI.

Figure 16-20. RELT, CMDT, RELD, and CMDD Operations (Master)

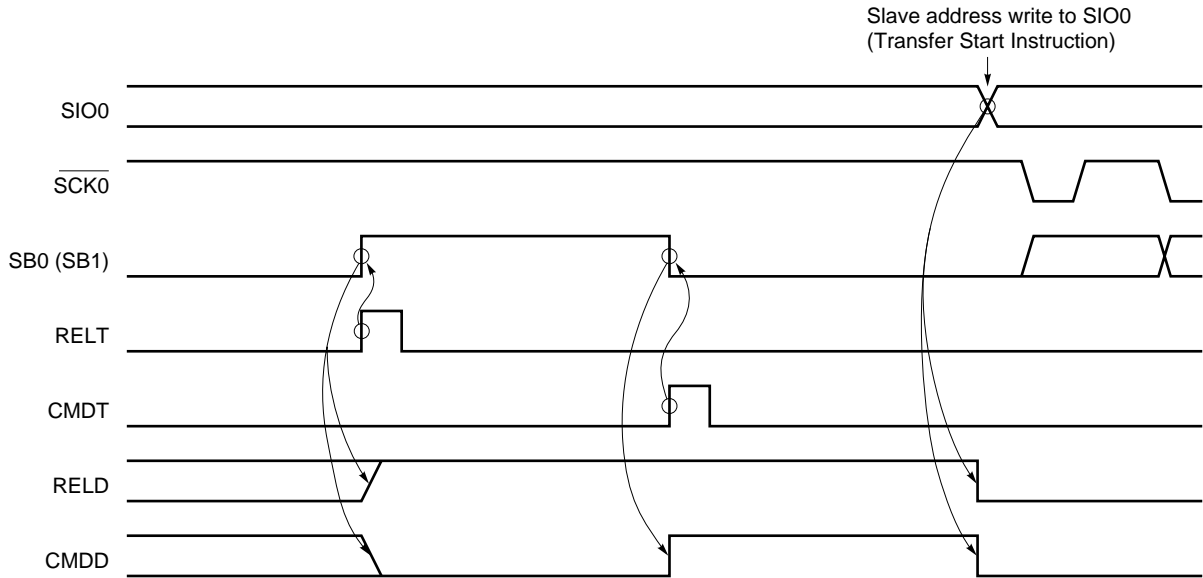


Figure 16-21. RELT and CMDD Operations (Slave)

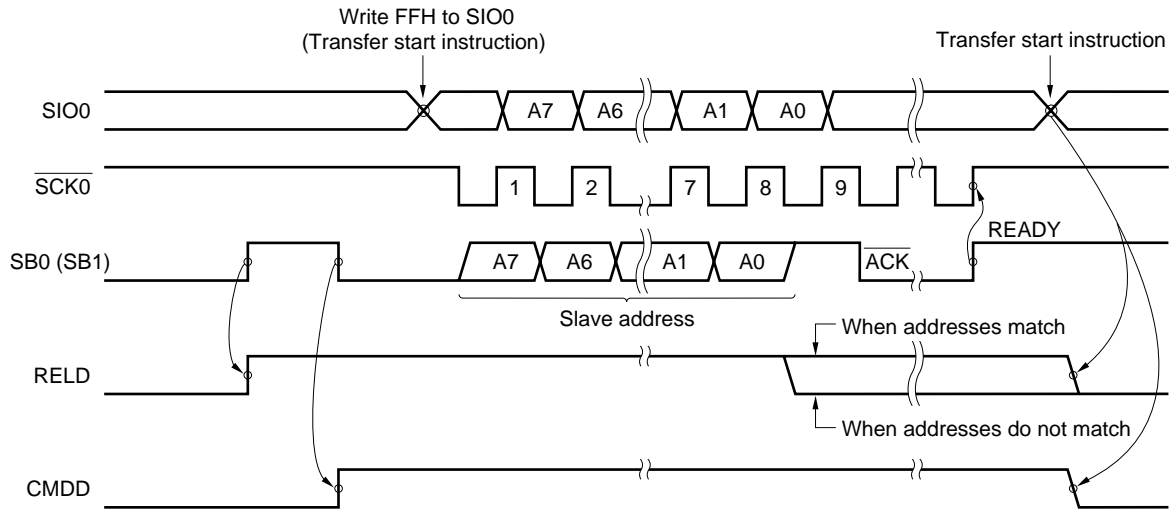
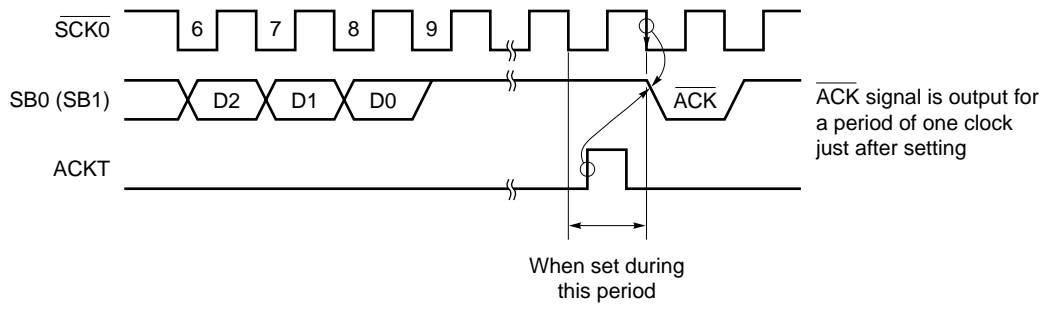


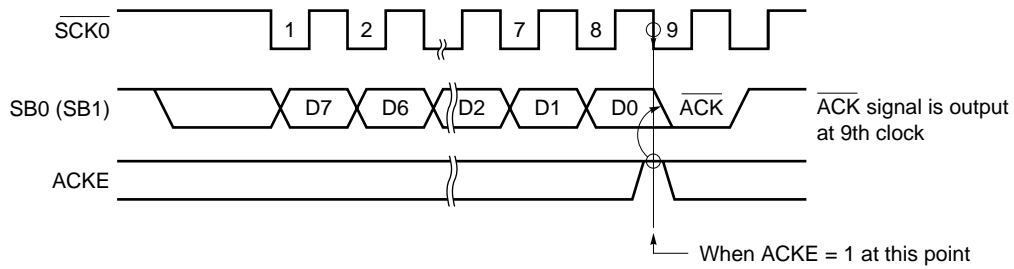
Figure 16-22. ACKT Operation



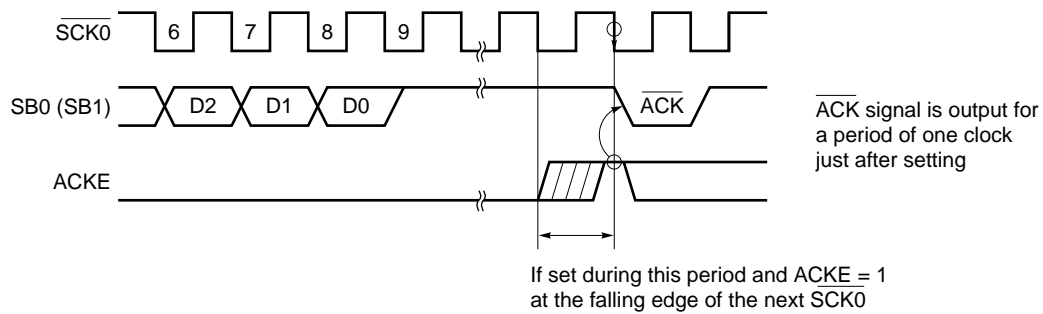
Caution Do not set ACKT before termination of transfer.

Figure 16-23. ACKE Operations

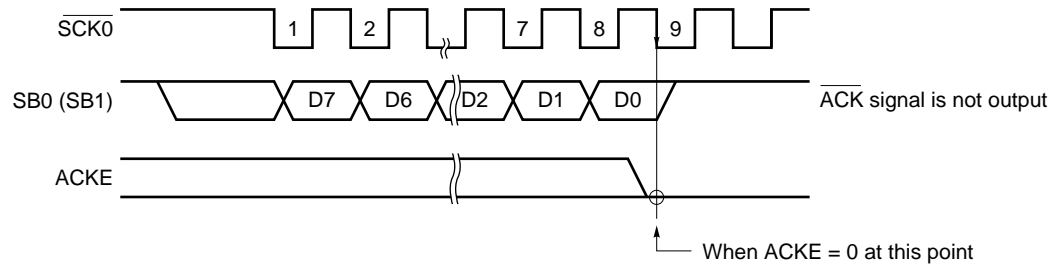
(a) When ACKE = 1 upon completion of transfer



(b) When set after completion of transfer



(c) When ACKE = 0 upon completion of transfer



(d) When "ACKE = 1" period is short

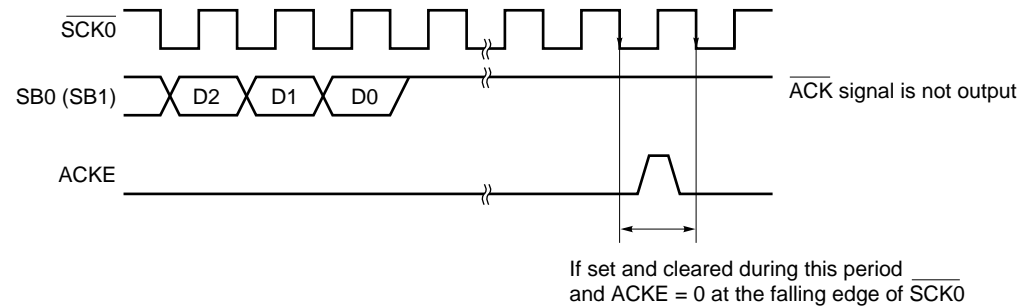


Figure 16-24. ACKD Operations

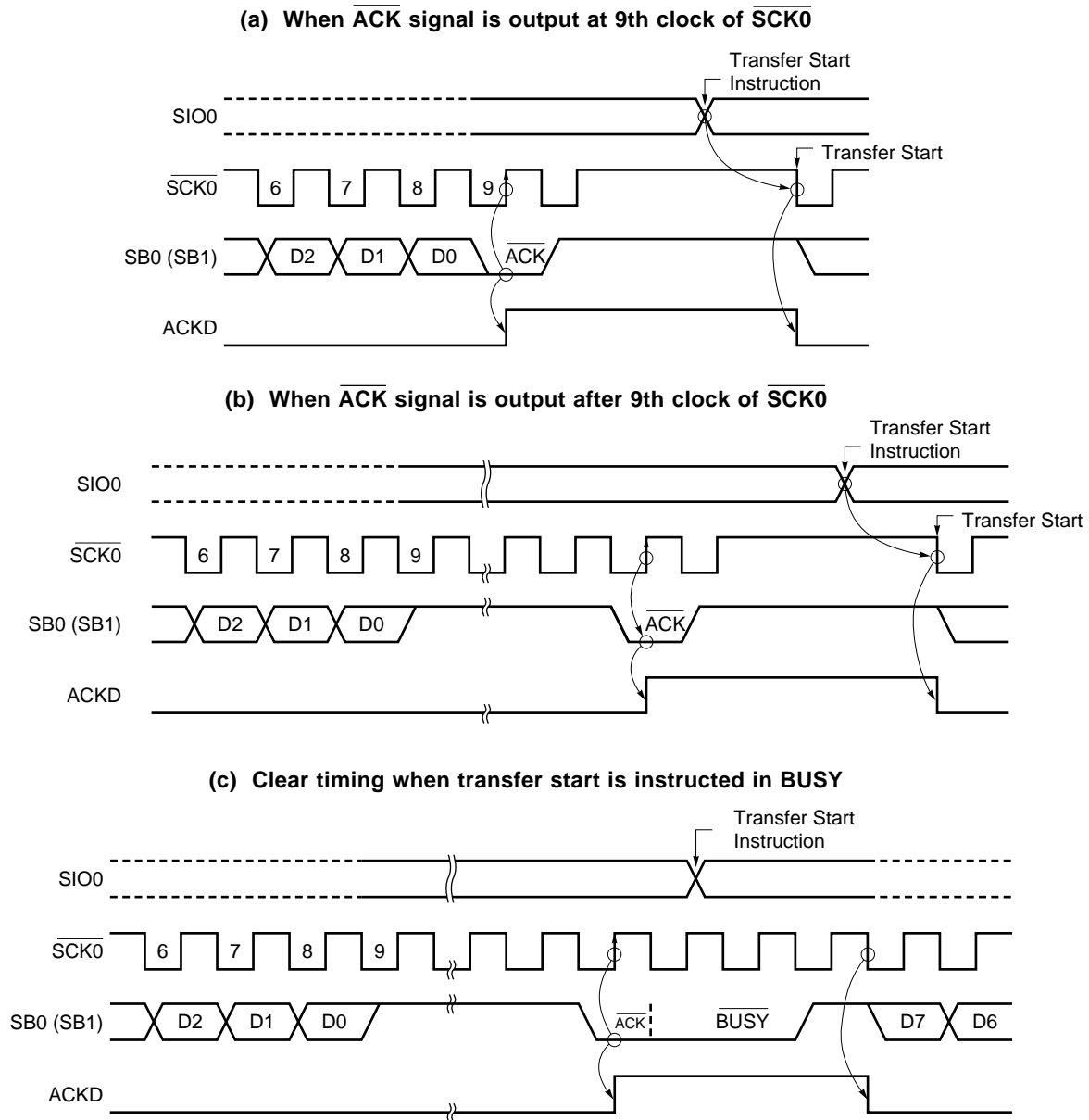


Figure 16-25. BSYE Operation

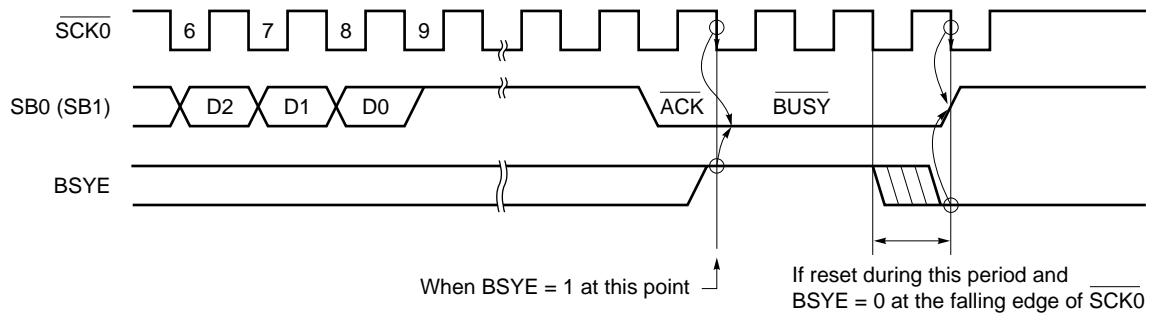


Table 16-3. Various Signals in SBI Mode (1/2)

Signal Name	Output Device	Definition	Timing Chart	Output Condition	Effects on Flag	Meaning of Signal
Bus release signal (REL)	Master	SB0 (SB1) rising edge when $\overline{SCK0} = 1$		• RELT set	• RELD set • CMDD clear	CMD signal is output to indicate that transmit data is an address.
Command signal (CMD)	Master	SB0 (SB1) falling edge when $\overline{SCK0} = 1$		• CMDT set	• CMDD set	i) Transmit data is an address after REL signal output. ii) REL signal is not output and transmit data is an command.
Acknowledge signal (\overline{ACK})	Master/ slave	Low-level signal to be output to SB0 (SB1) during one-clock period of $\overline{SCK0}$ after completion of serial reception	[Synchronous BUSY output]	<1> ACKE = 1 <2> ACKT set	• ACKD set	Completion of reception
Busy signal (BUSY)	Slave	[Synchronous BUSY signal] Low-level signal to be output to SB0 (SB1) following Acknowledge signal		• BSYE = 1	—	Serial receive disable because of processing
Ready signal (READY)	Slave	High-level signal to be output to SB0 (SB1) before serial transfer start and after completion of serial transfer		<1> BSYE = 0 <2> Execution of instruction for data write to SIO0 (transfer start instruction)	—	Serial receive enable

Table 16-3. Various Signals in SBI Mode (2/2)

Signal Name	Output Device	Definition	Timing Chart	Output Condition	Effects on Flag	Meaning of Signal
Serial clock ($\overline{\text{SCK0}}$)	Master	Synchronous clock to output address/command/data, $\overline{\text{ACK}}$ signal, synchronous $\overline{\text{BUSY}}$ signal, etc. Address/command/data are transferred with the first eight synchronous clocks.				Timing of signal output to serial data bus
Address (A7 to A0)	Master	8-bit data to be transferred in synchronization with $\overline{\text{SCK0}}$ after output of REL and CMD signals		When CSIE0 = 1, execution of instruction for data write to SIO0 (serial transfer start instruction) ^{Note 2}	CSIF0 set (rising edge of 9th clock of $\overline{\text{SCK0}}$) ^{Note 1}	Address value of slave device on the serial bus
Commands (C7 to C0)	Master	8-bit data to be transferred in synchronization with $\overline{\text{SCK0}}$ after output of only CMD signal without REL signal output				Instructions and messages to the slave device
Data (D7 to D0)	Master/slave	8-bit data to be transferred in synchronization with $\overline{\text{SCK0}}$ without output of REL and CMD signals				Numeric values to be processed with slave or master device

Notes 1. When WUP = 0, CSIF0 is set at the rising edge of the 9th clock of $\overline{\text{SCK0}}$.

When WUP = 1, an address is received. Only when the address matches the slave address register (SVA) value, CSIF0 is set. (if the address does not coincide with the value of SVA, RELD is cleared).

2. In $\overline{\text{BUSY}}$ state, transfer starts after the READY state is set.

(5) Pin configuration

The serial clock pin $\overline{\text{SCK0}}$ and serial data bus pin SB0 (SB1) have the following configurations.

(a) $\overline{\text{SCK0}}$ Serial clock input/output pin

<1> Master ... CMOS and push-pull output

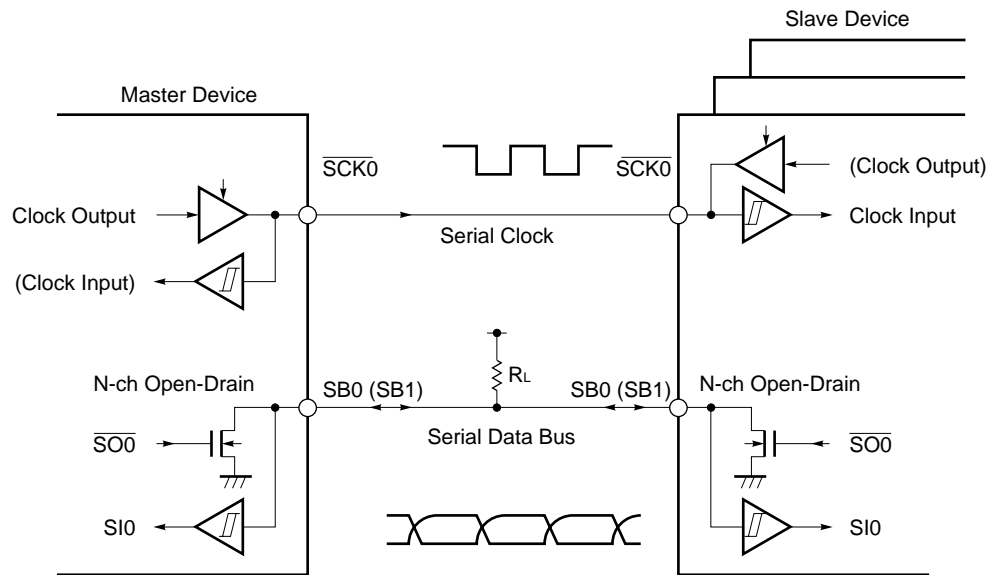
<2> Slave Schmitt input

(b) SB0 (SB1) Serial data input/output dual-function pin

Both master and slave devices have an N-ch open drain output and a Schmitt input.

Because the serial data bus line has an N-ch open-drain output, an external pull-up resistor is necessary.

Figure 16-26. Pin Configuration



Caution Because the N-ch open-drain output must be high-impedance state at time of data reception, write FFH to serial I/O shift register 0 (SIO0) in advance. The N-ch open-drain can be high-impedance state at any time of transfer. However, when the wake-up function specify bit (WUP) = 1, the N-ch open-drain output always becomes high-impedance state. Thus, it is not necessary to write FFH to SIO0 before reception.

(6) Address match detection method

In the SBI mode, the master transmits a slave address to select a specific slave device.

Coincidence of the addresses can be automatically detected by hardware. CSIF0 is set only when the slave address transmitted by the master coincides with the address set to SVA when the wake-up function specify bit (WUP) = 1.

If the bit 5 (SIC) of the interrupt timing specify register (SINT) is set, the wake-up function cannot be used even if WUP is set (an interrupt request signal is generated when bus release is detected). To use the wake-up function, clear SIC to 0.

Cautions 1. Slave selection/non-selection is detected by matching of the slave address received after bus release (RELD = 1).

For this match detection, match interrupt request (INTCSI0) of the address to be generated with WUP = 1 is normally used. Thus, execute selection/non-selection detection by slave address when WUP = 1.

2. When detecting selection/non-selection without the use of interrupt request with WUP = 0, do so by means of transmission/reception of the command preset by program instead of using the address match detection method.

(7) Error detection

In the SBI mode, the serial bus SB0 (SB1) status being transmitted is fetched into the destination device, that is, the serial I/O shift register 0 (SIO0). Thus, transmit errors can be detected in the following way.

(a) Method of comparing SIO0 data before transmission to that after transmission

In this case, if two data differ from each other, a transmit error is judged to have occurred.

(b) Method of using the slave address register (SVA)

Transmit data is set to both SIO0 and SVA and is transmitted. After termination of transmission, COI bit (match signal coming from the address comparator) of the serial operating mode register 0 (CSIM0) is tested. If "1", normal transmission is judged to have been carried out. If "0", a transmit error is judged to have occurred.

(8) Communication operation

In the SBI mode, the master device selects normally one slave device as communication target from among two or more devices by outputting an "address" to the serial bus.

After the communication target device has been determined, commands and data are transmitted/received and serial communication is realized between the master and slave devices.

Figures 16-27 to 16-30 show data communication timing charts.

Shift operation of the serial I/O shift register 0 (SIO0) is carried out at the falling edge of serial clock ($\overline{\text{SCK0}}$). Transmit data is latched into the SO0 latch and is output with MSB set as the first bit from the SB0/P25 or SB1/P26 pin. Receive data input to the SB0 (or SB1) pin at the rising edge of $\overline{\text{SCK0}}$ is latched into the SIO0.

Figure 16-27. Address Transmission from Master Device to Slave Device (WUP = 1)

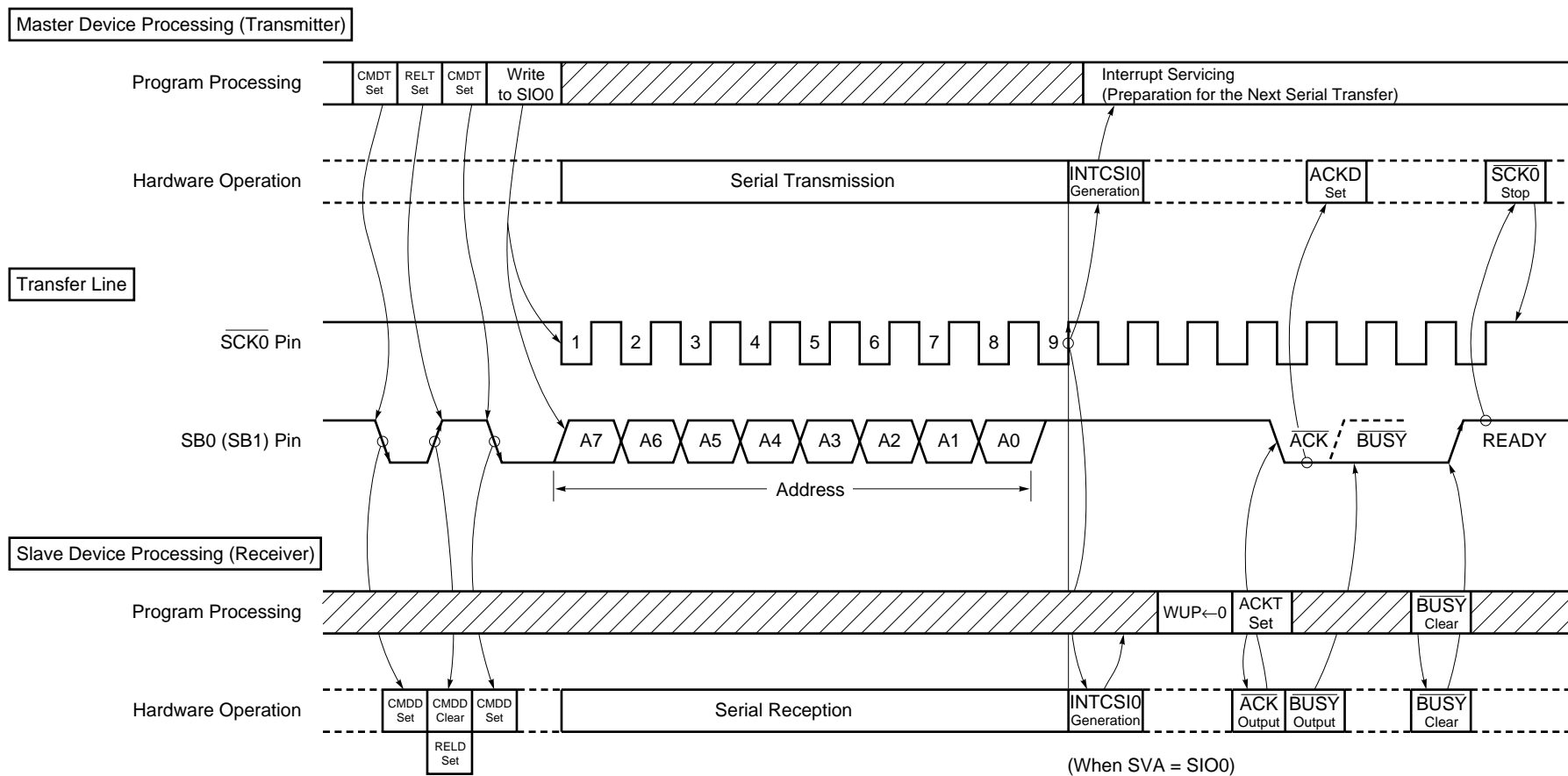


Figure 16-28. Command Transmission from Master Device to Slave Device

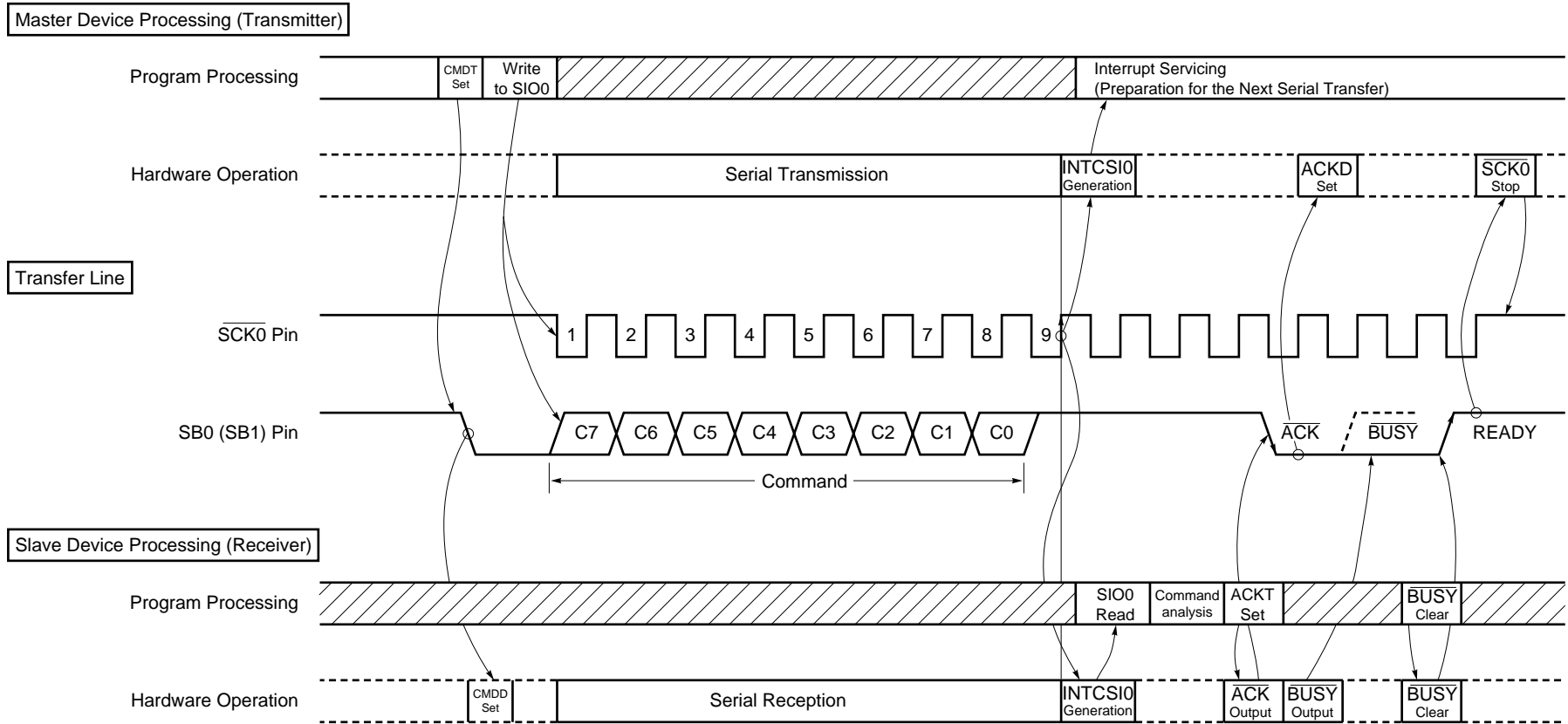


Figure 16-29. Data Transmission from Master Device to Slave Device

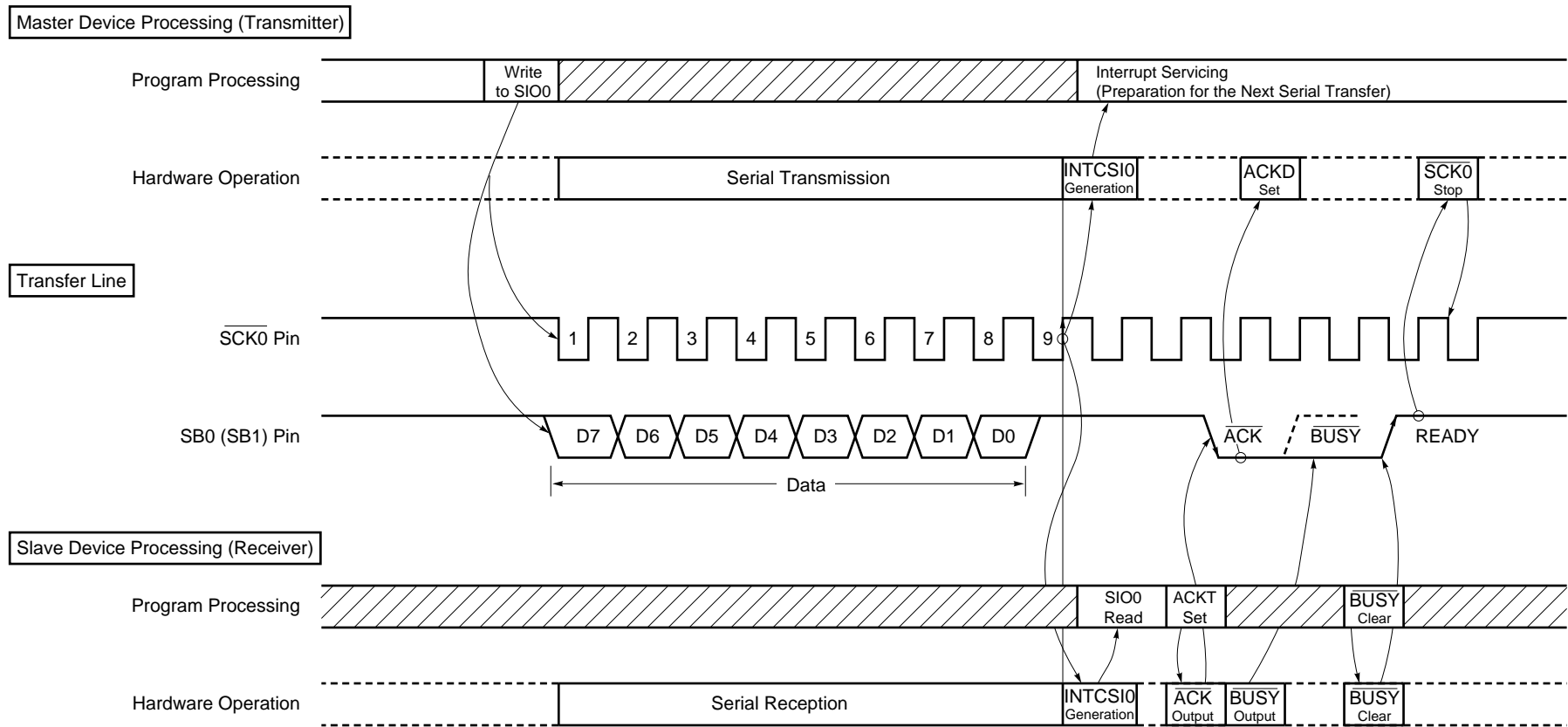
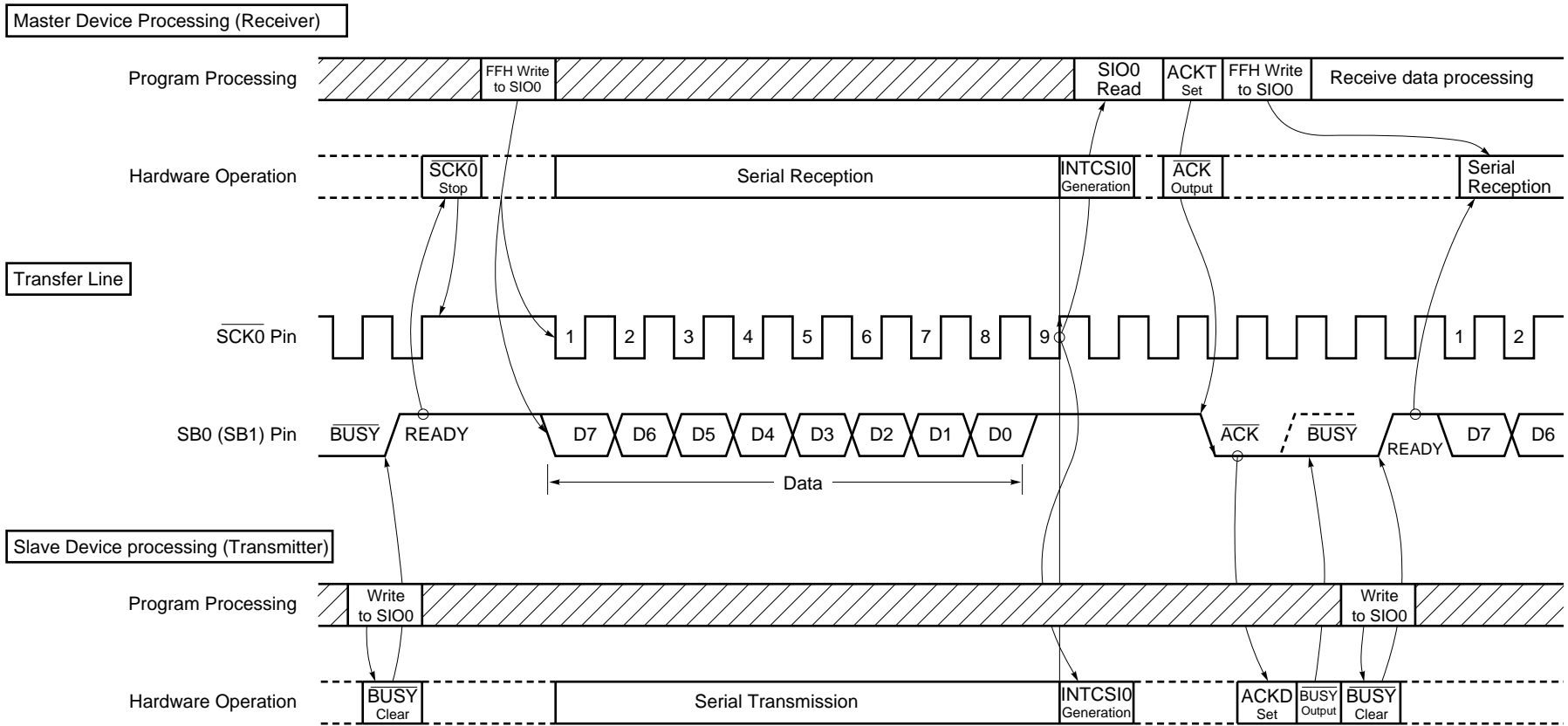


Figure 16-30. Data Transmission from Slave Device to Master Device



(9) Transfer start

Serial transfer is started by setting transfer data to the serial I/O shift register 0 (SIO0) when the following two conditions are satisfied.

- Serial interface channel 0 operation control bit (CSIE0) = 1
- Internal serial clock is stopped or $\overline{\text{SCK0}}$ is at high level after 8-bit serial transfer.

Cautions 1. If CSIE0 is set to “1” after data write to SIO0, transfer does not start.

2. Because the N-ch open-drain output must be high-impedance state for data reception, write FFH to SIO0 in advance.

However, when the wake-up function specify bit (WUP) = 1, the N-ch open-drain output is always high-impedance state. Thus, it is not necessary to write FFH to SIO0.

3. If data is written to SIO0 when the slave is busy, the data is not lost.

When the busy state is cleared and SB0 (or SB1) input is set to the high level (READY) state, transfer starts.

Upon termination of 8-bit transfer, serial transfer automatically stops and the interrupt request flag (CSIF0) is set.

Perform the following settings to the pins used for input/output of data (SB0 or SB1) after inputting $\overline{\text{RESET}}$ before the first byte of serial transmission.

- <1> Set the P25 and P26 output latches to 1.
- <2> Set bit 0 (RELT) of the serial bus interface control register (SBIC) to 1.
- <3> Reset the P25 and P26 output latches from 1 to 0.

(10) Discrimination of slave busy state

When device is in the master mode, follow the procedure below to judge whether slave device is in the busy state or not.

- <1> Detect acknowledge signal ($\overline{\text{ACK}}$) or interrupt request signal generation.
- <2> Set the port mode register PM25 (or PM26) of the SB0/P25 (or SB1/P26) pin into the input mode.
- <3> Read out the pin state (when the pin level is high, the READY state is set).

After the detection of the READY state, set the port mode register to 0 and return to the output mode.

(11) SBI mode precautions

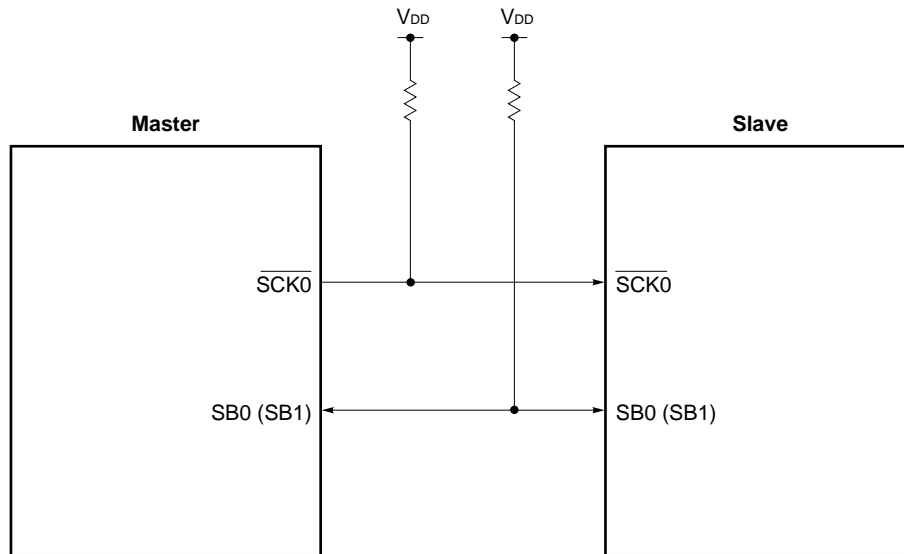
- (a) Slave selection/non-selection is detected by match detection of the slave address received after bus release (RELD = 1).
For this match detection, match interrupt (INTCSI0) of the address to be generated with WUP = 1 is normally used. Thus, execute selection/non-selection detection by slave address when WUP = 1.
- (b) When detecting selection/non-selection without the use of interrupt with WUP = 0, do so by means of transmission/reception of the command preset by program instead of using the address match detection method.
- (c) A transition of the SB0 (SB1) pin from low to high or high to low while the $\overline{\text{SCK0}}$ line is high is interpreted as a bus release or command signal. Therefore, a shift in the change timing of the bus due to the influence of the board capacitance, etc., may be incorrectly identified as a bus release signal (or command signal), regardless of whether data is being transmitted. For this reason, special care must be taken regarding wiring.
- (d) For pins which are to be used for data input/output, be sure to carry out the following settings before serial transfer of the 1st byte after $\overline{\text{RESET}}$ input.
 - <1> Set the P25 and P26 output latches to 1.
 - <2> Set bit 0 (RELT) of the serial bus interface control register (SBIC) to 1.
 - <3> Reset the P25 and P26 output latches from 1 to 0.
- (e) If SB0 (SB1) line changes from low level to high level or from high level to low level while $\overline{\text{SCK0}}$ line is high level, it is recognized as a bus release signal or a command signal. Therefore, if a lag of changing timing occurs on the bus because of the substrate capacity, etc., it may be judged as a bus release signal (command signal) despite that data is being transmitted. Exercise care for wiring.

16.4.4 2-wire serial I/O mode operation

The 2-wire serial I/O mode can cope with any communication format by program.

Communication is basically carried out with two lines of serial clock ($\overline{\text{SCK0}}$) and serial data input/output (SB0 or SB1).

Figure 16-31. Serial Bus Configuration Example Using 2-Wire Serial I/O Mode



(1) Register setting

The 2-wire serial I/O mode is set with the serial operating mode register 0 (CSIM0), the serial bus interface control register (SBIC), and the interrupt timing specify register (SINT).

(a) Serial operating mode register 0 (CSIM0)

CSIM0 is set with a 1-bit or 8-bit memory manipulation instruction.

$\overline{\text{RESET}}$ input sets CSIM0 to 00H.

Symbol	<7>	<6>	<5>	4	3	2	1	0	Address	After Reset	R/W
CSIM0	CSIE0	COI	WUP	CSIM04	CSIM03	CSIM02	CSIM01	CSIM00	FF60H	00H	R/W ^{Note 1}

R/W	CSIM01	CSIM00	Serial Interface Channel 0 Clock Selection
	0	×	Input Clock to $\overline{\text{SCK0}}$ pin from off-chip
	1	0	8-bit timer register 2 (TM2) output
	1	1	Clock specified with bits 0 to 3 of timer clock select register 3 (TCL3)

R/W	CSIM04	CSIM03	CSIM02	PM25	P25	PM26	P26	PM27	P27	Operation Mode	Start Bit	SIO/SB0/P25 Pin Function	SO0/SB1/P26 Pin Function	$\overline{\text{SCK0}}$ /P27 Pin Function
	0	×	3-wire Serial I/O mode (See Section 16.4.2, "3-wire serial I/O mode operation")											
	1	0	SBI mode (See section 16.4.3, "SBI mode operation")											
	1	1	0	^{Note 2} ×	^{Note 2} ×	0	0	0	1	2-wire serial I/O mode	MSB	P25 (CMOS input/output)	SB1 (N-ch open-drain input/output)	$\overline{\text{SCK0}}$ (N-ch open-drain input/output)
			1	0	0	^{Note 2} ×	^{Note 2} ×	0	1			SB0 (N-ch open-drain input/output)	P26 (CMOS input/output)	

R/W	WUP	Wake-up Function Control ^{Note 3}
	0	Interrupt request signal generation with each serial transfer in any mode
	1	Interrupt request signal generation when the address received after bus release (when CMDD=RELD=1) matches the slave address register (SVA) data in SBI mode

R	COI	Slave Address Comparison Result Flag ^{Note 4}
	0	Slave address register (SVA) not equal to serial I/O shift register 0 (SIO0) data
	1	Slave address register (SVA) equal to serial I/O shift register 0 (SIO0) data

R/W	CSIE0	Serial Interface Channel 0 Operation Control
	0	Operation stopped
	1	Operation enabled

- Notes**
1. Bit 6 (COI) is a read-only bit.
 2. Can be used freely as port function.
 3. Be sure to set WUP to 0 when the 2-wire serial I/O mode.
 4. When CSIE0=0, COI becomes 0.

Remark

- × : don't care
- PM_{xx} : Port mode register
- P_{xx} : Port output latch

(b) Serial bus interface control register (SBIC)

SBIC is set with a 1-bit or 8-bit memory manipulation instruction.

$\overline{\text{RESET}}$ input sets SBIC to 00H.

Symbol	<7>	<6>	<5>	<4>	<3>	<2>	<1>	<0>	Address	After Reset	R/W
SBIC	BSYE	ACKD	ACKE	ACKT	CMDD	RELD	CMDT	RELT	FF61H	00H	R/W

R/W	RELT	When RELT = 1, SO0 latch is set to 1. After SO0 latch setting, automatically cleared to 0. Also cleared to 0 when CSIE0 = 0.
-----	------	---

R/W	CMDT	When CMDT = 1, SO0 latch is cleared to 0. After SO0 latch clearance, automatically cleared to 0. Also cleared to 0 when CSIE0 = 0.
-----	------	---

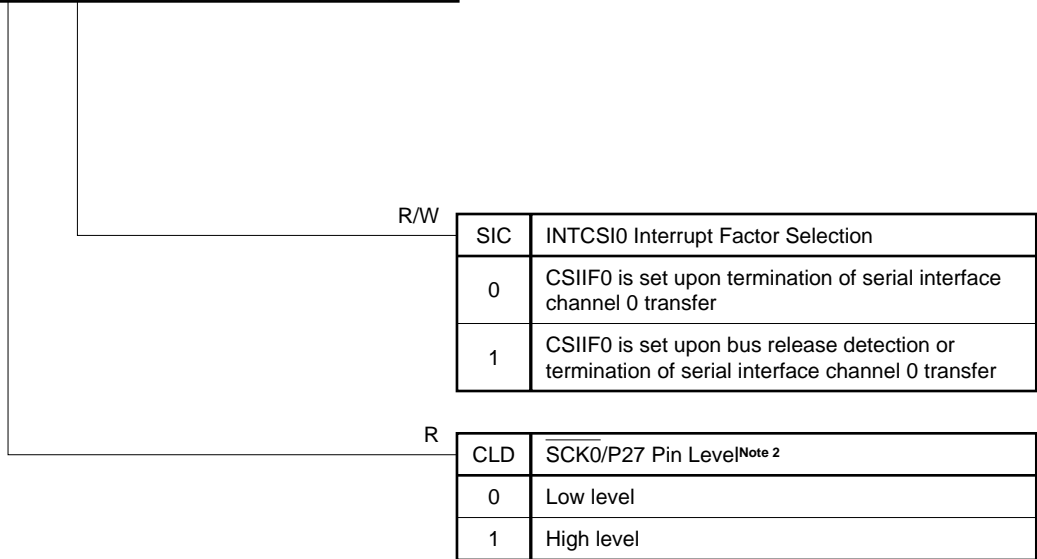
Remark CSIE0 : Bit 7 of serial operating mode register 0 (CSIM0)

(c) Interrupt timing specify register (SINT)

SINT is set with a 1-bit or 8-bit memory manipulation instruction.

RESET input sets SINT to 00H.

Symbol	7	<6>	<5>	<4>	3	2	1	0	Address	After Reset	R/W
SINT	0	CLD	SIC	SVAM	0	0	0	0	FF63H	00H	R/W ^{Note 1}



- Notes**
1. Bit 6 (CLD) is a read-only bit.
 2. When CSIE0 = 0, CLD becomes 0.

Caution Be sure to set bits 0 to 3 to 0.

Remark CSIF0 : Interrupt request flag corresponding to INTCSI0
 CSIE0 : Bit 7 of serial operating mode register 0 (CSIM0)

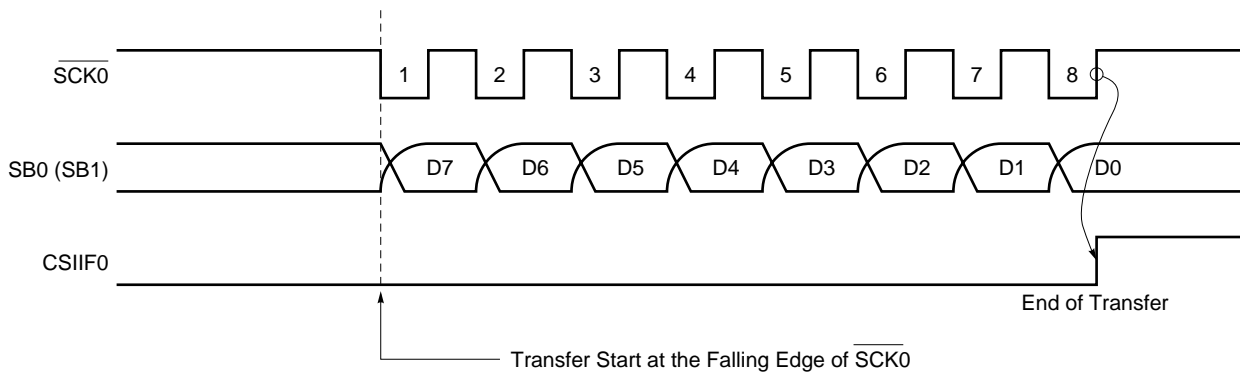
(2) Communication operation

The 2-wire serial I/O mode is used for data transmission/reception in 8-bit units. Data transmission/reception is carried out bit-wise in synchronization with the serial clock.

Shift operation of the serial I/O shift register 0 (SIO0) is carried out in synchronization with the falling edge of the serial clock ($\overline{\text{SCK0}}$). The transmit data is held in the SO0 latch and is output from the SB0/P25 (or SB1/P26) pin on an MSB-first basis. The receive data input from the SB0 (or SB1) pin is latched into the shift register at the rising edge of $\overline{\text{SCK0}}$.

Upon termination of 8-bit transfer, the shift register operation stops automatically and the interrupt request flag (CSIF0) is set.

Figure 16-32. 2-Wire Serial I/O Mode Timings



The SB0 (or SB1) pin specified for the serial data bus is an N-ch open-drain input/output and thus it must be externally connected to a pull-up resistor. Because it is necessary to set N-ch open-drain output to high-impedance state for data reception, write FFH to SIO0 in advance.

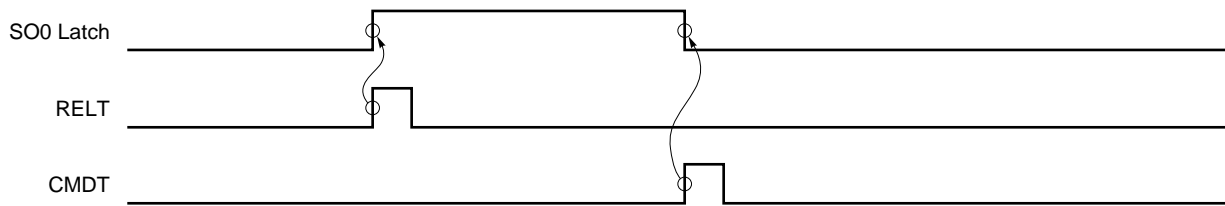
The SB0 (or SB1) pin generates the SO0 latch status and thus the SB0 (or SB1) pin output status can be manipulated by setting bit 0 (RELT) and bit 1 (CMDT) of serial bus interface control register (SBIC). However, do not carry out this manipulation during serial transfer.

Control the $\overline{\text{SCK0}}$ pin output level in the output mode (internal system clock mode) by manipulating the P27 output latch (refer to **16.4.5 $\overline{\text{SCK0}}$ /P27 pin output manipulation**).

(3) Other signals

Figure 16-33 shows RELT and CMDT operations.

Figure 16-33. RELT and CMDT Operations

**(4) Transfer start**

Serial transfer is started by setting transfer data to the serial I/O shift register 0 (SIO0) when the following two conditions are satisfied.

- Serial interface channel 0 operation control bit (CSIE0) = 1
- Internal serial clock is stopped or $\overline{\text{SCK0}}$ is at high level after 8-bit serial transfer.

Cautions 1. If CSIE0 is set to “1” after data write to SIO0, transfer does not start.

- 2. Because it is necessary to set N-ch open-drain output to high-impedance state for data reception, write FFH to SIO0 in advance.**

Upon termination of 8-bit transfer, serial transfer automatically stops and the interrupt request flag (CSIF0) is set.

(5) Error detection

In the 2-wire serial I/O mode, the serial bus SB0 (SB1) status being transmitted is fetched into the destination device, that is, serial I/O shift register 0 (SIO0). Thus, transmit error can be detected in the following way.

(a) Method of comparing SIO0 data before transmission to that after transmission

In this case, if two data differ from each other, a transmit error is judged to have occurred.

(b) Method of using the slave address register (SVA)

Transmit data is set to both SIO0 and SVA and is transmitted. After termination of transmission, COI bit (match signal coming from the address comparator) of the serial operating mode register 0 (CSIM0) is tested. If “1”, normal transmission is judged to have been carried out. If “0”, a transmit error is judged to have occurred.

16.4.5 $\overline{\text{SCK0/P27}}$ pin output manipulation

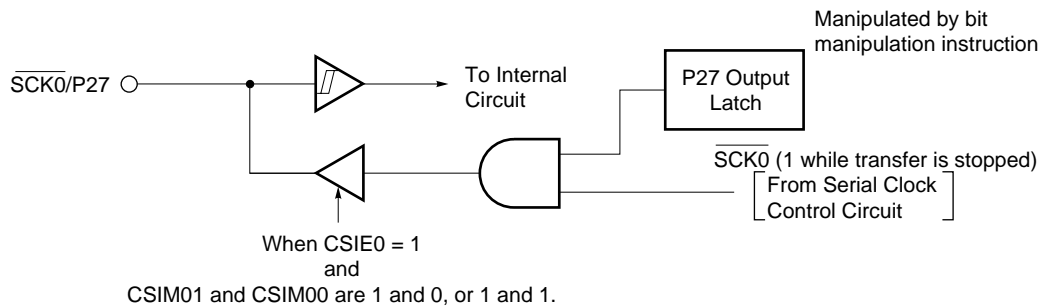
Because the $\overline{\text{SCK0/P27}}$ pin incorporates an output latch, static output is also possible by software in addition to normal serial clock output.

P27 output latch manipulation enables any value of $\overline{\text{SCK0}}$ to be set by software. (SI0/SB0 and SO0/SB1 pin to be controlled with the RELT and CMDT bits of serial bus interface control register (SBIC).)

$\overline{\text{SCK0/P27}}$ pin output manipulating procedure is described below.

- <1> Set the serial operating mode register 0 (CSIM0) ($\overline{\text{SCK0}}$ pin enabled for serial operation in the output mode).
 $\overline{\text{SCK0}} = 1$ with serial transfer suspended.
- <2> Manipulate the P27 output latch with a bit manipulation instruction.

Figure 16-34. $\overline{\text{SCK0/P27}}$ Pin Configuration



[MEMO]

CHAPTER 17 SERIAL INTERFACE CHANNEL 0 (μ PD78054Y Subseries)

The μ PD78054Y subseries incorporates three channels of serial interfaces. Differences between channels 0, 1, and 2 are as follows (Refer to **CHAPTER 18 SERIAL INTERFACE CHANNEL 1** for details of the serial interface channel 1. Refer to **CHAPTER 19 SERIAL INTERFACE CHANNEL 2** for details of the serial interface channel 2).

Table 17-1. Differences between Channels 0, 1, and 2

Serial Transfer Mode		Channel 0	Channel 1	Channel 2
3-wire serial I/O	Clock selection	$f_{xx}/2$, $f_{xx}/2^2$, $f_{xx}/2^3$, $f_{xx}/2^4$, $f_{xx}/2^5$, $f_{xx}/2^6$, $f_{xx}/2^7$, $f_{xx}/2^8$, external clock, TO2 output	$f_{xx}/2$, $f_{xx}/2^2$, $f_{xx}/2^3$, $f_{xx}/2^4$, $f_{xx}/2^5$, $f_{xx}/2^6$, $f_{xx}/2^7$, $f_{xx}/2^8$, external clock, TO2 output	Baud rate generator output
	Transfer method	MSB/LSB switchable as the start bit	MSB/LSB switchable as the start bit Automatic transmit/receive function	MSB/LSB switchable as the start bit
	Transfer end flag	Serial transfer end interrupt request flag (CSIIF0)	Serial transfer end interrupt request flag (CSIIF1)	Serial transfer end interrupt request flag (SRIF)
I ² C bus (Inter IC Bus)	2-wire serial I/O	Use possible	None	None
UART (Asynchronous serial interface)				None

17.1 Serial Interface Channel 0 Functions

Serial interface channel 0 employs the following four modes.

- Operation stop mode
- 3-wire serial I/O mode
- 2-wire serial I/O mode
- I²C (Inter IC) bus mode

Caution Do not switch the operation mode (3-wire serial I/O, 2-wire serial I/O, I²C bus) while the operation of serial interface channel 0 is enabled. Stop the serial operation before switching the operation mode.

(1) Operation stop mode

This mode is used when serial transfer is not carried out. Power consumption can be reduced.

(2) 3-wire serial I/O mode (MSB-/LSB-first selectable)

This mode is used for 8-bit data transfer using three lines, one each for serial clock ($\overline{\text{SCK0}}$), serial output (SO0) and serial input (SI0). This mode enables simultaneous transmission/reception and therefore reduces the data transfer processing time.

The start bit of transferred 8-bit data is switchable between MSB and LSB, so that devices can be connected regardless of their start bit recognition.

This mode should be used when connecting with peripheral I/O devices or display controllers which incorporate a conventional synchronous clocked serial interface as is the case with the 75X/XL, 78K, and 17K series.

(3) 2-wire serial I/O mode (MSB-first)

This mode is used for 8-bit data transfer using two lines of serial clock ($\overline{\text{SCK0}}$) and serial data bus (SB0 or SB1).

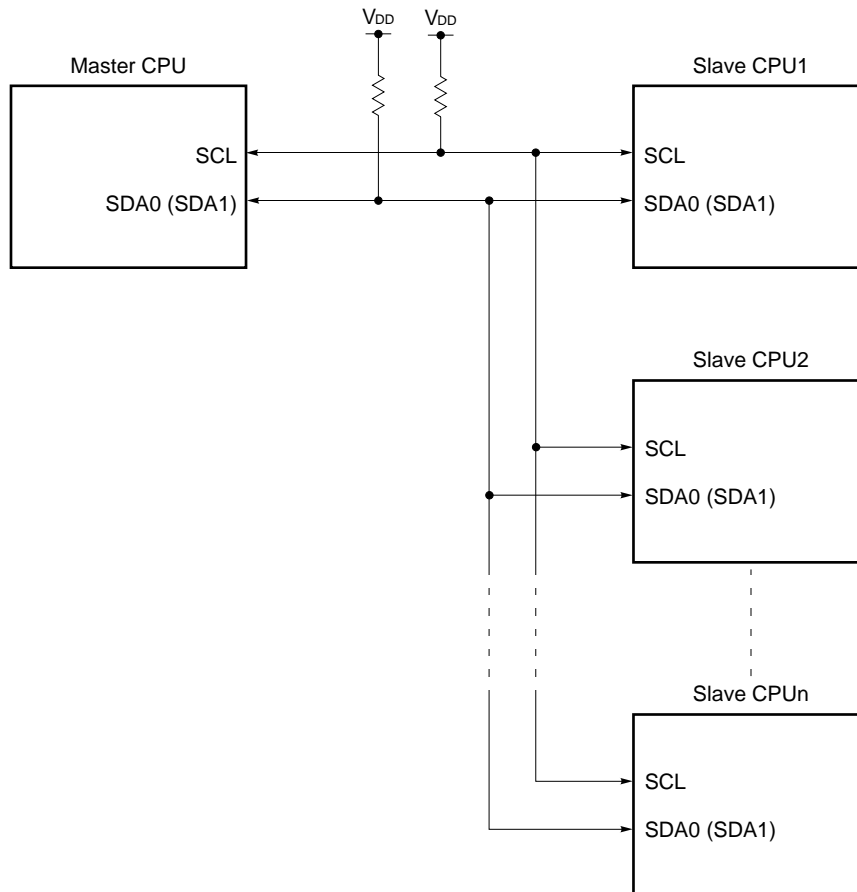
This mode enables to cope with any one of the possible data transfer formats by controlling the $\overline{\text{SCK0}}$ level and the SB0 or SB1 output level. Thus, the handshake line previously necessary for connection of two or more devices can be removed, resulting in the increased number of available input/output ports.

(4) I²C (Inter IC) bus mode (MSB-first)

This mode is used for 8-bit data transfer with two or more devices using two lines of serial clock (SCL) and serial data bus (SDA0 or SDA1).

This mode is in compliance with the I²C bus format. In this mode, the transmitter can output three kinds of data onto the serial data bus: “start condition”, “data”, and “stop condition”, to be actually sent or received. The receiver automatically distinguishes the received data into “start condition”, “data”, or “stop condition”, by hardware.

Figure 17-1. Serial Bus Configuration Example Using I²C Bus



17.2 Serial Interface Channel 0 Configuration

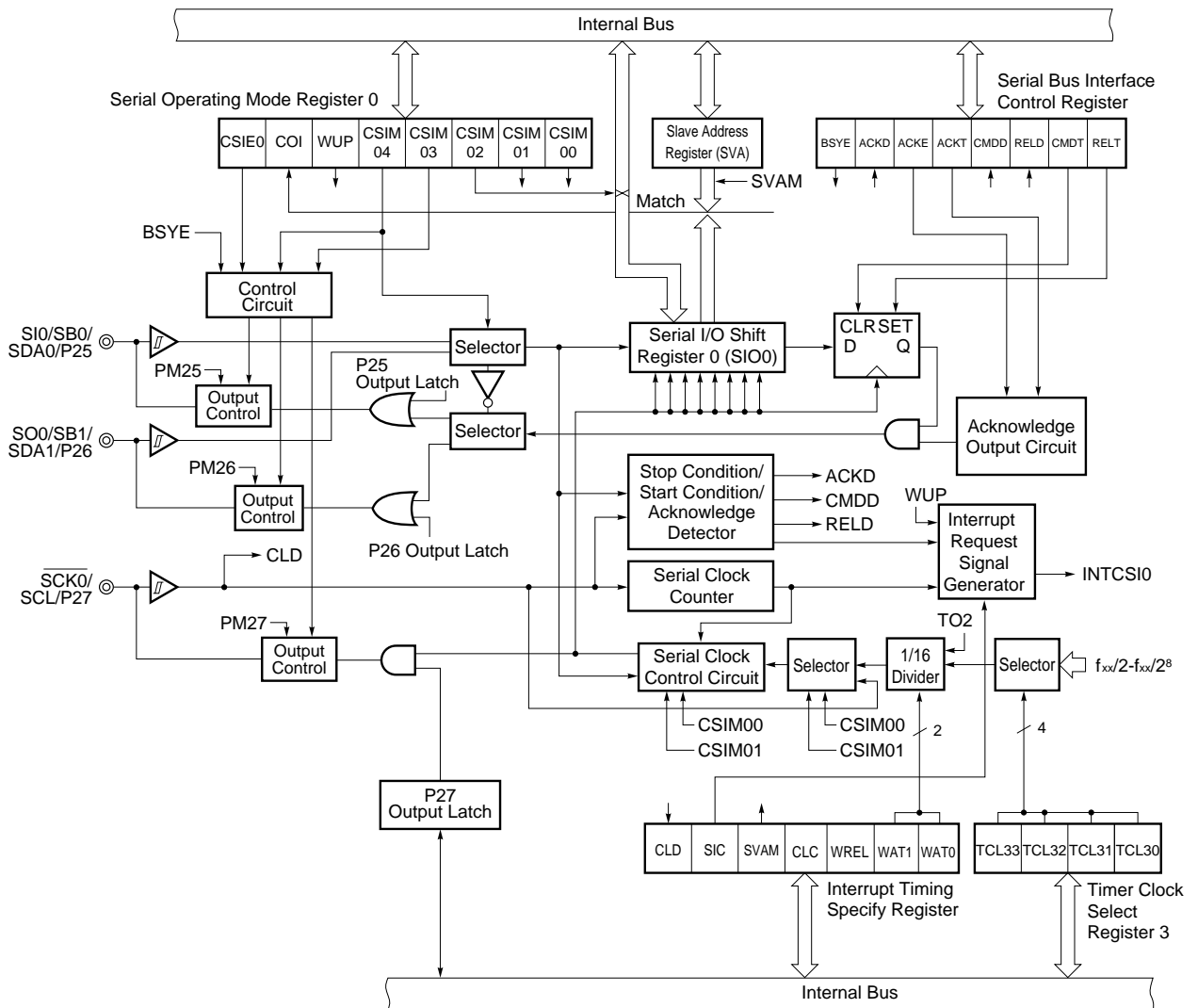
Serial interface channel 0 consists of the following hardware.

Table 17-2. Serial Interface Channel 0 Configuration

Item	Configuration
Register	Serial I/O shift register 0 (SIO0) Slave address register (SVA)
Control register	Timer clock select register 3 (TCL3) Serial operating mode register 0 (CSIM0) Serial bus interface control register (SBIC) Interrupt timing specify register (SINT) Port mode register 2 (PM2) ^{Note}

Note Refer to Figure 6-7. Block Diagram of P20, P21, P23 to P26 and Figure 6-8. Block Diagram of P22, P27.

Figure 17-2. Serial Interface Channel 0 Block Diagram



Remark Output Control selects between CMOS output and N-ch open drain output.

(1) Serial I/O shift register 0 (SIO0)

This is an 8-bit register to carry out parallel-serial conversion and to carry out serial transmission/reception (shift operation) in synchronization with the serial clock.

SIO0 is set with an 8-bit memory manipulation instruction.

When bit 7 (CSIE0) of serial operating mode register 0 (CSIM0) is 1, writing data to SIO0 starts serial operation. In transmission, data written to SIO0 is output to the serial output (SO0) or serial data bus (SB0/SB1). In reception, data is read from the serial input (SI0) or SB0/SB1 to SIO0.

Note that, if a bus is driven in the I²C bus mode or 2-wire serial I/O mode, the bus pin must serve for both input and output. Therefore, the transmission N-ch open-drain output of the device which will start reception of data must set to high impedance beforehand. Consequently, write FFH to SIO0 in advance.

In the I²C bus mode, set SIO0 to FFH with bit 7 (BSYE) of the serial bus interface control register (SBIC) set to 0.

$\overline{\text{RESET}}$ input makes SIO0 undefined.

Caution Do not execute an instruction that writes SIO0 in the I²C bus mode while WUP (bit 5 of the serial operating mode register 0 (CSIM0)) = 1. Even if such an instruction is not executed, data can be received when the wake-up function is used (WUP = 1). For the detail of the wake-up function, refer to 17.4.4 (1) (c) Wake-up function.

(2) Slave address register (SVA)

This is an 8-bit register to set the slave address value for connection of a slave device to the serial bus.

SVA is set with an 8-bit memory manipulation instruction. This register is not used in the 3-wire serial I/O mode. The master device outputs a slave address for selection of a particular slave device to the connected slave device. These two data (the slave address output from the master device and the SVA value) are compared with an address comparator. If they match, the slave device has been selected. In that case, bit 6 (COI) of serial operating mode register 0 (CSIM0) becomes 1.

Address comparison can also be executed on the data of LSB-masked high-order 7 bits by setting bit 4 (SVAM) of the interrupt timing specify register (SINT) to (1).

If no matching is detected in address reception, bit 2 (RELD) of the serial bus interface control register (SBIC) is cleared to 0. In the I²C bus mode, the wake-up function can be used by setting the bit 5 (WUP) of CSIM0. In this case, the interrupt request signal (INTCSI0) is generated when the slave address output by the master coincides with the value of SVA (the interrupt request signal is also generated when the stop condition is detected), and it can be learned by this interrupt request that the master requests for communication. To use the wake-up function, set SIC to 1.

Further, when SVA transmits data as master or slave device in the the I²C bus mode or 2-wire serial I/O mode, errors can be detected using SVA.

$\overline{\text{RESET}}$ input makes SVA undefined.

(3) SO0 latch

This latch holds SI0/SB0/SDA0/P25 and SO0/SB1/SDA1/P26 pin levels. It can be directly controlled by software.

(4) Serial clock counter

This counter counts the serial clocks to be output and input during transmission/reception and to check whether 8-bit data has been transmitted/received.

(5) Serial clock control circuit

This circuit controls serial clock supply to the serial I/O shift register 0 (SIO0). When the internal system clock is used, the circuit also controls clock output to the $\overline{\text{SCK0/SCL/P27}}$ pin.

(6) Interrupt request signal generator

This circuit controls interrupt request signal generation. It generates interrupt request signals according to the settings of interrupt timing specification register (SINT) bits 0 and 1 (WAT0, WAT1) and serial operation mode register 0 (CSIM0) bit 5 (WUP), as shown in Table 17-3.

(7) Acknowledge output circuit and stop condition/start condition/acknowledge detector

These two circuits output and detect various control signals in the I²C mode.

These do not operate in the 3-wire serial I/O mode and 2-wire serial I/O mode.

Table 17-3. Serial Interface Channel 0 Interrupt Request Signal Generation

Serial Transfer mode	BSYE	WUP	WAT1	WAT0	ACKE	Description
3-wire or 2-wire serial I/O mode	0	0	0	0	0	An interrupt request signal is generated each time 8 serial clocks are counted.
	Other than above					Setting prohibited
I ² C bus mode (transmit)	0	0	1	0	0	An interrupt request signal is generated each time 8 serial clocks are counted (8-clock wait). Normally, during transmission the settings WAT21, WAT0 = 1, 0, are not used. They are used only when wanting to coordinate receive time and processing systematically using software. ACK information is generated by the receiving side, thus ACKE should be set to 0 (disable).
			1	1	0	An interrupt request signal is generated each time 9 serial clocks are counted (9-clock wait). ACK information is generated by the receiving side, thus ACKE should be set to 0 (disable).
	Other than above					Setting prohibited
I ² C bus mode (receive)	1	0	1	0	0	An interrupt request signal is generated each time 8 serial clocks are counted (8-clock wait). ACK information is output by manipulating ACKT by software after an interrupt is generated.
			1	1	0/1	An interrupt request signal is generated each time 9 serial clocks are counted (9-clock wait). To automatically generate ACK information, preset ACKE to 1 before transfer start. However, in the case of the master, set ACKE to 0 (disable) before receiving the last data.
	1	1	1	1	1	After address is received, if the values of the serial I/O shift register 0 (SI00) and the slave address register (SVA) match, and if the stop condition is detected, an interrupt request signal is generated. To automatically generate ACK information, preset ACKE to 1 (enable) before transfer start.
	Other than above					Setting prohibited

Remark BSYE: Bit 7 of serial bus interface control register (SBIC)

ACKE: Bit 5 of serial bus interface control register (SBIC)

17.3 Serial Interface Channel 0 Control Registers

The following four types of registers are used to control serial interface channel 0.

- Timer clock select register 3 (TCL3)
- Serial operating mode register 0 (CSIM0)
- Serial bus interface control register (SBIC)
- Interrupt timing specify register (SINT)

(1) Timer clock select register 3 (TCL3)

This register sets the serial clock of serial interface channel 0.

TCL3 is set with an 8-bit memory manipulation instruction.

$\overline{\text{RESET}}$ input sets TCL3 to 88H.

Figure 17-3. Timer Clock Select Register 3 Format

Symbol	7	6	5	4	3	2	1	0	Address	After Reset	R/W
TCL3	TCL37	TCL36	TCL35	TCL34	TCL33	TCL32	TCL31	TCL30	FF43H	88H	R/W

TCL33				TCL32				TCL31				TCL30				Serial Interface Channel 0 Serial Clock Selection											
												Serial Clock in I ² C Bus Mode						Serial Clock in 2-Wire or 3-Wire Serial I/O Mode									
												MCS = 1			MCS = 0			MCS = 1			MCS = 0						
0	1	1	0	$f_{xx}/2^5$	Setting prohibited	$f_x/2^6$ (78.1 kHz)	$f_{xx}/2$	Setting prohibited	$f_x/2^2$ (1.25 MHz)																		
0	1	1	1	$f_{xx}/2^6$	$f_x/2^6$ (78.1 kHz)	$f_x/2^7$ (39.1 kHz)	$f_{xx}/2^2$	$f_x/2^2$ (1.25 MHz)	$f_x/2^3$ (625 kHz)																		
1	0	0	0	$f_{xx}/2^7$	$f_x/2^7$ (39.1 kHz)	$f_x/2^8$ (19.5 kHz)	$f_{xx}/2^3$	$f_x/2^3$ (625 kHz)	$f_x/2^4$ (313 kHz)																		
1	0	0	1	$f_{xx}/2^8$	$f_x/2^8$ (19.5 kHz)	$f_x/2^9$ (9.77 kHz)	$f_{xx}/2^4$	$f_x/2^4$ (313 kHz)	$f_x/2^5$ (156 kHz)																		
1	0	1	0	$f_{xx}/2^9$	$f_x/2^9$ (9.77 kHz)	$f_x/2^{10}$ (4.88 kHz)	$f_{xx}/2^5$	$f_x/2^5$ (156 kHz)	$f_x/2^6$ (78.1 kHz)																		
1	0	1	1	$f_{xx}/2^{10}$	$f_x/2^{10}$ (4.88 kHz)	$f_x/2^{11}$ (2.44 kHz)	$f_{xx}/2^6$	$f_x/2^6$ (78.1 kHz)	$f_x/2^7$ (39.1 kHz)																		
1	1	0	0	$f_{xx}/2^{11}$	$f_x/2^{11}$ (2.44 kHz)	$f_x/2^{12}$ (1.22 kHz)	$f_{xx}/2^7$	$f_x/2^7$ (39.1 kHz)	$f_x/2^8$ (19.5 kHz)																		
1	1	0	1	$f_{xx}/2^{12}$	$f_x/2^{12}$ (1.22 kHz)	$f_x/2^{13}$ (0.61 kHz)	$f_{xx}/2^8$	$f_x/2^8$ (19.5 kHz)	$f_x/2^9$ (9.8 kHz)																		
Other than above				Setting prohibited																							

TCL37				TCL36				TCL35				TCL34				Serial Interface Channel 1 Serial Clock Selection											
												MCS = 1						MCS = 0									
0	1	1	0	$f_{xx}/2$	Setting prohibited						$f_x/2^2$ (1.25 MHz)																
0	1	1	1	$f_{xx}/2^2$	$f_x/2^2$ (1.25 MHz)						$f_x/2^3$ (625 kHz)																
1	0	0	0	$f_{xx}/2^3$	$f_x/2^3$ (625 kHz)						$f_x/2^4$ (313 kHz)																
1	0	0	1	$f_{xx}/2^4$	$f_x/2^4$ (313 kHz)						$f_x/2^5$ (156 kHz)																
1	0	1	0	$f_{xx}/2^5$	$f_x/2^5$ (156 kHz)						$f_x/2^6$ (78.1 kHz)																
1	0	1	1	$f_{xx}/2^6$	$f_x/2^6$ (78.1 kHz)						$f_x/2^7$ (39.1 kHz)																
1	1	0	0	$f_{xx}/2^7$	$f_x/2^7$ (39.1 kHz)						$f_x/2^8$ (19.5 kHz)																
1	1	0	1	$f_{xx}/2^8$	$f_x/2^8$ (19.5 kHz)						$f_x/2^9$ (9.8 kHz)																
Other than above				Setting prohibited																							

Caution When rewriting TCL3 to other data, stop the serial transfer operation beforehand.

- Remarks**
1. f_{xx} : Main system clock frequency (f_x or $f_x/2$)
 2. f_x : Main system clock oscillation frequency
 3. MCS : Oscillation mode selection register (OSMS) bit 0
 4. Figures in parentheses apply to operation with $f_x = 5.0$ MHz.

(2) Serial operating mode register 0 (CSIM0)

This register sets serial interface channel 0 serial clock, operating mode, operation enable/stop wake-up function and displays the address comparator match signal.

CSIM0 is set with a 1-bit or 8-bit memory manipulation instruction.

$\overline{\text{RESET}}$ input sets CSIM0 to 00H.

Caution Do not switch the operation mode (3-wire serial I/O, 2-wire serial I/O, I²C bus) while the operation of serial interface channel 0 is enabled. Stop the serial operation before switching the operation mode.

Figure 17-4. Serial Operating Mode Register 0 Format

Symbol	<7>	<6>	<5>	4	3	2	1	0	Address	After Reset	R/W			
CSIM0	CSIE0	COI	WUP	CSIM04	CSIM03	CSIM02	CSIM01	CSIM00	FF60H	00H	R/W ^{Note 1}			
R/W	CSIM01	CSIM00	Serial Interface Channel 0 Clock Selection											
	0	×	Input Clock to $\overline{\text{SCK0/SCL}}$ pin from off-chip											
	1	0	8-bit timer register 2 (TM2) output ^{Note2}											
	1	1	Clock specified with bits 0 to 3 of timer clock select register 3 (TCL3)											
R/W	CSIM04	CSIM03	CSIM02	PM25	P25	PM26	P26	PM27	P27	Operation Mode	Start Bit	SI0/SB0/SDA0/ P25 Pin Function	SO0/SB1/SDA1/ P26 Pin Function	$\overline{\text{SCK0/SCL}}$ /P27 Pin Function
	0	×	0	^{Note3} 1	^{Note3} ×	0	0	0	1	3-wire serial I/O mode	MSB	SI0 ^{Note3} (Input)	SO0 (CMOS output)	$\overline{\text{SCK0}}$ (CMOS input/output)
			1					LSB						
	1	1	0	^{Note4} ×	^{Note4} ×	0	0	0	1	2-wire serial I/O mode or I ² C Bus Mode	MSB	P25 (CMOS input/output)	SB1/SDA1 (N-ch open-drain input/output)	$\overline{\text{SCK0/SCL}}$ (N-ch open- drain input/ output)
			1	0	0	^{Note4} ×	^{Note4} ×	0	1			SB0/SDA0 (N-ch open-drain input/output)	P26 (CMOS input/output)	
R/W	WUP	Wake-up Function Control ^{Note 5}												
	0	Interrupt request signal generation with each serial transfer in any mode												
	1	Interrupt request signal generation when the address received after detecting start condition (when CMDD = 1) matches the slave address register (SVA) data in I ² C bus mode												
R	COI	Slave Address Comparison Result Flag ^{Note 6}												
	0	Slave address register (SVA) not equal to serial I/O shift register 0 (SIO0) data												
	1	Slave address register (SVA) equal to serial I/O shift register 0 (SIO0) data												
R/W	CSIE0	Serial Interface Channel 0 Operation Control												
	0	Operation stopped												
	1	Operation enabled												

- Notes**
1. Bit 6 (COI) is a read-only bit.
 2. I²C bus mode, the clock frequency becomes 1/16 of that output from TO2.
 3. Can be used as P25 (CMOS input/output) when used only for transmission.
 4. Can be used freely as port function.
 5. To use the wake-up function (WUP = 1), set the bit 5 (SIC) of the interrupt timing specify register (SINT) to 1. Do not execute an instruction that writes the serial I/O shift register 0 (SIO0) while WUP = 1.
 6. When CSIE0 = 0, COI becomes 0.

Remark

- ×
- PM_{xx} : Port mode register
- P_{xx} : Port output latch

(3) Serial bus interface control register (SBIC)

This register sets serial bus interface operation and displays statuses.

SBIC is set with a 1-bit or 8-bit memory manipulation instruction.

$\overline{\text{RESET}}$ input sets SBIC to 00H.

Figure 17-5. Serial Bus Interface Control Register Format (1/2)

Symbol	<7>	<6>	<5>	<4>	<3>	<2>	<1>	<0>	Address	After Reset	R/W																										
SBIC	BSYE	ACKD	ACKE	ACKT	CMDD	RELD	CMDT	RELT	FF61H	00H	R/W ^{Note}																										
R/W	<table border="1"> <tr> <td>RELT</td> <td>Used for stop condition signal output. When RELT = 1, SO0 latch is set to 1. After SO0 latch setting, automatically cleared to 0. Also cleared to 0 when CSIE0 = 0.</td> </tr> </table>											RELT	Used for stop condition signal output. When RELT = 1, SO0 latch is set to 1. After SO0 latch setting, automatically cleared to 0. Also cleared to 0 when CSIE0 = 0.																								
RELT	Used for stop condition signal output. When RELT = 1, SO0 latch is set to 1. After SO0 latch setting, automatically cleared to 0. Also cleared to 0 when CSIE0 = 0.																																				
R/W	<table border="1"> <tr> <td>CMDT</td> <td>Used for start condition signal output. When CMDT = 1, SO0 latch is cleared to (0). After SO0 latch clearance, automatically cleared to 0. Also cleared to 0 when CSIE0 = 0.</td> </tr> </table>											CMDT	Used for start condition signal output. When CMDT = 1, SO0 latch is cleared to (0). After SO0 latch clearance, automatically cleared to 0. Also cleared to 0 when CSIE0 = 0.																								
CMDT	Used for start condition signal output. When CMDT = 1, SO0 latch is cleared to (0). After SO0 latch clearance, automatically cleared to 0. Also cleared to 0 when CSIE0 = 0.																																				
R	<table border="1"> <tr> <td>RELD</td> <td>Stop Condition Detection</td> </tr> <tr> <td colspan="5">Clear Conditions (RELD = 0)</td> <td colspan="7">Set Conditions (RELD = 1)</td> </tr> <tr> <td colspan="5"> <ul style="list-style-type: none"> • When transfer start instruction is executed • If SIO0 and SVA values do not match in address reception • When CSIE0 = 0 • When $\overline{\text{RESET}}$ input is applied </td> <td colspan="7"> <ul style="list-style-type: none"> • When stop condition signal is detected </td> </tr> </table>											RELD	Stop Condition Detection	Clear Conditions (RELD = 0)					Set Conditions (RELD = 1)							<ul style="list-style-type: none"> • When transfer start instruction is executed • If SIO0 and SVA values do not match in address reception • When CSIE0 = 0 • When $\overline{\text{RESET}}$ input is applied 					<ul style="list-style-type: none"> • When stop condition signal is detected 						
RELD	Stop Condition Detection																																				
Clear Conditions (RELD = 0)					Set Conditions (RELD = 1)																																
<ul style="list-style-type: none"> • When transfer start instruction is executed • If SIO0 and SVA values do not match in address reception • When CSIE0 = 0 • When $\overline{\text{RESET}}$ input is applied 					<ul style="list-style-type: none"> • When stop condition signal is detected 																																
R	<table border="1"> <tr> <td>CMDD</td> <td>Start Condition Detection</td> </tr> <tr> <td colspan="5">Clear Conditions (CMDD = 0)</td> <td colspan="7">Set Conditions (CMDD = 1)</td> </tr> <tr> <td colspan="5"> <ul style="list-style-type: none"> • When transfer start instruction is executed • When stop condition signal is detected • When CSIE0 = 0 • When $\overline{\text{RESET}}$ input is applied </td> <td colspan="7"> <ul style="list-style-type: none"> • When start condition signal is detected </td> </tr> </table>											CMDD	Start Condition Detection	Clear Conditions (CMDD = 0)					Set Conditions (CMDD = 1)							<ul style="list-style-type: none"> • When transfer start instruction is executed • When stop condition signal is detected • When CSIE0 = 0 • When $\overline{\text{RESET}}$ input is applied 					<ul style="list-style-type: none"> • When start condition signal is detected 						
CMDD	Start Condition Detection																																				
Clear Conditions (CMDD = 0)					Set Conditions (CMDD = 1)																																
<ul style="list-style-type: none"> • When transfer start instruction is executed • When stop condition signal is detected • When CSIE0 = 0 • When $\overline{\text{RESET}}$ input is applied 					<ul style="list-style-type: none"> • When start condition signal is detected 																																
R/W	<table border="1"> <tr> <td>ACKT</td> <td>Used to generate the $\overline{\text{ACK}}$ signal by software when 8-clock wait mode is selected. Keeps SDA0 (SDA1) low from set instruction (ACKT=1) execution to the next falling edge of SCL. Also cleared to 0 upon start of serial interface transfer or when CSIE0 = 0.</td> </tr> </table>											ACKT	Used to generate the $\overline{\text{ACK}}$ signal by software when 8-clock wait mode is selected. Keeps SDA0 (SDA1) low from set instruction (ACKT=1) execution to the next falling edge of SCL. Also cleared to 0 upon start of serial interface transfer or when CSIE0 = 0.																								
ACKT	Used to generate the $\overline{\text{ACK}}$ signal by software when 8-clock wait mode is selected. Keeps SDA0 (SDA1) low from set instruction (ACKT=1) execution to the next falling edge of SCL. Also cleared to 0 upon start of serial interface transfer or when CSIE0 = 0.																																				

Note Bits 2, 3, and 6 (RELD, CMDD and ACKD) are read-only bits.

Remarks 1. Bits 0, 1, and 4 (RELT, CMDT, ACKT) are 0 when read after the data is set.
2. CSIE0: Bit 7 of serial operating mode register 0 (CSIM0)

Figure 17-5. Serial Bus Interface Control Register Format (2/2)

R/W	ACKE	Acknowledge Signal Output Control ^{Note 1}	
	0	Disables acknowledge signal automatic output. (However, output with ACKT is enabled) Used for reception when 8-clock wait mode is selected or for transmission. ^{Note 2}	
	1	Enables acknowledge signal automatic output. Outputs acknowledge signal in synchronization with the falling edge of the 9th SCL clock cycle (automatically output when ACKE = 1). However, not automatically cleared to 0 after acknowledge signal output. Used in reception with 9-clock wait mode selected.	
R	ACKD	Acknowledge Detection	
		Clear Conditions (ACKD = 0)	Set Conditions (ACKD = 1)
		<ul style="list-style-type: none"> • While executing the transfer start instruction • When CSIE0 = 0 • When $\overline{\text{RESET}}$ input is applied 	<ul style="list-style-type: none"> • When acknowledge signal ($\overline{\text{ACK}}$) is detected at the rising edge of SCL clock after completion of transfer
R/W	^{Note 3} BSYE	Control of N-ch Open-Drain Output for Transmission in I ² C Bus Mode ^{Note 4}	
	0	Output enabled (transmission)	
	1	Output disabled (reception)	

- Notes**
1. Setting should be performed before transfer.
 2. If 8-clock wait mode is selected, the acknowledge signal at reception time must be output using ACKT.
 3. The busy mode can be canceled by start of serial interface transfer or reception of address signal. However, the BSYE flag is not cleared to 0.
 4. When using the wake-up function, be sure to set BSYE to 1.

Remark CSIE0: Bit 7 of serial operating mode register 0 (CSIM0)

(4) Interrupt timing specify register (SINT)

This register sets the bus release interrupt and address mask functions and displays the $\overline{SCK0/SCL}$ pin level status. SINT is set with a 1-bit or 8-bit memory manipulation instruction. \overline{RESET} input sets SINT to 00H.

Figure 17-6. Interrupt Timing Specify Register Format (1/2)

Symbol	7	<6>	<5>	<4>	<3>	<2>	1	0	Address	After Reset	R/W
SINT	0	CLD	SIC	SVAM	CLC	WREL	WAT1	WAT0	FF63H	00H	R/W ^{Note 1}

R/W	WAT1	WAT0	Wait and Interrupt Control
	0	0	Generates interrupt service request at rising edge of 8th $\overline{SCK0}$ clock cycle. (keeping clock output in high impedance)
	0	1	Setting prohibited
	1	0	Used in I ² C bus mode. (8-clock wait) Generates interrupt service request at rising edge of 8th SCK0 clock cycle. (In the case of master device, makes SCL output low to enter wait state after 8 clock pulses are output. In the case of slave device, makes SCL output low to request wait state after 8 clock pulses are input.)
	1	1	Used in I ² C bus mode. (9-clock wait) Generates interrupt service request at rising edge of 9th SCK0 clock cycle. (In the case of master device, makes SCL output low to enter wait state after 9 clock pulses are output. In the case of slave device, makes SCL output low to request wait state after 9 clock pulses are input.)

R/W	WREL	Wait State Cancellation Control
	0	Wait state has been cancelled.
	1	Cancels wait state. Automatically cleared to 0 when the state is cancelled. (Used to cancel wait state by means of WAT0 and WAT1.)

R/W	CLC	Clock Level Control ^{Note 2}
	0	Used in I ² C bus mode. Make output level of SCL pin low unless serial transfer is being performed.
	1	Used in I ² C bus mode. Make SCL pin enter high-impedance state unless serial transfer is being performed. (except for clock line which is kept high) Used to enable master device to generate start condition and stop condition signals.

- Notes**
1. Bit 6 (CLD) is a read-only bit.
 2. When not using the I²C mode, set CLC to 0.

Figure 17-6. Interrupt Timing Specify Register Format (2/2)

R/W	SVAM	SVA Bit to be Used as Slave Address
	0	Bits 0 to 7
	1	Bits 1 to 7
R/W	SIC	INTCSI0 Interrupt Cause Selection ^{Note 1}
	0	CSIIF0 is set to 1 upon termination of serial interface channel 0 transfer
	1	CSIIF0 is set to 1 upon stop condition detection or termination of serial interface channel 0 transfer
R	CLD	$\overline{\text{SCK0/SCL}}$ Pin Level ^{Note 2}
	0	Low level
	1	High level

- Notes**
1. When using wake-up function in the I²C mode, set SIC to 0.
 2. When CSIE0 = 0, CLD becomes 0.

Remark

- SVA : Slave address register
- CSIIF0 : Interrupt request flag corresponding to INTCSI0
- CSIE0 : Bit 7 of serial operating mode register 0 (CSIM0)

17.4 Serial Interface Channel 0 Operations

The following four operating modes are available to the serial interface channel 0.

- Operation stop mode
- 3-wire serial I/O mode
- 2-wire serial I/O mode
- I²C (Inter IC) bus mode

17.4.1 Operation stop mode

Serial transfer is not carried out in the operation stop mode. Thus, power consumption can be reduced. The serial I/O shift register 0 (SIO0) does not carry out shift operation either and thus it can be used as ordinary 8-bit register.

In the operation stop mode, the P25/SI0/SB0/SDA0, P26/SO0/SB1/SDA1 and P27/ $\overline{\text{SCK0}}$ /SCL pins can be used as general input/output ports.

(1) Register setting

The operation stop mode is set with the serial operating mode register 0 (CSIM0).

CSIM0 is set with a 1-bit or 8-bit memory manipulation instruction.

$\overline{\text{RESET}}$ input sets CSIM0 to 00H.

Symbol	<7>	<6>	<5>	4	3	2	1	0	Address	After Reset	R/W
CSIM0	CSIE0	COI	WUP	CSIM04	CSIM03	CSIM02	CSIM01	CSIM00	FF60H	00H	R/W

R/W	CSIE0	Serial Interface Channel 0 Operation Control
0		Operation stopped
1		Operation enabled

17.4.2 3-wire serial I/O mode operation

The 3-wire serial I/O mode is valid for connection of peripheral I/O units and display controllers which incorporate a conventional synchronous clocked serial interface as is the case with the 75X/XL, 78K, and 17K series.

Communication is carried out with three lines of serial clock ($\overline{\text{SCK0}}$), serial output (SO0), and serial input (SI0).

(1) Register setting

The 3-wire serial I/O mode is set with the serial operating mode register 0 (CSIM0) and serial bus interface control register (SBIC).

(a) Serial operating mode register 0 (CSIM0)

CSIM0 is set with a 1-bit or 8-bit memory manipulation instruction.

$\overline{\text{RESET}}$ input sets CSIM0 to 00H.

Symbol	<7>	<6>	<5>	4	3	2	1	0	Address	After Reset	R/W
CSIM0	CSIE0	COI	WUP	CSIM04	CSIM03	CSIM02	CSIM01	CSIM00	FF60H	00H	R/W ^{Note 1}

R/W	CSIM01	CSIM00	Serial Interface Channel 0 Clock Selection
	0	×	Input Clock to $\overline{\text{SCK0}}$ pin from off-chip
	1	0	8-bit timer register 2 (TM2) output
	1	1	Clock specified with bits 0 to 3 of timer clock select register 3 (TCL3)

R/W	CSIM04	CSIM03	CSIM02	PM25	P25	PM26	P26	PM27	P27	Operation Mode	Start Bit	SIO/SB0/SDA0 /P25 Pin Function	SO0/SB1/SDA1 /P26 Pin Function	$\overline{\text{SCK0}}$ /SCL/P27 Pin Function
	0	×	0	^{Note 2} 1	^{Note 2} ×	0	0	0	1	3-wire serial I/O mode	MSB	SI0 ^{Note 2} (Input)	SO0 (CMOS output)	$\overline{\text{SCK0}}$ (CMOS input/output)
	1	1	2-wire serial I/O mode (See the section 17.4.3, "2-wire serial I/O mode operation".) or I ² C bus mode (See the section 17.4.4, "I ² C bus mode operation".)											

R/W	WUP	Wake-up Function Control ^{Note 3}
	0	Interrupt request signal generation with each serial transfer in any mode
	1	Interrupt request signal generation when the address received after detecting start condition (when CMDD = 1) matches the slave address register (SVA) data in I ² C bus mode

R/W	CSIE0	Serial Interface Channel 0 Operation Control
	0	Operation stopped
	1	Operation enabled

- Notes**
1. Bit 6 (COI) is a read-only bit.
 2. Can be used as P25 (CMOS input/output) when used only for transmission.
 3. Be sure to set WUP to 0 when the 3-wire serial I/O mode is selected.

Remark

- ×
- PM_{xx} : Port mode register
- P_{xx} : Port output latch

(b) Serial bus interface control register (SBIC)

SBIC is set with a 1-bit or 8-bit memory manipulation instruction.

$\overline{\text{RESET}}$ input sets SBIC to 00H.

Symbol	<7>	<6>	<5>	<4>	<3>	<2>	<1>	<0>	Address	After Reset	R/W
SBIC	BSYE	ACKD	ACKE	ACKT	CMDD	RELD	CMDT	RELT	FF61H	00H	R/W

R/W	RELT	When RELT = 1, SO0 latch is set to 1. After SO0 latch setting, automatically cleared to 0. Also cleared to 0 when CSIE0 = 0.
-----	------	--

R/W	CMDT	When CMDT = 1, SO0 latch is cleared to 0. After SO0 latch clearance, automatically cleared to 0. Also cleared to 0 when CSIE0 = 0.
-----	------	--

Remark CSIE0: Bit 7 of serial operating mode register 0 (CSIM0)

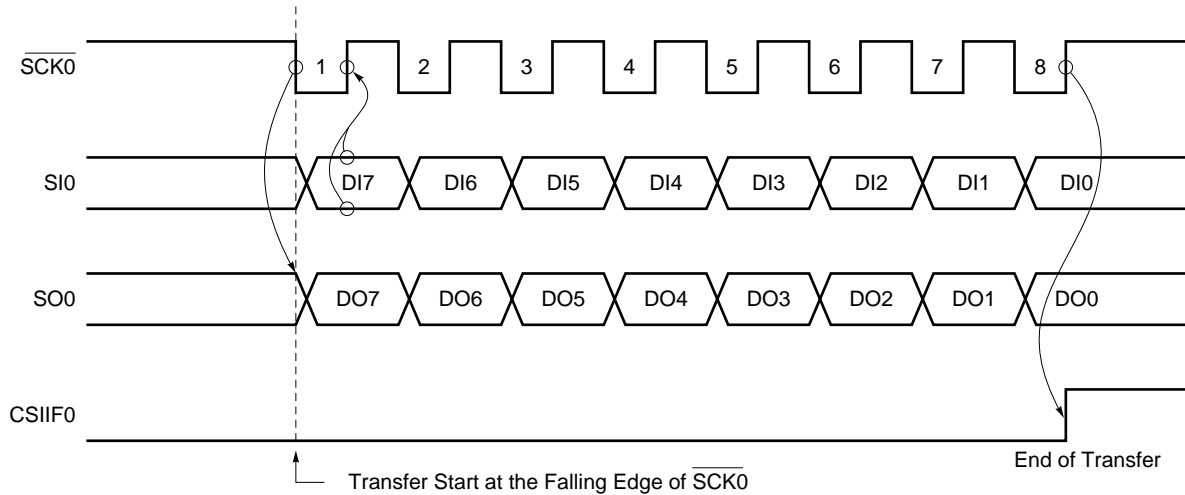
(2) Communication operation

The 3-wire serial I/O mode is used for data transmission/reception in 8-bit units. Bit-wise data transmission/reception is carried out in synchronization with the serial clock.

Shift operation of the serial I/O shift register 0 (SIO0) is carried out at the falling edge of the serial clock ($\overline{\text{SCK0}}$). The transmitted data is held in the SO0 latch and is output from the SO0 pin. The received data input to the SIO pin is latched in SIO0 at the rising edge of $\overline{\text{SCK0}}$.

Upon termination of 8-bit transfer, SIO0 operation stops automatically and the interrupt request flag (CSIF0) is set.

Figure 17-7. 3-Wire Serial I/O Mode Timings



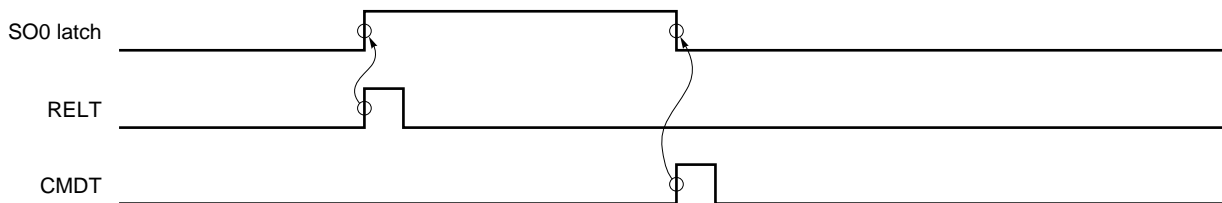
The SO0 pin is a CMOS output pin and outputs current SO0 latch statuses. Thus, the SO0 pin output status can be manipulated by setting bit 0 (RELT) and bit 1 (CMDT) of serial bus interface control register (SBIC). However, do not carry out this manipulation during serial transfer.

Control the $\overline{\text{SCK0}}$ pin output level in the output mode (internal system clock mode) by manipulating the P27 output latch (refer to 17.4.7 $\overline{\text{SCK0/SCL/P27}}$ pin output manipulation).

(3) Other signals

Figure 17-8 shows RELT and CMDT operations.

Figure 17-8. RELT and CMDT Operations

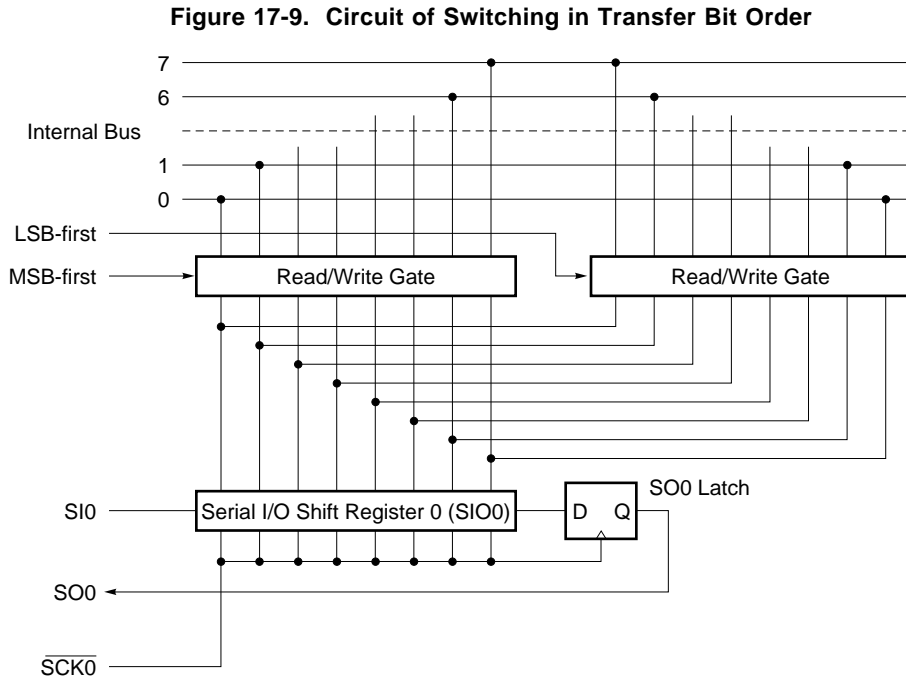


(4) MSB/LSB switching as the start bit

The 3-wire serial I/O mode enables to select transfer to start from MSB or LSB.

Figure 17-9 shows the configuration of the serial I/O shift register 0 (SIO0) and internal bus. As shown in the figure, MSB/LSB can be read/written in reverse form.

MSB/LSB switching as the start bit can be specified with bit 2 (CSIM02) of the serial operating mode register 0 (CSIM0).



Start bit switching is realized by switching the bit order for data write to SIO0. The SIO0 shift order remains unchanged.

Thus, switching between MSB-first and LSB-first must be performed before writing data to SIO0.

(5) Transfer start

Serial transfer is started by setting transfer data to the serial I/O shift register 0 (SIO0) when the following two conditions are satisfied.

- Serial interface channel 0 operation control bit (CSIE0) = 1.
- Internal serial clock is stopped or $\overline{\text{SCK0}}$ is a high level after 8-bit serial transfer.

Caution If CSIE0 is set to "1" after data write to SIO0, transfer does not start.

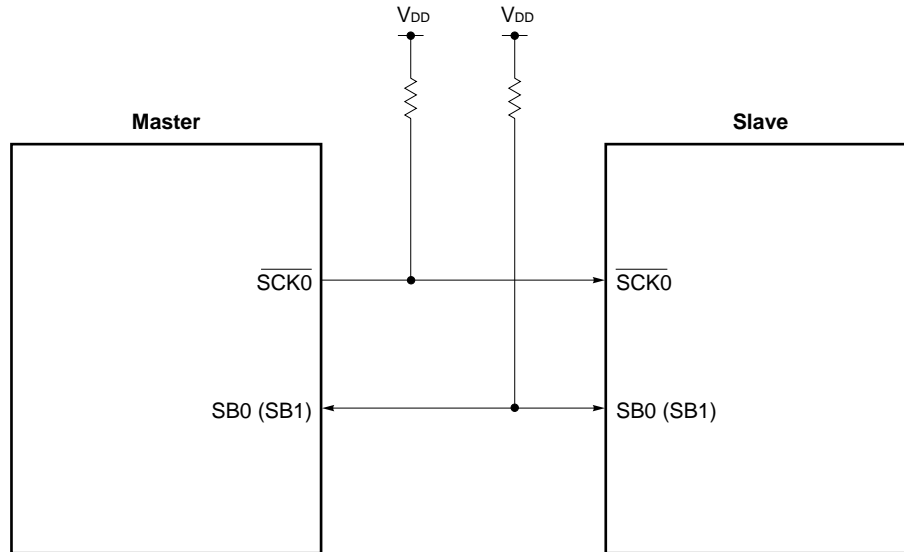
Upon termination of 8-bit transfer, serial transfer automatically stops and the interrupt request flag (CSIF0) is set.

17.4.3 2-wire serial I/O mode operation

The 2-wire serial I/O mode can cope with any communication format by program.

Communication is basically carried out with two lines of serial clock ($\overline{\text{SCK0}}$) and serial data input/output (SB0 or SB1).

Figure 17-10. Serial Bus Configuration Example Using 2-Wire Serial I/O Mode



(1) Register setting

The 2-wire serial I/O mode is set with the serial operating mode register 0 (CSIM0), the serial bus interface control register (SBIC), and the interrupt timing specify register (SINT).

(a) Serial operating mode register 0 (CSIM0)

CSIM0 is set with a 1-bit or 8-bit memory manipulation instruction.

RESET input sets CSIM0 to 00H.

Symbol	<7>	<6>	<5>	4	3	2	1	0	Address	After Reset	R/W
CSIM0	CSIE0	COI	WUP	CSIM04	CSIM03	CSIM02	CSIM01	CSIM00	FF60H	00H	R/W ^{Note 1}

R/W	CSIM01	CSIM00	Serial Interface Channel 0 Clock Selection
	0	×	Input Clock to SCK0 pin from off-chip
	1	0	8-bit timer register 2 (TM2) output
	1	1	Clock specified with bits 0 to 3 of timer clock select register 3 (TCL3)

R/W	CSIM04	CSIM03	CSIM02	PM25	P25	PM26	P26	PM27	P27	Operation Mode	Start Bit	SIO/SB0/SDA0 /P25 Pin Function	SO0/SB1/SDA1 /P26 Pin Function	SCK0/SCL/P27 Pin Function		
	0	×	3-wire Serial I/O mode (See Section 17.4.2, "3-wire serial I/O mode operation")													
	1	1	0	Note 2	Note 2	×	×	0	0	0	1	2-wire serial I/O mode or I ² C bus mode	MSB	P25 (CMOS input/output)	SB1/SDA1 (N-ch open-drain input/output)	SCK0/SCL (N-ch open-drain input/output)
			1	0	0	Note 2	Note 2	×	×	0	1			SB0/SDA0 (N-ch open-drain input/output)	P26 (CMOS input/output)	

R/W	WUP	Wake-up Function Control ^{Note 3}
	0	Interrupt request signal generation with each serial transfer in any mode
	1	Interrupt request signal generation when the address received after detecting start condition (when CMDD = 1) matches the slave address register (SVA) data in I ² C bus mode

R	COI	Slave Address Comparison Result Flag ^{Note 4}
	0	Slave address register (SVA) not equal to serial I/O shift register 0 (SIO0) data
	1	Slave address register (SVA) equal to serial I/O shift register 0 (SIO0) data

R/W	CSIE0	Serial Interface Channel 0 Operation Control
	0	Operation stopped
	1	Operation enabled

- Notes**
1. Bit 6 (COI) is a read-only bit.
 2. Can be used freely as port function.
 3. Be sure to set WUP to 0 when the 2-wire serial I/O mode.
 4. When CSIE0=0, COI becomes 0.

Remark

- ×
- PM_{xx} : Port mode register
- P_{xx} : Port output latch

(b) Serial bus interface control register (SBIC)

SBIC is set with a 1-bit or 8-bit memory manipulation instruction.

$\overline{\text{RESET}}$ input sets SBIC to 00H.

Symbol	<7>	<6>	<5>	<4>	<3>	<2>	<1>	<0>	Address	After Reset	R/W
SBIC	BSYE	ACKD	ACKE	ACKT	CMD D	RELD	CMDT	RELT	FF61H	00H	R/W

R/W	RELT	When RELT = 1, SO0 latch is set to 1. After SO0 latch setting, automatically cleared to 0. Also cleared to 0 when CSIE0 = 0.
-----	------	--

R/W	CMDT	When CMDT = 1, SO0 latch is cleared to 0. After SO0 latch clearance, automatically cleared to 0. Also cleared to 0 when CSIE0 = 0.
-----	------	--

Remark CSIE0: Bit 7 of serial operating mode register 0 (CSIM0)

(c) Interrupt timing specify register (SINT)

SINT is set with a 1-bit or 8-bit memory manipulation instruction.

$\overline{\text{RESET}}$ input sets SINT to 00H.

Symbol	7	<6>	<5>	<4>	<3>	<2>	1	0	Address	After Reset	R/W
SINT	0	CLD	SIC	SVAM	CLC	WREL	WAT1	WAT0	FF63H	00H	R/W ^{Note 1}

R/W	SIC	INTCSI0 Interrupt Factor Selection
	0	CSIIF0 is set upon termination of serial interface channel 0 transfer
	1	CSIIF0 is set upon bus release detection or termination of serial interface channel 0 transfer

R	CLD	SCK0 Pin Level ^{Note 2}
	0	Low level
	1	High level

- Notes**
1. Bit 6 (CLD) is a read-only bit.
 2. When CSIE0 = 0, CLD becomes 0.

Caution Be sure to set bits 0 to 3 to 0 in the 2-wire serial I/O mode is used.

Remark CSIIF0 : Interrupt request flag corresponding to INTCSI0
 CSIE0 : Bit 7 of serial operating mode register 0 (CSIM0)

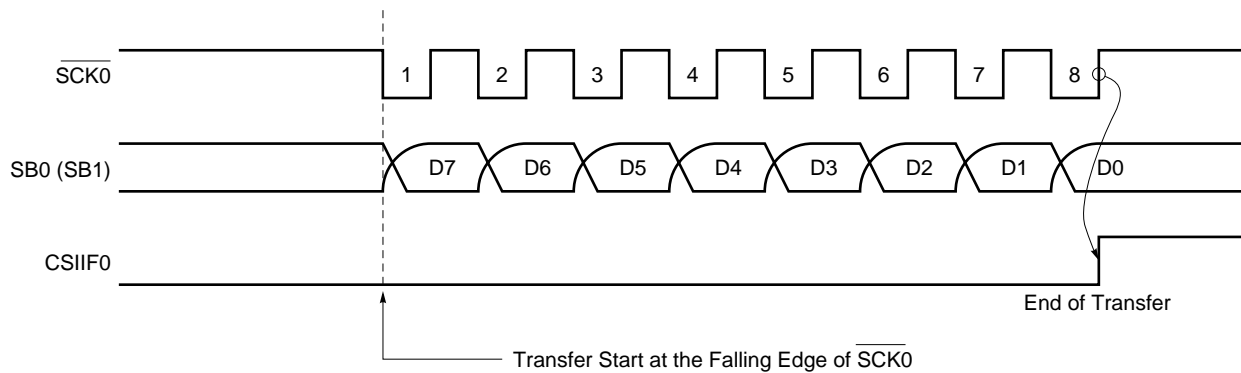
(2) Communication operation

The 2-wire serial I/O mode is used for data transmission/reception in 8-bit units. Data transmission/reception is carried out bit-wise in synchronization with the serial clock.

Shift operation of the serial I/O shift register 0 (SIO0) is carried out in synchronization with the falling edge of the serial clock ($\overline{\text{SCK0}}$). The transmit data is held in the SO0 latch and is output from the SB0/SDA0/P25 (or SB1/SDA1/P26) pin on an MSB-first basis. The receive data input from the SB0 (or SB1) pin is latched into the shift register at the rising edge of $\overline{\text{SCK0}}$.

Upon termination of 8-bit transfer, the shift register operation stops automatically and the interrupt request flag (CSIIF0) is set.

Figure 17-11. 2-Wire Serial I/O Mode Timings



The SB0 (or SB1) pin specified for the serial data bus is an N-ch open-drain input/output and thus it must be externally connected to a pull-up resistor. Because it is necessary to set the N-ch open-drain output to high impedance for data reception, write FFH to SIO0 in advance.

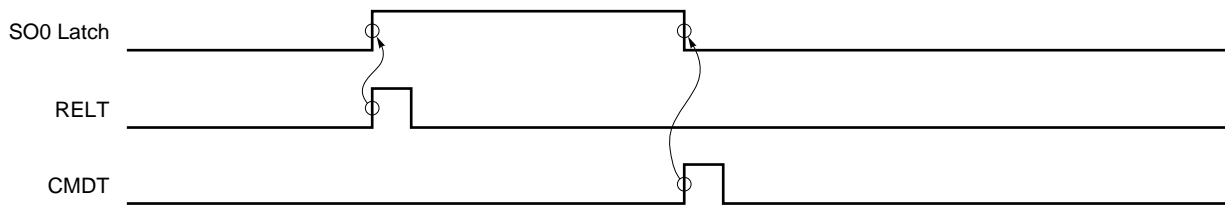
The SB0 (or SB1) pin generates the SO0 latch status and thus the SB0 (or SB1) pin output status can be manipulated by setting bit 0 (RELT) and bit 1 (CMDT) of serial bus interface control register (SBIC). However, do not carry out this manipulation during serial transfer.

Control the $\overline{\text{SCK0}}$ pin output level in the output mode (internal system clock mode) by manipulating the P27 output latch (refer to **17.4.7 $\overline{\text{SCK0/SCL/P27}}$ pin output manipulation**).

(3) Other signals

Figure 17-12 shows RELT and CMDT operations.

Figure 17-12. RELT and CMDT Operations

**(4) Transfer start**

Serial transfer is started by setting transfer data to the serial I/O shift register 0 (SIO0) when the following two conditions are satisfied.

- Serial interface channel 0 operation control bit (CSIE0) = 1
- Internal serial clock is stopped or $\overline{\text{SCK0}}$ is at high level after 8-bit serial transfer.

Cautions 1. If CSIE0 is set to “1” after data write to SIO0, transfer does not start.

- 2. Because the N-ch open-drain output must be set to high-impedance state for data reception, write FFH to SIO0 in advance.**

Upon termination of 8-bit transfer, serial transfer automatically stops and the interrupt request flag (CSIF0) is set.

(5) Error detection

In the 2-wire serial I/O mode, the serial bus SB0 (SB1) status being transmitted is fetched into the destination device, that is, serial I/O shift register 0 (SIO0). Thus, transmit error can be detected in the following way.

(a) Method of comparing SIO0 data before transmission to that after transmission

In this case, if two data differ from each other, a transmit error is judged to have occurred.

(b) Method of using the slave address register (SVA)

Transmit data is set to both SIO0 and SVA and is transmitted. After termination of transmission, COI bit (match signal coming from the address comparator) of the serial operating mode register 0 (CSIM0) is tested. If “1”, normal transmission is judged to have been carried out. If “0”, a transmit error is judged to have occurred.

17.4.4 I²C bus mode operation

The I²C bus mode is provided for when communication operations are performed between a single master device and multiple slave devices. This mode configures a serial bus that includes only a single master device, and is based on the clocked serial I/O format with the addition of bus configuration functions, which allows the master device to communicate with a number of (slave) devices using only two lines: serial clock (SCL) line and serial data bus (SDA0 or SDA1) line. Consequently, when the user plans to configure a serial bus which includes multiple microcontrollers and peripheral devices, using this configuration results in reduction of the required number of port pins and on-board wires.

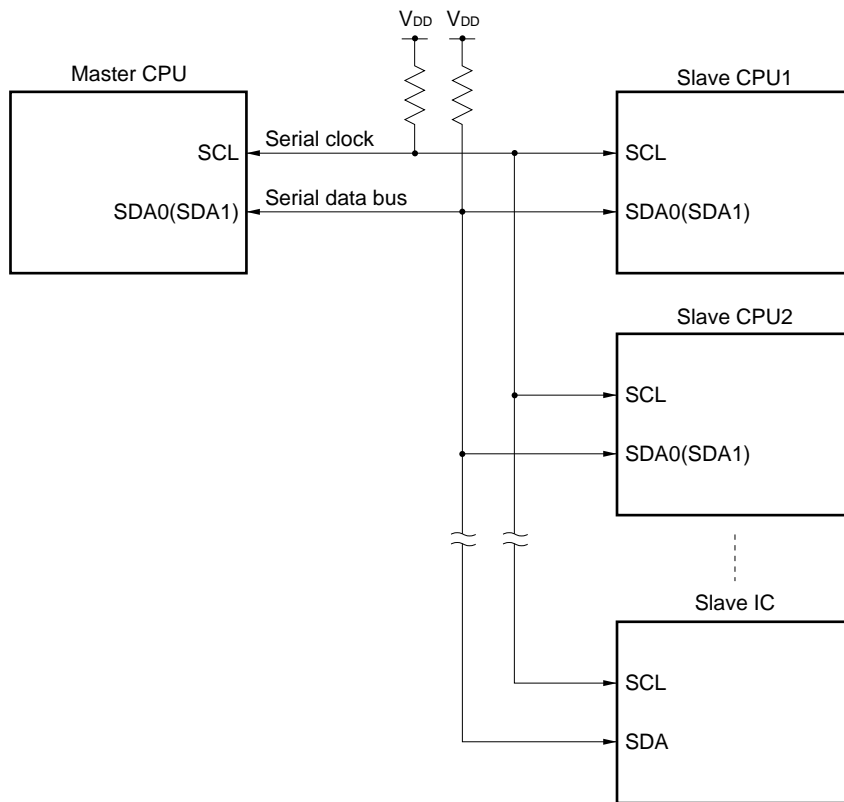
In the I²C bus specification, the master sends start condition, data, and stop condition signals to slave devices through the serial data bus, while slave devices automatically detect and distinguish the type of signals due to the signal detection function incorporated as hardware. This function simplifies the application program to control I²C bus.

An example of a serial bus configuration is shown in Figure 17-13. This system below is composed of CPUs and peripheral ICs having serial interface hardware that complies with the I²C bus specification.

Note that pull-up resistors are required to connect to both serial clock line and serial data bus line, because open-drain buffers are used for the serial clock pin (SCL) and the serial data bus pin (SDA0 or SDA1) on the I²C bus.

The signals used in the I²C bus mode are described in Table 17-4.

Figure 17-13. Example of Serial Bus Configuration Using I²C Bus



(1) I²C bus mode functions

In the I²C bus mode, the following functions are available.

(a) Automatic identification of serial data

Slave devices automatically detect and identifies start condition, data, and stop condition signals sent in series through the serial data bus.

(b) Chip selection by specifying device addresses

The master device can select a specific slave device connected to the I²C bus and communicate with it by sending in advance the address data corresponding to the destination device.

(c) Wake-up function

An interrupt request is generated during slave operation when the received address matches the value of slave address register (SVA). (the interrupt request also occurs when the stop condition is detected). Therefore, CPUs other than the selected slave device on the I²C bus can perform independent operations during the serial communication.

(d) Acknowledge signal ($\overline{\text{ACK}}$) control function

The master device and a slave device send and receive acknowledge signals to confirm that the serial communication has been executed normally.

(e) Wait signal ($\overline{\text{WAIT}}$) control function

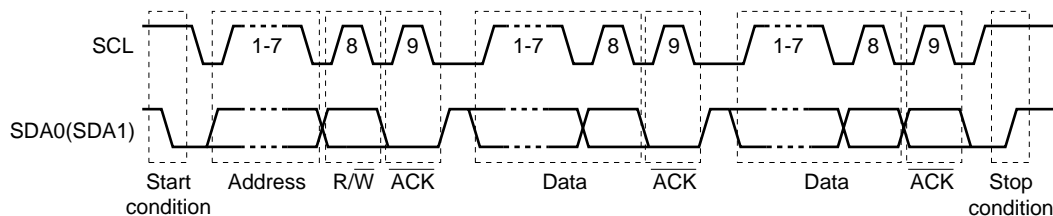
When a slave device is preparing for data transmission or reception and requires more waiting time, the slave device outputs a wait signal on the bus to inform the master device of the wait status.

(2) I²C bus definition

This section describes the format of serial data communications and functions of the signals used in the I²C bus mode.

First, the transfer timings of the start condition, data, and stop condition signals, which are output onto the signal data bus of the I²C bus, are shown in Figure 17-14.

Figure 17-14. I²C Bus Serial Data Transfer Timing

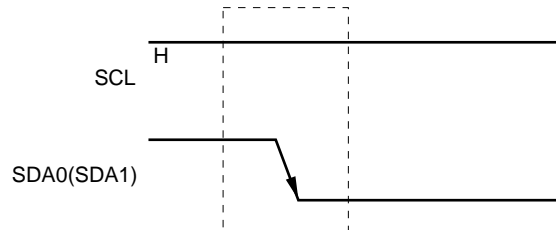


The start condition, slave address, and stop condition signals are output by the master. The acknowledge signal ($\overline{\text{ACK}}$) is output by either the master or the slave device (normally by the device which has received the 8-bit data that was sent). A serial clock (SCL) is continuously supplied from the master device.

(a) Start condition

When the SDA0 (SDA1) pin level is changed from high to low while the SCL pin is high, this transition is recognized as the start condition signal. This start condition signal, which is created using the SCL and SDA0 (or SDA1) pins, is output from the master device to slave devices to initiate a serial transfer. See section 17.4.5, "Cautions on Use of I²C Bus Mode," for details of the start condition output.

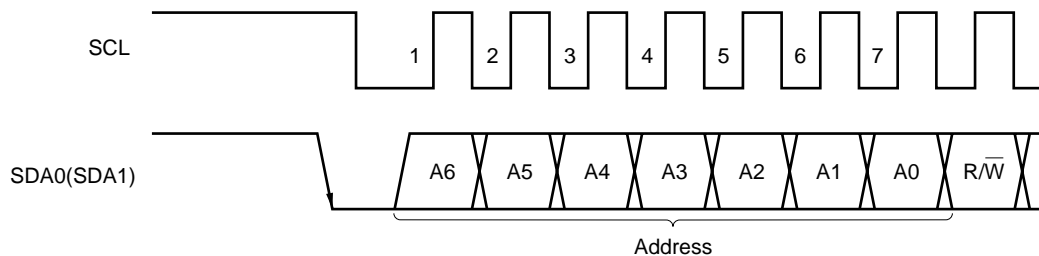
The start condition signal is detected by hardware incorporated in slave devices.

Figure 17-15. Start Condition**(b) Address**

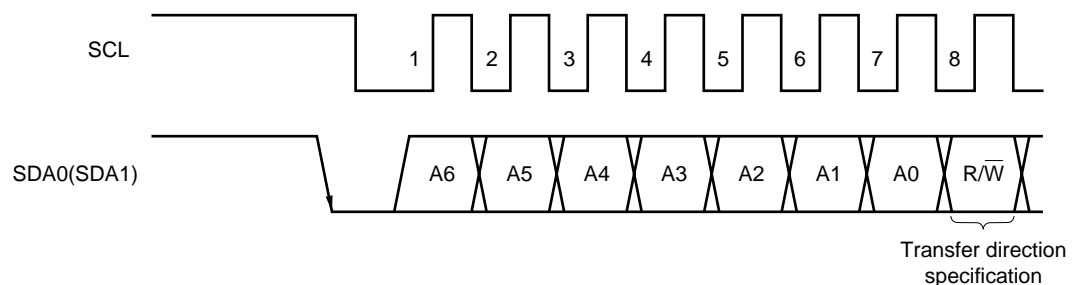
The 7 bits following the start condition signal are defined as an address.

The 7-bit address data is output by the master device to specify a specific slave from among those connected to the bus line. Each slave device on the bus line must therefore have a different address.

Therefore, after a slave device detects the start condition, it compares the 7-bit address data received and the data of the slave address register (SVA). After the comparison, only the slave device in which the data are a match becomes the communication partner, and subsequently performs communication with the master device until the master device sends a start condition or stop condition signal.

Figure 17-16. Address**(c) Transfer direction specification**

The 1 bit that follows the 7-bit address data will be sent from the master device, and it is defined as the transfer direction specification bit. If this bit is 0, it is the master device which will send data to the slave. If it is 1, it is the slave device which will send data to the master.

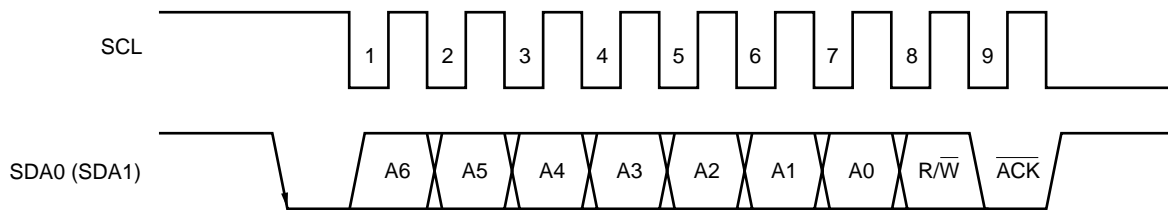
Figure 17-17. Transfer Direction Specification

(d) Acknowledge signal ($\overline{\text{ACK}}$)

The acknowledge signal indicates that the transferred serial data has definitely been received. This signal is used between the sending side and receiving side devices for confirmation of correct data transfer. In principle, the receiving side device returns an acknowledge signal to the sending device each time it receives 8-bit data. The only exception is when the receiving side is the master device and the 8-bit data is the last transfer data; the master device outputs no acknowledge signal in this case.

The sending side that has transferred 8-bit data waits for the acknowledge signal which will be sent from the receiving side. If the sending side device receives the acknowledge signal, which means a successful data transfer, it proceeds to the next processing. If this signal is not sent back from the slave device, this means that the data sent has not been received by the slave device, and therefore the master device outputs a stop condition signal to terminate subsequent transmissions.

Figure 17-18. Acknowledge Signal

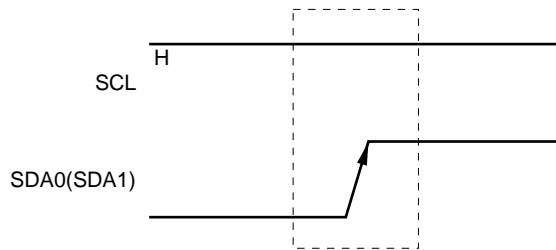


(e) Stop condition

If the SDA0 (SDA1) pin level changes from low to high while the SCL pin is high, this transition is defined as a stop condition signal.

The stop condition signal is output from the master to the slave device to terminate a serial transfer. The stop condition signal is detected by hardware incorporated in the slave device.

Figure 17-19. Stop Condition



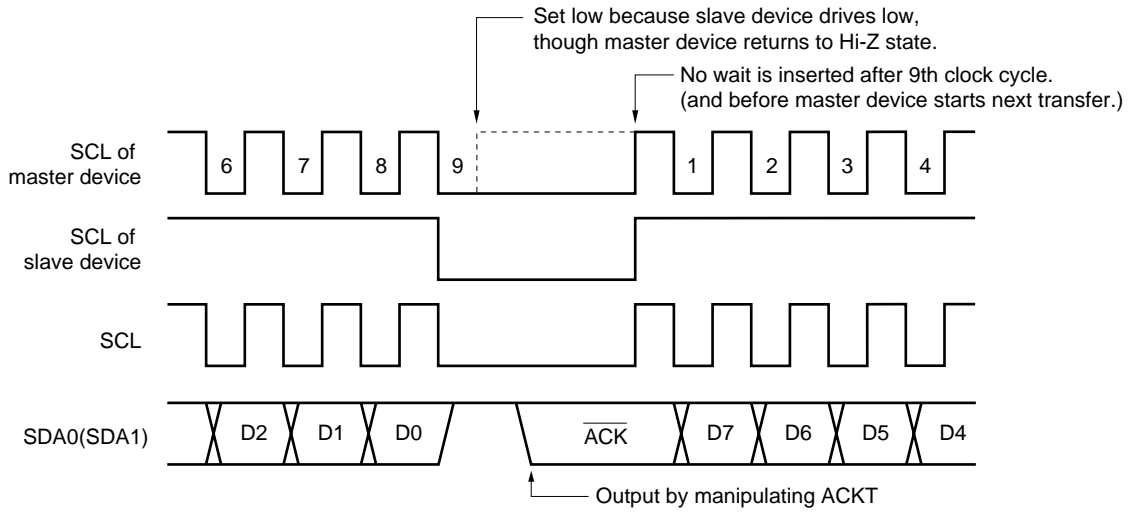
(f) Wait signal ($\overline{\text{WAIT}}$)

The wait signal is output by a slave device to inform the master device that the slave device is in wait state due to preparing for transmitting or receiving data.

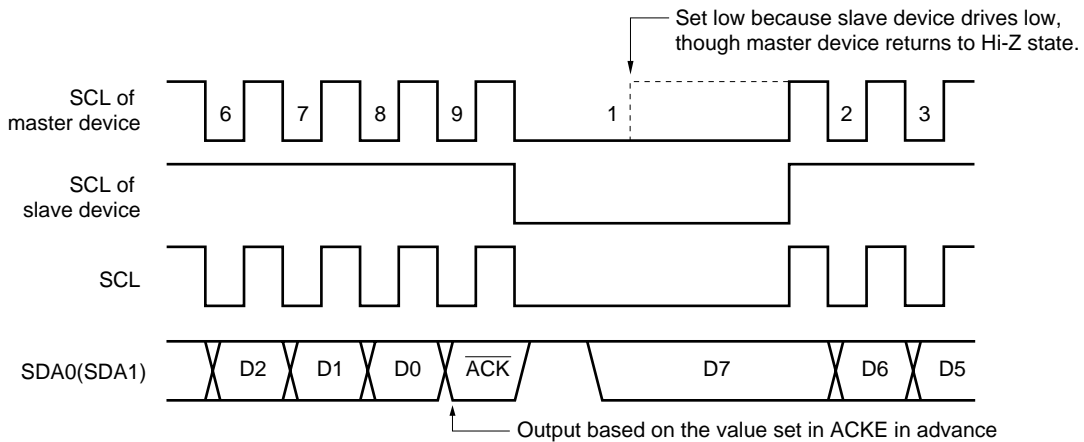
During the wait state, the slave device continues to output the wait signal by keeping the SCL pin low to delay subsequent transfers. When the wait state is released, the master device can start the next transfer. For the releasing operation of slave devices, see section 17.4.5, "Cautions on Use of I²C Bus Mode."

Figure 17-20. Wait Signal

(a) Wait of 8 Clock Cycles



(b) Wait of 9 Clock Cycles



(3) Register setting

The I²C mode is set with the serial operating mode register 0 (CSIM0), the serial bus interface control register (SBIC), and the interrupt timing specify register (SINT).

(a) Serial operating mode register 0 (CSIM0)

CSIM0 is set by a 1-bit or 8-bit memory manipulation instruction.
 RESET input sets 00H.

Symbol	<7>	<6>	<5>	4	3	2	1	0	Address	After Reset	R/W
CSIM0	CSIE0	COI	WUP	CSIM04	CSIM03	CSIM02	CSIM01	CSIM00	FF60H	00H	R/W ^{Note1}

R/W	CSIM01	CSIM00	Serial Interface Channel 0 Clock Selection								
	0	×	Input clock from off-chip to SCL pin								
	1	0	8-bit timer register 2 (TM2) output (See ^{Note 2})								
	1	1	Clock specified with bits 0 to 3 of timer clock select register 3 (TCL3)								

R/W	CSIM04	CSIM03	CSIM02	PM25	P25	PM26	P26	PM27	P27	Operation mode	Start bit	SI0/SB0/SDA0/ P25 pin function	S00/SB1/SDA1/ P26 pin function	SCK0/SCL/ P27 pin function
	0	×	3-wire serial I/O mode (see section 17.4.2 "Operation in 3-wire serial I/O mode")											
	1	1	0	×	×	0	0	0	1	2-wire serial I/O or I ² C bus mode	MSB	P25 (CMOS I/O)	SB1/SDA1 N-ch open-drain I/O	SCK0/SCL N-ch open-drain I/O
	1	1	1	0	0	×	×	0	1	2-wire serial I/O or I ² C bus mode	MSB	SB0/SDA0 N-ch open-drain I/O	P26 (CMOS I/O)	SCK0/SCL N-ch open-drain I/O

R/W	WUP	Wake-up Function Control ^{Note 4}										
	0	Interrupt request signal generation with each serial transfer in any mode										
	1	In I ² C bus mode, interrupt request signal is generated when the address data received after start condition detection (when CMDD = 1) matches data in slave address register (SVA).										

R	COI	Slave Address Comparison Result Flag (See ^{Note 5})										
	0	Slave address register (SVA) not equal to data in serial I/O shift register 0 (SIO0)										
	1	Slave address register (SVA) equal to data in serial I/O shift register 0 (SIO0)										

R/W	CSIE0	Serial Interface Channel 0 Operation Control										
	0	Stops operation.										
	1	Enables operation.										

- Notes**
1. Bit 6 (COI) is a read-only bit.
 2. In the I²C bus mode, the clock frequency is 1/16 of the clock frequency output by TO2.
 3. Can be used freely as a port.
 4. To use the wake-up function (WUP = 1), set the bit 5 (SIC) of the interrupt timing specify register (SINT) to 1. Do not execute an instruction that writes the serial I/O shift register 0 (SIO0) while WUP = 1.
 5. When CSIE0 = 0, COI is 0.

Remark × : Don't care
 PMxx : Port mode register
 Pxx : Port output latch

(b) Serial bus interface control register (SBIC)

SBIC is set by a 1-bit or 8-bit memory manipulation instruction.

$\overline{\text{RESET}}$ input sets SBIC to 00H.

Symbol	<7>	<6>	<5>	<4>	<3>	<2>	<1>	<0>	Address	After Reset	R/W
SBIC	BSYE	ACKD	ACKE	ACKT	CMDD	RELD	CMDT	RELT	FF61H	00H	R/W ^{Note}
R/W	RELT	Use for stop condition output. When RELT = 1, SO0 latch is set to 1. After SO0 latch setting, automatically cleared to 0. Also cleared to 0 when CSIE0 = 0.									
R/W	CMDT	Use for start condition output. When CMDT = 1, SO0 latch is cleared to 0. After clearing SO0 latch, automatically cleared to 0. Also cleared to 0 when CSIE0 = 0.									
R	RELD	Stop Condition Detection									
	0	Clear Conditions <ul style="list-style-type: none"> • When transfer start instruction is executed • If SIO0 and SVA values do not match in address reception • When CSIE0 = 0 • When $\overline{\text{RESET}}$ input is applied 									
	1	Setting Condition <ul style="list-style-type: none"> • When stop condition is detected 									
R	CMDD	Start Condition Detection									
	0	Clear Conditions <ul style="list-style-type: none"> • When transfer start instruction is executed • When stop condition is detected • When CSIE0 = 0 • When $\overline{\text{RESET}}$ input is applied 									
	1	Setting Condition <ul style="list-style-type: none"> • When start condition is detected 									
R/W	ACKT	SDA0 (SDA1) is set to low after the Set instruction execution (ACKT = 1) before the next SCL falling edge. Used for generating an $\overline{\text{ACK}}$ signal by software if the 8-clock wait mode is selected. Cleared to 0 if CSIE = 0 when a transfer by the serial interface is started.									

(continued)

Note Bits 2, 3, and 6 (RELD, CMDD, ACKD) are read-only bits.

Remarks 1. Bits 0, 1, and 4 (RELT, CMDT, ACKT) are 0 when read after the data is set.

2. CSIE0: Bit 7 of serial operating mode register 0 (CSIM0)

R/W	ACKE	Acknowledge Signal Automatic Output Control ^{Note 1}
	0	Disabled (with ACKT enabled). Used when receiving data in the 8-clock wait mode or when transmitting data. ^{Note 2}
	1	Enabled. After completion of transfer, acknowledge signal is output in synchronization with the 9th falling edge of SCL clock (automatically output when ACKE = 1). However, not automatically cleared to 0 after acknowledge signal output. Used for reception when the 9-clock wait mode is selected.
R	ACKD	Acknowledge Detection
	0	Clear Conditions <ul style="list-style-type: none"> • When transfer start instruction is executed • When CSIE0 = 0 • When $\overline{\text{RESET}}$ input is applied
	1	Set Conditions <ul style="list-style-type: none"> • When acknowledge signal is detected at the rising edge of SCL clock after completion of transfer
R/W	BSYE ^{Note 3}	Control of N-ch Open-Drain Output for Transmission in I ² C Bus Mode ^{Note 4}
	0	Output enabled (transmission)
	1	Output disabled (reception)

- Notes**
1. This setting must be performed prior to transfer start.
 2. In the 8-clock wait mode, use ACKT for output of the acknowledge signal after normal data reception.
 3. The busy mode can be released by the start of a serial interface transfer or reception of an address signal. However, the BSYE flag is not cleared.
 4. When using the wake-up function, be sure to set BSYE to 1.

Remark CSIE0: Bit 7 of serial operating mode register 0 (CSIM0)

(c) Interrupt timing specification register (SINT)

SINT is set by the 1-bit or 8-bit memory manipulation instruction.

$\overline{\text{RESET}}$ input sets SINT to 00H.

Symbol	7	<6>	<5>	<4>	<3>	<2>	1	0	Address	After Reset	R/W
SINT	0	CLD	SIC	SVAM	CLC	WREL	WAT1	WAT0	FF63H	00H	R/W ^{Note1}
R/W	WAT1	WAT0	Interrupt control by wait (See Note 2)								
	0	0	Interrupt service request is generated on rise of 8th $\overline{\text{SCK0}}$ clock cycle (clock output is high impedance).								
	0	1	Setting prohibited								
	1	0	Used in I ² C bus mode (8-clock wait) Generates an interrupt service request on rise of 8th SCL clock cycle. (In case of master device, SCL pin is driven low after output of 8 clock cycles, to enter the wait state. In case of slave device, SCL pin is driven low after input of 8 clock cycles, to require the wait state.)								
	1	1	Used in I ² C bus mode (9-clock wait) Generates an interrupt service request on rise of 9th SCL clock cycle. (In case of master device, SCL pin is driven low after output of 9 clock cycles, to enter the wait state. In case of slave device, SCL pin is driven low after input of 9 clock cycles, to require the wait state.)								
R/W	WREL	Wait release control									
	0	Indicates that the wait state has been released.									
	1	Releases the wait state. Automatically cleared to 0 after releasing the wait state. This bit is used to release the wait state set by means of WAT0 and WAT1.									
R/W	CLC	Clock level control									
	0	Used in I ² C bus mode. In cases other than serial transfer, SCL pin output is driven low.									
	1	Used in I ² C bus mode. In cases other than serial transfer, SCL pin output is set to high impedance. (Clock line is held high.) Used by master device to generate the start condition and stop condition signals.									
R/W	SVAM	SVA bits used as slave address									
	0	Bits 0 to 7									
	1	Bits 1 to 7									
R/W	SIC	INTCSAIO interrupt source selection ^{Note 3}									
	0	CSIF0 is set to 1 after end of serial interface channel 0 transfer.									
	1	CSIF0 is set to 1 after end of serial interface channel 0 transfer or when stop condition is detected.									
R	CLD	SCL pin level (See Note 4)									
	0	Low level									
	1	High level									

Notes 1. Bit 6 (CLD) is read-only.

2. When the I²C bus mode is used, be sure to set 1 and 0, or 1 and 1 in WAT0 and WAT1, respectively.

3. When using the wake-up function in I²C mode, be sure to set SIC to 1.

4. When CSIE0 = 0, CLD is 0.

Remark SVA : Slave address register

CSIF0 : Interrupt request flag corresponding to INTCSIO

CSIE0 : Bit 7 of serial operating mode register 0 (CSIM0)

(4) Various signals

A list of signals in the I²C bus mode is given in Table 17-4.

Table 17-4. Signals in I²C Bus Mode

Signal name	Description
Start condition	Definition : SDA0 (SDA1) falling edge when SCL is high ^{Note 1}
	Function : Indicates that serial communication starts and subsequent data are address data.
	Signaled by : Master
	Signaled when : CMDT is set.
	Affected flag(s) : CMDD (is set.)
Stop condition	Definition : SDA0 (SDA1) rising edge when SCL is high ^{Note 1}
	Function : Indicates end of serial transmission.
	Signaled by : Master
	Signaled when : RELT is set.
	Affected flag(s) : RELD (is set) and CMDD (is cleared)
Acknowledge signal (ACK)	Definition : Low level of SDA0(SDA1) pin during one SCL clock cycle after serial reception
	Function : Indicates completion of reception of 1 byte.
	Signaled by : Master or slave
	Signaled when : ACKT is set with ACKE = 1.
	Affected flag(s) : ACKD (is set.)
Wait (WAIT)	Definition : Low-level signal output to SCL
	Function : Indicates state in which serial reception is not possible.
	Signaled by : Slave
	Signaled when : WAT1, WAT0 = 1x.
	Affected flag(s) : None
Serial Clock (SCL)	Definition : Synchronization clock for output of various signals
	Function : Serial communication synchronization signal.
	Signaled by : Master
	Signaled when : See Note 2 below.
	Affected flag(s) : CSIF0. Also see Note 3 below.
Address (A6 to A0)	Definition : 7-bit data synchronized with SCL immediately after start condition signal
	Function : Indicates address value for specification of slave on serial bus.
	Signaled by : Master
	Signaled when : See Note 2 below.
	Affected flag(s) : CSIF0. Also see Note 3 below.
Transfer direction (R/ \bar{W})	Definition : 1-bit data output in synchronization with SCL after address output
	Function : Indicates whether data transmission or reception is to be performed.
	Signaled by : Master
	Signaled when : See Note 2 below.
	Affected flag(s) : CSIF0. Also see Note 3 below.
Data (D7 to D0)	Definition : 8-bit data synchronized with SCL, not immediately after start condition
	Function : Contains data actually to be sent.
	Signaled by : Master or slave
	Signaled when : See Note 2 below.
	Affected flag(s) : CSIF0. Also see Note 3 below.

- Notes**
1. The level of the serial clock can be controlled by CLC of interrupt timing specify register (SINT).
 2. Execution of instruction to write data to SIO0 when CSIE0 = 1 (serial transfer start directive). In the wait state, the serial transfer operation will be started after the wait state is released.
 3. If the 8-clock wait is selected when WUP = 0, CSIF0 is set at the rising edge of the 8th clock cycle of SCL. If the 9-clock wait is selected when WUP = 0, CSIF0 is set at the rising edge of the 9th clock cycle of SCL. CSIF0 is set if an address is received and that address coincides with the value of the slave address register (SVA) when WUP = 1, or if the stop condition is detected.

(5) Pin configurations

The configurations of the serial clock pin SCL and the serial data bus pins SDA0 (SDA1) are shown below.

(a) SCL

Pin for serial clock input/output dual-function pin.

<1> Master N-ch open-drain output

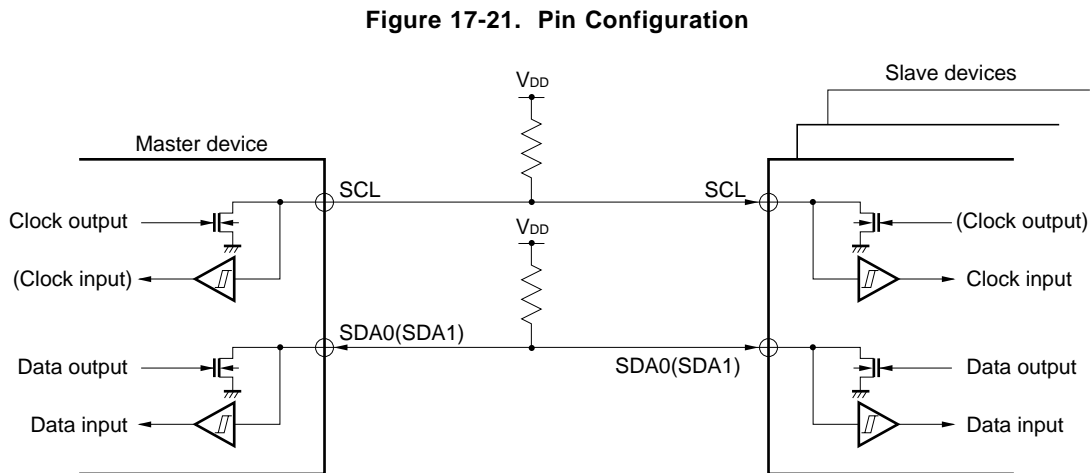
<2> Slave Schmitt input

(b) SDA0 (SDA1)

Serial data input/output dual-function pin.

Uses N-ch open-drain output and Schmitt-input buffers for both master and slave devices.

Note that pull-up resistors are required to connect to both serial clock line and serial data bus line, because open-drain buffers are used for the serial clock pin (SCL) and the serial data bus pin (SDA0 or SDA1) on the I²C bus.



Caution To receive data, the N-ch open-drain output must be set to high-impedance state. Therefore, set the bit 7 (BSYE) of the serial bus interface control register (SBIC) to 1 in advance, and write FFH to the serial I/O shift register 0 (SIO0).

When the wake-up function is used (by setting the bit 5 (WUP) of the serial operating mode register 0 (CSIM0)), however, do not write FFH to SIO0 before reception. Even if FFH is not written to SIO0, the N-ch open-drain output is always in high-impedance state.

(6) Address match detection method

In the I²C mode, the master can select a specific slave device by sending slave address data.

CSIF0 is set if the slave address transmitted by the master coincides with the value set to the slave address register (SVA) when a slave device address has a slave register (SVA), and the wake-up function specify bit (WUP) = 1 (CSIF0 is also set when the stop condition is detected).

When using the wake-up function, set SIC to 1.

Caution Slave selection/non-selection is detected by matching of the data (address) received after start condition.

For this match detection, match detection interrupt request (INTCSI0) of the address to be generated with WUP = 1 is normally used. Thus, execute selection/non-selection detection by slave address when WUP = 1.

(7) Error detection

In the I²C bus mode, transmission error detection can be performed by the following methods because the serial bus SDA0 (SDA1) status during transmission is also taken into the serial I/O shift register 0 (SIO0) register of the transmitting device.

(a) Comparison of SIO0 data before and after transmission

In this case, a transmission error is judged to have occurred if the two data values are different.

(b) Using the slave address register (SVA)

Transmit data is set in SIO0 and SVA before transmission is performed. After transmission, the COI bit (match signal from the address comparator) of serial operating mode register 0 (CSIM0) is tested: "1" indicates normal transmission, and "0" indicates a transmission error.

(8) Communication operation

In the I²C bus mode, the master selects the slave device to be communicated with from among multiple devices by outputting address data onto the serial bus.

After the slave address data, the master sends the R/W bit which indicates the data transfer direction, and starts serial communication with the selected slave device.

Data communication timing charts are shown in **Figures 17-22** and **17-23**.

In the transmitting device, the serial I/O shift register 0 (SIO0) shifts transmission data to the SO latch in synchronization with the falling edge of the serial clock (SCL), the SO0 latch outputs the data on an MSB-first basis from the SDA0 or SDA1 pin to the receiving device.

In the receiving device, the data input from the SDA0 or SDA1 pin is taken into the SIO0 in synchronization with the rising edge of SCL.

(9) Start of transfer

A serial transfer is started by setting transfer data in serial I/O shift register 0 (SIO0) if the following two conditions have been satisfied:

- The serial interface channel 0 operation control bit (CSIE0) = 1.
- After an 8-bit serial transfer, the internal serial clock is stopped or SCL is low.

Cautions 1. Be sure to set CSIE0 to 1 before writing data in SIO0. Setting CSIE0 to 1 after writing data in SIO0 does not initiate transfer operation.

2. **Because the N-ch open-drain output must be high-impedance state during data reception, set bit 7 (BSYE) of serial bus interface control register (SBIC) to 1 before writing FFH to SIO0.**

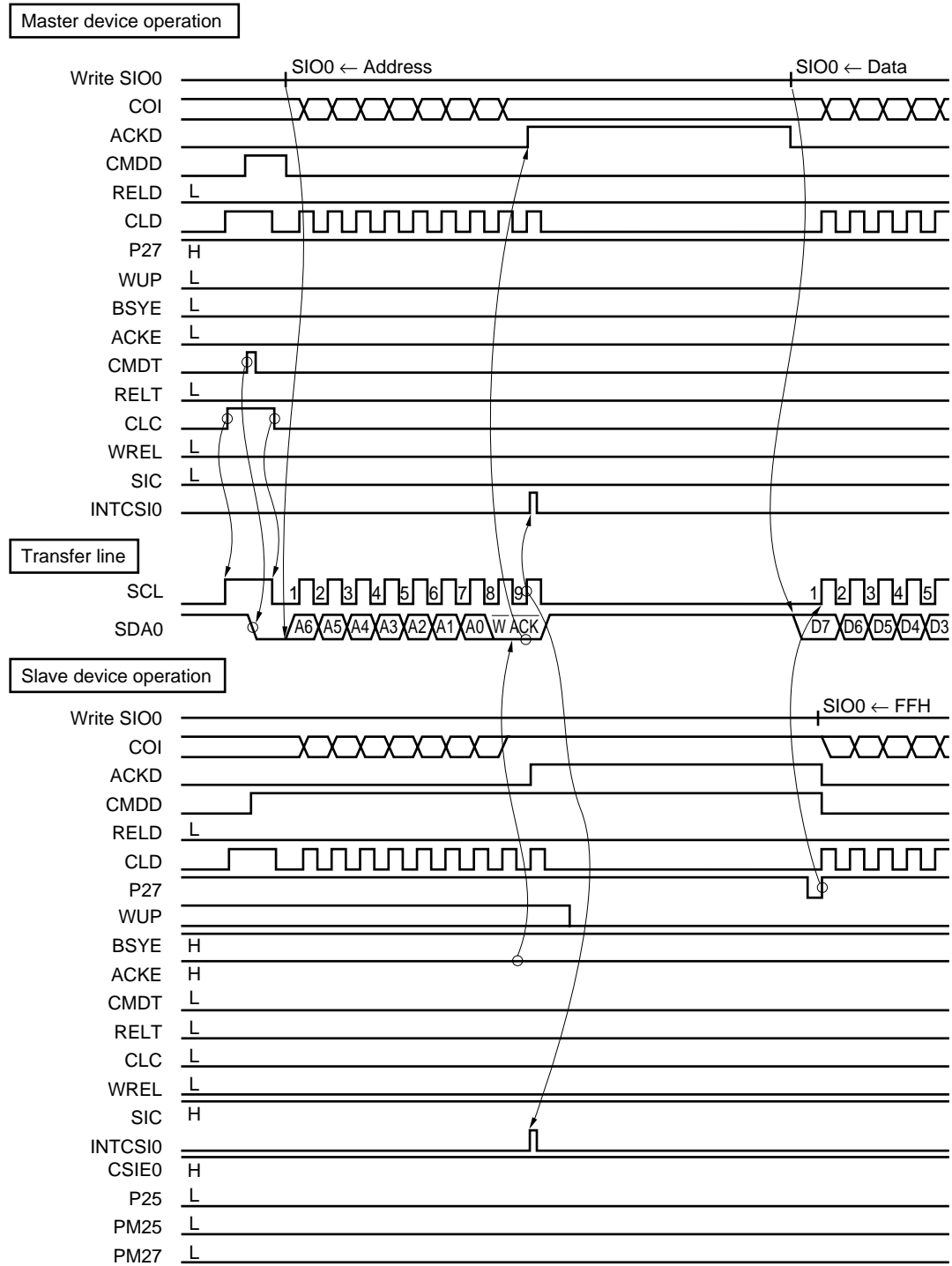
Do not write FFH to SIO0 before reception when the wake-up function is used (by setting the bit 5 (WUP) of the serial operating mode register 0 (CSIM0)). Even if FFH is not written to SIO0, the N-ch open-drain output is always in high-impedance state.

3. **If data is written to SIO0 while the slave is in the wait state, that data is held. The transfer is started when SCL is output after the wait state is cleared.**

When an 8-bit data transfer ends, serial transfer is stopped automatically and the interrupt request flag (CSIIF0) is set.

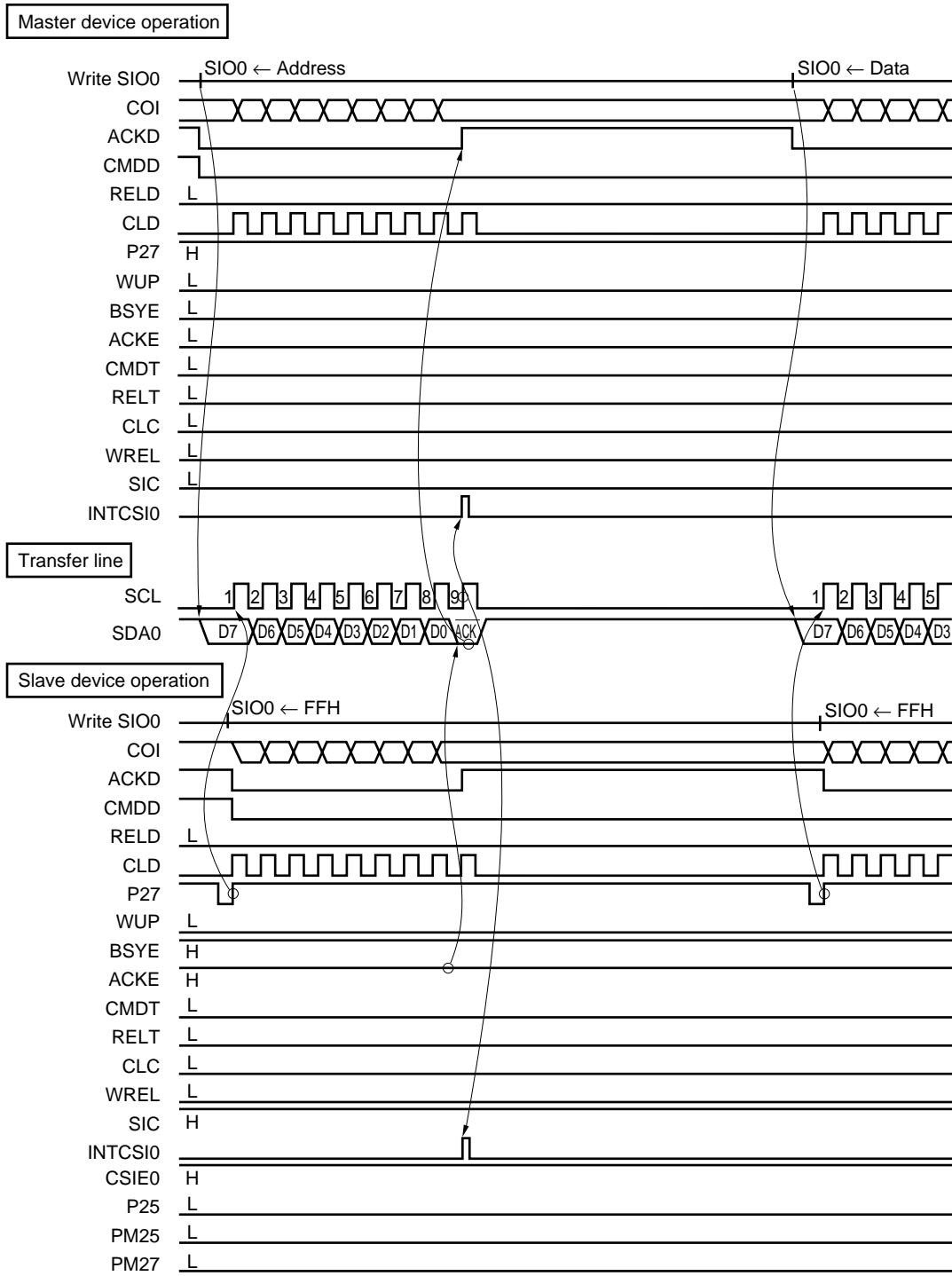
Figure 17-22. Data Transmission from Master to Slave
(Both Master and Slave Selected 9-Clock Wait) (1 of 3)

(a) Start Condition to Address



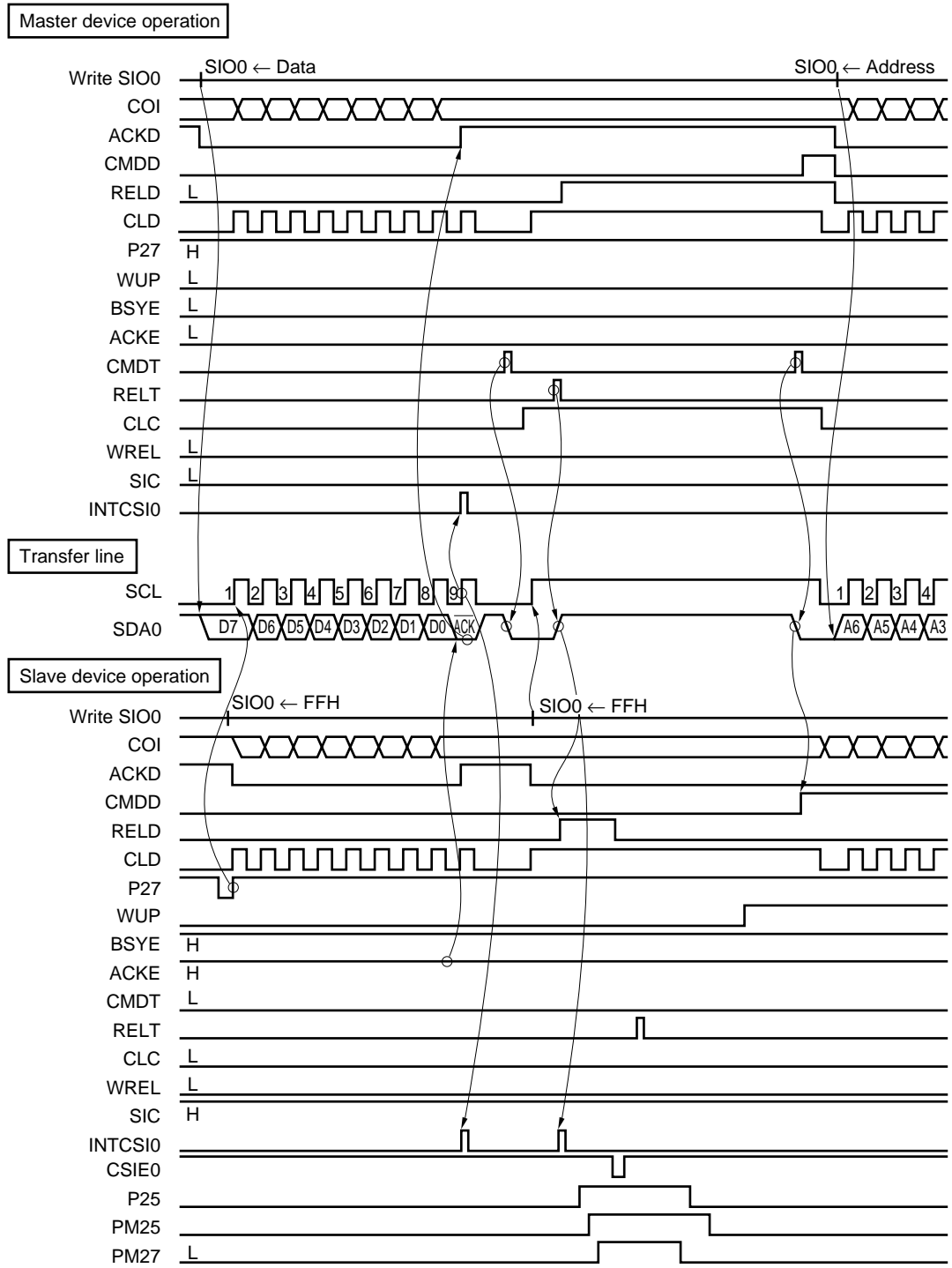
**Figure 17-22. Data Transmission from Master to Slave
(Both Master and Slave Selected 9-Clock Wait) (2 of 3)**

(b) Data



**Figure 17-22. Data Transmission from Master to Slave
(Both Master and Slave Selected 9-Clock Wait) (3 of 3)**

(c) Stop Condition



**Figure 17-23. Data Transmission from Slave to Master
(Both Master and Slave Selected 9-Clock Wait) (1 of 3)**

(a) Start Condition to Address

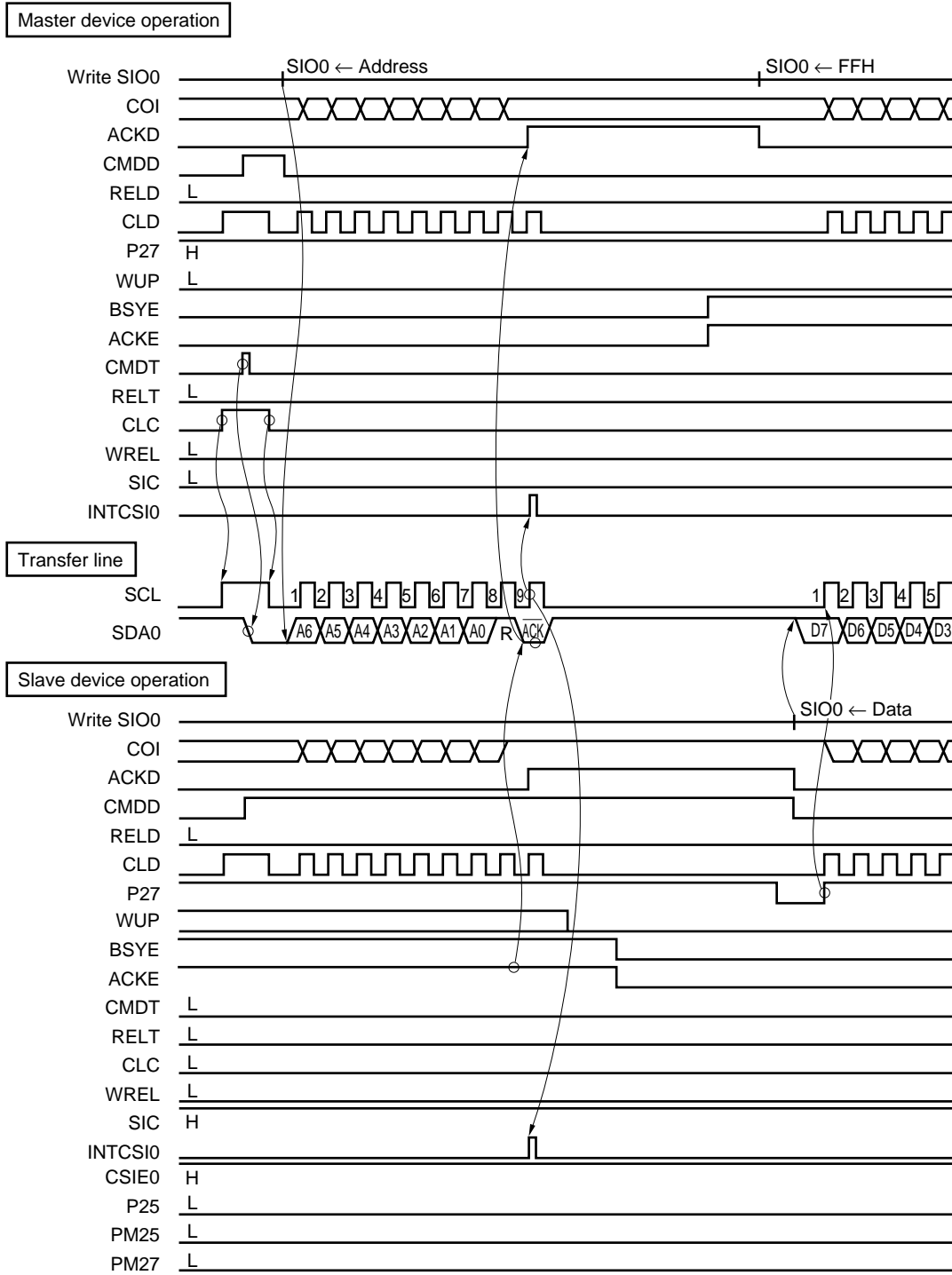
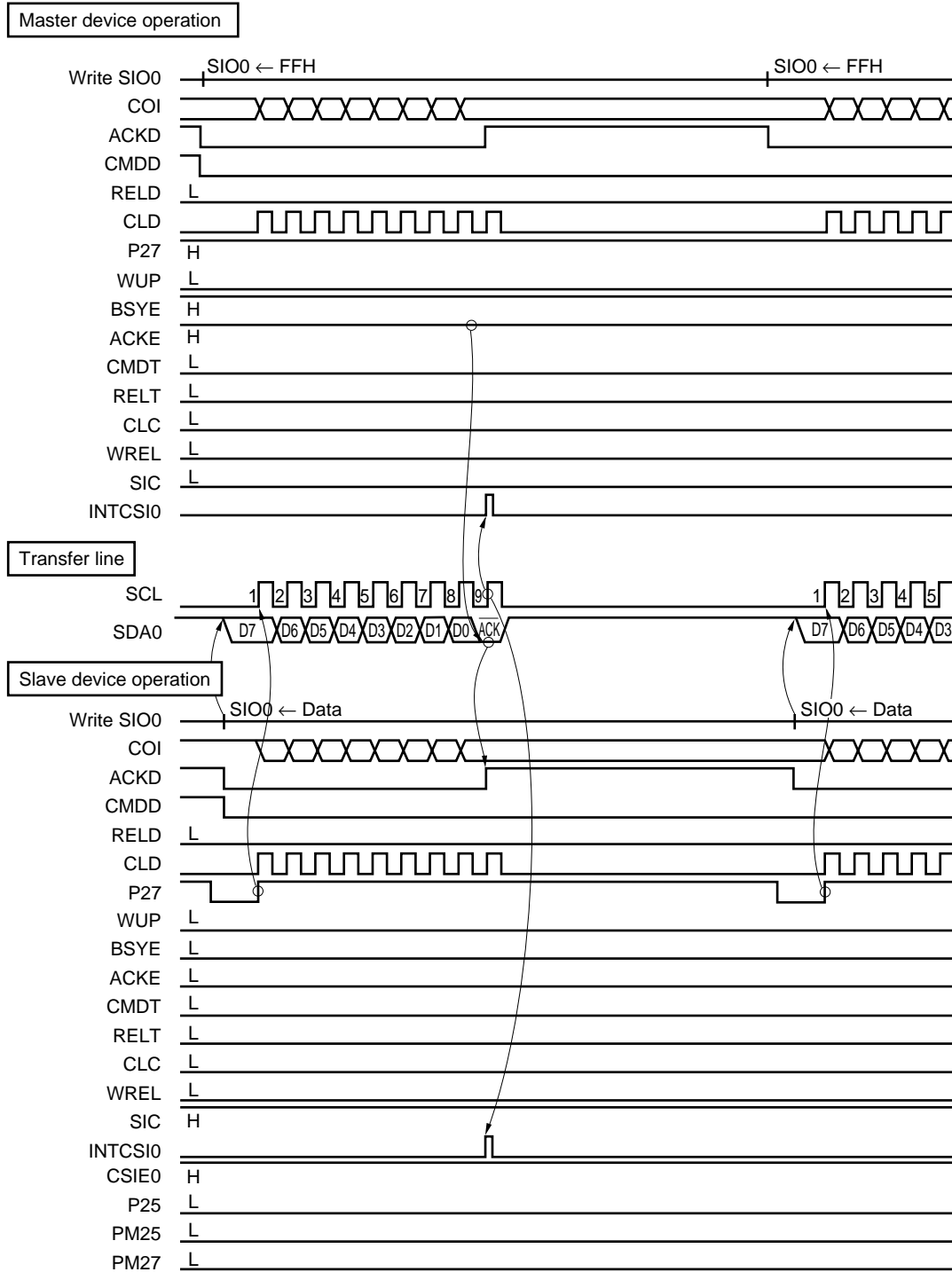


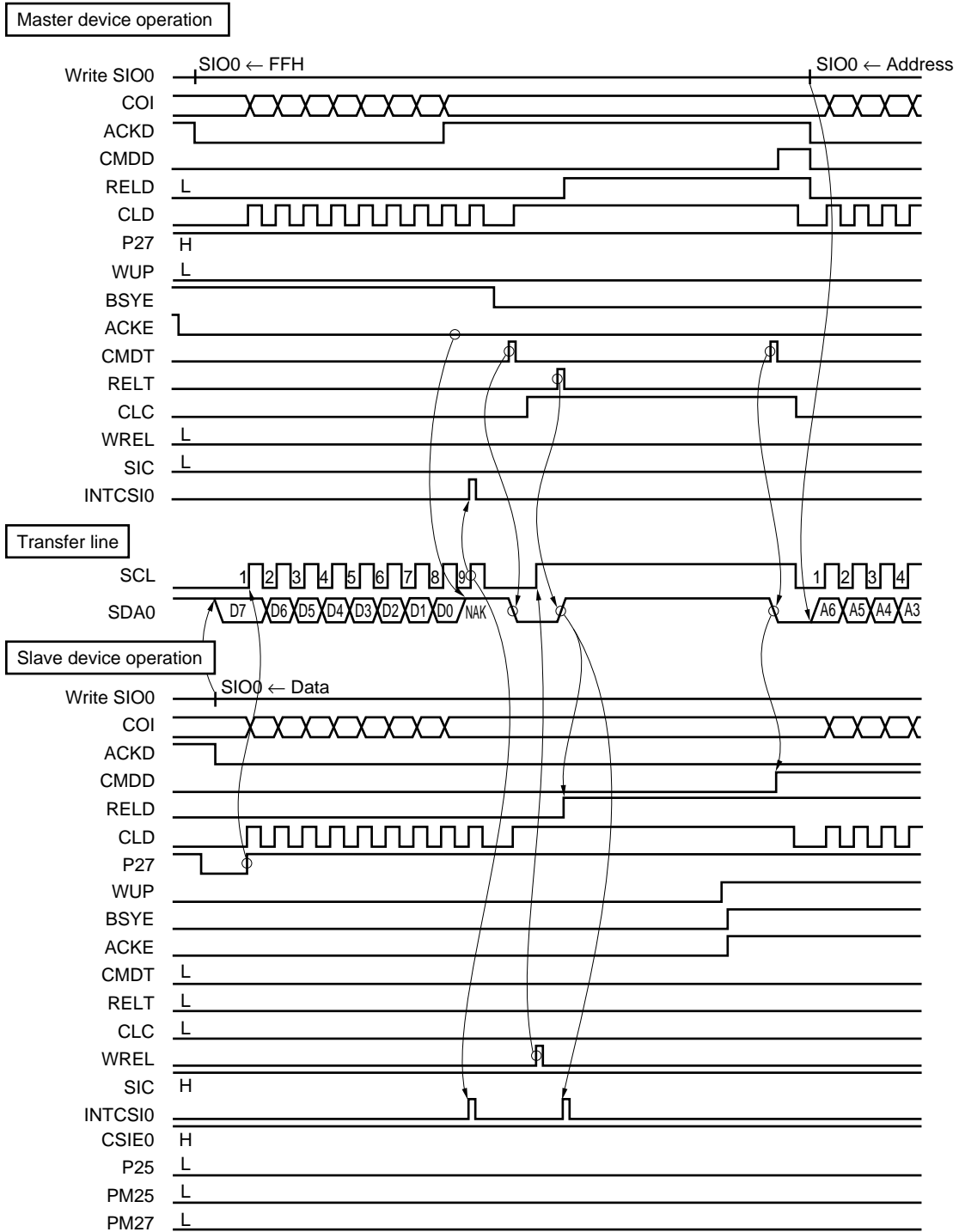
Figure 17-23. Data Transmission from Slave to Master
(Both Master and Slave Selected 9-Clock Wait) (2 of 3)

(b) Data



**Figure 17-23. Data Transmission from Slave to Master
(Both Master and Slave Selected 9-Clock Wait) (3 of 3)**

(c) Stop Condition



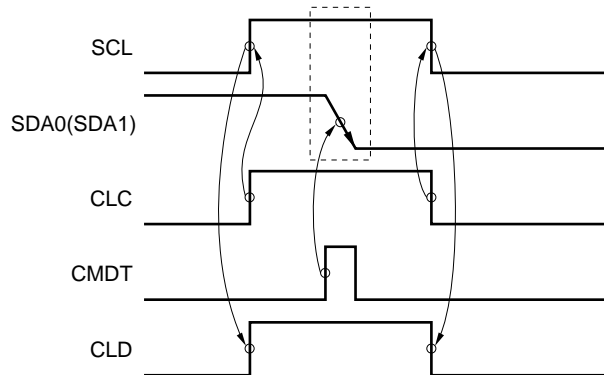
17.4.5 Cautions on use of I²C bus mode

(1) Start condition output (master)

The SCL pin normally outputs a low-level signal when no serial clock is output. It is necessary to change the SCL pin to high in order to output a start condition signal. Set 1 in CLC of interrupt timing specify register (SINT) to drive the SCL pin high.

After setting CLC, clear CLC to 0 and return the SCL pin to low. If CLC remains 1, no serial clock is output. If it is the master device which outputs the start condition and stop condition signals, confirm that CLD is set to 1 after setting CLC to 1; a slave device may have set SCL to low (wait state).

Figure 17-24. Start Condition Output



(2) Slave wait release (slave transmission)

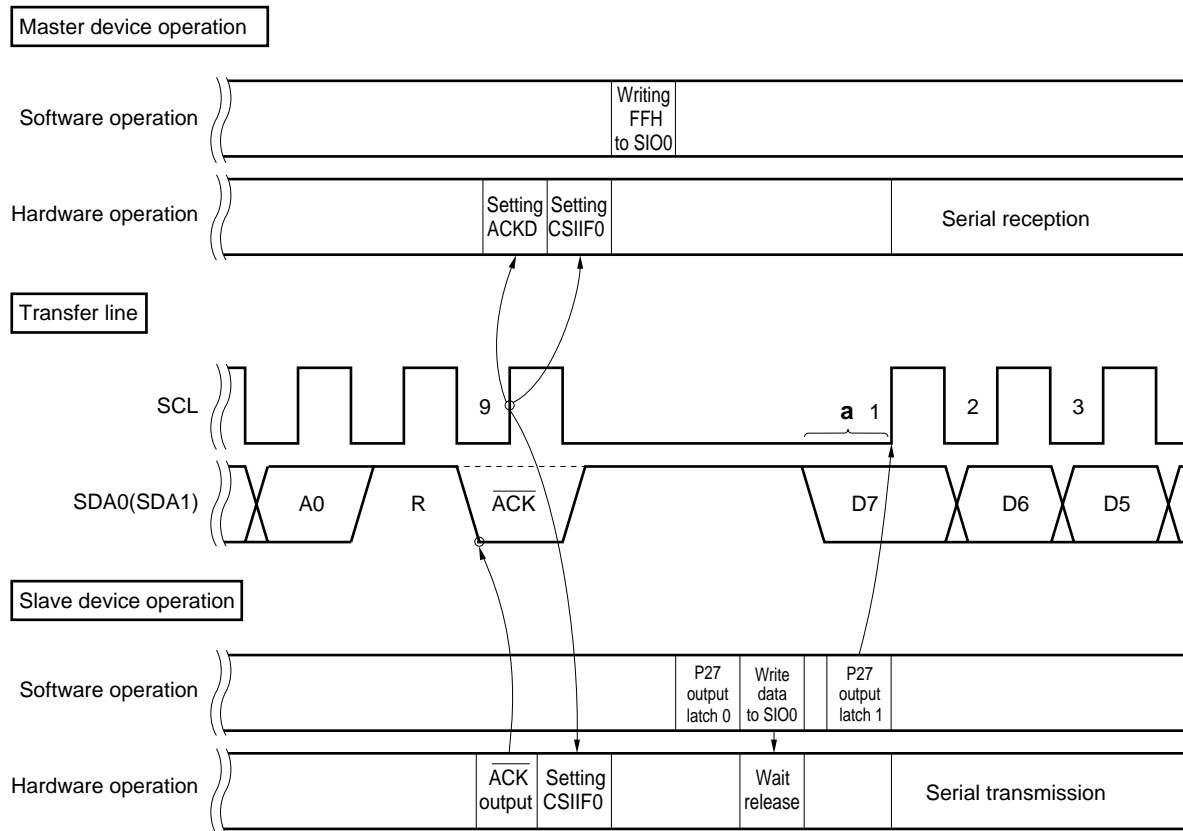
Slave wait status is released by WREL flag (bit 2 of interrupt timing specify register (SINT)) setting or execution of an serial I/O shift register 0 (SIO0) write instruction.

If the slave sends data, the wait is immediately released by execution of an SIO0 write instruction and the clock rises without the start transmission bit being output in the data line. Therefore, as shown in Figure 17-25, data should be transmitted by manipulating the P27 output latch through the program. At this time, control the low-level width ("a" in **Figure 17-25**) of the first serial clock at the timing used for setting the P27 output latch to 1 after execution of an SIO0 write instruction.

In addition, if the acknowledge signal from the master is not output (if data transmission from the slave is completed), set 1 in the WREL flag of SINT and release the wait.

For these timings, see Figure 17-23.

Figure 17-25. Slave Wait Release (Transmission)



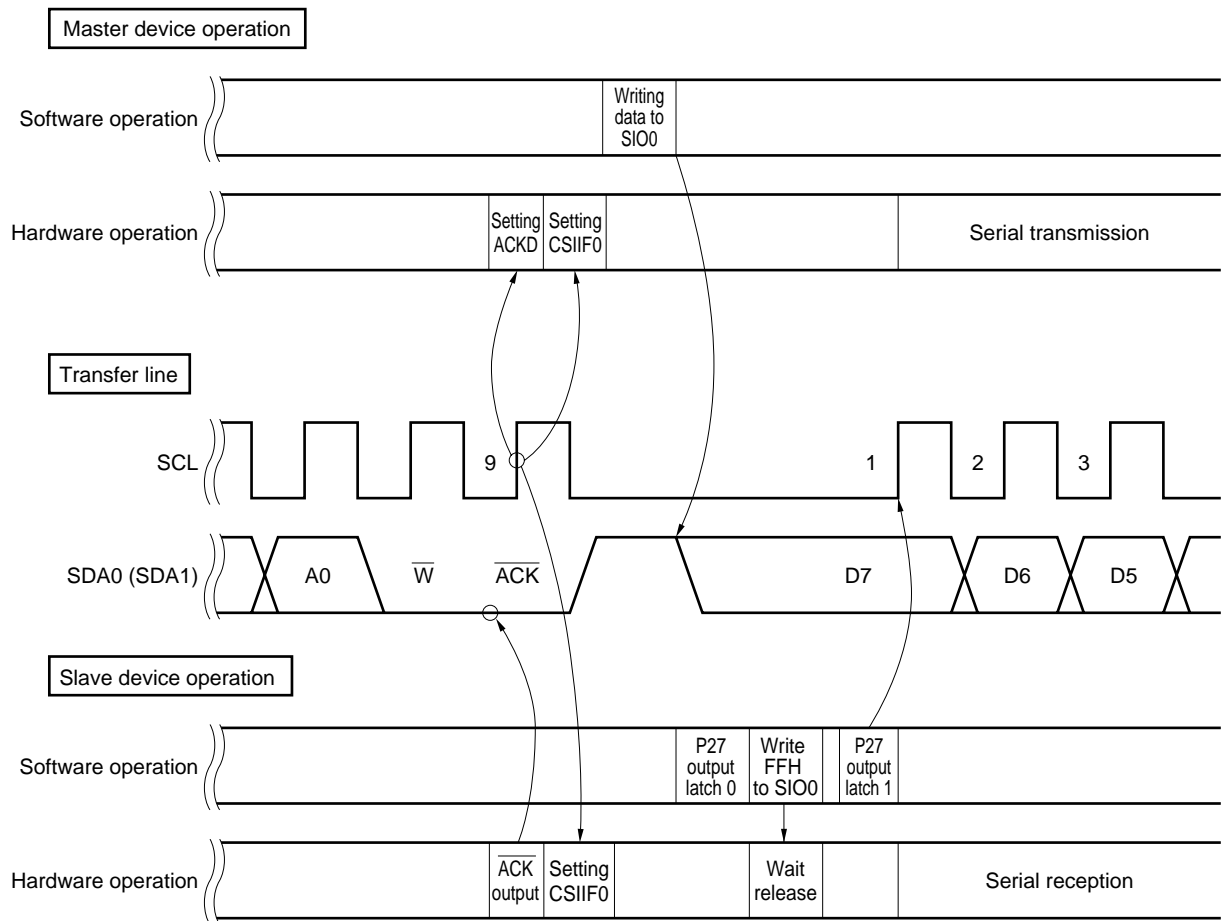
(3) Slave wait release (slave reception)

The slave is released from the wait status when the WREL flag (bit 2 of the interrupt timing specify register (SINT)) is set or when an instruction that writes data to the serial I/O shift register 0 (SIO0) is executed. When the slave receives data, the first bit of the data sent from the master may not be received if the SCL line immediately goes into a high-impedance state after an instruction that writes data to SIO0 has been executed.

This is because SIO0 does not start operating if the SCL line is in the high-impedance state while the instruction that writes data to SIO0 is executed (until the next instruction is executed).

Therefore, receive the data by manipulating the output latch of P27 by program, as shown in Figure 17-26. For this timing, refer to Figure 17-22.

Figure 17-26. Slave Wait Release (Reception)



(4) Reception completion of salve

In the reception completion processing of the slave, check the bit 3 (CMDD) of the serial bus interface control register (SBIC) and bit 6 (COI) of the serial operation mode register 0 (CSIM0) (when CMDD = 1). This is to avoid the situation where the slave cannot judge which of the start condition and data comes first and therefore, the wake-up condition cannot be used when the slave receives the undefined number of data from the master.

17.4.6 Restrictions in I²C bus mode

The following restrictions are applied to the μ PD78054Y subseries.

- Restrictions when used as slave device in I²C bus mode

Subject: μ PD78052Y, 78053Y, 78054Y, 78055Y, 78056Y, 78058Y, 78P058Y, IE-78064-R-EM, IE-780308-R-EM

Description: If the wake-up function is executed (by setting the bit 5 of the serial operating mode register 0 (CSIM0) to 1) in the serial transfer status^{Note}, the μ PD78054Y subseries checks the address of the data between the other slave and master. If that data happens to coincide with the slave address of the μ PD78054Y subseries, the μ PD78054Y subseries takes part in communication, destroying the communication data.

Note The serial transfer status is the status since data has been written to the serial I/O shift register 0 (SIO0) until the interrupt request flag (CSIF0) is set to 1 by completion of the serial transfer.

Preventive measure: The above phenomenon can be avoided by modifying the program. Before executing the wake-up function, execute the following program that clears the serial transfer status. When executing the wake-up function, do not execute an instruction that writes data to SIO0. Even if such an instruction is not executed, data can be received while the wake-up function is executed.

This program releases the serial transfer status. To release the serial transfer status, the serial interface channel 0 must be once disabled (by clearing the CSIE0 flag (bit 7 of the serial operating mode register (CSIM0) to 0). If the serial interface channel 0 is disabled in the I²C bus mode, however, the SCL pin outputs a high level, and SDA0 (SDA1) pin outputs a low level, affecting communication of the I²C bus. Therefore, this program makes the SCL and SDA0 (SDA1) pins go into a high-impedance state to prevent the I²C bus from being affected.

In this example, the SDA0 (/P25) pin is used as a serial data input/output pin. When the SDA1 (/P26) is used, take P2.5 and PM2.5 in the program example below as P2.6 and PM2.6.

For the timing of each signal when this program is executed, refer to Figure 17-22.

- Example of program releasing serial transfer status

```

SET1 P2.5;    <1>
SET1 PM2.5;  <2>
SET1 PM2.7;  <3>
CLR1 CSIE0;  <4>
SET1 CSIE0;  <5>
SET1 RELT;   <6>
CLR1 PM2.7;  <7>
CLR1 P2.5;   <8>
CLR1 PM2.5;  <9>

```

- <1> This instruction prevents the SDA0 pin from outputting a low level when the I²C bus mode is restored by instruction <5>. The output of the SDA0 pin goes into a high-impedance state.
- <2> This instruction sets the P25 (/SDA0) pin in the input mode to protect the SDA0 line from adverse influence when the port mode is set by instruction <4>. The P25 pin is set in the input mode when instruction <2> is executed.
- <3> This instruction sets the P27 (/SCL) pin in the input mode to protect the SCL line from adverse influence when the port mode is set by instruction <4>. The P27 pin is set in the input mode when instruction <3> is executed.
- <4> This instruction changes the mode from I²C bus mode to port mode.
- <5> This instruction restores the I²C bus mode from the port mode.
- <6> This instruction prevents the SDA0 pin from outputting a low level when instruction <8> is executed.
- <7> This instruction sets the P27 pin in the output mode because the P27 pin must be in the output mode in the I²C bus mode.
- <8> This instruction clears the output latch of the P25 pin to 0 because the output latch of the P25 pin must be set to 0 in the I²C bus mode.
- <9> This instruction sets the P25 pin in the output mode because the P25 pin must be in the output mode in the I²C bus mode.

Remark RELT: Bit 0 of serial bus interface control register (SBIC)

17.4.7 $\overline{\text{SCK0/SCL/P27}}$ pin output manipulation

The $\overline{\text{SCK0/SCL/P27}}$ pin can execute static output via software, in addition to outputting the normal serial clock.

The value of serial clocks can also be arbitrarily set by software (the SI0/SB0/SDA0 and SO0/SB1/SDA1 pins are controlled with the RELT and CMDT bits of serial bus interface control register (SBIC)).

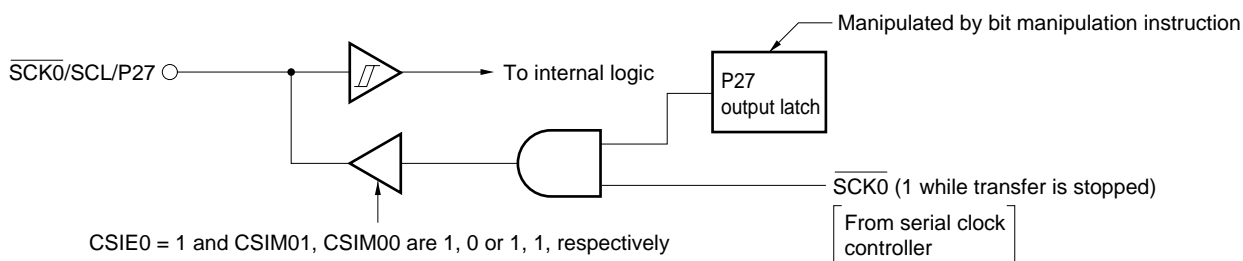
The $\overline{\text{SCK0/SCL/P27}}$ pin output should be manipulated as described below.

(1) In 3-wire serial I/O mode and 2-wire serial I/O mode

The output level of the $\overline{\text{SCK0/SCL/P27}}$ pin is manipulated by the P27 output latch.

- <1> Set the serial operating mode register 0 (CSIM0) ($\overline{\text{SCK0}}$ pin is set in the output mode and serial operation is enabled). $\overline{\text{SCK0}} = 1$ while serial transfer is stopped.
- <2> Manipulate the content of the P27 output latch by executing the bit manipulation instruction.

Figure 17-27. $\overline{\text{SCK0/SCL/P27}}$ Pin Configuration

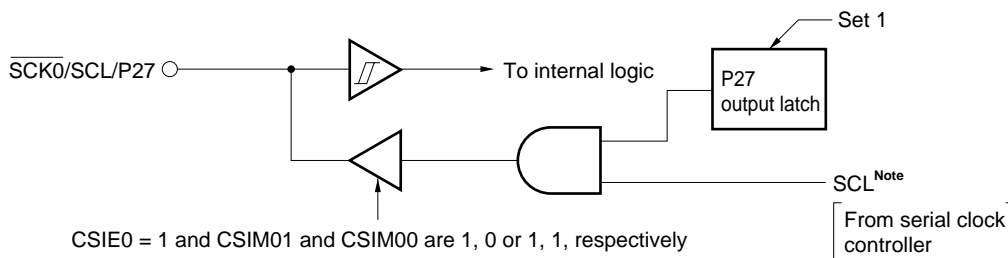


(2) In I²C bus mode

The output level of the $\overline{\text{SCK0/SCL/P27}}$ pin is manipulated by the CLC bit of the interrupt timing specify register (SINT).

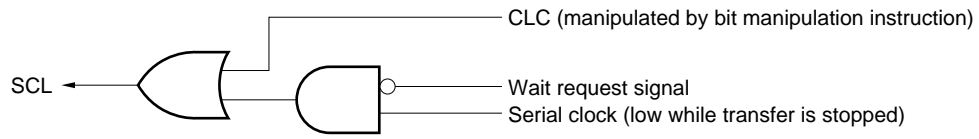
- <1> Set the serial operating mode register 0 (CSIM0) (SCL pin is set in the output mode and serial operation is enabled). Set 1 to the P27 output latch. $\text{SCL} = 0$ while serial transfer is stopped.
- <2> Manipulate the CLC bit of SINT by executing the bit manipulation instruction.

Figure 17-28. $\overline{\text{SCK0/SCL/P27}}$ Pin Configuration



Note The level of the SCL signal is in accordance with the contents of the logic circuits shown in Figure 17-29.

Figure 17-29. Logic Circuit of SCL Signal



- Remarks**
1. This figure indicates the relation of the signals and does not indicate the internal circuit.
 2. CLC: Bit 3 of interrupt timing specify register (SINT)

[MEMO]

CHAPTER 18 SERIAL INTERFACE CHANNEL 1

18.1 Serial Interface Channel 1 Functions

Serial interface channel 1 employs the following three modes.

- Operation stop mode
- 3-wire serial I/O mode
- 3-wire serial I/O mode with automatic transmit/receive function

(1) Operation stop mode

This mode is used when serial transfer is not carried out to reduce power consumption.

(2) 3-wire serial I/O mode (MSB-/LSB-first switchable)

This mode is used for 8-bit data transfer using three lines, each for serial clock ($\overline{SCK1}$), serial output (SO1) and serial input (SI1).

The 3-wire serial I/O mode enables simultaneous transmission/reception and so decreases the data transfer processing time.

Since the start bit of 8-bit data to undergo serial transfer is switchable between MSB and LSB, connection is enabled with either start bit device.

The 3-wire serial I/O mode is valid for connection of peripheral I/O units and display controllers which incorporate a conventional synchronous serial interface such as the 75X/XL, 78K and 17K series.

(3) 3-wire serial I/O mode with automatic transmit/receive function (MSB-/LSB-first switchable)

The mode of the same function as (2) 3-wire serial I/O mode added with the automatic transmit/receive function.

The automatic transmit/receive function is used to transmit/receive data with a maximum of 32 bytes. This function enables the hardware to transmit/receive data to/from the OSD (On Screen Display) device and a device with built-in display controller/driver independently of the CPU, thus the software load can be alleviated.

18.2 Serial Interface Channel 1 Configuration

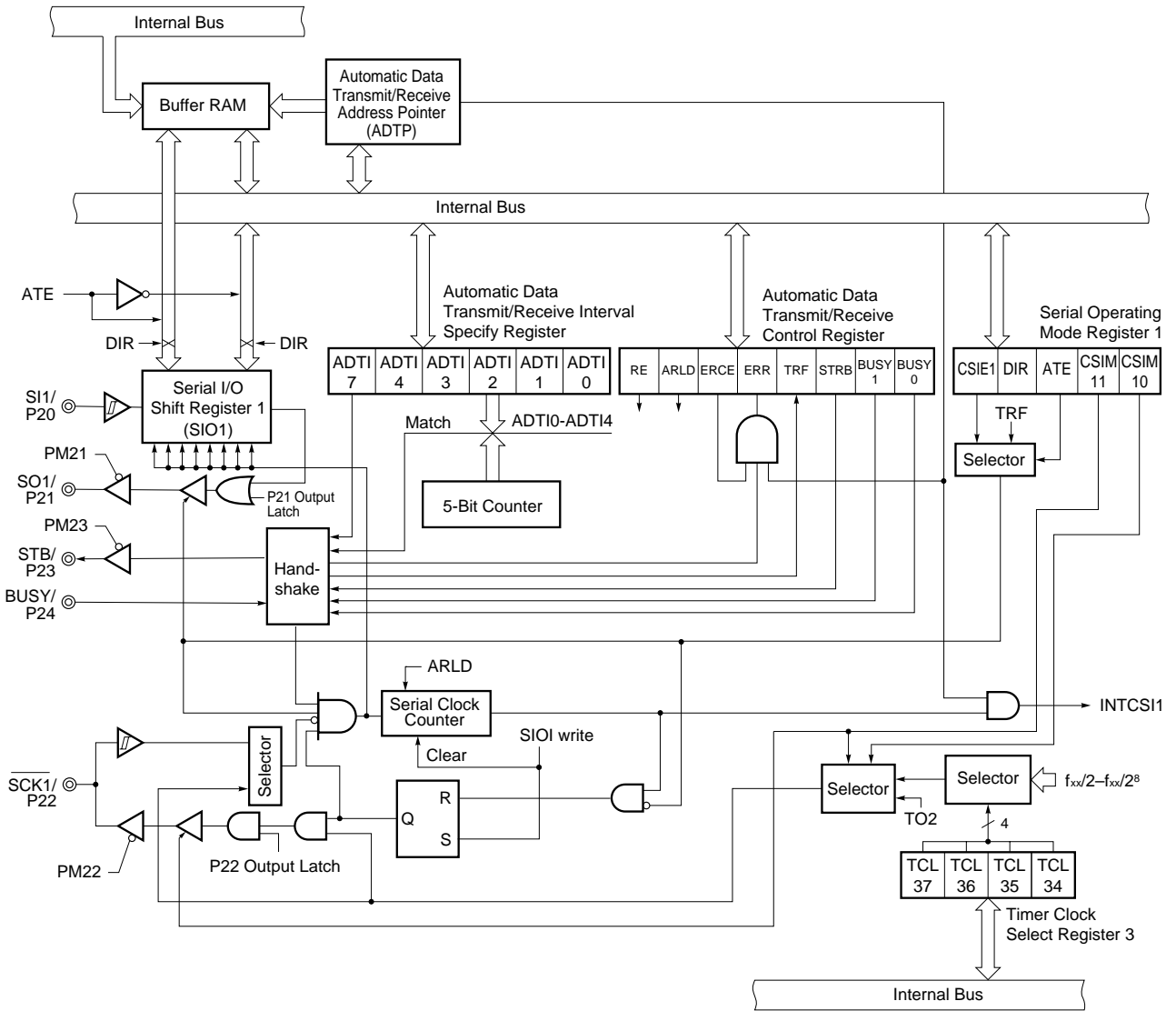
Serial interface channel 1 consists of the following hardware.

Table 18-1. Serial Interface Channel 1 Configuration

Item	Configuration
Register	Serial I/O shift register 1 (SIO1) Automatic data transmit/receive address pointer (ADTP)
Control register	Timer clock select register 3 (TCL3) Serial operating mode register 1 (CSIM1) Automatic data transmit/receive control register (ADTC) Automatic data transmit/receive interval specify register (ADTI) Port mode register 2 (PM2) ^{Note}

Note Refer to Figure 6-5, 6-7 Block Diagram of P20, P21, P23 to P26 and Figure 6-6, 6-8 Block Diagram of P22, P27.

Figure 18-1. Serial Interface Channel 1 Block Diagram



(1) Serial I/O shift register 1 (SIO1)

This is an 8-bit register to carry out parallel/serial conversion and to carry out serial transmission/reception (shift operation) in synchronization with the serial clock.

SIO1 is set with an 8-bit memory manipulation instruction.

When the value in bit 7 (CSIE1) of serial operating mode register 1 (CSIM1) is 1, writing data to SIO1 starts serial operation.

In transmission, data written to SIO1 is output to the serial output (SO1). In reception, data is read from the serial input (SI1) to SIO1.

$\overline{\text{RESET}}$ input makes SIO1 undefined.

Caution Do not write data to SIO1 while the automatic transmit/receive function is activated.

(2) Automatic data transmit/receive address pointer (ADTP)

This register stores value of (the number of transmit data bytes-1) while the automatic transmit/receive function is activated. As data is transferred/received, it is automatically decremented.

ADTP is set with an 8-bit memory manipulation instruction. The high-order 3 bits must be set to 0.

$\overline{\text{RESET}}$ input sets ADTP to 00H.

Caution Do not write data to ADTP while the automatic transmit/receive function is activated.

(3) Serial clock counter

This counter counts the serial clocks to be output and input during transmission/reception to check whether 8-bit data has been transmitted/received.

18.3 Serial Interface Channel 1 Control Registers

The following four types of registers are used to control serial interface channel 1.

- Timer clock select register 3 (TCL3)
- Serial operating mode register 1 (CSIM1)
- Automatic data transmit/receive control register (ADTC)
- Automatic data transmit/receive interval specify register (ADTI)

(1) Timer clock select register 3 (TCL3)

This register sets the serial clock of serial interface channel 1.

TCL3 is set with an 8-bit memory manipulation instruction.

$\overline{\text{RESET}}$ input sets TCL3 to 88H.

Remark Besides setting the serial clock of serial interface channel 1, TCL3 sets the serial clock of serial interface channel 0.

Figure 18-2. Timer Clock Select Register 3 Format

Symbol	7	6	5	4	3	2	1	0	Address	After Reset	R/W
TCL3	TCL37	TCL36	TCL35	TCL34	TCL33	TCL32	TCL31	TCL30	FF43H	88H	R/W

TCL37				TCL36				TCL35				TCL34				Serial Interface Channel 1 Serial Clock Selection		
																MCS = 1		MCS = 0
0	1	1	0	$f_{xx}/2$	Setting prohibited				$f_x/2^2$ (1.25 MHz)									
0	1	1	1	$f_{xx}/2^2$	$f_x/2^2$ (1.25 MHz)				$f_x/2^3$ (625 kHz)									
1	0	0	0	$f_{xx}/2^3$	$f_x/2^3$ (625 kHz)				$f_x/2^4$ (313 kHz)									
1	0	0	1	$f_{xx}/2^4$	$f_x/2^4$ (313 kHz)				$f_x/2^5$ (156 kHz)									
1	0	1	0	$f_{xx}/2^5$	$f_x/2^5$ (156 kHz)				$f_x/2^6$ (78.1 kHz)									
1	0	1	1	$f_{xx}/2^6$	$f_x/2^6$ (78.1 kHz)				$f_x/2^7$ (39.1 kHz)									
1	1	0	0	$f_{xx}/2^7$	$f_x/2^7$ (39.1 kHz)				$f_x/2^8$ (19.5 kHz)									
1	1	0	1	$f_{xx}/2^8$	$f_x/2^8$ (19.5 kHz)				$f_x/2^9$ (9.8 kHz)									
Other than above				Setting prohibited														

Caution When rewriting other data to TCL3 , stop the serial transfer operation beforehand.

- Remarks**
1. f_{xx} : Main system clock frequency (f_x or $f_x/2$)
 2. f_x : Main system clock oscillation frequency
 3. MCS : Bit 0 of oscillation mode selection register (OSMS)
 4. Figures in parentheses apply to operation with $f_x = 5.0$ MHz

(2) Serial operating mode register 1 (CSIM1)

This register sets serial interface channel 1 serial clock, operating mode, operation enable/stop and automatic transmit/receive operation enable/stop.

CSIM1 is set with a 1-bit or 8-bit memory manipulation instruction.

RESET input sets CSIM1 to 00H.

Figure 18-3. Serial Operation Mode Register 1 Format

Symbol	<7>	6	<5>	4	3	2	1	0	Address	After Reset	R/W
CSIM1	CSIE1	DIR	ATE	0	0	0	CSIM11	CSIM10	FF68H	00H	R/W

CSIM11	CSIM10	Serial Interface Channel 1 Clock Selection
0	x	Clock externally input to $\overline{\text{SCK1}}$ pin ^{Note 1}
1	0	8-bit timer register 2 (TM2) output
1	1	Clock specified with bits 4 to 7 of timer clock select register 3 (TCL3)

ATE	Serial Interface Channel 1 Operating Mode Selection
0	3-wire serial I/O mode
1	3-wire serial I/O mode with automatic transmit/receive function

DIR	Start Bit	SI1 Pin Function	SO1 Pin Function
0	MSB	SI1/P20 (Input)	SO1 (CMOS output)
1	LSB		

CSIE1	CSIM11	PM20	P20	PM21	P21	PM22	P22	Shift Register 1 Operation	Serial Clock Counter Operation Control	SI1/P20 Pin Function	SO1/P21 Pin Function	$\overline{\text{SCK1}}$ /P22 Pin Function
0	x	^{Note 2} x	^{Note 2} x	^{Note 2} x	^{Note 2} x	^{Note 2} x	^{Note 2} x	Operation stop	Clear	P20 (CMOS input/output)	P21 (CMOS input/output)	P22 (CMOS input/output)
1	0	^{Note 3} 1	^{Note 3} x	0	0	1	x	Operation enable	Count operation	SI1 ^{Note 3} (input)	SO1 (CMOS output)	$\overline{\text{SCK1}}$ (Input)
	1				0	1	$\overline{\text{SCK1}}$ (CMOS output)					

- Notes**
1. If the external clock input has been selected with CSIM11 set to 0, set bit 1 (BUSY1) and bit 2 (STRB) of the automatic data transmit/receive control register (ADTC) to 0, 0.
 2. Can be used freely as port function.
 3. Can be used as P20 (CMOS input/output) when only transmitter is used (clear bit 7 (RE) of ADTC to 0).

Remark

- x : Don't care
- PMxx : Port mode register
- Pxx : Port output latch

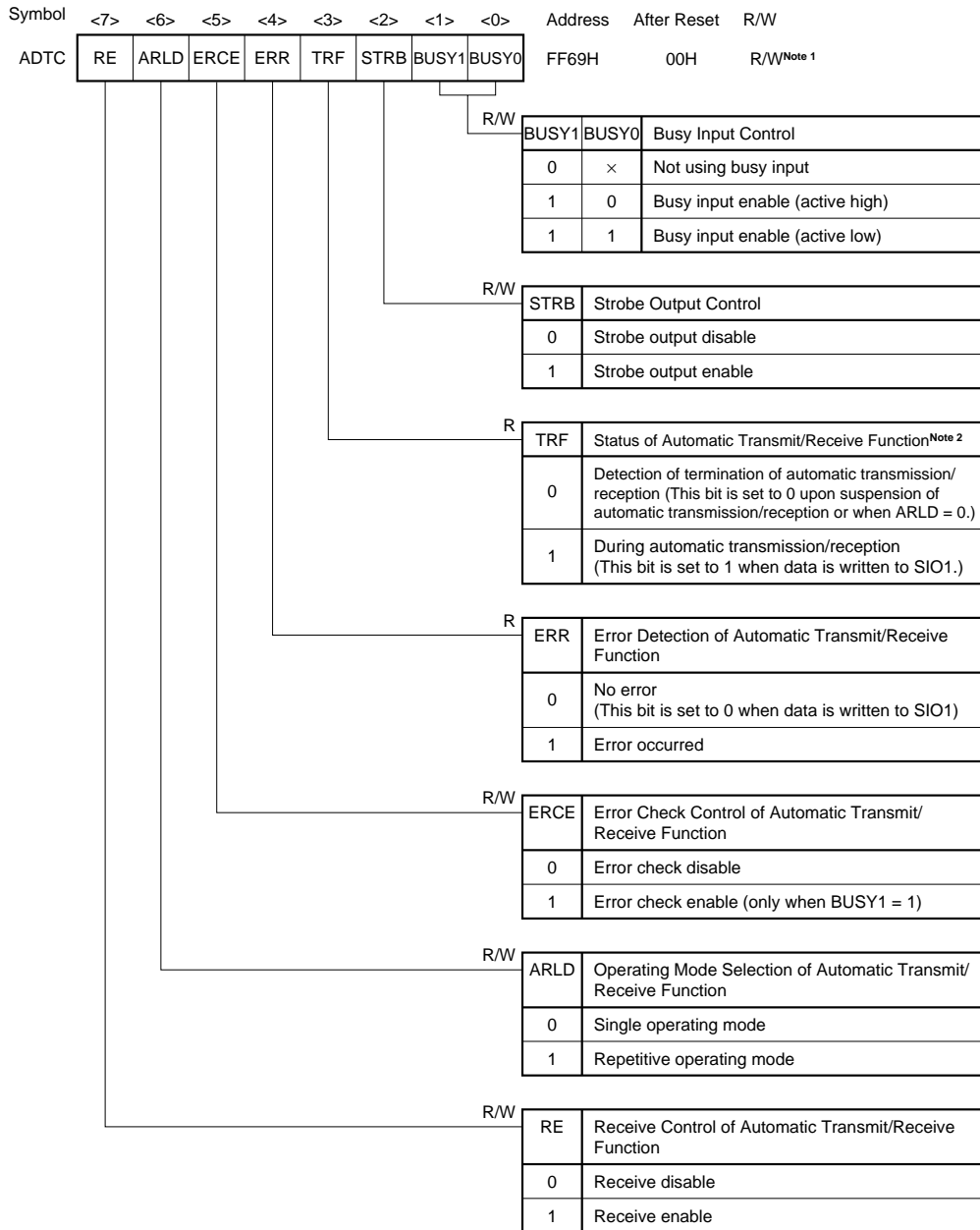
(3) Automatic data transmit/receive control register (ADTC)

This register sets automatic transmit/receive enable/disable, the operating mode, strobe output enable/disable, busy input enable/disable, error check enable/disable and displays automatic transmit/receive execution and error detection.

ADTC is set with a 1-bit or 8-bit memory manipulation instruction.

$\overline{\text{RESET}}$ input sets ADTC to 00H.

Figure 18-4. Automatic Data Transmit/Receive Control Register Format



Notes 1. Bits 3 and 4 (TRF and ERR) are Read-Only bits.

2. The termination of automatic transmission/reception should be discriminated by using TRF, not CSIF1 (Interrupt request flag).

Caution When an external clock input is selected with bit 1 (CSIM11) of the serial operating mode register 1 (CSIM1) set to 0, set STRB and BUSY1 of ADTC to 0, 0 (When an external clock is input, hand shake control cannot be performed).

Remark x: Don't care

(4) Automatic data transmit/receive interval specify register (ADTI)

This register sets the automatic data transmit/receive function data transfer interval.

ADTI is set by a 1-bit or 8-bit memory manipulation instruction.

$\overline{\text{RESET}}$ input sets ADTI to 00H.

Figure 18-5. Automatic Data Transmit/Receive Interval Specify Register Format (1/4)

Symbol	7	6	5	4	3	2	1	0	Address	After Reset	R/W
ADTI	ADTI7	0	0	ADTI4	ADTI3	ADTI2	ADTI1	ADTI0	FF6BH	00H	R/W

ADTI7	Data Transfer Interval Control
0	No control of interval by ADTI ^{Note 1}
1	Control of interval by ADTI (ADTI0 to ADTI4)

ADTI4	ADTI3	ADTI2	ADTI1	ADTI0	Data Transfer Interval Specification (f _{xx} = 5.0 MHz Operation)	
					Minimum ^{Note 2}	Maximum ^{Note 2}
0	0	0	0	0	18.4 μs + 0.5/f _{sck}	20.0 μs + 1.5/f _{sck}
0	0	0	0	1	31.2 μs + 0.5/f _{sck}	32.8 μs + 1.5/f _{sck}
0	0	0	1	0	44.0 μs + 0.5/f _{sck}	45.6 μs + 1.5/f _{sck}
0	0	0	1	1	56.8 μs + 0.5/f _{sck}	58.4 μs + 1.5/f _{sck}
0	0	1	0	0	69.6 μs + 0.5/f _{sck}	71.2 μs + 1.5/f _{sck}
0	0	1	0	1	82.4 μs + 0.5/f _{sck}	84.0 μs + 1.5/f _{sck}
0	0	1	1	0	95.2 μs + 0.5/f _{sck}	96.8 μs + 1.5/f _{sck}
0	0	1	1	1	108.0 μs + 0.5/f _{sck}	109.6 μs + 1.5/f _{sck}
0	1	0	0	0	120.8 μs + 0.5/f _{sck}	122.4 μs + 1.5/f _{sck}
0	1	0	0	1	133.6 μs + 0.5/f _{sck}	135.2 μs + 1.5/f _{sck}
0	1	0	1	0	146.4 μs + 0.5/f _{sck}	148.0 μs + 1.5/f _{sck}
0	1	0	1	1	159.2 μs + 0.5/f _{sck}	160.8 μs + 1.5/f _{sck}
0	1	1	0	0	172.0 μs + 0.5/f _{sck}	173.6 μs + 1.5/f _{sck}
0	1	1	0	1	184.8 μs + 0.5/f _{sck}	186.4 μs + 1.5/f _{sck}
0	1	1	1	0	197.6 μs + 0.5/f _{sck}	199.2 μs + 1.5/f _{sck}
0	1	1	1	1	210.4 μs + 0.5/f _{sck}	212.0 μs + 1.5/f _{sck}

Notes 1. The interval is dependent only on CPU processing.

2. The data transfer interval includes an error. The data transfer minimum and maximum intervals are found from the following expressions (n: Value set in ADTI0 to ADTI4). However, if a minimum which is calculated by the following expressions is smaller than 2/f_{sck}, the minimum interval time is 2/f_{sck}.

$$\text{Minimum} = (n+1) \times \frac{2^6}{f_{xx}} + \frac{28}{f_{xx}} + \frac{0.5}{f_{sck}}, \text{ Maximum} = (n+1) \times \frac{2^6}{f_{xx}} + \frac{36}{f_{xx}} + \frac{1.5}{f_{sck}}$$

Cautions 1. Do not write ADTI during operation of automatic data transmit/receive function.

2. Bits 5 and 6 must be set to zero.

3. To control the data transfer interval by means of automatic transmission/reception with ADTI, busy control (refer to 18.4.3 (4) (a) Busy control option) is disabled.

Remarks 1. f_{xx} : Main system clock frequency (fx or fx/2)

2. fx : Main system clock oscillation frequency

3. f_{sck} : Serial clock frequency

Figure 18-5. Automatic Data Transmit/Receive Interval Specify Register Format (2/4)

Symbol	7	6	5	4	3	2	1	0	Address	After Reset	R/W
ADTI	ADTI7	0	0	ADTI4	ADTI3	ADTI2	ADTI1	ADTI0	FF6BH	00H	R/W

ADTI4	ADTI3	ADTI2	ADTI1	ADTI0	Data Transfer Interval Specification (f _{xx} = 5.0 MHz Operation)	
					Minimum ^{Note}	Maximum ^{Note}
1	0	0	0	0	223.2 μs + 0.5/f _{sck}	224.8 μs + 1.5/f _{sck}
1	0	0	0	1	236.0 μs + 0.5/f _{sck}	237.6 μs + 1.5/f _{sck}
1	0	0	1	0	248.8 μs + 0.5/f _{sck}	250.4 μs + 1.5/f _{sck}
1	0	0	1	1	261.6 μs + 0.5/f _{sck}	263.2 μs + 1.5/f _{sck}
1	0	1	0	0	274.4 μs + 0.5/f _{sck}	276.0 μs + 1.5/f _{sck}
1	0	1	0	1	287.2 μs + 0.5/f _{sck}	288.8 μs + 1.5/f _{sck}
1	0	1	1	0	300.0 μs + 0.5/f _{sck}	301.6 μs + 1.5/f _{sck}
1	0	1	1	1	312.8 μs + 0.5/f _{sck}	314.4 μs + 1.5/f _{sck}
1	1	0	0	0	325.6 μs + 0.5/f _{sck}	327.2 μs + 1.5/f _{sck}
1	1	0	0	1	338.4 μs + 0.5/f _{sck}	340.0 μs + 1.5/f _{sck}
1	1	0	1	0	351.2 μs + 0.5/f _{sck}	352.8 μs + 1.5/f _{sck}
1	1	0	1	1	364.0 μs + 0.5/f _{sck}	365.6 μs + 1.5/f _{sck}
1	1	1	0	0	376.8 μs + 0.5/f _{sck}	378.4 μs + 1.5/f _{sck}
1	1	1	0	1	389.6 μs + 0.5/f _{sck}	391.2 μs + 1.5/f _{sck}
1	1	1	1	0	402.4 μs + 0.5/f _{sck}	404.0 μs + 1.5/f _{sck}
1	1	1	1	1	415.2 μs + 0.5/f _{sck}	416.8 μs + 1.5/f _{sck}

Note The data transfer interval includes an error. The data transfer minimum and maximum intervals are found from the following expressions (n: Value set in ADTI0 to ADTI4). However, if a minimum which is calculated by the following expressions is smaller than 2/f_{sck}, the minimum interval time is 2/f_{sck}.

$$\text{Minimum} = (n+1) \times \frac{2^6}{f_{xx}} + \frac{28}{f_{xx}} + \frac{0.5}{f_{sck}}$$

$$\text{Maximum} = (n+1) \times \frac{2^6}{f_{xx}} + \frac{36}{f_{xx}} + \frac{1.5}{f_{sck}}$$

- Cautions**
1. Do not write data to ADTI during operation of automatic data transmit/receive function.
 2. Zero must be set in bits 5 and 6.
 3. To control the data transfer interval by means of automatic transmission/reception with ADTI, busy control (refer to 18.4.3 (4) (a) Busy control option) is disabled.

- Remarks**
1. f_{xx} : Main system clock frequency (fx or fx/2)
 2. fx : Main system clock oscillation frequency
 3. f_{sck} : Serial clock frequency

Figure 18-5. Automatic Data Transmit/Receive Interval Specify Register Format (3/4)

Symbol	7	6	5	4	3	2	1	0	Address	After Reset	R/W
ADTI	ADTI7	0	0	ADTI4	ADTI3	ADTI2	ADTI1	ADTI0	FF6BH	00H	R/W

ADTI7	Data Transfer Interval Control
0	No control of interval by ADTI ^{Note 1}
1	Control of interval by ADTI (ADTI0 to ADTI4)

ADTI4	ADTI3	ADTI2	ADTI1	ADTI0	Data Transfer Interval Specification (f _{xx} = 2.5 MHz Operation)	
					Minimum ^{Note 2}	Maximum ^{Note 2}
0	0	0	0	0	36.8 μs + 0.5/f _{sck}	40.0 μs + 1.5/f _{sck}
0	0	0	0	1	62.4 μs + 0.5/f _{sck}	65.6 μs + 1.5/f _{sck}
0	0	0	1	0	88.0 μs + 0.5/f _{sck}	91.2 μs + 1.5/f _{sck}
0	0	0	1	1	113.6 μs + 0.5/f _{sck}	116.8 μs + 1.5/f _{sck}
0	0	1	0	0	139.2 μs + 0.5/f _{sck}	142.4 μs + 1.5/f _{sck}
0	0	1	0	1	164.8 μs + 0.5/f _{sck}	168.0 μs + 1.5/f _{sck}
0	0	1	1	0	190.4 μs + 0.5/f _{sck}	193.6 μs + 1.5/f _{sck}
0	0	1	1	1	216.0 μs + 0.5/f _{sck}	219.2 μs + 1.5/f _{sck}
0	1	0	0	0	241.6 μs + 0.5/f _{sck}	244.8 μs + 1.5/f _{sck}
0	1	0	0	1	267.2 μs + 0.5/f _{sck}	270.4 μs + 1.5/f _{sck}
0	1	0	1	0	292.8 μs + 0.5/f _{sck}	296.0 μs + 1.5/f _{sck}
0	1	0	1	1	318.4 μs + 0.5/f _{sck}	321.6 μs + 1.5/f _{sck}
0	1	1	0	0	344.0 μs + 0.5/f _{sck}	347.2 μs + 1.5/f _{sck}
0	1	1	0	1	369.6 μs + 0.5/f _{sck}	372.8 μs + 1.5/f _{sck}
0	1	1	1	0	395.2 μs + 0.5/f _{sck}	398.4 μs + 1.5/f _{sck}
0	1	1	1	1	420.8 μs + 0.5/f _{sck}	424.0 μs + 1.5/f _{sck}

- Notes**
- The interval is dependent only on CPU processing.
 - The data transfer interval includes an error. The data transfer minimum and maximum intervals are found from the following expressions (n: Value set in ADTI0 to ADTI4). However, if a minimum which is calculated by the following expressions is smaller than 2/f_{sck}, the minimum interval time is 2/f_{sck}.

$$\text{Minimum} = (n+1) \times \frac{2^6}{f_{xx}} + \frac{28}{f_{xx}} + \frac{0.5}{f_{sck}}$$

$$\text{Maximum} = (n+1) \times \frac{2^6}{f_{xx}} + \frac{36}{f_{xx}} + \frac{1.5}{f_{sck}}$$

- Cautions**
- Do not write data to ADTI during operation of automatic data transmit/receive function.
 - Bits 5 and 6 must be set to zero.
 - To control the data transfer interval by means of automatic transmission/reception with ADTI, busy control (refer to 18.4.3 (4) (a) Busy control option) is disabled.

- Remarks**
- f_{xx} : Main system clock frequency (f_x or f_x/2)
 - f_x : Main system clock oscillation frequency
 - f_{sck} : Serial clock frequency

Figure 18-5. Automatic Data Transmit/Receive Interval Specify Register Format (4/4)

Symbol	7	6	5	4	3	2	1	0	Address	After Reset	R/W
ADTI	ADTI7	0	0	ADTI4	ADTI3	ADTI2	ADTI1	ADTI0	FF6BH	00H	R/W

ADTI4	ADTI3	ADTI2	ADTI1	ADTI0	Data Transfer Interval Specification (f _{xx} = 2.5 MHz Operation)	
					Minimum ^{Note}	Maximum ^{Note}
1	0	0	0	0	446.4 μs + 0.5/f _{sck}	449.6 μs + 1.5/f _{sck}
1	0	0	0	1	472.0 μs + 0.5/f _{sck}	475.2 μs + 1.5/f _{sck}
1	0	0	1	0	497.6 μs + 0.5/f _{sck}	500.8 μs + 1.5/f _{sck}
1	0	0	1	1	523.2 μs + 0.5/f _{sck}	526.4 μs + 1.5/f _{sck}
1	0	1	0	0	548.8 μs + 0.5/f _{sck}	552.0 μs + 1.5/f _{sck}
1	0	1	0	1	574.4 μs + 0.5/f _{sck}	577.6 μs + 1.5/f _{sck}
1	0	1	1	0	600.0 μs + 0.5/f _{sck}	603.2 μs + 1.5/f _{sck}
1	0	1	1	1	625.6 μs + 0.5/f _{sck}	628.8 μs + 1.5/f _{sck}
1	1	0	0	0	651.2 μs + 0.5/f _{sck}	654.4 μs + 1.5/f _{sck}
1	1	0	0	1	676.8 μs + 0.5/f _{sck}	680.0 μs + 1.5/f _{sck}
1	1	0	1	0	702.4 μs + 0.5/f _{sck}	705.6 μs + 1.5/f _{sck}
1	1	0	1	1	728.0 μs + 0.5/f _{sck}	731.2 μs + 1.5/f _{sck}
1	1	1	0	0	753.6 μs + 0.5/f _{sck}	756.8 μs + 1.5/f _{sck}
1	1	1	0	1	779.2 μs + 0.5/f _{sck}	782.4 μs + 1.5/f _{sck}
1	1	1	1	0	804.8 μs + 0.5/f _{sck}	808.0 μs + 1.5/f _{sck}
1	1	1	1	1	830.4 μs + 0.5/f _{sck}	833.6 μs + 1.5/f _{sck}

Note The data transfer interval includes an error. The data transfer minimum and maximum intervals are found from the following expressions (n: Value set in ADTI0 to ADTI4). However, if a minimum which is calculated by the following expressions is smaller than 2/f_{sck}, the minimum interval time is 2/f_{sck}.

$$\text{Minimum} = (n+1) \times \frac{2^6}{f_{xx}} + \frac{28}{f_{xx}} + \frac{0.5}{f_{sck}}$$

$$\text{Maximum} = (n+1) \times \frac{2^6}{f_{xx}} + \frac{36}{f_{xx}} + \frac{1.5}{f_{sck}}$$

- Cautions**
1. Do not write data to ADTI during operation of automatic data transmit/receive function.
 2. Bits 5 and 6 must be set to zero.
 3. To control the data transfer interval by means of automatic transmission/reception with ADTI, busy control (refer to 18.4.3 (4) (a) Busy control option) is disabled.

- Remarks**
1. f_{xx} : Main system clock frequency (fx or fx/2)
 2. fx : Main system clock oscillation frequency
 3. f_{sck} : Serial clock frequency

18.4 Serial Interface Channel 1 Operations

The following three operating modes are available to the serial interface channel 1.

- Operation stop mode
- 3-wire serial I/O mode
- 3-wire serial I/O mode with automatic transmit/receive function

18.4.1 Operation stop mode

Serial transfer is not carried out in the operation stop mode. Thus, power consumption can be reduced. The serial I/O shift register 1 (SIO1) does not carry out shift operation either, and thus it can be used as an ordinary 8-bit register.

In the operation stop mode, the P20/SI1, P21/SO1, P22/ $\overline{SCK1}$, P23/STB and P24/BUSY pins can be used as ordinary input/output ports.

(1) Register setting

The operation stop mode is set with the serial operating mode register 1 (CSIM1).

CSIM1 is set with a 1-bit or 8-bit memory manipulation instruction.

\overline{RESET} input sets CSIM1 to 00H.

Symbol	<7>	6	<5>	4	3	2	1	0	Address	After Reset	R/W
CSIM1	CSIE1	DIR	ATE	0	0	0	CSIM11	CSIM10	FF68H	00H	R/W

CSIE1	CSIM11	PM20	P20	PM21	P21	PM22	P22	Shift Register 1 Operation	Serial Clock Counter Operation Control	SI1/P20 Pin Function	SO1/P21 Pin Function	$\overline{SCK1}$ /P22 Pin Function
0	×	Note 1 ×	Note 1 ×	Note 1 ×	Note 1 ×	Note 1 ×	Note 1 ×	Operation stop	Clear	P20 (CMOS input/output)	P21 (CMOS input/output)	P22 (CMOS input/output)
1	0	Note 2 1	Note 2 ×	0	0	1	×	Operation enable	Count operation	SI1 Note 2 (Input)	SO1 (CMOS output)	$\overline{SCK1}$ (Input)
	0					1	$\overline{SCK1}$ (CMOS output)					

Notes 1. Can be used freely as port function.

2. Can be used as P20 (CMOS input/output) when only transmitter is used (clear bit 7 (RE) of the automatic data transmit/receive control register (ADTC) to 0).

Remark × : Don't care
 PMxx : Port mode register
 Pxx : Port output latch

18.4.2 3-wire serial I/O mode operation

The 3-wire serial I/O mode is valid for connection of peripheral I/O units and display controllers which incorporate a conventional synchronous serial interface such as the 75X/XL, 78K and 17K series.

Communication is carried out with three lines of serial clock ($\overline{SCK1}$), serial output (SO1) and serial input (SI1).

(1) Register setting

The 3-wire serial I/O mode is set with the serial operating mode register 1 (CSIM1).

CSIM1 is set with a 1-bit or 8-bit memory manipulation instruction.

\overline{RESET} input sets CSIM1 to 00H.

Symbol	<7>	6	<5>	4	3	2	1	0	Address	After Reset	R/W
CSIM1	CSIE1	DIR	ATE	0	0	0	CSIM11	CSIM10	FF68H	00H	R/W

CSIM11	CSIM10	Serial Interface Channel 1 Clock Selection
0	×	Clock externally input to $\overline{SCK1}$ pin ^{Note}
1	0	8-bit timer register 2 (TM2) output
1	1	Clock specified with bits 4 to 7 of timer clock select register 3 (TCL3)

ATE	Serial Interface Channel 1 Operating Mode Selection
0	3-wire serial I/O mode
1	3-wire serial I/O mode with automatic transmit/receive function

DIR	Start Bit	SO1 Pin Function	SO1 Pin Function
0	MSB	SI1/P20 (Input)	SO1 (CMOS output)
1	LSB		

Note If the external clock input has been selected with CSIM11 set to 0, set bit 1 (BUSY1) and bit 2 (STRB) of the automatic data transmit/receive control register (ADTC) to 0, 0.

Remark ×: Don't care

CSIE1	CSIM11	PM20	P20	PM21	P21	PM22	P22	Shift Register 1 Operation	Serial Clock Counter Operation Control	SI1/P20 Pin Function	SO1/P21 Pin Function	$\overline{SCK1}$ /P22 Pin Function
0	×	Note 1 ×	Note 1 ×	Note 1 ×	Note 1 ×	Note 1 ×	Note 1 ×	Operation stop	Clear	P20 (CMOS input/output)	P21 (CMOS input/output)	P22 (CMOS input/output)
1	0	Note 2 1	Note 2 ×	0	0	1	×	Operation enable	Count operation	SI1 ^{Note 2} (Input)	SO1 (CMOS output)	$\overline{SCK1}$ (Input)
	0					1	$\overline{SCK1}$ (CMOS output)					

- Notes**
1. Can be used freely as port function.
 2. Can be used as P20 (CMOS input/output) when only transmitter is used (clear bit 7 (RE) of ADTC to 0).

Remark

- × : Don't care
- PM×× : Port mode register
- P×× : Port output latch

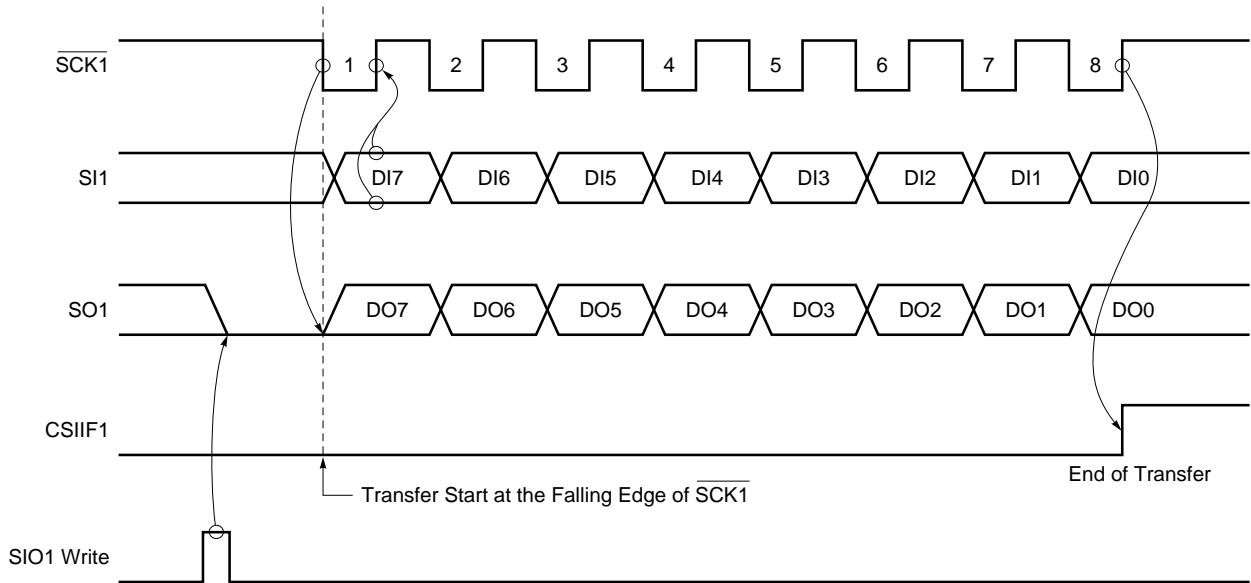
(2) Communication operation

The 3-wire serial I/O mode is used for data transmission/reception in 8-bit units. Bit-wise data transmission/reception is carried out in synchronization with the serial clock.

Shift operation of the serial I/O shift register 1 (SIO1) is carried out at the falling edge of the serial clock $\overline{SCK1}$. The transmit data is held in the SO1 latch and is output from the SO1 pin. The receive data input to the SI1 pin is latched into SIO1 at the rising edge of $\overline{SCK1}$.

Upon termination of 8-bit transfer, the SIO1 operation stops automatically and the interrupt request flag (CSIF1) is set.

Figure 18-6. 3-Wire Serial I/O Mode Timings



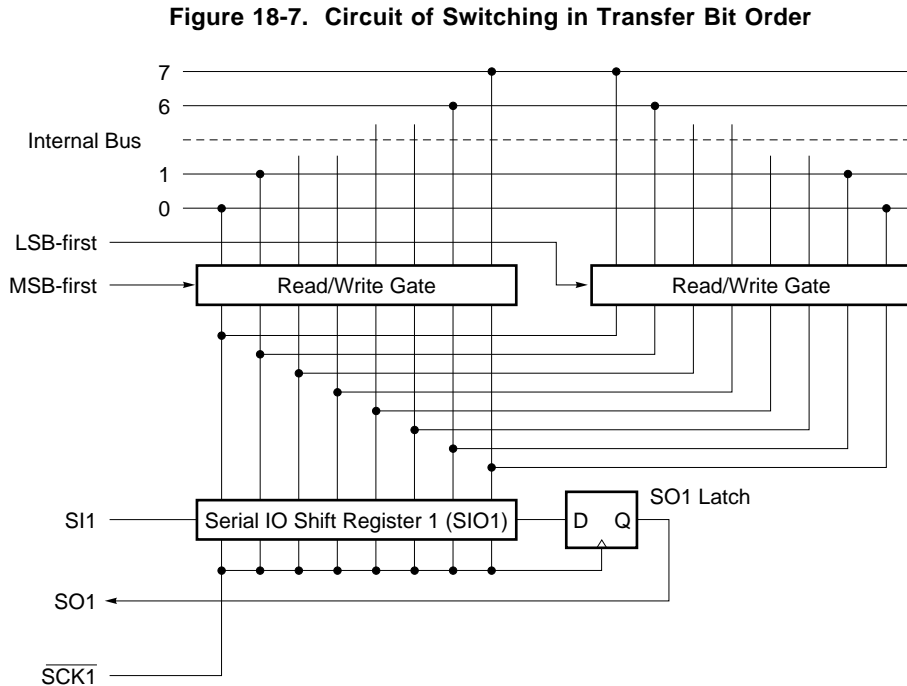
Caution SO1 pin becomes low level by SIO1 write.

(3) MSB/LSB switching as the start bit

The 3-wire serial I/O mode enables to select transfer to start from MSB or LSB.

Figure 18-7 shows the configuration of the serial I/O shift register 1 (SIO1) and internal bus. As shown in the figure, MSB/LSB can be read/written in reverse form.

MSB/LSB switching as the start bit can be specified with bit 6 (DIR) of the serial operating mode register 1 (CSIM1).



Start bit switching is realized by switching the bit order for data write to SIO1. The SIO1 shift order remains unchanged.

Thus, switching between MSB-first and LSB-first must be performed before writing data to the SIO1.

(4) Transfer start

Serial transfer is started by setting transfer data to the serial I/O shift register 1 (SIO1) when the following two conditions are satisfied.

- Serial interface channel 1 operation control bit (CSIE1) = 1
- Internal serial clock is stopped or $\overline{\text{SCK1}}$ is a high level after 8-bit serial transfer.

Caution If CSIE1 is set to "1" after data write to SIO1, transfer does not start.

Upon termination of 8-bit transfer, serial transfer automatically stops and the interrupt request flag (CSIIF1) is set.

18.4.3 3-wire serial I/O mode operation with automatic transmit/receive function

This 3-wire serial I/O mode is used for transmission/reception of a maximum of 32-byte data without the use of software. Once transfer is started, the data prestored in the RAM can be transmitted by the set number of bytes, and data can be received and stored in the RAM by the set number of bytes.

Handshake signals (STB and BUSY) are supported by hardware to transmit/receive data continuously. OSD (On Screen Display) LSI and peripheral LSI including LCD controller/driver can be connected without difficulty.

(1) Register setting

The 3-wire serial I/O mode with automatic transmit/receive function is set with the serial operating mode register 1 (CSIM1), the automatic data transmit/receive control register (ADTC) and the automatic data transmit/receive interval specify register (ADTI).

(a) Serial operating mode register 1 (CSIM1)

CSIM1 is set with a 1-bit or 8-bit memory manipulation instruction.

$\overline{\text{RESET}}$ input sets CSIM1 to 00H.

Symbol	<7>	6	<5>	4	3	2	1	0	Address	After Reset	R/W
CSIM1	CSIE1	DIR	ATE	0	0	0	CSIM11	CSIM10	FF68H	00H	R/W

CSIM11	CSIM10	Serial Interface Channel 1 Clock Selection
0	×	Clock externally input to $\overline{\text{SCK1}}$ pin ^{Note 1}
1	0	8-bit timer register 2 (TM2) output
1	1	Clock specified with bits 4 to 7 of timer clock select register 3 (TCL3)

ATE	Serial Interface Channel 1 Operating Mode Selection
0	3-wire serial I/O mode
1	3-wire serial I/O mode with automatic transmit/receive function

DIR	Start Bit	SI1 Pin Function	SO1 Pin Function
0	MSB	SI1/P20 (Input)	SO1 (CMOS output)
1	LSB		

CSIE1	CSIM11	PM20	P20	PM21	P21	PM22	P22	Shift Register 1 Operation	Serial Clock Counter Operation Control	SI1/P20 Pin Function	SO1/P21 Pin Function	$\overline{\text{SCK1}}$ /P22 Pin Function
0	×	^{Note 2} ×	^{Note 2} ×	^{Note 2} ×	^{Note 2} ×	^{Note 2} ×	^{Note 2} ×	Operation stop	Clear	P20 (CMOS input/output)	P21 (CMOS input/output)	P22 (CMOS input/output)
1	0	^{Note 3} 1	^{Note 3} ×	0	0	1	×	Operation enable	Count operation	SI1 ^{Note 3} (Input)	SO1 (CMOS output)	$\overline{\text{SCK1}}$ (Input)
	1				0	1	$\overline{\text{SCK1}}$ (CMOS output)					

- Notes**
1. If the external clock input has been selected with CSIM11 set to 0, set bit 1 (BUSY 1) and bit 2 (STRB) of the automatic data transmit/receive control register (ADTC) to 0, 0.
 2. Can be used freely as port function.
 3. Can be used as P20 (CMOS input/output) when only transmitter is used (clear bit 7 (RE) of ADTC to 0).

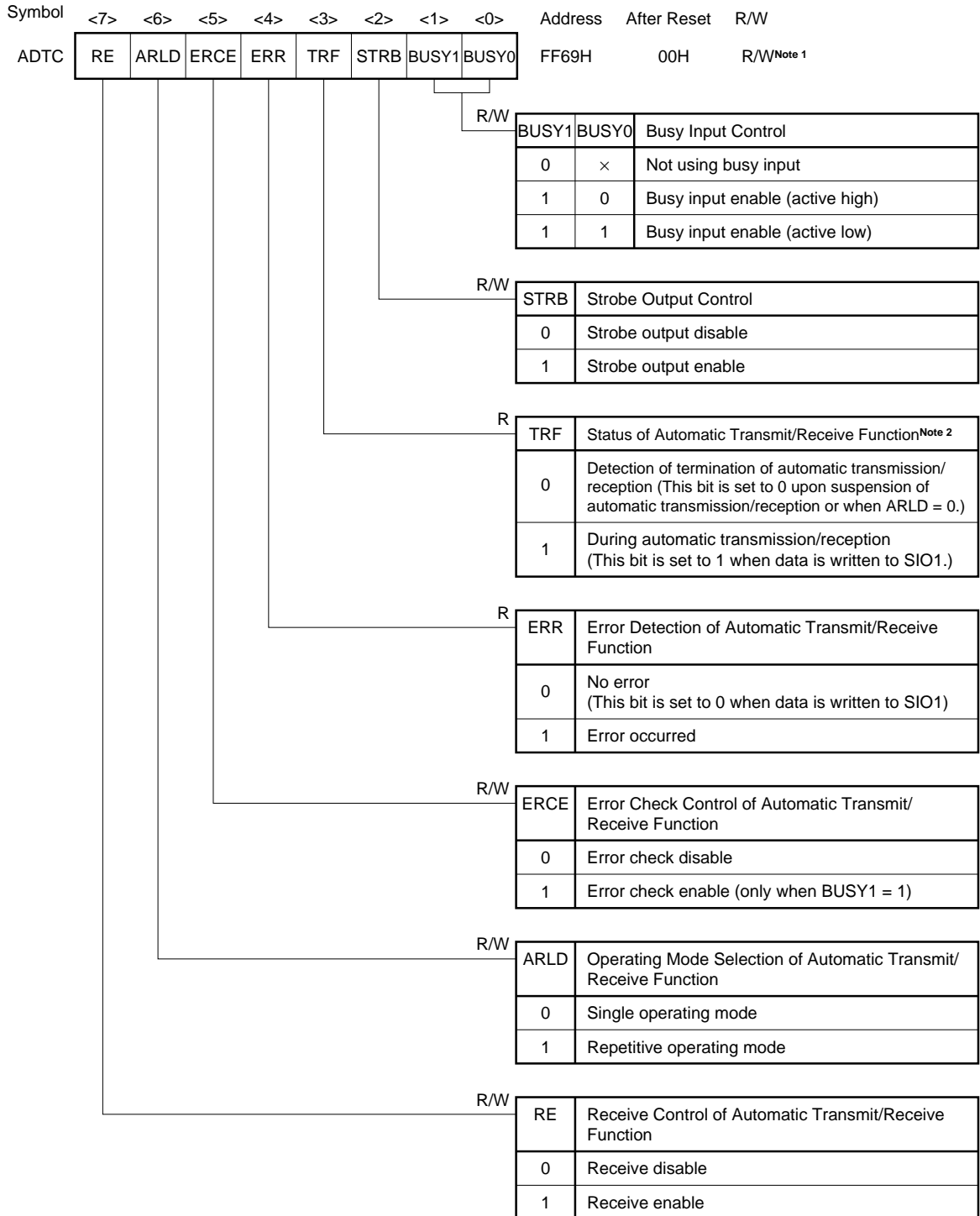
Remark

- × : Don't care
- PMxx: Port mode register
- Pxx : Port output latch

(b) Automatic data transmit/receive control register (ADTC)

ADTC is set with a 1-bit or 8-bit memory manipulation instruction.

$\overline{\text{RESET}}$ input sets ADTC to 00H.



Notes 1. Bits 3 and 4 (TRF and ERR) are Read-Only bits.

2. The termination of automatic transmission/reception should be discriminated by using TRF, not CSIF1 (Interrupt request flag).

Caution When an external clock input is selected with bit 1 (CSIM11) of the serial operating mode register 1 (CSIM1) set to 0, set STRB and BUSY1 of ADTC to 0, 0 (handshake control cannot be executed when the external clock is input).

Remark x: Don't care

(c) Automatic data transmit/receive interval specify register (ADTI)

This register sets the automatic data transmit/receive function data transfer interval.

ADTI is set with a 1-bit or 8-bit memory manipulation instruction. $\overline{\text{RESET}}$ input sets ADTI to 00H.

Symbol	7	6	5	4	3	2	1	0	Address	After Reset	R/W
ADTI	ADTI7	0	0	ADTI4	ADTI3	ADTI2	ADTI1	ADTI0	FF6BH	00H	R/W

ADTI7	Data Transfer Interval Control
0	No control of interval by ADTI ^{Note 1}
1	Control of interval by ADTI (ADTI0 to ADTI4)

ADTI4	ADTI3	ADTI2	ADTI1	ADTI0	Data Transfer Interval Specification (f _{xx} = 5.0 MHz Operation)	
					Minimum ^{Note 2}	Maximum ^{Note 2}
0	0	0	0	0	18.4 μs + 0.5/f _{sck}	20.0 μs + 1.5/f _{sck}
0	0	0	0	1	31.2 μs + 0.5/f _{sck}	32.8 μs + 1.5/f _{sck}
0	0	0	1	0	44.0 μs + 0.5/f _{sck}	45.6 μs + 1.5/f _{sck}
0	0	0	1	1	56.8 μs + 0.5/f _{sck}	58.4 μs + 1.5/f _{sck}
0	0	1	0	0	69.6 μs + 0.5/f _{sck}	71.2 μs + 1.5/f _{sck}
0	0	1	0	1	82.4 μs + 0.5/f _{sck}	84.0 μs + 1.5/f _{sck}
0	0	1	1	0	95.2 μs + 0.5/f _{sck}	96.8 μs + 1.5/f _{sck}
0	0	1	1	1	108.0 μs + 0.5/f _{sck}	109.6 μs + 1.5/f _{sck}
0	1	0	0	0	120.8 μs + 0.5/f _{sck}	122.4 μs + 1.5/f _{sck}
0	1	0	0	1	133.6 μs + 0.5/f _{sck}	135.2 μs + 1.5/f _{sck}
0	1	0	1	0	146.4 μs + 0.5/f _{sck}	148.0 μs + 1.5/f _{sck}
0	1	0	1	1	159.2 μs + 0.5/f _{sck}	160.8 μs + 1.5/f _{sck}
0	1	1	0	0	172.0 μs + 0.5/f _{sck}	173.6 μs + 1.5/f _{sck}
0	1	1	0	1	184.8 μs + 0.5/f _{sck}	186.4 μs + 1.5/f _{sck}
0	1	1	1	0	197.6 μs + 0.5/f _{sck}	199.2 μs + 1.5/f _{sck}
0	1	1	1	1	210.4 μs + 0.5/f _{sck}	212.0 μs + 1.5/f _{sck}

Notes 1. The interval is dependent only on CPU processing.

2. The data transfer interval includes an error. The data transfer minimum and maximum intervals are found from the following expressions (n: Value set in ADTI0 to ADTI4). However, if a minimum which is calculated by the following expressions is smaller than 2/f_{sck}, the minimum interval time is 2/f_{sck}.

$$\text{Minimum} = (n+1) \times \frac{2^6}{f_{xx}} + \frac{28}{f_{xx}} + \frac{0.5}{f_{sck}}, \quad \text{Maximum} = (n+1) \times \frac{26}{f_{xx}} + \frac{36}{f_{xx}} + \frac{1.5}{f_{sck}}$$

Cautions 1. Do not write data to ADTI during operation of automatic data transmit/receive function.

2. Zero must be set in bits 5 and 6.

3. To control the data transfer interval by means of automatic transmission/reception with ADTI, busy control (refer to 18.4.3 (4) (a) Busy control option) is disabled.

Remarks 1. f_{xx} : Main system clock frequency (f_x or f_x/2)

2. f_x : Main system clock oscillation frequency

3. f_{sck} : Serial clock frequency

Symbol	7	6	5	4	3	2	1	0	Address	After Reset	R/W
ADTI	ADTI7	0	0	ADTI4	ADTI3	ADTI2	ADTI1	ADTI0	FF6BH	00H	R/W

ADTI4	ADTI3	ADTI2	ADTI1	ADTI0	Data Transfer Interval Specification (f _{xx} = 5.0 MHz Operation)	
					Minimum ^{Note}	Maximum ^{Note}
1	0	0	0	0	223.2 μs + 0.5/f _{sck}	224.8 μs + 1.5/f _{sck}
1	0	0	0	1	236.0 μs + 0.5/f _{sck}	237.6 μs + 1.5/f _{sck}
1	0	0	1	0	248.8 μs + 0.5/f _{sck}	250.4 μs + 1.5/f _{sck}
1	0	0	1	1	261.6 μs + 0.5/f _{sck}	263.2 μs + 1.5/f _{sck}
1	0	1	0	0	274.4 μs + 0.5/f _{sck}	276.0 μs + 1.5/f _{sck}
1	0	1	0	1	287.2 μs + 0.5/f _{sck}	288.8 μs + 1.5/f _{sck}
1	0	1	1	0	300.0 μs + 0.5/f _{sck}	301.6 μs + 1.5/f _{sck}
1	0	1	1	1	312.8 μs + 0.5/f _{sck}	314.4 μs + 1.5/f _{sck}
1	1	0	0	0	325.6 μs + 0.5/f _{sck}	327.2 μs + 1.5/f _{sck}
1	1	0	0	1	338.4 μs + 0.5/f _{sck}	340.0 μs + 1.5/f _{sck}
1	1	0	1	0	351.2 μs + 0.5/f _{sck}	352.8 μs + 1.5/f _{sck}
1	1	0	1	1	364.0 μs + 0.5/f _{sck}	365.6 μs + 1.5/f _{sck}
1	1	1	0	0	376.8 μs + 0.5/f _{sck}	378.4 μs + 1.5/f _{sck}
1	1	1	0	1	389.6 μs + 0.5/f _{sck}	391.2 μs + 1.5/f _{sck}
1	1	1	1	0	402.4 μs + 0.5/f _{sck}	404.0 μs + 1.5/f _{sck}
1	1	1	1	1	415.2 μs + 0.5/f _{sck}	416.8 μs + 1.5/f _{sck}

Note The data transfer interval includes an error. The data transfer minimum and maximum intervals are found from the following expressions (n: Value set in ADTI0 to ADTI4). However, if a minimum which is calculated by the following expressions is smaller than 2/f_{sck}, the minimum interval time is 2/f_{sck}.

$$\text{Minimum} = (n+1) \times \frac{2^6}{f_{xx}} + \frac{28}{f_{xx}} + \frac{0.5}{f_{sck}}$$

$$\text{Maximum} = (n+1) \times \frac{2^6}{f_{xx}} + \frac{36}{f_{xx}} + \frac{1.5}{f_{sck}}$$

- Cautions**
1. Do not write data to ADTI during operation of automatic data transmit/receive function.
 2. Bits 5 and 6 must be set to zero.
 3. To control the data transfer interval by means of automatic transmission/reception with ADTI, busy control (refer to 18.4.3 (4) (a) Busy control option) is disabled.

- Remarks**
1. f_{xx} : Main system clock frequency (fx or fx/2)
 2. fx : Main system clock oscillation frequency
 3. f_{sck} : Serial clock frequency

Symbol	7	6	5	4	3	2	1	0	Address	After Reset	R/W
ADTI	ADTI7	0	0	ADTI4	ADTI3	ADTI2	ADTI1	ADTI0	FF6BH	00H	R/W

ADTI7	Data Transfer Interval Control
0	No control of interval by ADTI ^{Note 1}
1	Control of interval by ADTI (ADTI0 to ADTI4)

ADTI4	ADTI3	ADTI2	ADTI1	ADTI0	Data Transfer Interval Specification (f _{xx} = 2.5 MHz Operation)	
					Minimum ^{Note 2}	Maximum ^{Note 2}
0	0	0	0	0	36.8 μs + 0.5/f _{sck}	40.0 μs + 1.5/f _{sck}
0	0	0	0	1	62.4 μs + 0.5/f _{sck}	65.6 μs + 1.5/f _{sck}
0	0	0	1	0	88.0 μs + 0.5/f _{sck}	91.2 μs + 1.5/f _{sck}
0	0	0	1	1	113.6 μs + 0.5/f _{sck}	116.8 μs + 1.5/f _{sck}
0	0	1	0	0	139.2 μs + 0.5/f _{sck}	142.4 μs + 1.5/f _{sck}
0	0	1	0	1	164.8 μs + 0.5/f _{sck}	168.0 μs + 1.5/f _{sck}
0	0	1	1	0	190.4 μs + 0.5/f _{sck}	193.6 μs + 1.5/f _{sck}
0	0	1	1	1	216.0 μs + 0.5/f _{sck}	219.2 μs + 1.5/f _{sck}
0	1	0	0	0	241.6 μs + 0.5/f _{sck}	244.8 μs + 1.5/f _{sck}
0	1	0	0	1	267.2 μs + 0.5/f _{sck}	270.4 μs + 1.5/f _{sck}
0	1	0	1	0	292.8 μs + 0.5/f _{sck}	296.0 μs + 1.5/f _{sck}
0	1	0	1	1	318.4 μs + 0.5/f _{sck}	321.6 μs + 1.5/f _{sck}
0	1	1	0	0	344.0 μs + 0.5/f _{sck}	347.2 μs + 1.5/f _{sck}
0	1	1	0	1	369.6 μs + 0.5/f _{sck}	372.8 μs + 1.5/f _{sck}
0	1	1	1	0	395.2 μs + 0.5/f _{sck}	398.4 μs + 1.5/f _{sck}
0	1	1	1	1	420.8 μs + 0.5/f _{sck}	424.0 μs + 1.5/f _{sck}

- Notes**
- The interval is dependent only on CPU processing.
 - The data transfer interval includes an error. The data transfer minimum and maximum intervals are found from the following expressions (n: Value set in ADTI0 to ADTI4). However, if a minimum which is calculated by the following expressions is smaller than 2/f_{sck}, the minimum interval time is 2/f_{sck}.

$$\text{Minimum} = (n+1) \times \frac{2^6}{f_{xx}} + \frac{28}{f_{xx}} + \frac{0.5}{f_{sck}}$$

$$\text{Maximum} = (n+1) \times \frac{2^6}{f_{xx}} + \frac{36}{f_{xx}} + \frac{1.5}{f_{sck}}$$

- Cautions**
- Do not write data to ADTI during operation of automatic data transmit/receive function.
 - Bits 5 and 6 must be set to zero.
 - To control the data transfer interval by means of automatic transmission/reception with ADTI, busy control (refer to 18.4.3 (4) (a) Busy control option) is disabled.

- Remarks**
- f_{xx} : Main system clock frequency (f_x or f_x/2)
 - f_x : Main system clock oscillation frequency
 - f_{sck} : Serial clock frequency

Symbol	7	6	5	4	3	2	1	0	Address	After Reset	R/W
ADTI	ADTI7	0	0	ADTI4	ADTI3	ADTI2	ADTI1	ADTI0	FF6BH	00H	R/W

ADTI4	ADTI3	ADTI2	ADTI1	ADTI0	Data Transfer Interval Specification (f _{xx} = 2.5 MHz Operation)	
					Minimum ^{Note}	Maximum ^{Note}
1	0	0	0	0	446.4 μs + 0.5/f _{sck}	449.6 μs + 1.5/f _{sck}
1	0	0	0	1	472.0 μs + 0.5/f _{sck}	475.2 μs + 1.5/f _{sck}
1	0	0	1	0	497.6 μs + 0.5/f _{sck}	500.8 μs + 1.5/f _{sck}
1	0	0	1	1	523.2 μs + 0.5/f _{sck}	526.4 μs + 1.5/f _{sck}
1	0	1	0	0	548.8 μs + 0.5/f _{sck}	552.0 μs + 1.5/f _{sck}
1	0	1	0	1	574.4 μs + 0.5/f _{sck}	577.6 μs + 1.5/f _{sck}
1	0	1	1	0	600.0 μs + 0.5/f _{sck}	603.2 μs + 1.5/f _{sck}
1	0	1	1	1	625.6 μs + 0.5/f _{sck}	628.8 μs + 1.5/f _{sck}
1	1	0	0	0	651.2 μs + 0.5/f _{sck}	654.4 μs + 1.5/f _{sck}
1	1	0	0	1	676.8 μs + 0.5/f _{sck}	680.0 μs + 1.5/f _{sck}
1	1	0	1	0	702.4 μs + 0.5/f _{sck}	705.6 μs + 1.5/f _{sck}
1	1	0	1	1	728.0 μs + 0.5/f _{sck}	731.2 μs + 1.5/f _{sck}
1	1	1	0	0	753.6 μs + 0.5/f _{sck}	756.8 μs + 1.5/f _{sck}
1	1	1	0	1	779.2 μs + 0.5/f _{sck}	782.4 μs + 1.5/f _{sck}
1	1	1	1	0	804.8 μs + 0.5/f _{sck}	808.0 μs + 1.5/f _{sck}
1	1	1	1	1	830.4 μs + 0.5/f _{sck}	833.6 μs + 1.5/f _{sck}

Note The data transfer interval includes an error. The data transfer minimum and maximum intervals are found from the following expressions (n: Value set in ADTI0 to ADTI4). However, if a minimum which is calculated by the following expressions is smaller than 2/f_{sck}, the minimum interval time is 2/f_{sck}.

$$\text{Minimum} = (n+1) \times \frac{2^6}{f_{xx}} + \frac{28}{f_{xx}} + \frac{0.5}{f_{sck}}$$

$$\text{Maximum} = (n+1) \times \frac{2^6}{f_{xx}} + \frac{36}{f_{xx}} + \frac{1.5}{f_{sck}}$$

- Cautions**
1. Do not write data to ADTI during operation of automatic data transmit/receive function.
 2. Bits 5 and 6 must be set to zero.
 3. To control the data transfer interval by means of automatic transmission/reception with ADTI, busy control (refer to 18.4.3 (4) (a) Busy control option) is disabled.

- Remarks**
1. f_{xx} : Main system clock frequency (fx or fx/2)
 2. fx : Main system clock oscillation frequency
 3. f_{sck} : Serial clock frequency

(2) Automatic transmit/receive data setting**(a) Transmit data setting**

- <1> Write transmit data from the least significant address FAC0H of buffer RAM (up to FADFH at maximum). The transmit data should be in the order from high-order address to low-order address.
- <2> Set to the automatic data transmit/receive address pointer (ADTP) the value obtained by subtracting 1 from the number of transmit data bytes.

(b) Automatic transmit/receive mode setting

- <1> Set bit 7 (CSIE1) to 1 and bit 5 (ATE) to 1 of the serial operating mode register 1 (CSIM1) to 1.
- <2> Set bit 7 (RE) of the automatic data transmit/receive control register (ADTC) to 1.
- <3> Set a data transmit/receive interval in the automatic data transmit/receive interval specify register (ADTI).
- <4> Write any value to the serial I/O shift register 1 (SIO1) (transfer start trigger).

Caution Writing any value to SIO1 orders the start of automatic transmit/receive operation and the written value has no meaning.

The following operations are automatically carried out when (a) and (b) are carried out.

- After the buffer RAM data specified with ADTP is transferred to SIO1, transmission is carried out (start of automatic transmission/reception).
- The received data is written to the buffer RAM address specified with ADTP.
- ADTP is decremented and the next data transmission/reception is carried out. Data transmission/reception continues until the ADTP decremental output becomes 00H and address FAC0H data is output (end of automatic transmission/reception).
- When automatic transmission/reception is terminated, bit 3 (TRF) of ADTC is cleared to 0.

(3) Communication operation**(a) Basic transmission/reception mode**

This transmission/reception mode is the same as the 3-wire serial I/O mode in which specified number of data are transmitted/received in 8-bit units.

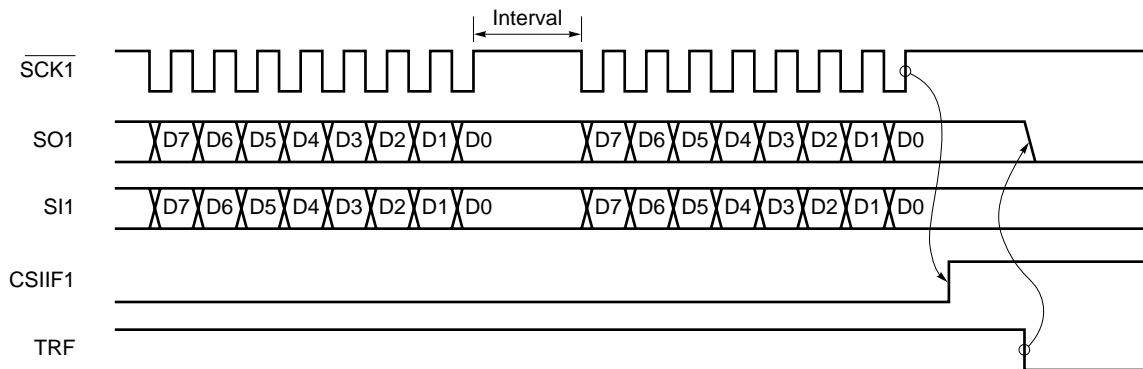
Serial transfer is started when any data is written to the serial I/O shift register 1 (SIO1) while bit 7 (CSIE1) of the serial operating mode register 1 (CSIM1) is set to 1.

The interrupt request flag (CSIF1) is set upon completion of transmission of the last byte. However, judge the completion of the automatic transmission/reception not with CSIF1 but bit 3 (TRF) of the automatic data transmit/receive control register (ADTC).

If busy control and strobe control are not executed, the P23/STB and P24/BUSY pins can be used as normal input/output ports.

Figure 18-8 shows the basic transmission/reception mode operation timings, and Figure 18-9 shows the operation flowchart. Figure 18-10 shows the operation of the buffer RAM when 6 bytes of data are transmitted or received.

Figure 18-8. Basic Transmission/Reception Mode Operation Timings



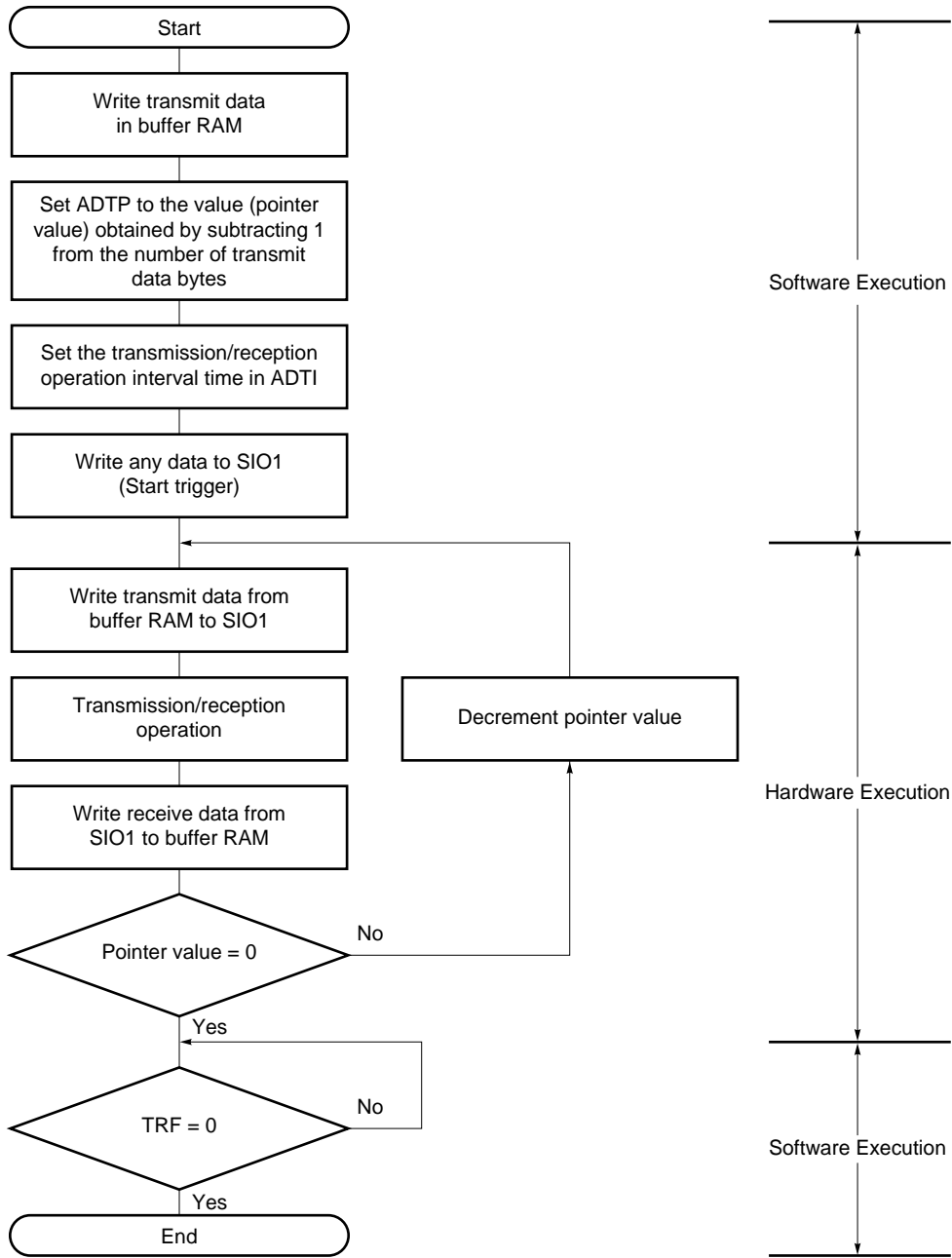
Cautions 1. Because, in the basic transmission/reception mode, the automatic transmit/receive function writes/reads data to/from the buffer RAM after 1-byte transmission/reception, an interval is inserted till the next transmission/reception. As the buffer RAM write/read is performed at the same time as CPU processing, the maximum interval is dependent upon CPU processing and the value of the automatic data transmit/receive interval specify register (ADTI) (see (5) "Automatic data transmit/receive interval").

2. When TRF is cleared, the SO1 pin becomes low level.

Remark CSIF1 : Interrupt request flag

TRF : Bit 3 of automatic data transmit/receive control register (ADTC)

Figure 18-9. Basic Transmission/Reception Mode Flowchart



ADTP : Automatic data transmit/receive address pointer
 ADTI : Automatic data transmit/receive interval specify register
 SIO1 : Serial I/O shift register 1
 TRF : Bit 3 of automatic data transmit/receive control register (ADTC)

In 6-byte transmission/reception (ARLD=0, RE=1) in basic transmit/receive mode, buffer RAM operates as follows.

(i) Before transmission/reception (Refer to Figure 18-10 (a))

After any data has been written to serial I/O shift register 1 (SIO1) (start trigger: this data is not transferred), transmit data 1 (T1) is transferred from the buffer RAM to SIO1. When transmission of the first byte is completed, the receive data 1 (R1) is transferred from SIO1 to the buffer RAM, and automatic data transmit/receive address pointer (ADTP) is decremented. Then transmit data 2 (T2) is transferred from the buffer RAM to SIO1.

(ii) 4th byte transmission/reception point (Refer to Figure 18-10 (b))

Transmission/reception of the third byte is completed, and transmit data 4 (T4) is transferred from the buffer RAM to SIO1. When transmission of the fourth byte is completed, the receive data 4 (R4) is transferred from SIO1 to the buffer RAM, and ADTP is decremented.

(iii) Completion of transmission/reception (Refer to Figure 18-10 (c))

When transmission of the sixth byte is completed, the receive data 6 (R6) is transferred from SIO1 to the buffer RAM, and the interrupt request flag (CSIF1) is set (INTCSI1 generation).

Figure 18-10. Buffer RAM Operation in 6-Byte Transmission/Reception (in Basic Transmit/Receive Mode) (1/2)

(a) Before transmission/reception

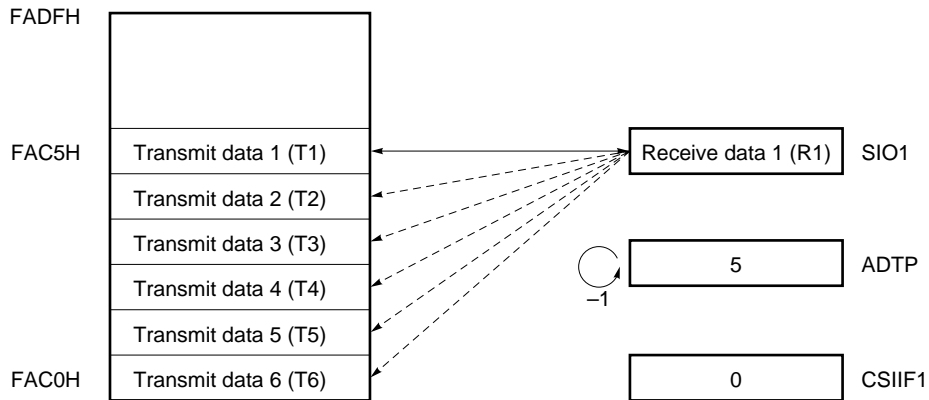
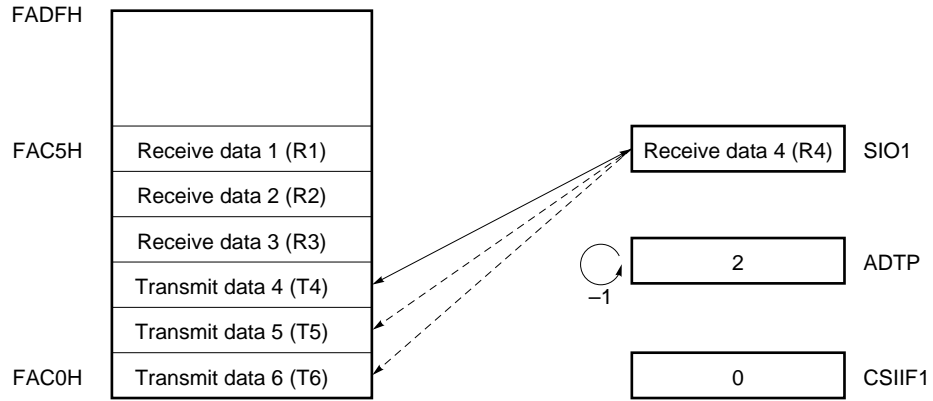
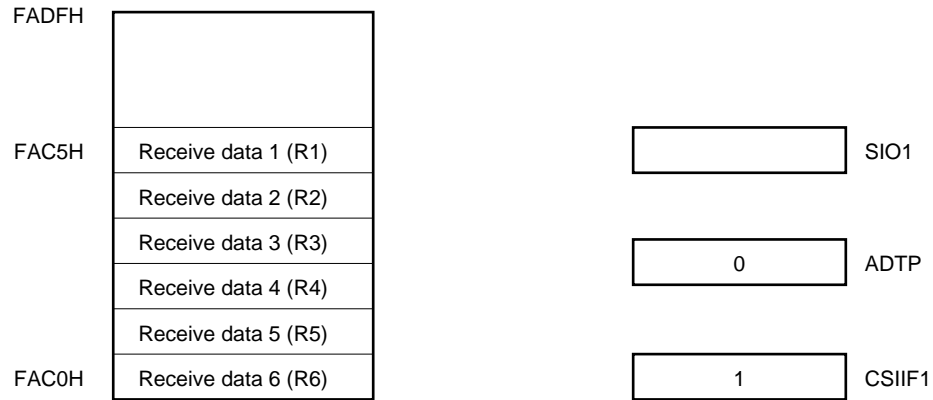


Figure 18-10. Buffer RAM Operation in 6-Byte Transmission/Reception (in Basic Transmit/Receive Mode) (2/2)

(b) 4th byte transmission/reception



(c) Completion of transmission/reception



(b) Basic transmission mode

In this mode, the specified number of 8-bit unit data are transmitted.

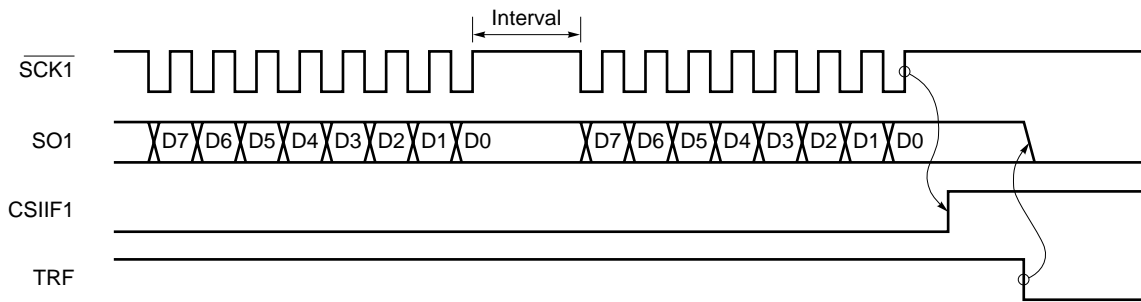
Serial transfer is started when any data is written to the serial I/O shift register 1 (SIO1) while bit 7 (CSIE1) of the serial operating mode register 1 (CSIM1) is set to 1.

The interrupt request flag (CSIIF1) is set upon completion of transmission of the last byte. However, judge the completion of the automatic transmission/reception not with CSIIF1 but bit 3 (TRF) of the automatic data transmit/receive control register (ADTC).

If receive operation, busy control and strobe control are not executed, the P20/SI1, P23/STB and P24/BUSY pins can be used as normal input/ports.

Figure 18-11 shows the basic transmission mode operation timings, and Figure 18-12 shows the operation flowchart. Figure 18-13 shows the operation of the buffer RAM when 6 bytes of data are transmitted or received.

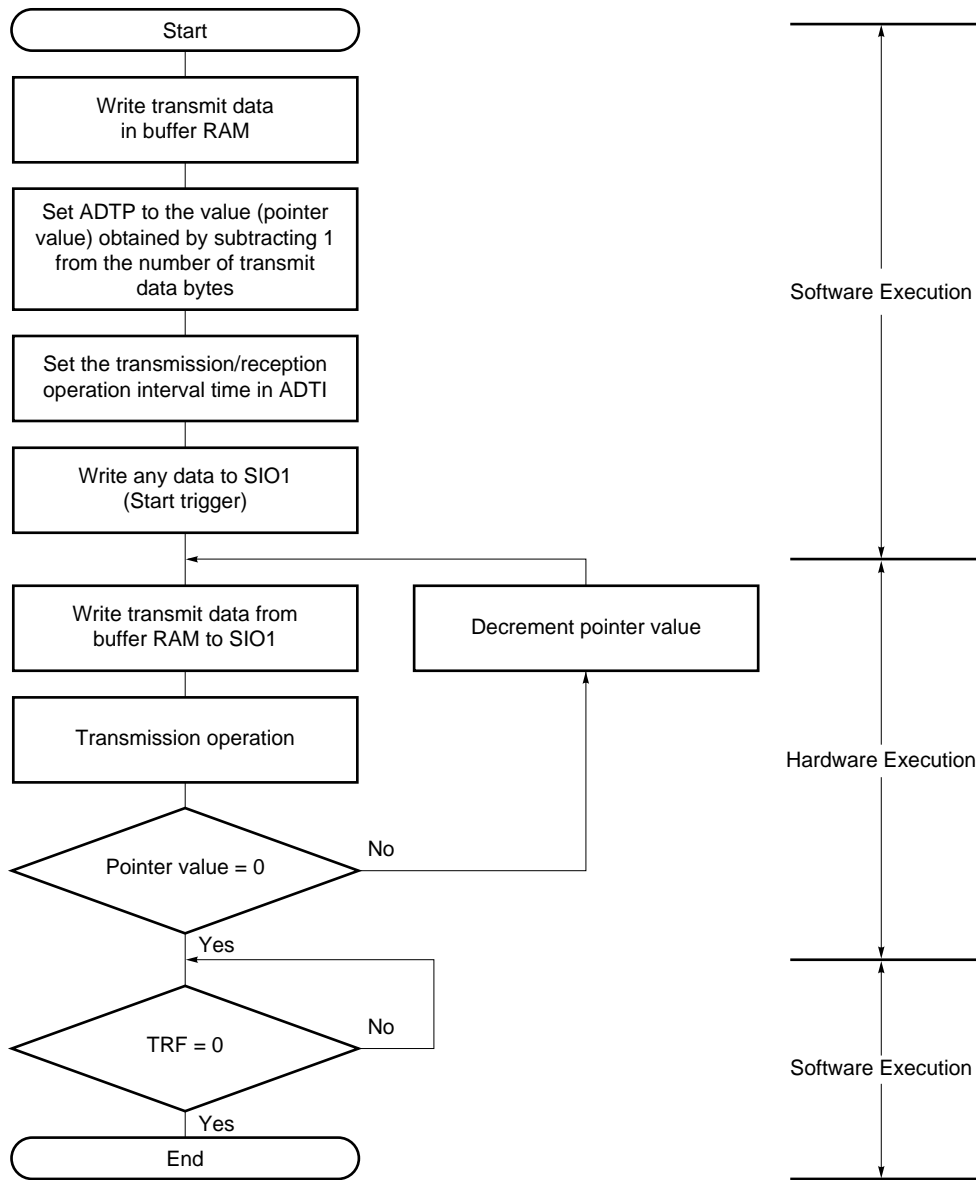
Figure 18-11. Basic Transmission Mode Operation Timings



- Cautions**
1. Because, in the basic transmission mode, the automatic transmit/receive function reads data from the buffer RAM after 1-byte transmission, an interval is inserted till the next transmission. As the buffer RAM read is performed at the same time as CPU processing, the maximum interval is dependent upon CPU processing and the value of the automatic data transmit/receive interval specify register (ADTI) (see (5) "Automatic data transmit/receive interval").
 2. When TRF is cleared, the SO1 pin becomes low level.

Remark CSIIF1 : Interrupt request flag
 TRF : Bit 3 of automatic data transmit/receive control register (ADTC)

Figure 18-12. Basic Transmission Mode Flowchart



- ADTP : Automatic data transmit/receive address pointer
- ADTI : Automatic data transmit/receive interval specify register
- SIO1 : Serial I/O shift register 1
- TRF : Bit 3 of automatic data transmit/receive control register (ADTC)

In 6-byte transmission (ARLD=0, RE=0) in basic transmit mode, buffer RAM operates as follows.

(i) Before transmission (Refer to Figure 18-13 (a))

After any data has been written to serial I/O shift register 1 (SIO1) (start trigger: this data is not transferred), transmit data 1 (T1) is transferred from the buffer RAM to SIO1. When transmission of the first byte is completed, automatic data transmit/receive address pointer (ADTP) is decremented. Then transmit data 2 (T2) is transferred from the buffer RAM to SIO1.

(ii) 4th byte transmission point (Refer to Figure 18-13 (b))

Transmission of the third byte is completed, and transmit data 4 (T4) is transferred from the buffer RAM to SIO1. When transmission of the fourth byte is completed, ADTP is decremented.

(iii) Completion of transmission (Refer to Figure 18-13 (c))

When transmission of the sixth byte is completed, the interrupt request flag (CSIF1) is set (INTCSI1 generation).

Figure 18-13. Buffer RAM Operation in 6-Byte Transmission (in Basic Transmit Mode) (1/2)

(a) Before transmission

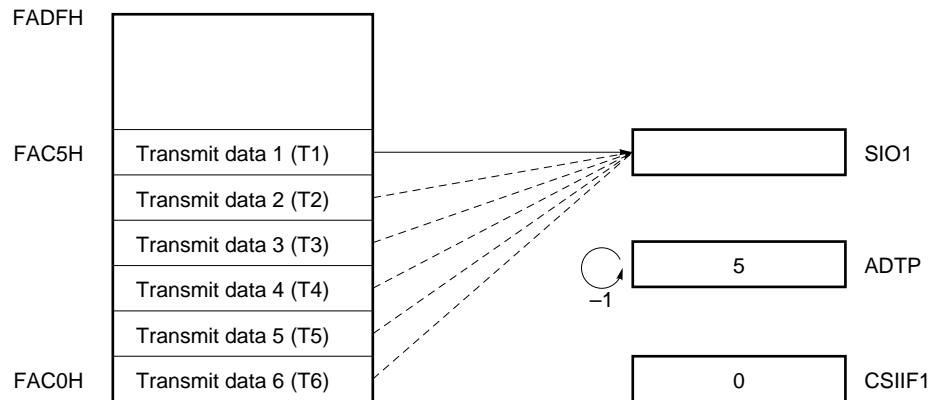
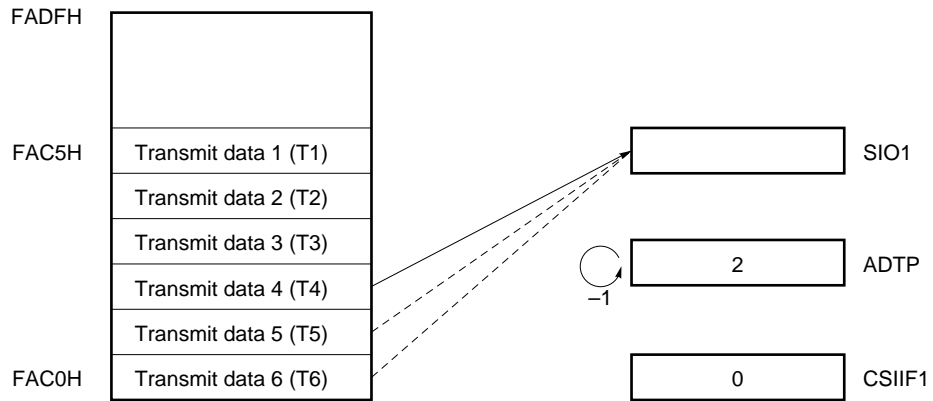
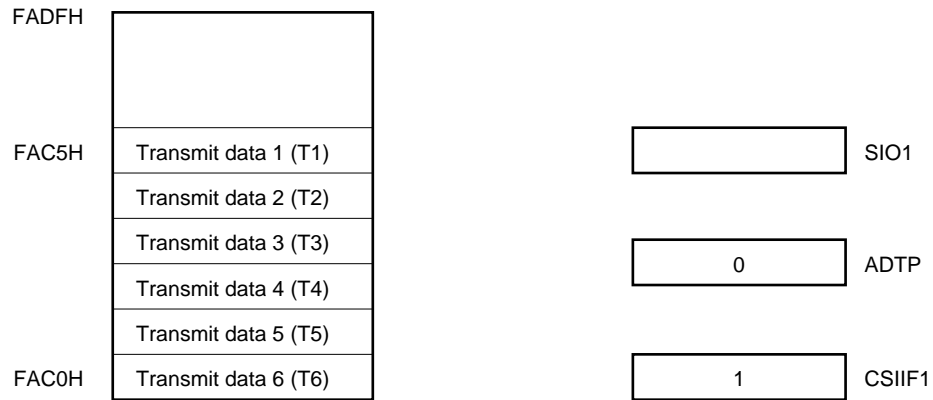


Figure 18-13. Buffer RAM Operation in 6-Byte Transmission (in Basic Transmit Mode) (2/2)

(b) 4th byte transmission point



(c) Completion of transmission



(c) Repeat transmission mode

In this mode, data stored in the buffer RAM is transmitted repeatedly.

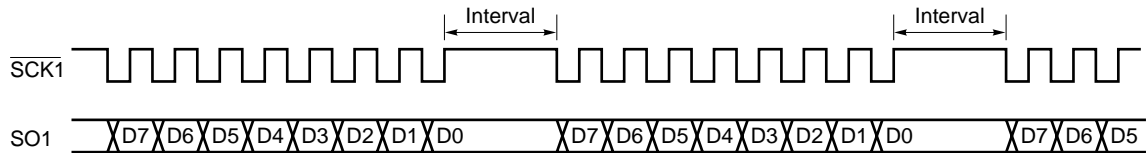
Serial transfer is started by writing any data to serial I/O shift register 1 (SIO1) when 1 is set in bit 7 (CSIE1) of the serial operating mode register 1 (CSIM1).

Unlike the basic transmission mode, after the last byte (data in address FAC0H) has been transmitted, the interrupt request flag (CSIF1) is not set, the value at the time when the transmission was started is set in the automatic data transmit/receive address pointer (ADTP) again, and the buffer RAM contents are transmitted again.

When a reception operation, busy control and strobe control are not performed, the P20/SI1, P23/STB and P24/BUSY pins can be used as ordinary input/output ports.

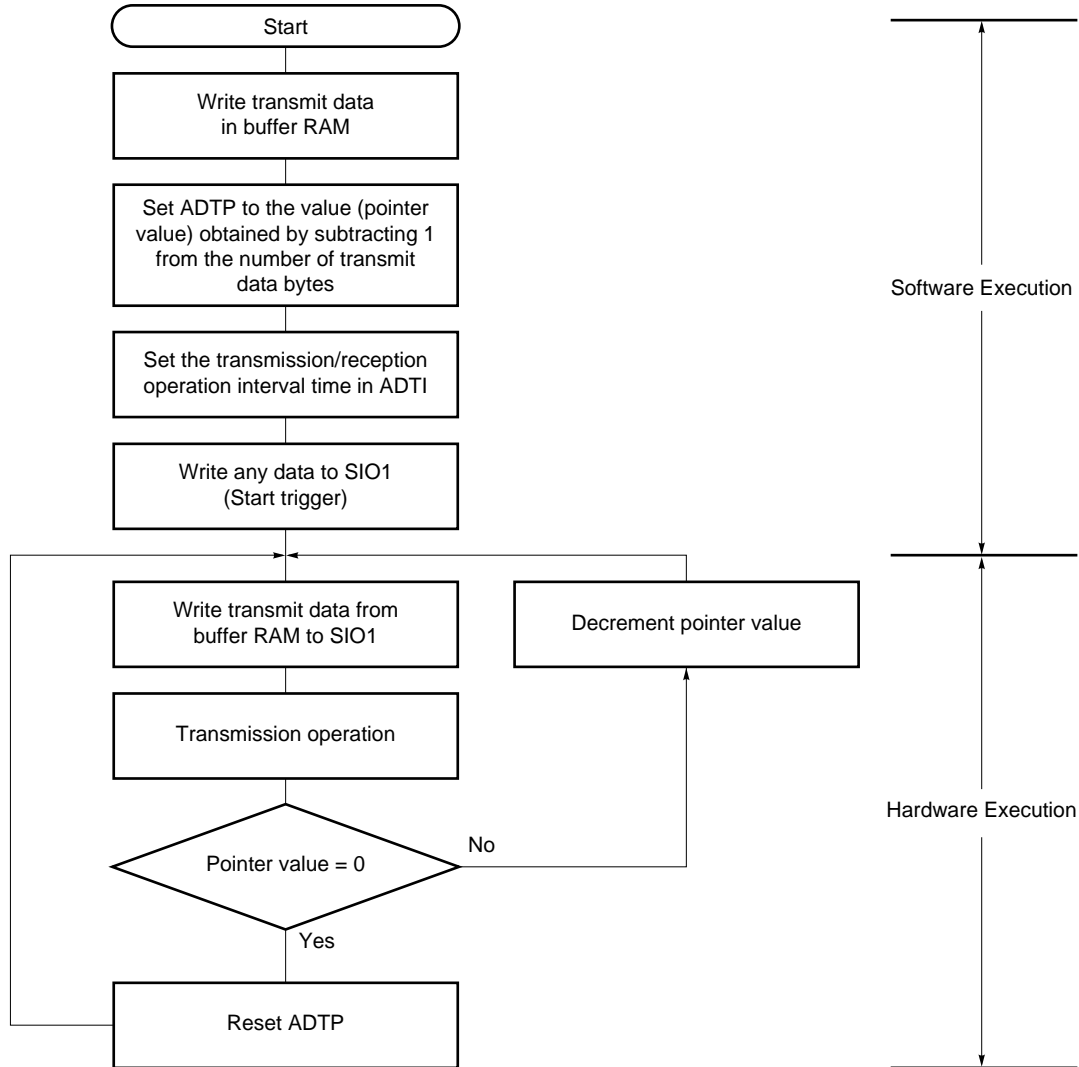
The repeat transmission mode operation timing is shown in Figure 18-14, and the operation flowchart in Figure 18-15. Figure 18-16 shows the operation of the buffer RAM when 6 bytes of data are transmitted in the repeat transmission mode.

Figure 18-14. Repeat Transmission Mode Operation Timing



Caution Since, in the repeat transmission mode, a read is performed on the buffer RAM after the transmission of one byte, the interval is included in the period up to the next transmission. As the buffer RAM read is performed at the same time as CPU processing, the maximum interval is dependent upon the CPU operation and the value of the automatic data transmit/receive interval specify register (ADTI) (see (5) "Automatic data transmit/receive interval").

Figure 18-15. Repeat Transmission Mode Flowchart



ADTP : Automatic data transmit/receive address pointer
 ADTI : Automatic data transmit/receive interval specify register
 SIO1 : Serial I/O shift register 1

In 6-byte transmission (ARLD=1, RE=0) in repeat transmit mode, buffer RAM operates as follows.

(i) Before transmission (Refer to Figure 18-16 (a))

After any data has been written to serial I/O shift register 1 (SIO1) (start trigger: this data is not transferred), transmit data 1 (T1) is transferred from the buffer RAM to SIO1. When transmission of the first byte is completed, automatic data transmit/receive address pointer (ADTP) is decremented. Then transmit data 2 (T2) is transferred from the buffer RAM to SIO1.

(ii) Upon completion of transmission of 6 bytes (Refer to Figure 18-16 (b))

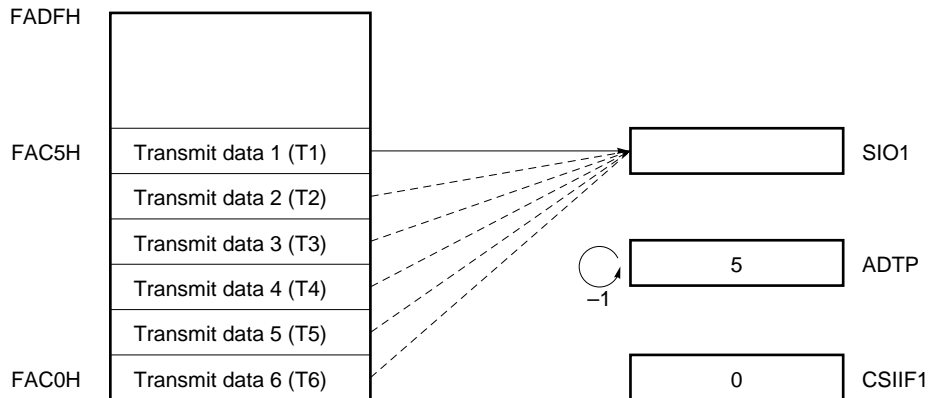
When transmission of the sixth byte is completed, the interrupt request flag (CSIF1) is not set. The first pointer value is set to ADTP again.

(iii) 7th byte transmission point (Refer to Figure 18-16 (c))

Transmit data 1 (T1) is transferred from the buffer RAM to SIO1 again. When transmission of the first byte is completed, ADTP is decremented. Then transmit data 2 (T2) is transferred from the buffer RAM to SIO1.

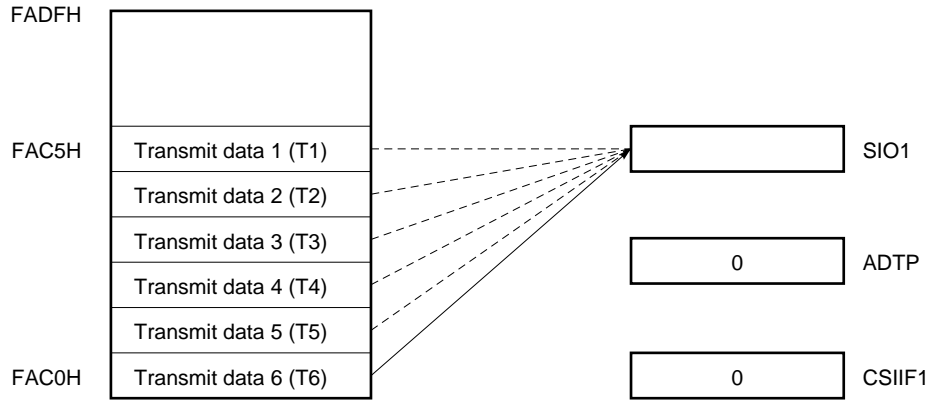
Figure 18-16. Buffer RAM Operation in 6-Byte Transmission (in Repeat Transmit Mode) (1/2)

(a) Before transmission

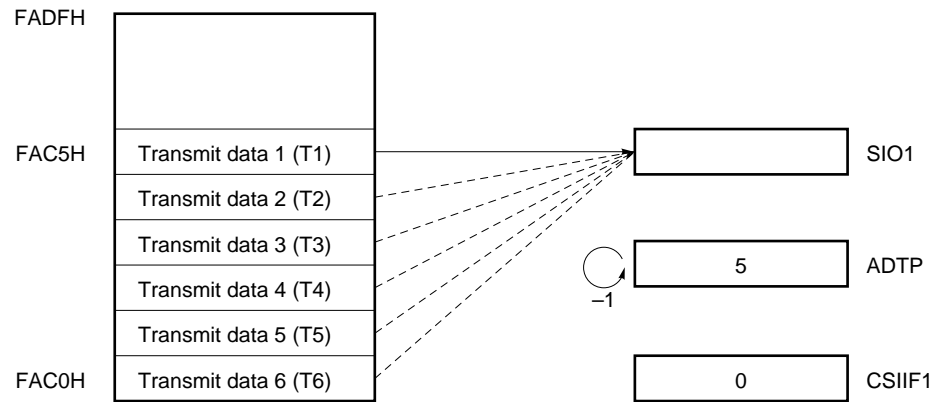


**Figure 18-16. Buffer RAM Operation in 6-Byte Transmission
(in Repeat Transmit Mode) (2/2)**

(b) Upon completion of transmission of 6 bytes



(c) 7th byte transmission point



(d) Automatic transmission/reception suspending and restart

Automatic transmission/reception can be temporarily suspended by setting bit 7 (CSIE1) of the serial operating mode register 1 (CSIM1) to 0.

If during 8-bit data transfer, the transmission/reception is not suspended if bit 7 (CSIE1) is set to 0. It is suspended upon completion of 8-bit data transfer.

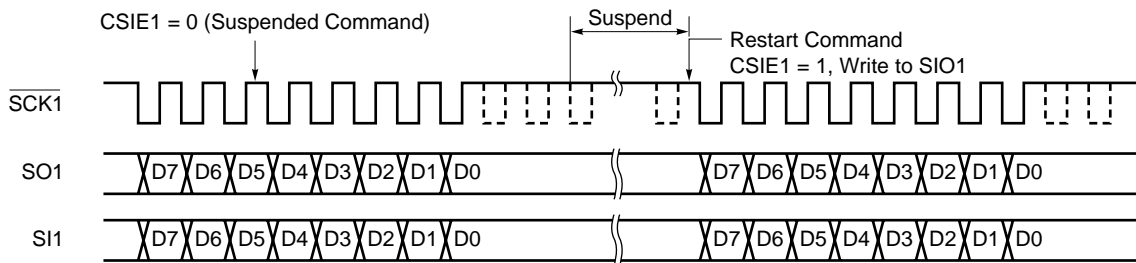
When suspended, bit 3 (TRF) of the automatic data transmit/receive control register (ADTC) is set to 0 after transfer of the 8th bit, and all the port pins used with the serial interface pins for dual function (P20/SI1, P21/SO1, P22/SCK1, P23/STB and P24/BUSY) are set to the port mode.

During restart of transmission/reception, remaining data can be transferred by setting CSIE1 to 1 and writing any data to the serial I/O shift register 1 (SIO1).

Cautions 1. If the HALT instruction is executed during automatic transmission/reception, transfer is suspended and the HALT mode is set if during 8-bit data transfer. When the HALT mode is cleared, automatic transmission/reception is restarted from the suspended point.

2. When suspending automatic transmission/reception, do not change the operating mode to 3-wire serial I/O mode while TRF = 1.

Figure 18-17. Automatic Transmission/Reception Suspension and Restart



Remark CSIE1 : Bit 7 of serial operating mode register 1 (CSIM1)

★ (4) Synchronization Control

Busy control and strobe control are functions for synchronizing sending and receiving between the master device and slave device.

By using these functions, it is possible to detect bit slippage during sending and receiving.

(a) Busy control Option

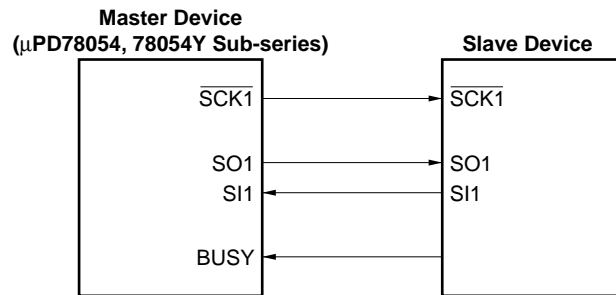
Busy control is a function which causes the master device's serial transmission to wait when the slave device outputs a busy signal to the master device, and maintain the wait state while that busy signal is active.

When the busy control option is used, the conditions shown below are necessary.

- Bit 5 (ATE) of serial operation mode register 1 (CSIM1) should be set at (1).
- Bit 1 (BUSY1) of the auto data send and receive control register (ADTC) should be set at (1).

The system configuration between the master device and slave device in cases where the busy control option is used is shown in Figure 18-18.

Figure 18-18. System Configuration When the Busy Control Option is Used



The master device inputs the busy signal output by the slave device to pin BUSY/P24. In sync with the fall of the serial clock, the master device samples the input busy signal. Even if the busy signal becomes active during sending or receiving of 8 bit data, the wait does not apply. If the busy signal becomes active at the rise of the serial clock 2 clock cycles after sending or receiving of 8 bit data ends, the busy input first becomes effective at that point, and thereafter, sending or receiving of data waits during the period that the busy signal is active.

The busy signal's active level is set in bit 0 (BUSY0) of ADTC.

BUSY0 = 0: Active High

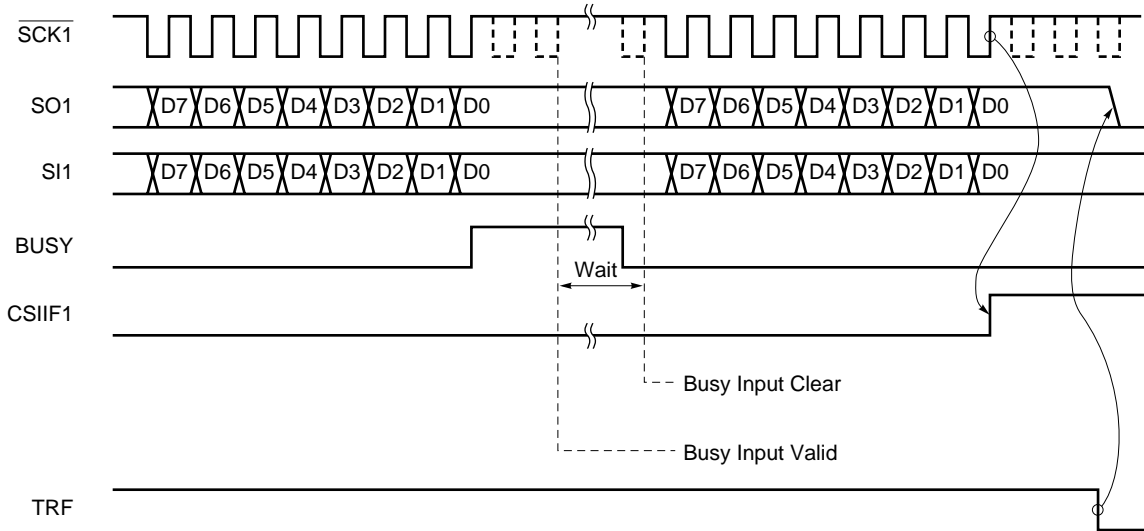
BUSY0 = 1: Active Low

Furthermore, in the case that the busy control option is used, select the internal clock for the serial clock. The busy signal cannot be controlled with an external clock.

The operation timing when the busy control option is used is shown in Figure 18-19.

Caution Busy control cannot be used at the same time as interval timing control using the auto data send and receive interval instruction register (ADTI). If both are used simultaneously, busy control becomes invalid.

Figure 18-19. Operation Timings when Using Busy Control Option (BUSY0 = 0)



Caution When TRF is cleared, the SO1 pin becomes low level.

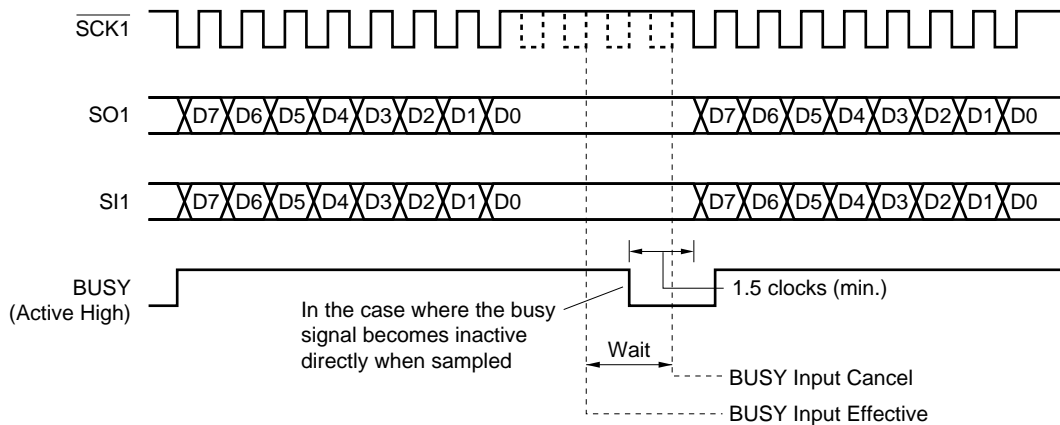
Remark CSIIF1: Interrupt request flag
 TRF : Bit 3 of the auto data send and receive control register (ADTC)

If the busy signal becomes inactive, the wait is canceled. If the sampled busy signal is inactive, sending or receiving of the next 8 bit data begins from the fall of the next serial clock cycle. Furthermore, the busy signal is asynchronous with the serial clock, so even if the slave side inactivates the busy signal, it takes nearly 1 clock cycle at the most until it is sampled again. Also, it takes another 0.5 clock cycle after sampling until data transmission resumes.

Therefore, in order to definitely cancel a wait state, it is necessary for the slave side to keep the busy signal for at least 1.5 clock cycles.

Figure 18-20 shows the timing of the busy signal and wait cancel. In this figure, an example of the case where the busy signal becomes active when sending or receiving starts is shown.

Figure 18-20. Busy Signal and Wait Cancel (when BUSY0 = 0)



(b) Busy & strobe control option

Strobe control is a function for synchronizing the sending and receiving of data between a master device and slave device. When sending or receiving of 8 bit data ends, the strobe signal is output by the master device from pin STB/P23. Through this means, the slave device can know the timing of the end of master data transmission. Therefore, even if there is noise in the serial clock and bit slippage occurs, synchronization is maintained and bit slippage has no effect on transmission of the next byte. In the case that the strobe control option is used, the conditions shown below are necessary.

- Set bit 5 (ATE) of serial operation mode register 1 (CSIM1) at (1).
- Set bit 2 (STRB) of the auto data send and receive control register (ADTC) at (1).

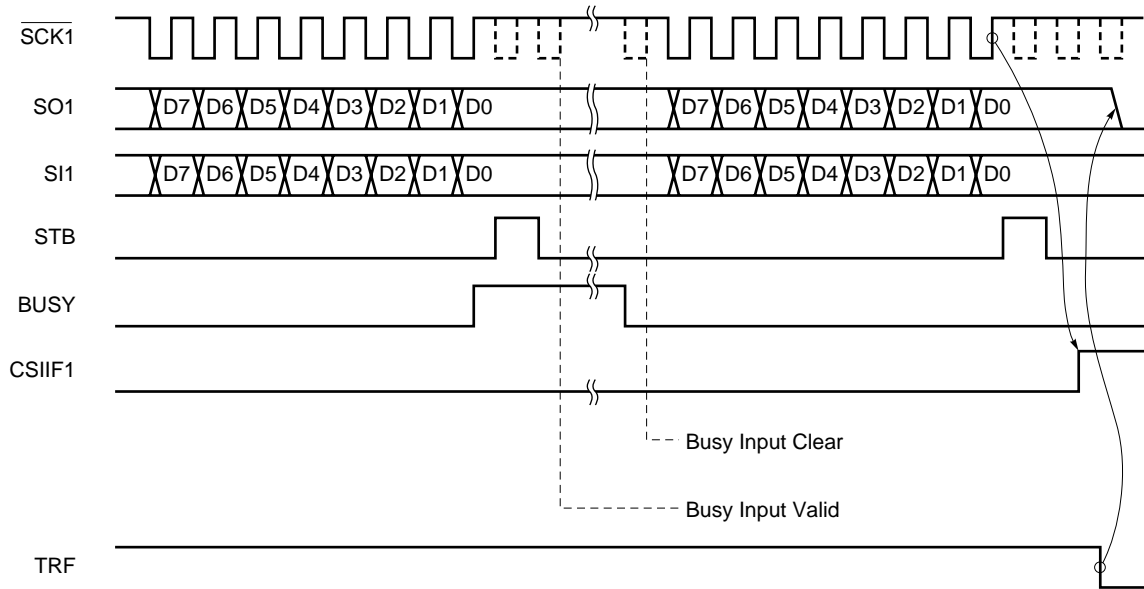
Normally, busy control and strobe control are used simultaneously as handshake signals. In this case, together with output of the strobe signal from pin STB/P23, pin BUSY/P24 can be sampled and sending or receiving can wait while the busy signal is being input.

If strobe control is not carried out, pin P23/STB can be used as a normal I/O port.

Operation timing when busy and strobe control are used is shown in Figure 18-21.

Furthermore, if strobe control is used, the interrupt request flag (CSIF1), set when sending or receiving ends, is set after the strobe signal is output.

Figure 18-21. Operation Timings when Using Busy & Strobe Control Option (BUSY0 = 0)



Caution When TRF is cleared, the SO1 pin becomes low level.

Remarks CSIF1: Interrupt request flag

TRF : Bit 3 of the auto data send and receive control register (ADTC)

(c) Bit Slippage Detection Function Through the Busy Signal

During an auto send and receive operation, noise occur in the serial clock signal output by the master device and bit slippage may occur in the slave device side serial clock. At this time, if the strobe control option is not used, this bit slippage will have an effect on sending of the next byte. In such a case, the busy control option can be used on the master device side and, by checking the busy signal during sending, bit slippage can be detected.

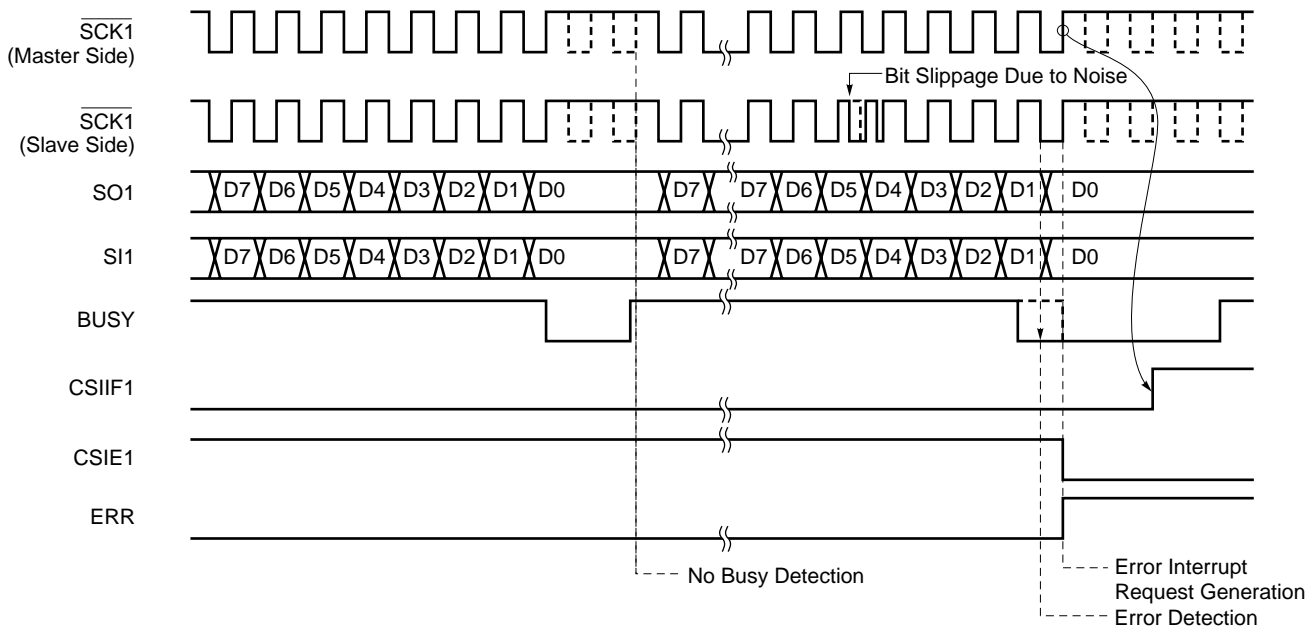
Bit slippage detection through the busy signal is accomplished as follows.

The slave side outputs a busy signal after the serial clock rises on the 8th cycle of data sending or receiving (at this time, if application of the wait state by the busy signal is not desired, the busy signal is made inactive within 2 clock cycles).

The master device side samples the busy signal in sync with the fall of the serial clock's front side. If no bit slippage is occurring, the busy signal will be inactive in sampling for 8 clock cycles. If the busy signal is found to be active in sampling, it is regarded as an occurrence of bit slippage error processing is executed (bit 4 (ERR) of the auto data send and receive control register (ADTC) is set at (1)).

The operation timing of the bit slippage detection function through the busy signal is shown in Figure 18-22.

Figure 18-22. Operation Timing of the Bit Slippage Detection Function Through the Busy Signal (when BUSY0 = 1)



- Remark** CSIF1 : Interrupt Request Flag
- CSIE1 : Bit 7 of serial operation mode register 1 (CSIM1)
- ERR : Bit 4 of the auto data send and receive control register (ADTC)

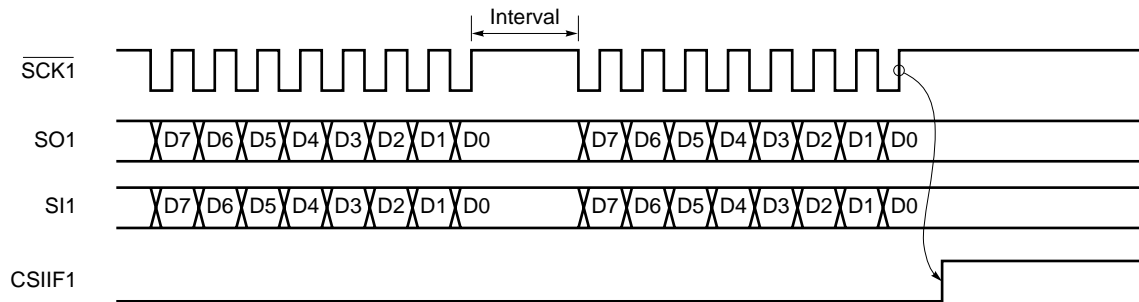
★ (5) Automatic transmit/receive interval time

When using the automatic transmit/receive function, the read/write operations from/to the buffer RAM are performed after transmitting/receiving one byte. Therefore, an interval is inserted before the next transmit/receive.

Since the read/write operations from/to the buffer RAM are performed in parallel with the CPU processing when using the automatic transmit/receive function by the internal clock, the interval depends on the value which is set in the automatic transmit/receive interval specification register (ADTI) and the CPU processing at the rising edge of the eighth serial clock. Whether it depends on the ADTI or not can be selected by the setting of its bit 7 (ADTI7). When it is set to 0, the interval depends only on the CPU processing. When it is set to 1, the interval depends on the contents of the ADTI or CPU processing, whichever is greater.

When the automatic transmit/receive function is used by an external clock, it must be selected so that the interval may be longer than the value indicated by paragraph (b).

Figure 18-23. Automatic Data Transmit/Receive Interval



Remark CSIF1: Interrupt request flag

(a) When the automatic transmit/receive function is used by the internal clock

If bit 1 (CSIM11) of serial operation mode register 1 (CSIM1) is set at (1), the internal clock operates. If the auto send and receive function is operated by the internal clock, interval timing by CPU processing is as follows.

When bit 7 (ADTI7) of automatic data transmit/receive interval specify register (ADTI) is set to 0, the interval depends on the CPU processing. When ADTI7 is set to 1, it depends on the contents of the ADTI or CPU processing, whichever is greater.

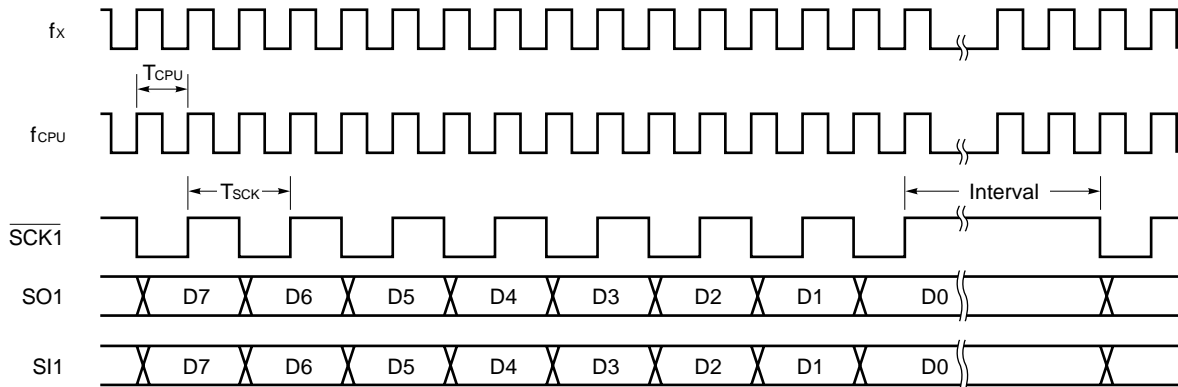
Refer to Figure 18-5, "Automatic Data Transmit/Receive Interval Specify Register Format" for the intervals which are set by the ADTI.

Table 18-2. Interval Timing Through CPU Processing (when the internal clock is operating)

CPU Processing	Interval Time
When using multiplication instruction	Max. (2.5T _{SCK} , 13T _{CPU})
When using division instruction	Max. (2.5T _{SCK} , 20T _{CPU})
External access 1 wait mode	Max. (2.5T _{SCK} , 9T _{CPU})
Other than above	Max. (2.5T _{SCK} , 7T _{CPU})

Remark T_{SCK} : 1/f_{sck}
 f_{sck} : Serial clock frequency
 T_{CPU} : 1/f_{cpu}
 f_{cpu} : CPU clock (set by bits 0 to 2 (PCC0 to PCC2) of the processor clock control register (PCC) and bit 0 (MCS) of the oscillation mode selection register (OSMS))
 MAX. (a, b) : a or b, whichever is greater

Figure 18-24. Operation Timing with Automatic Data Transmit/Receive Function Performed by Internal Clock



fx : Main system clock oscillation frequency
 f_{cpu} : CPU clock (set by bits 0 to 2 (PCC0 to PCC2) of the processor clock control register (PCC) and bit 0 (MCS) of the oscillation mode select register (OSMS)).
 T_{CPU} : 1/f_{cpu}
 T_{SCK} : 1/f_{sck}
 f_{sck} : Serial clock frequency

(b) When the automatic transmit/receive function is used by the external clock

If bit 1 (CSIM1) of serial operation mode register 1 (CSIM1) is cleared to 0, external clock operation is set.

When the automatic transmit/receive function is used by the external clock, it must be selected so that the interval may be longer than the values shown as follows.

Table 18-3. Interval Timing Through CPU Processing (when the external clock is operating)

CPU Processing	Interval Time
When using multiplication instruction	$13T_{\text{CPU}}$
When using division instruction	$20T_{\text{CPU}}$
External access 1 wait mode	$9T_{\text{CPU}}$
Other than above	$7T_{\text{CPU}}$

Remark T_{CPU} : $1/f_{\text{CPU}}$

f_{CPU} : CPU clock (set by the bits 0 to 2 (PCC0 to PCC2) of the processor clock control register (PCC) and bit 0 (MCS) of the oscillation mode selection register (OSMS))

[MEMO]

CHAPTER 19 SERIAL INTERFACE CHANNEL 2

19.1 Serial Interface Channel 2 Functions

Serial interface channel 2 has the following three modes.

- Operation stop mode
- Asynchronous serial interface (UART) mode
- 3-wire serial I/O mode

(1) Operation stop mode

This mode is used when serial transfer is not carried out to reduce power consumption.

(2) Asynchronous serial interface (UART) mode

In this mode, one byte of data is transmitted/received following the start bit, and full-duplex operation is possible.

A dedicated UART baud rate generator is incorporated, allowing communication over a wide range of baud rates. In addition, the baud rate can be defined also by scaling the input clock to the ASCK pin.

The MIDI standard baud rate (31.25 kbps) can also be used by employing the dedicated UART baud rate generator.

(3) 3-wire serial I/O mode (MSB-/LSB-first switchable)

In this mode, 8-bit data transfer is performed using three lines: the serial clock ($\overline{\text{SCK2}}$), and serial data lines (SI2, SO2).

In the 3-wire serial I/O mode, simultaneous transmission and reception is possible, increasing the data transfer processing speed.

Either the MSB or LSB can be specified as the start bit for an 8-bit data serial transfer, allowing connection to devices using either as the start bit.

The 3-wire serial I/O mode is useful for connection to peripheral I/Os and display controllers, etc., which incorporate a conventional synchronous clocked serial interface, such as the 75X/XL series, 78K series, 17K series, etc.

★ **Caution** In the 3-wire serial I/O mode of serial interface channel 2, only the output of the internal baud rate generator can be used for the operation clock. It is not possible to input a clock to pin $\overline{\text{SCK2}}$ from external.

19.2 Serial Interface Channel 2 Configuration

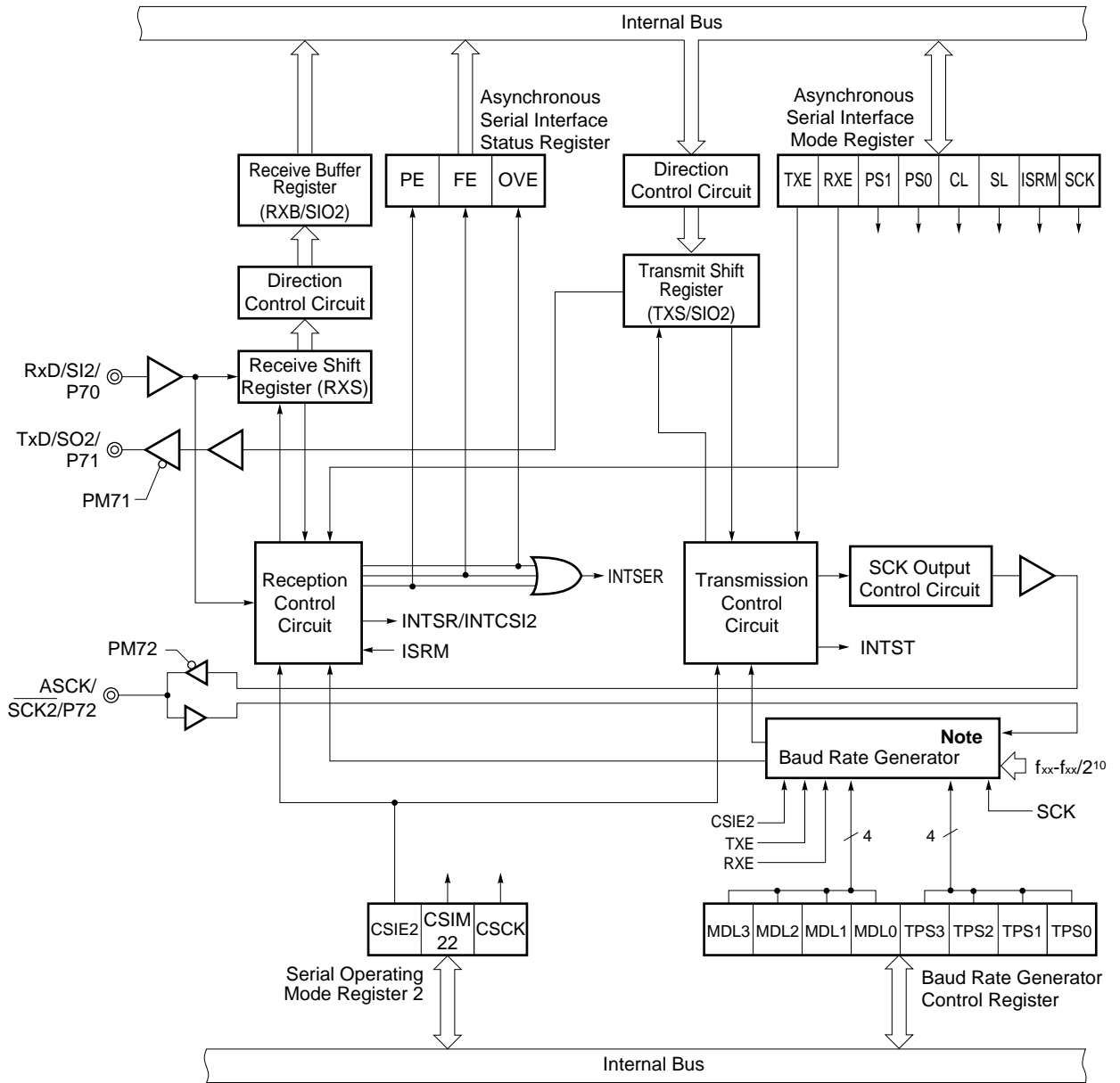
Serial interface channel 2 consists of the following hardware.

Table 19-1. Serial Interface Channel 2 Configuration

Item	Configuration
Register	Transmit shift register (TXS) Receive shift register (RXS) Receive buffer register (RXB)
Control register	Serial operating mode register 2 (CSIM2) Asynchronous serial interface mode register (ASIM) Asynchronous serial interface status register (ASIS) Baud rate generator control register (BRGC) ^{Note}

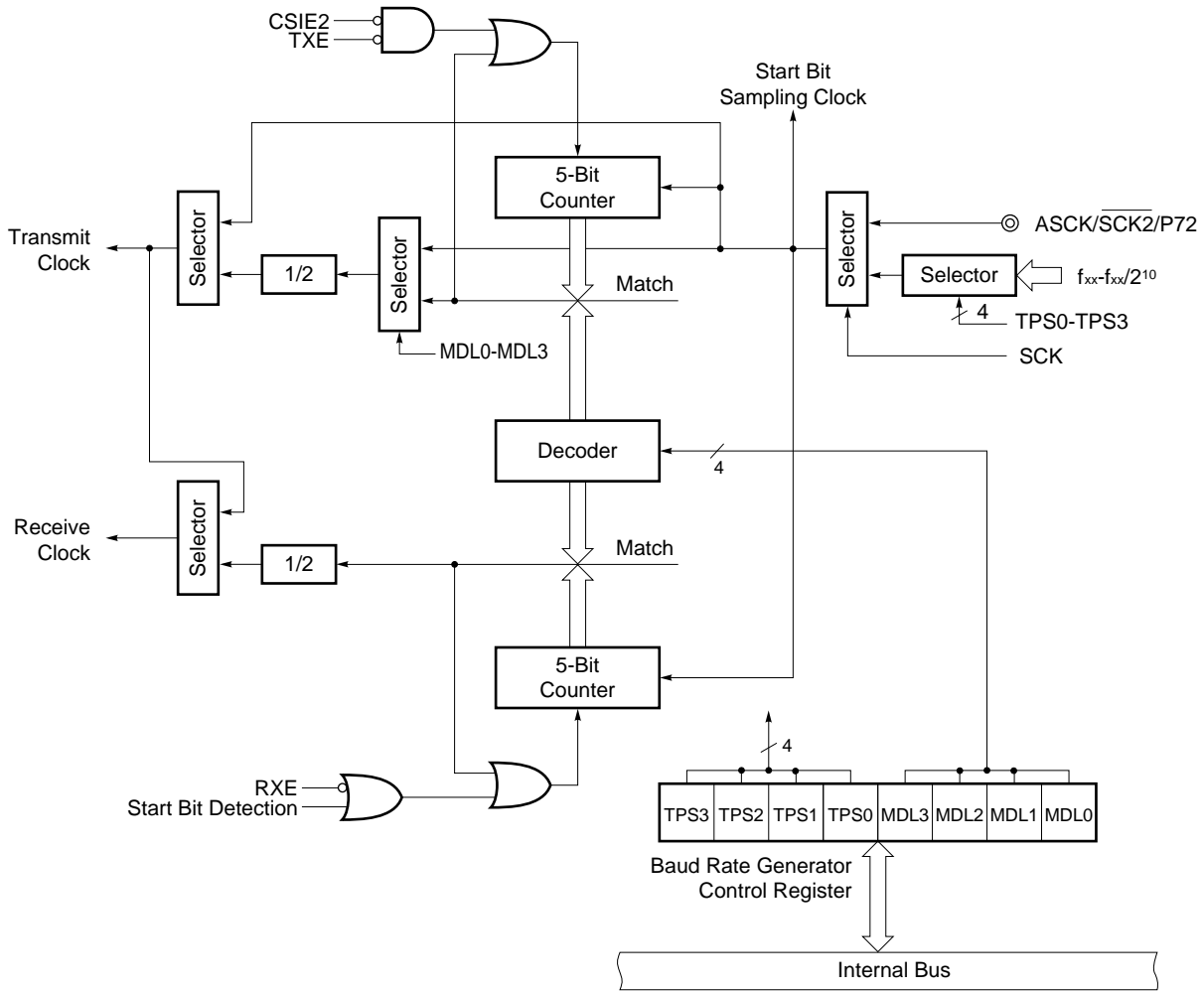
Note Refer to Figure 6-15 Block Diagram of P70 and Figure 6-16 Block Diagram of P71, P72.

Figure 19-1. Serial Interface Channel 2 Block Diagram



Note See Figure 19-2 for the baud rate generator configuration.

Figure 19-2. Baud Rate Generator Block Diagram



(1) Transmit shift register (TXS)

This register is used to set the transmit data. The data written in TXS is transmitted as serial data. If the data length is specified as 7 bits, bits 0 to 6 of the data written in TXS are transferred as transmit data. Writing data to TXS starts the transmit operation. TXS is written to with an 8-bit memory manipulation instruction. It cannot be read. TXS value is FFH after $\overline{\text{RESET}}$ input.

Caution Do not write a data to TXS during a transmit operation. TXS and the receive buffer register (RXB) are allocated to the same address, and when a read is performed, the value of RXB is read.

(2) Receive shift register (RXS)

This register is used to convert serial data input to the RxD pin to parallel data. When one byte of data is received, the receive data is transferred to the receive buffer register (RXB). RXS cannot be directly manipulated by a program.

(3) Receive buffer register (RXB)

This register holds receive data. Each time one byte of data is received, new receive data is transferred from the receive shift register (RXS). If the data length is specified as 7 bits, the receive data is transferred to bits 0 to 6 of RXB, and the MSB of RXB is always set to 0. RXB is read with an 8-bit memory manipulation instruction. It cannot be written to. RXB value is FFH after $\overline{\text{RESET}}$ input.

Caution Since RXB and the transmit shift register (TXS) are allocated to the same address, even if a write instruction to RXB is executed, the value is written to TXS.

(4) Transmission control circuit

This circuit performs transmit operation control such as the addition of a start bit, parity bit and stop bit to data written in the transmit shift register (TXS) in accordance with the contents set in the asynchronous serial interface mode register (ASIM).

(5) Reception control circuit

This circuit controls receive operations in accordance with the contents set in the asynchronous serial interface mode register (ASIM). It also checks errors such as parity error during a receive operation, and if an error is detected, sets a value in the asynchronous serial interface status register (ASIS) in accordance with the error contents.

19.3 Serial Interface Channel 2 Control Registers

Serial interface channel 2 is controlled by the following four registers.

- Serial Operating Mode Register 2 (CSIM2)
- Asynchronous Serial Interface Mode Register (ASIM)
- Asynchronous Serial Interface Status Register (ASIS)
- Baud Rate Generator Control Register (BRGC)

(1) Serial operating mode register 2 (CSIM2)

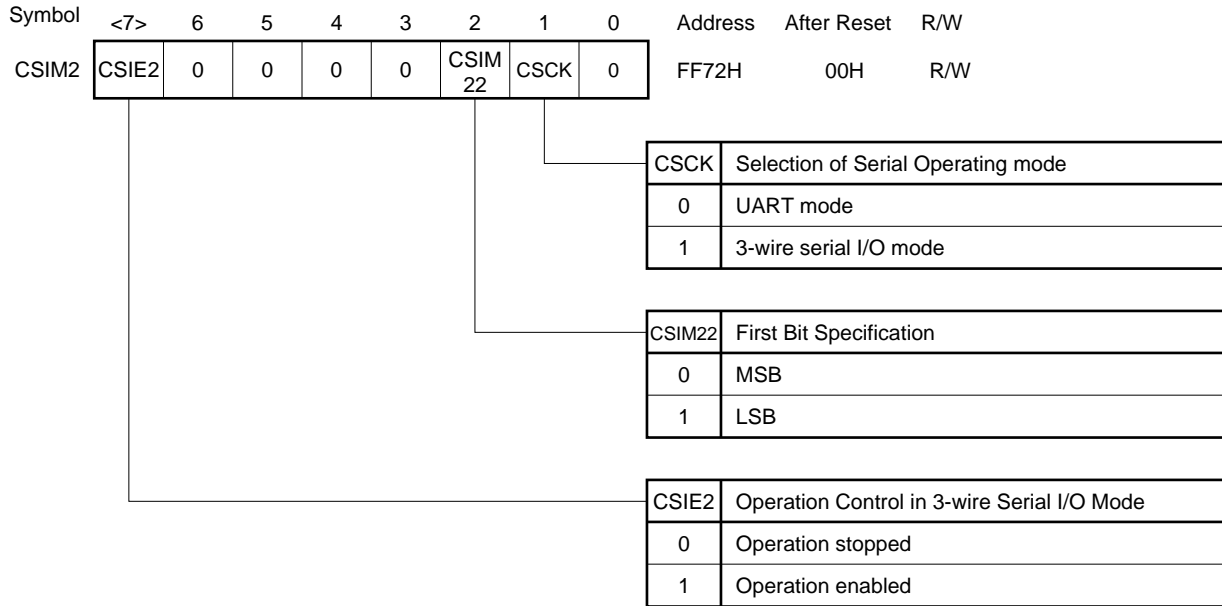
This register is set when serial interface channel 2 is used in the 3-wire serial I/O mode.

CSIM2 is set with a 1-bit or 8-bit memory manipulation instruction.

$\overline{\text{RESET}}$ input sets CSIM2 to 00H.

★

Figure 19-3. Serial Operating Mode Register 2 Format



- Cautions**
1. Ensure that bits 0 and 3 to 6 are set to 0.
 2. When UART mode is selected, CSIM2 should be set to 00H.

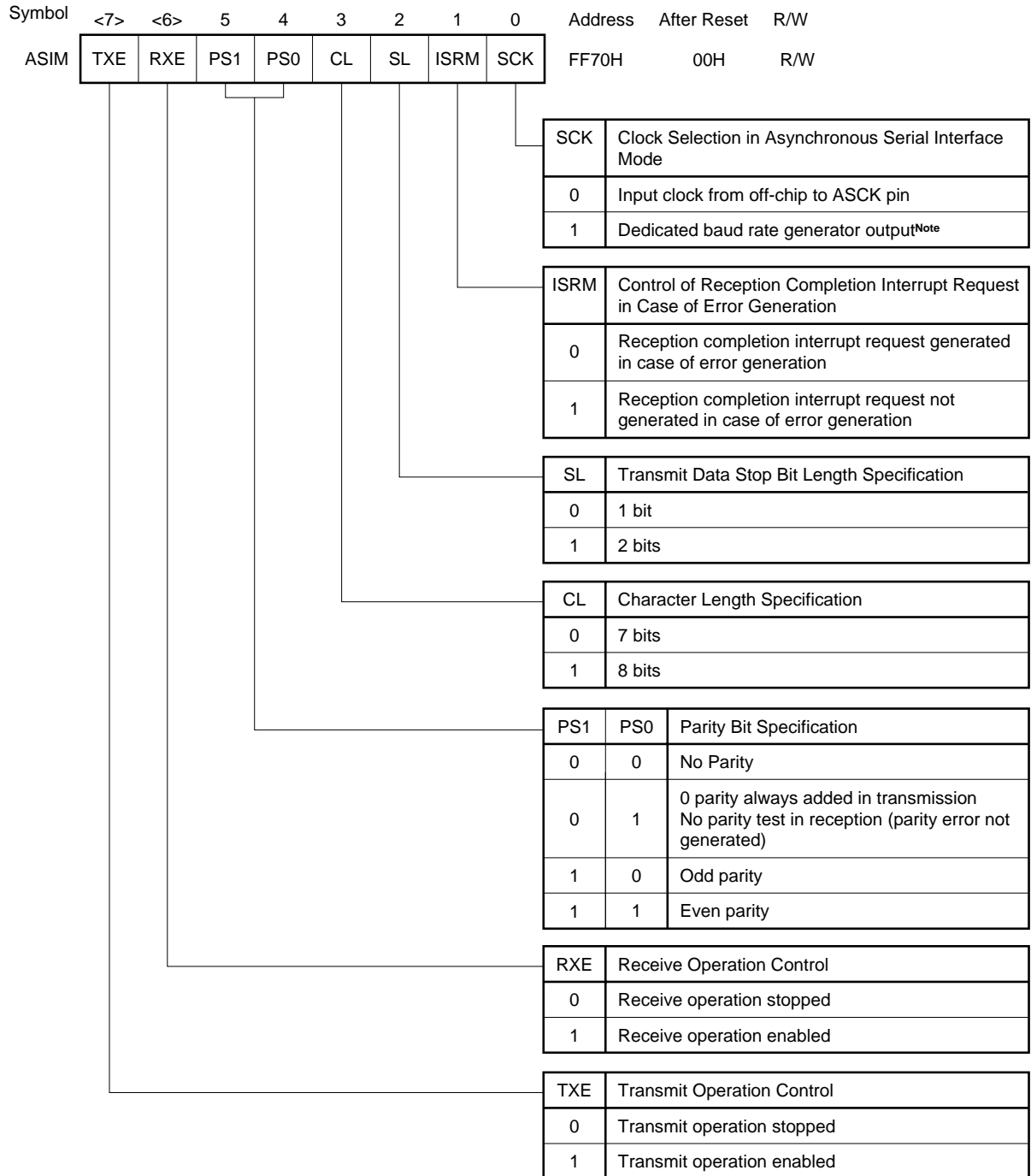
(2) Asynchronous serial interface mode register (ASIM)

This register is set when serial interface channel 2 is used in the asynchronous serial interface mode.

ASIM is set with a 1-bit or 8-bit memory manipulation instruction.

$\overline{\text{RESET}}$ input sets ASIM to 00H.

Figure 19-4. Asynchronous Serial Interface Mode Register Format



Note When SCK is set to 1 and the baud rate generator output is selected, the ASCK pin can be used as an input/output port.

- Cautions**
1. When the 3-wire serial I/O mode is selected, 00H should be set in ASIM.
 2. The serial transmit/receive operation must be stopped before changing the operating mode.

Table 19-2. Serial Interface Channel 2 Operating Mode Settings

(1) Operation Stop Mode

ASIM			CSIM2			PM70	P70	PM71	P71	PM72	P72	Start Bit	Shift Clock	P70/SI2 /RxD Pin Functions	P71/SO2 /TxD Pin Functions	P72/SCK2 /ASCK Pin Functions
TXE	RXE	SCK	CSIE2	CSIM22	CSCK											
0	0	×	0	×	×	×	×	×	×	×	×	—	—	P70	P71	P72
Other than above												Setting prohibited				

★ (2) 3-wire Serial I/O Mode

ASIM			CSIM2			PM70	P70	PM71	P71	PM72	P72	Start Bit	Shift Clock	P70/SI2 /RxD Pin Functions	P71/SO2 /TxD Pin Functions	P72/SCK2 /ASCK Pin Functions
TXE	RXE	SCK	CSIE2	CSIM22	CSCK											
0	0	0	1	0	1	1 ^{Note2}	×	0	1	0	1	MSB	Internal clock	S12 ^{Note2}	S02 (CMOS output)	SCK2 output
			1	1	1									LSB	S12 ^{Note2}	
Other than above												Setting prohibited				

(3) Asynchronous Serial Interface Mode

ASIM			CSIM2			PM70	P70	PM71	P71	PM72	P72	Start Bit	Shift Clock	P70/SI2 /RxD Pin Functions	P71/SO2 /TxD Pin Functions	P72/SCK2 /ASCK Pin Functions
TXE	RXE	SCK	CSIE2	CSIM22	CSCK											
1	0	0	0	0	0	×	×	0	1	1	×	LSB	External clock	P70	TxD (CMOS output)	ASCK input
		1											Internal clock			P72
0	1	0	0	0	0	1	×	×	×	1	×	External clock	RxD	P71	ASCK input	
		1														Internal clock
1	1	0	0	0	0	1	×	0	1	1	×	External clock	Internal clock	TxD (CMOS output)	ASCK input	
		1													Internal clock	P72
Other than above												Setting prohibited				

Notes 1. Can be used freely as port function.

2. Can be used as P70 (CMOS input/output) when only transmitter is used.

Remark × : Don't care

PM_{xx} : Port mode register

P_{xx} : Port output latch

(3) Asynchronous serial interface status register (ASIS)

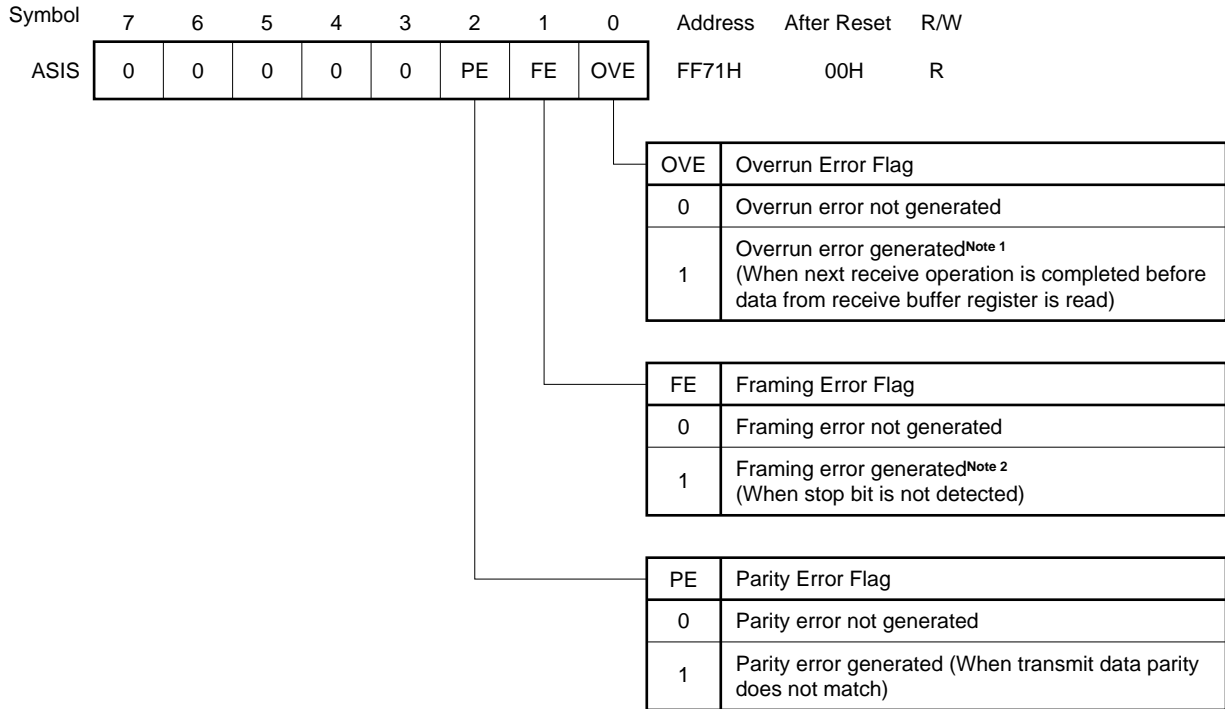
This is a register which displays the type of error when a reception error is generated in the asynchronous serial interface mode.

ASIS is read with a 8-bit memory manipulation instruction.

In 3-wire serial I/O mode, the contents of the ASIS are undefined.

$\overline{\text{RESET}}$ input sets ASIS to 00H.

Figure 19-5. Asynchronous Serial Interface Status Register Format



- Notes**
1. The receive buffer register (RXB) must be read when an overrun error is generated. Overrun errors will continue to be generated until RXB is read.
 2. Even if the stop bit length has been set as 2 bits by bit 2 (SL) of the asynchronous serial interface mode register (ASIM), only single stop bit detection is performed during reception.

(4) Baud rate generator control register (BRGC)

This register sets the serial clock for serial interface channel 2.

BRGC is set with an 8-bit memory manipulation instruction.

RESET input sets BRGC to 00H.

Figure 19-6. Baud Rate Generator Control Register Format (1/2)

Symbol	7	6	5	4	3	2	1	0	Address	After Reset	R/W
BRGC	TPS3	TPS2	TPS1	TPS0	MDL3	MDL2	MDL1	MDL0	FF73H	00H	R/W

MDL3	MDL2	MDL1	MDL0	Baud Rate Generator Input Clock Selection	k
0	0	0	0	f _{sck} /16	0
0	0	0	1	f _{sck} /17	1
0	0	1	0	f _{sck} /18	2
0	0	1	1	f _{sck} /19	3
0	1	0	0	f _{sck} /20	4
0	1	0	1	f _{sck} /21	5
0	1	1	0	f _{sck} /22	6
0	1	1	1	f _{sck} /23	7
1	0	0	0	f _{sck} /24	8
1	0	0	1	f _{sck} /25	9
1	0	1	0	f _{sck} /26	10
1	0	1	1	f _{sck} /27	11
1	1	0	0	f _{sck} /28	12
1	1	0	1	f _{sck} /29	13
1	1	1	0	f _{sck} /30	14
1	1	1	1	f _{sck} ^{Note}	—

Note Can only be used in 3-wire serial I/O mode.

- Remarks**
1. f_{sck} : 5-bit counter source clock
 2. k : Value set in MDL0 to MDL3 (0 ≤ k ≤ 14)

Figure 19-6. Baud Rate Generator Control Register Format (2/2)

TPS3	TPS2	TPS1	TPS0	5-Bit Counter Source Clock Selection				n
				MCS = 1		MCS = 0		
0	0	0	0	$f_{xx}/2^{10}$	$f_{xx}/2^{10}$ (4.9 kHz)	$f_x/2^{11}$ (2.4 kHz)		11
0	1	0	1	f_{xx}	f_x (5.0 MHz)	$f_x/2$ (2.5 MHz)		1
0	1	1	0	$f_{xx}/2$	$f_x/2$ (2.5 MHz)	$f_x/2^2$ (1.25 MHz)		2
0	1	1	1	$f_{xx}/2^2$	$f_x/2^2$ (1.25 MHz)	$f_x/2^3$ (625 kHz)		3
1	0	0	0	$f_{xx}/2^3$	$f_x/2^3$ (625 kHz)	$f_x/2^4$ (313 kHz)		4
1	0	0	1	$f_{xx}/2^4$	$f_x/2^4$ (313 kHz)	$f_x/2^5$ (156 kHz)		5
1	0	1	0	$f_{xx}/2^5$	$f_x/2^5$ (156 kHz)	$f_x/2^6$ (78.1 kHz)		6
1	0	1	1	$f_{xx}/2^6$	$f_x/2^6$ (78.1 kHz)	$f_x/2^7$ (39.1 kHz)		7
1	1	0	0	$f_{xx}/2^7$	$f_x/2^7$ (39.1 kHz)	$f_x/2^8$ (19.5 kHz)		8
1	1	0	1	$f_{xx}/2^8$	$f_x/2^8$ (19.5 kHz)	$f_x/2^9$ (9.8 kHz)		9
1	1	1	0	$f_{xx}/2^9$	$f_x/2^9$ (9.8 kHz)	$f_x/2^{10}$ (4.9 kHz)		10
Other than above				Setting prohibited				

Caution When data is written to BRGC during a communication operation, baud rate generator output is disrupted and communication cannot be performed normally. Therefore, data must not be written to BRGC during a communication operation.

- Remarks**
1. f_x : Main system clock oscillation frequency
 2. f_{xx} : Main system clock frequency (f_x or $f_x/2$)
 3. MCS : Oscillation mode selection register (OSMS) bit 0
 4. n : Value set in TPS0 to TPS3 ($1 \leq n \leq 11$)
 5. Figures in parentheses apply to operation with $f_x = 5.0$ MHz

The baud rate transmit/receive clock generated is either a signal scaled from the main system clock, or a signal scaled from the clock input from the ASCK pin.

(a) Generation of baud rate transmit/receive clock by means of main system clock

The transmit/receive clocks generated by scaling the main system clock. The baud rate generated from the main system clock is found from the following expression.

$$[\text{Baud rate}] = \frac{f_{xx}}{2^n \times (k+16)} \text{ [Hz]}$$

- where,
- f_x : Main system clock oscillation frequency
 - f_{xx} : Main system clock frequency (f_x or $f_x/2$)
 - n : Value set in TPS0 to TPS3 ($1 \leq n \leq 11$)
 - k : Value set in MDL0 to MDL3 ($0 \leq k \leq 14$)

Table 19-3. Relation between Main System Clock and Baud Rate

Baud Rate (bps)	fx = 5.0 MHz				fx = 4.19 MHz			
	MCS = 1		MCS = 0		MCS = 1		MCS = 0	
	BRGC Set Value	Error (%)	BRGC Set Value	Error (%)	BRGC Set Value	Error (%)	BRGC Set Value	Error (%)
75	—		00H	1.73	0BH	1.14	EBH	1.14
110	06H	0.88	E6H	0.88	03H	-2.01	E3H	-2.01
150	00H	1.73	E0H	1.73	EBH	1.14	DBH	1.14
300	E0H	1.73	D0H	1.73	DBH	1.14	CBH	1.14
600	D0H	1.73	C0H	1.73	CBH	1.14	BBH	1.14
1200	C0H	1.73	B0H	1.73	BBH	1.14	ABH	1.14
2400	B0H	1.73	A0H	1.73	ABH	1.14	9BH	1.14
4800	A0H	1.73	90H	1.73	9BH	1.14	8BH	1.14
9600	90H	1.73	80H	1.73	8BH	1.14	7BH	1.14
19200	80H	1.73	70H	1.73	7BH	1.14	6BH	1.14
31250	74H	0	64H	0	71H	-1.31	61H	-1.31
38400	70H	1.73	60H	1.73	6BH	1.14	5BH	1.14
76800	60H	1.73	50H	1.73	5BH	1.14	—	—

Remark MCS: Oscillation mode selection register bit 0

(b) Generation of baud rate transmit/receive clock by means of external clock from ASCK pin

The transmit/receive clock is generated by scaling the clock input from the ASCK pin. The baud rate generated from the clock input from the ASCK pin is obtained with the following expression.

$$[\text{Baud rate}] = \frac{f_{\text{ASCK}}}{2 \times (k+16)} \text{ [Hz]}$$

f_{ASCK} : Frequency of clock input to ASCK pin

k : Value set in MDL0 to MDL3 ($0 \leq k \leq 14$)

Table 19-4. Relation between ASCK Pin Input Frequency and Baud Rate (When BRGC is set to 00H)

Baud Rate (bps)	ASCK Pin Input Frequency
75	2.4 kHz
110	3.52 kHz
150	4.8 kHz
300	9.6 kHz
600	19.2 kHz
1200	38.4 kHz
2400	76.8 kHz
4800	153.6 kHz
9600	307.2 kHz
19200	614.4 kHz
31250	1000.0 kHz
38400	1228.8 kHz

19.4 Serial Interface Channel 2 Operation

Serial interface channel 2 has the following three modes.

- Operation stop mode
- Asynchronous serial interface (UART) mode
- 3-wire serial I/O mode

19.4.1 Operation stop mode

In the operation stop mode, serial transfer is not performed, and therefore power consumption can be reduced.

In the operation stop mode, the P70/SI2/RxD, P71/SO2/TxD and P72/ $\overline{\text{SCK2}}$ /ASCK pins can be used as normal input/output ports.

(1) Register setting

Operation stop mode settings are performed using serial operating mode register 2 (CSIM2) and the asynchronous serial interface mode register (ASIM).

(a) Serial operating mode register 2 (CSIM2)

CSIM2 is set with a 1-bit or 8-bit memory manipulation instruction.

$\overline{\text{RESET}}$ input sets CSIM2 to 00H.

Symbol	<7>	6	5	4	3	2	1	0	Address	After Reset	R/W
CSIM2	CSIE2	0	0	0	0	CSIM 22	CSCK	0	FF72H	00H	R/W

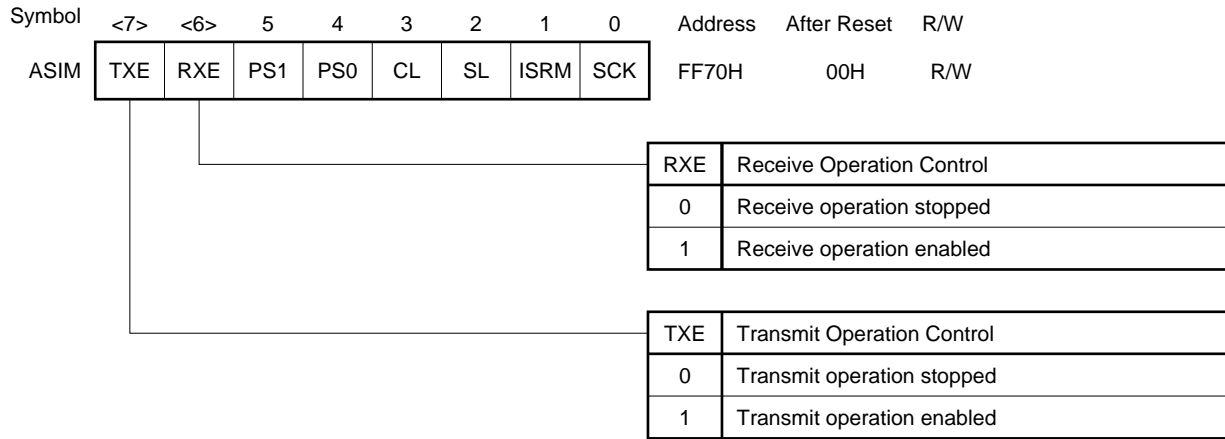
CSIE2	Operation Control in 3-wire Serial I/O Mode
0	Operation stopped
1	Operation enabled

Caution Ensure that bits 0 and 3 to 6 are set to 0.

(b) Asynchronous serial interface mode register (ASIM)

ASIM is set with a 1-bit or 8-bit memory manipulation instruction.

$\overline{\text{RESET}}$ input sets ASIM to 00H.



19.4.2 Asynchronous serial interface (UART) mode

In this mode, one byte of data is transmitted/received following the start bit, and full-duplex operation is possible. A dedicated UART baud rate generator is incorporated, allowing communication over a wide range of baud rates. In addition, the baud rate can be defined also by scaling the input clock to the ASCK pin.

The MIDI standard baud rate (31.25 kbps) can also be used by employing the dedicated UART baud rate generator.

(1) Register setting

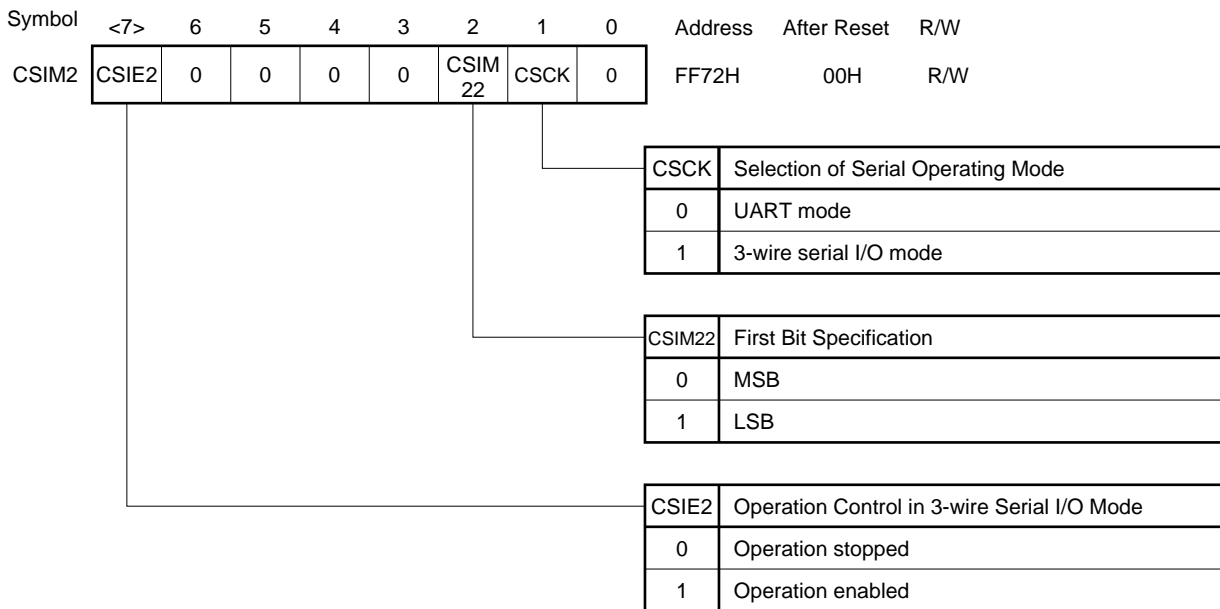
UART mode settings are performed using serial operating mode register 2 (CSIM2), the asynchronous serial interface mode register (ASIM), the asynchronous serial interface status register (ASIS), and the baud rate generator control register (BRGC).

(a) Serial operating mode register 2 (CSIM2)

CSIM2 is set with a 1-bit or 8-bit memory manipulation instruction.

RESET input sets CSIM2 to 00H.

When the UART mode is selected, 00H should be set in CSIM2.

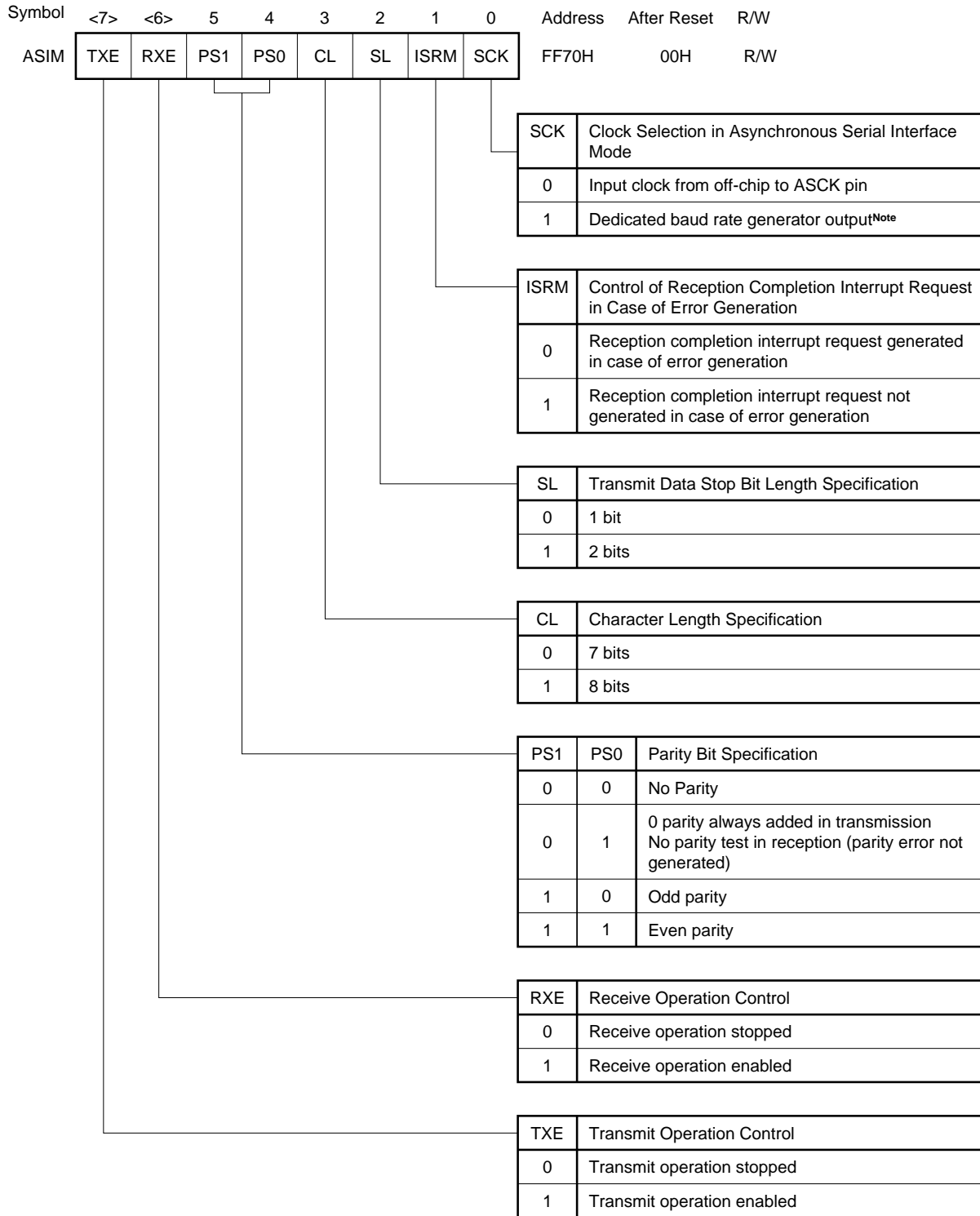


Caution Ensure that bits 0 and 3 to 6 are set to 0.

(b) Asynchronous serial interface mode register (ASIM)

ASIM is set with a 1-bit or 8-bit memory manipulation instruction.

$\overline{\text{RESET}}$ input sets ASIM to 00H.



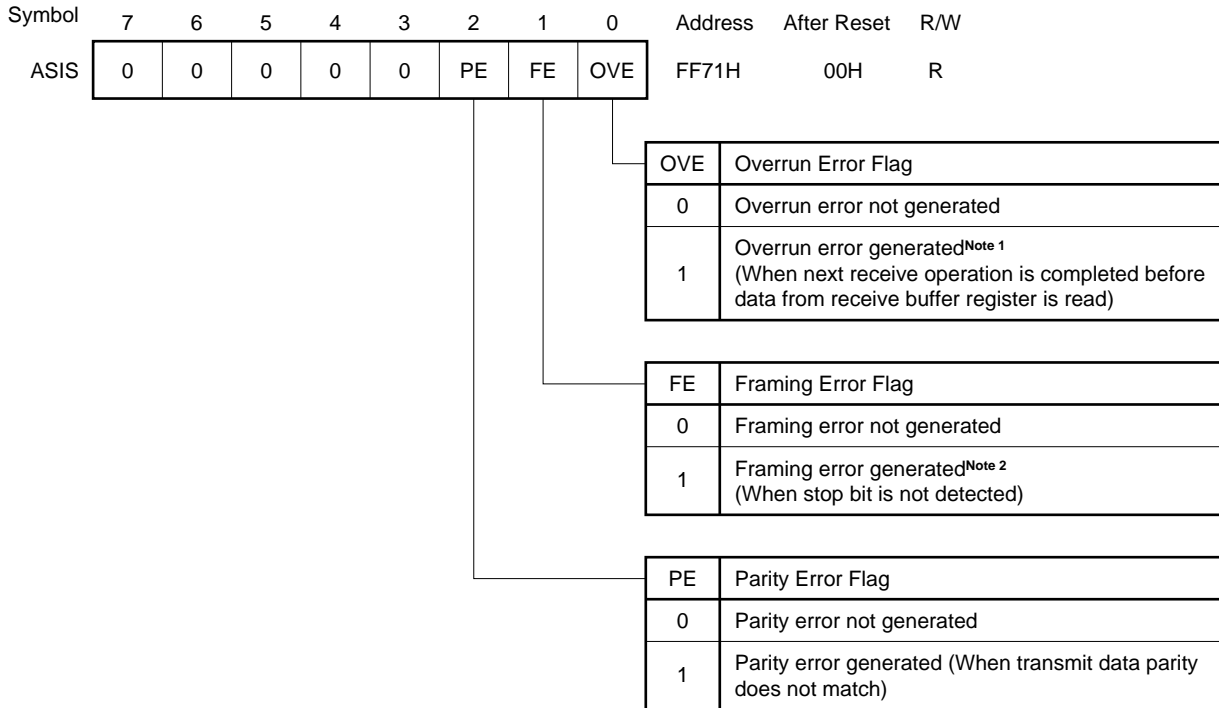
Note When SCK is set to 1 and the baud rate generator output is selected, the ASCK pin can be used as an input/output port.

Caution The serial transmit/receive operation must be stopped before changing the operating mode.

(c) Asynchronous serial interface status register (ASIS)

ASIS is set with a 1-bit or 8-bit memory manipulation instruction.

$\overline{\text{RESET}}$ input sets ASIS to 00H.



- Notes**
1. The receive buffer register (RXB) must be read when an overrun error is generated. Overrun errors will continue to be generated until RXB is read.
 2. Even if the stop bit length has been set as 2 bits by bit 2 (SL) of the asynchronous serial interface mode register (ASIM), only single stop bit detection is performed during reception.

(d) Baud rate generator control register (BRGC)

BRGC is set with an 8-bit memory manipulation instruction.

$\overline{\text{RESET}}$ input sets BRGC to 00H.

Symbol	7	6	5	4	3	2	1	0	Address	After Reset	R/W
BRGC	TPS3	TPS2	TPS1	TPS0	MDL3	MDL2	MDL1	MDL0	FF73H	00H	R/W

MDL3	MDL2	MDL1	MDL0	Baud Rate Generator Input Clock Selection	k
0	0	0	0	f _{sck} /16	0
0	0	0	1	f _{sck} /17	1
0	0	1	0	f _{sck} /18	2
0	0	1	1	f _{sck} /19	3
0	1	0	0	f _{sck} /20	4
0	1	0	1	f _{sck} /21	5
0	1	1	0	f _{sck} /22	6
0	1	1	1	f _{sck} /23	7
1	0	0	0	f _{sck} /24	8
1	0	0	1	f _{sck} /25	9
1	0	1	0	f _{sck} /26	10
1	0	1	1	f _{sck} /27	11
1	1	0	0	f _{sck} /28	12
1	1	0	1	f _{sck} /29	13
1	1	1	0	f _{sck} /30	14

(continued)

Remark f_{sck} : 5-bit counter source clock
 k : Value set in MDL0 to MDL3 (0 ≤ k ≤ 14)

TPS3	TPS2	TPS1	TPS0	5-Bit Counter Source Clock Selection				n
				MCS = 1		MCS = 0		
0	0	0	0	$f_{xx}/2^{10}$	$f_x/2^{10}$ (4.9 kHz)	$f_x/2^{11}$ (2.4 kHz)	11	
0	1	0	1	f_{xx}	f_x (5.0 MHz)	$f_x/2$ (2.5 MHz)	1	
0	1	1	0	$f_{xx}/2$	$f_x/2$ (2.5 MHz)	$f_x/2^2$ (1.25 MHz)	2	
0	1	1	1	$f_{xx}/2^2$	$f_x/2^2$ (1.25 MHz)	$f_x/2^3$ (625 kHz)	3	
1	0	0	0	$f_{xx}/2^3$	$f_x/2^3$ (625 kHz)	$f_x/2^4$ (313 kHz)	4	
1	0	0	1	$f_{xx}/2^4$	$f_x/2^4$ (313 kHz)	$f_x/2^5$ (156 kHz)	5	
1	0	1	0	$f_{xx}/2^5$	$f_x/2^5$ (156 kHz)	$f_x/2^6$ (78.1 kHz)	6	
1	0	1	1	$f_{xx}/2^6$	$f_x/2^6$ (78.1 kHz)	$f_x/2^7$ (39.1 kHz)	7	
1	1	0	0	$f_{xx}/2^7$	$f_x/2^7$ (39.1 kHz)	$f_x/2^8$ (19.5 kHz)	8	
1	1	0	1	$f_{xx}/2^8$	$f_x/2^8$ (19.5 kHz)	$f_x/2^9$ (9.8 kHz)	9	
1	1	1	0	$f_{xx}/2^9$	$f_x/2^9$ (9.8 kHz)	$f_x/2^{10}$ (4.9 kHz)	10	
Other than above				Setting prohibited				

Caution When a data is written to BRGC during a communication operation, baud rate generator output is disrupted and communication cannot be performed normally. Therefore, data must not be written to BRGC during a communication operation.

- Remarks**
1. f_x : Main system clock oscillation frequency
 2. f_{xx} : Main system clock frequency (f_x or $f_x/2$)
 3. MCS : Oscillation mode selection register (OSMS) bit 0
 4. n : Value set in TPS0 to TPS3 ($1 \leq n \leq 11$)
 5. Figures in parentheses apply to operation with $f_x = 5.0$ MHz.

The baud rate transmit/receive clock generated is either a signal scaled from the main system clock, or a signal scaled from the clock input from the ASCK pin.

(i) Generation of baud rate transmit/receive clock by means of main system clock

The transmit/receive clock is generated by scaling the main system clock. The baud rate generated from the main system clock is obtained with the following expression.

$$[\text{Baud rate}] = \frac{f_{xx}}{2^n \times (k+16)} \text{ [Hz]}$$

- where,
- f_x : Main system clock oscillation frequency
 - f_{xx} : Main system clock frequency (f_x or $f_x/2$)
 - n : Value set in TPS0 to TPS3 ($1 \leq n \leq 11$)
 - k : Value set in MDL0 to MDL3 ($0 \leq k \leq 14$)

Table 19-5. Relation between Main System Clock and Baud Rate

Baud Rate (bps)	fx = 5.0 MHz				fx = 4.19 MHz			
	MCS = 1		MCS = 0		MCS = 1		MCS = 0	
	BRGC Set Value	Error (%)	BRGC Set Value	Error (%)	BRGC Set Value	Error (%)	BRGC Set Value	Error (%)
75	—		00H	1.73	0BH	1.14	EBH	1.14
110	06H	0.88	E6H	0.88	03H	-2.01	E3H	-2.01
150	00H	1.73	E0H	1.73	EBH	1.14	DBH	1.14
300	E0H	1.73	D0H	1.73	DBH	1.14	CBH	1.14
600	D0H	1.73	C0H	1.73	CBH	1.14	BBH	1.14
1200	C0H	1.73	B0H	1.73	BBH	1.14	ABH	1.14
2400	B0H	1.73	A0H	1.73	ABH	1.14	9BH	1.14
4800	A0H	1.73	90H	1.73	9BH	1.14	8BH	1.14
9600	90H	1.73	80H	1.73	8BH	1.14	7BH	1.14
19200	80H	1.73	70H	1.73	7BH	1.14	6BH	1.14
31250	74H	0	64H	0	71H	-1.31	61H	-1.31
38400	70H	1.73	60H	1.73	6BH	1.14	5BH	1.14
76800	60H	1.73	50H	1.73	5BH	1.14	—	—

Remark MCS: Oscillation mode selection register bit 0

(ii) Generation of baud rate transmit/receive clock by means of external clock from ASCK pin

The transmit/receive clock is generated by scaling the clock input from the ASCK pin. The baud rate generated from the clock input from the ASCK pin is obtained with the following expression.

$$[\text{Baud rate}] = \frac{f_{\text{ASCK}}}{2 \times (k+16)} \text{ [Hz]}$$

where, f_{ASCK} : Frequency of clock input to ASCK pin
 k : Value set in MDL0 to MDL3 ($0 \leq k \leq 14$)

Table 19-6. Relation between ASCK Pin Input Frequency and Baud Rate (When BRGC is set to 00H)

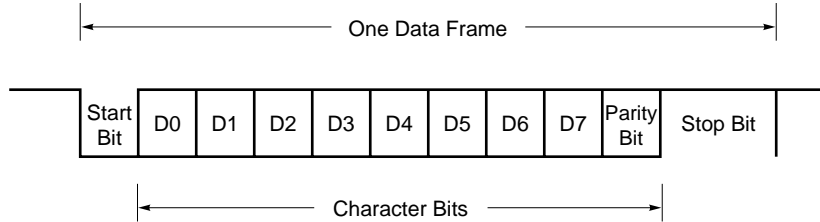
Baud Rate (bps)	ASCK Pin Input Frequency
75	2.4 kHz
110	3.52 kHz
150	4.8 kHz
300	9.6 kHz
600	19.2 kHz
1200	38.4 kHz
2400	76.8 kHz
4800	153.6 kHz
9600	307.2 kHz
19200	614.4 kHz
31250	1000.0 kHz
38400	1228.8 kHz

(2) Communication operation

(a) Data format

The transmit/receive data format is as shown in Figure 19-7.

Figure 19-7. Asynchronous Serial Interface Transmit/Receive Data Format



One data frame consists of the following bits.

- Start bits 1 bit
- Character bits 7 bits/8 bits
- Parity bits Even parity/odd parity/0 parity/no parity
- Stop bit(s) 1 bit/2 bits

The character bit length, parity, and stop bit length for each data frame are specified with asynchronous serial interface mode register (ASIM).

When 7 bits are selected as the number of character bits, only the lower 7 bits (bits 0 to 6) are valid; in transmission the most significant bit (bit 7) is ignored, and in reception the most significant bit (bit 7) is always "0".

The serial transfer rate is set with ASIM and the baud rate generator control register (BRGC).

If a serial data receive error is generated, the receive error contents can be determined by reading the status of the asynchronous serial interface status register (ASIS).

(b) Parity types and operation

The parity bit is used to detect a bit error in the communication data. Normally, the same kind of parity bit is used on the transmitting side and the receiving side. With even parity and odd parity, a one-bit (odd number) error can be detected. With 0 parity and no parity, an error cannot be detected.

(i) Even parity**• Transmission**

The number of bits with a value of “1”, including the parity bit, in the transmit data is controlled to be even.

The value of the parity bit is as follows:

Number of bits with a value of “1” in transmit data is odd : 1

Number of bits with a value of “1” in transmit data is even : 0

• Reception

The number of bits with a value of “1”, including the parity bit, in the receive data is counted. If it is odd, a parity error occurs.

(ii) Odd parity**• Transmission**

Conversely to the situation with even parity, the number of bits with a value of “1”, including the parity bit, in the transmit data is controlled to be odd. The value of the parity bit is as follows:

Number of bits with a value of “1” in transmit data is odd : 0

Number of bits with a value of “1” in transmit data is even : 1

• Reception

The number of bits with a value of “1”, including the parity bit, in the receive data is counted. If it is even, a parity error occurs.

(iii) 0 Parity

When transmitting, the parity bit is set to “0” irrespective of the transmit data.

At reception, a parity bit check is not performed. Therefore, a parity error is not generated, irrespective of whether the parity bit is set to “0” or “1”.

(iv) No parity

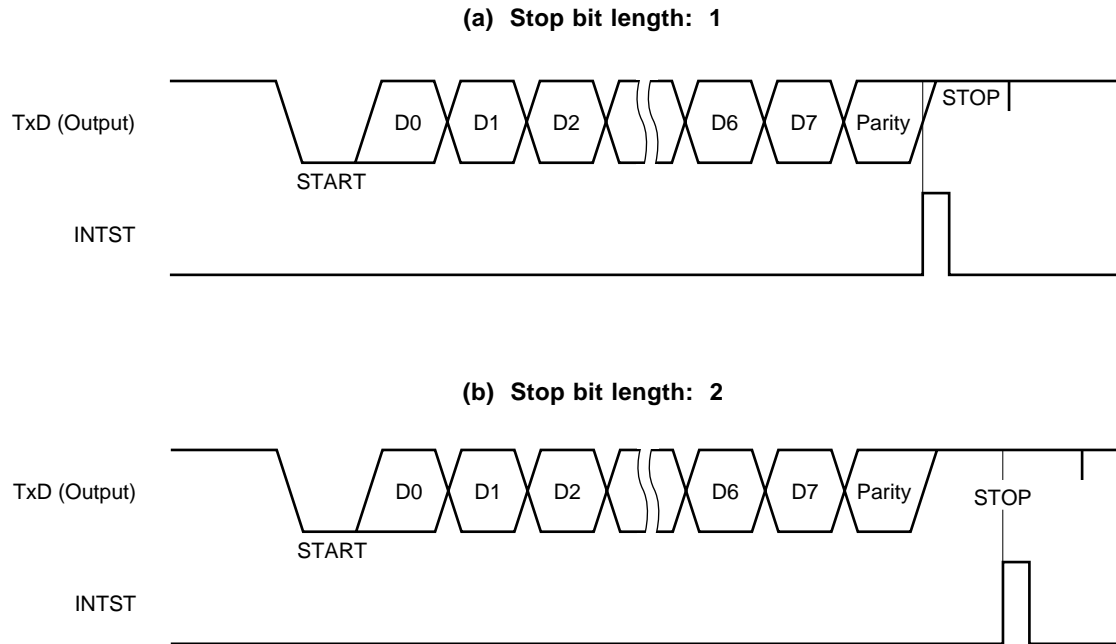
A parity bit is not added to the transmit data. At reception, data is received assuming that there is no parity bit. Since there is no parity bit, a parity error is not generated.

(c) Transmission

A transmit operation is started by writing transmit data to the transmit shift register (TXS). The start bit, parity bit and stop bit(s) are added automatically.

When the transmit operation starts, the data in the transmit shift register (TXS) is shifted out, and when the transmit shift register (TXS) is empty, a transmission completion interrupt request (INTST) is generated.

Figure 19-8. Asynchronous Serial Interface Transmission Completion Interrupt Request Generation Timing



Caution Do not rewrite the asynchronous serial interface mode register (ASIM) during a transmit operation. If rewriting of the ASIM register is performed during transmission, subsequent transmit operations may not be possible (the normal state is restored by $\overline{\text{RESET}}$ input).

Whether transmission is in progress or not can be determined by software using a transmission completion interrupt (INTST) or the interrupt request flag (STIF) set by the INTST.

(d) Reception

When the bit 6 (RXE) of the asynchronous serial interface mode register (ASIM) is set (1), a receive operation is enabled and sampling of the RxD pin input is performed.

RxD pin input sampling is performed using the serial clock specified by ASIM.

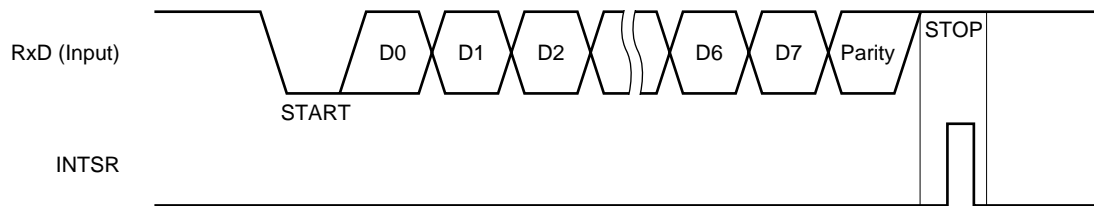
When the RxD pin input becomes low, the 5-bit counter of the baud rate generator (refer to Figure 19-2) starts counting, and at the time when the half time determined by specified baud rate has passed, the data sampling start timing signal is output. If the RxD pin input sampled again as a result of this start timing signal is low, it is identified as a start bit, the 5-bit counter is initialized and starts counting, and data sampling is performed. When character data, a parity bit and one stop bit are detected after the start bit, reception of one frame of data ends.

When one frame of data has been received, the receive data in the shift register is transferred to the receive buffer register (RXB), and a reception completion interrupt request (INTSR) is generated.

Even if an error is generated, the receive data in which the error was generated is transferred to RXB. If bit 1 (ISRM) of ASIM is cleared (0) when the error is generated, INTSR will be generated. If ISRM is set (1), INTSR will not be generated.

If the RXE bit is reset (0) during the receive operation, the receive operation is stopped immediately. In this case, the contents of RXB and ASIS are not changed, and INTSR and INTSER are not generated.

**Figure 19-9. Asynchronous Serial Interface Reception Completion
Interrupt Request Generation Timing**



Caution The receive buffer register (RXB) must be read even if a receive error is generated. If RXB is not read, an overrun error will be generated when the next data is received, and the receive error state will continue indefinitely.

(e) Receive errors

Three kinds of errors can occur during a receive operation: a parity error, framing error, or overrun error. When the data reception result error flag is set in the asynchronous serial interface status register (ASIS), a receive error interrupt request (INTSER) is generated. INTSER is generated before receive completion interrupt request (INTSR). Receive error causes are shown in Table 19-7.

What type of error was generated can be detected by reading the contents of ASIS in the reception error interrupt servicing (INTSER). (see **Figures 19-9** and **19-10**).

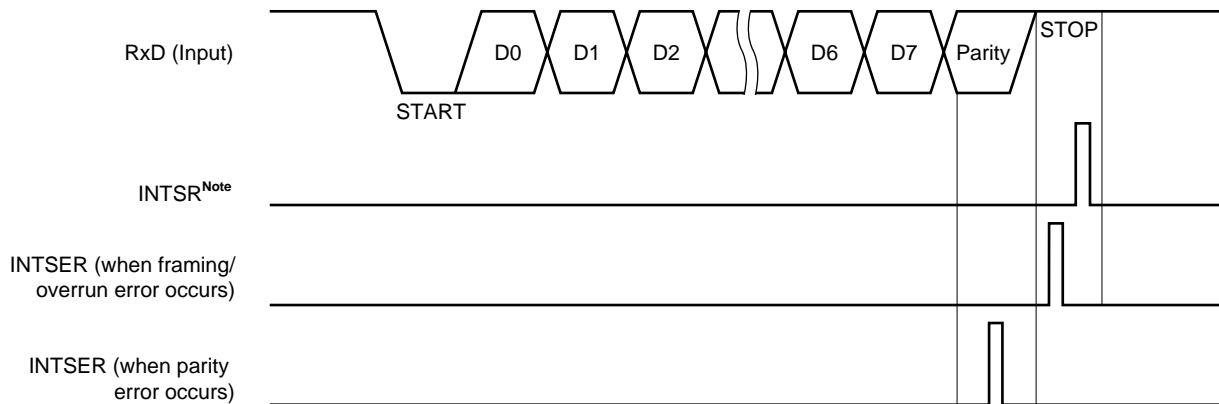
The contents of ASIS are reset (0) by reading the receive buffer register (RXB) or receiving the next data (if there is an error in the next data, the corresponding error flag is set).

Table 19-7. Receive Error Causes

Receive Errors	Cause
Parity error	Transmission-time parity specification and reception data parity do not match
Framing error	Stop bit not detected
Overrun error	Reception of next data is completed before data is read from receive register buffer

★

Figure 19-10. Receive Error Timing



Note If a reception error is generated while bit 1 (ISRM) of asynchronous serial interface mode register (ASIM) is set (1), INTSR will not be generated.

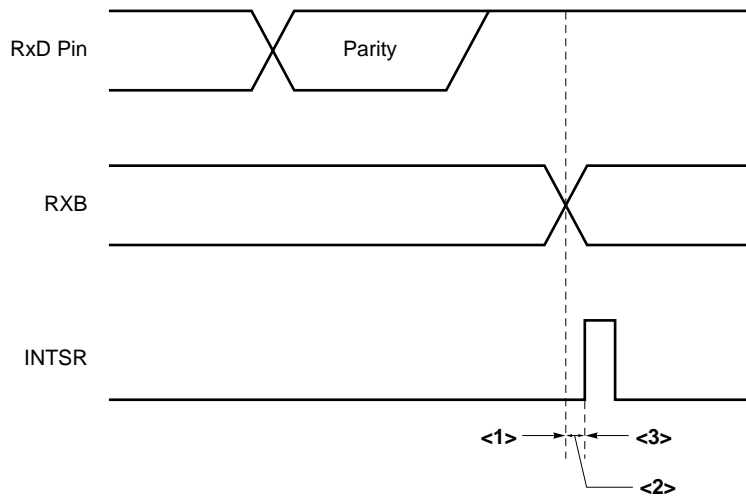
Cautions 1. The contents of the ASIS register are reset (0) by reading the receive buffer register (RXB) or receiving the next data. To ascertain the error contents, ASIS must be read before reading RXB.

2. The receive buffer register (RXB) must be read even if a receive error is generated. If RXB is not read, an overrun error will be generated when the next data is received, and the receive error state will continue indefinitely.

(3) UART mode cautions

- (a) When bit 7 (TXE) of the asynchronous serial interface mode register (ASIM) is cleared and the transmission operation is stopped during transmission, be sure to set the transmit shift register (TXS) to FFH, then set the TXE to 1 before executing the next transmission.
- (b) When bit 6 (RXE) of ASIM is cleared and the receive operation is stopped during reception, the state of the receive buffer register (RXB) and whether the receive completion interrupt request (INTSR) is generated depend on the timing of clearing. Figure 19-11 shows the timing.

Figure 19-11. The State of Receive Buffer Register (RXB) and Whether the Receive Completion Interrupt Request (INTSR) is Generated



When RXE is set to 0 at a time indicated by <1>, RXB holds the previous data and does not generate INTSR.
 When RXE is set to 0 at a time indicated by <2>, RXB renews the data and does not generate INTSR.
 When RXE is set to 0 at a time indicated by <3>, RXB renews the data and generates INTSR.

19.4.3 3-wire serial I/O mode

The 3-wire serial I/O mode is useful for connection of peripheral I/Os and display controllers, etc., which incorporate a conventional synchronous clocked serial interface, such as the 75X/XL series, 78K series, 17K series, etc.

Communication is performed using three lines: the serial clock ($\overline{\text{SCK2}}$), serial output (SO2), and serial input (SI2).

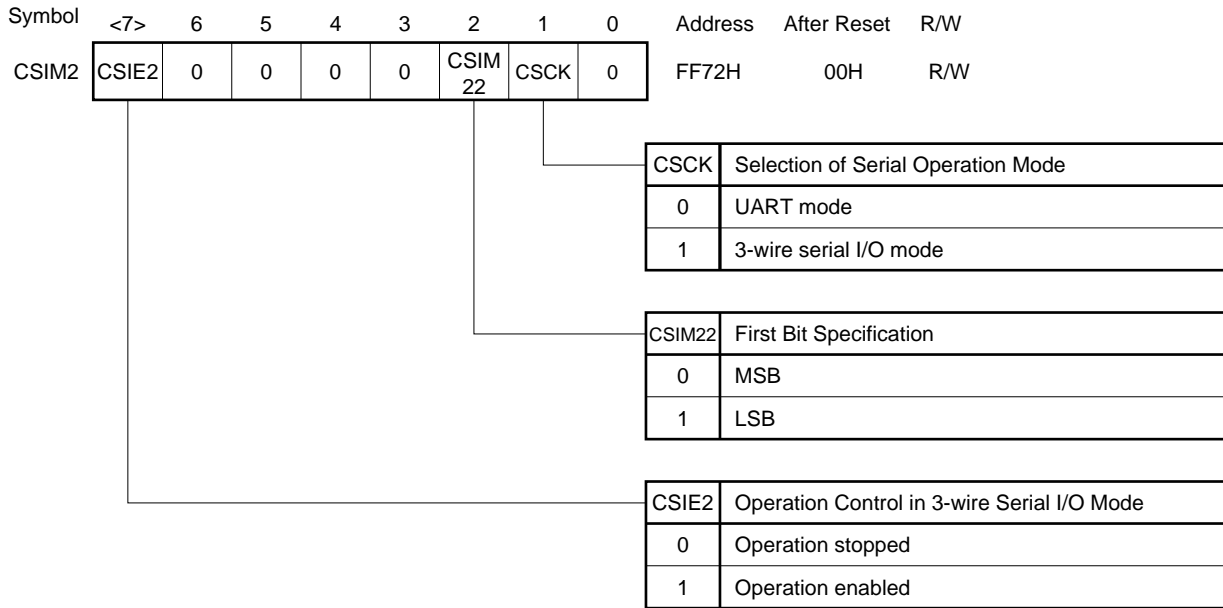
(1) Register setting

3-wire serial I/O mode settings are performed using serial operating mode register 2 (CSIM2), the asynchronous serial interface mode register (ASIM), and the baud rate generator control register (BRGC).

(a) Serial operating mode register 2 (CSIM2)

CSIM2 is set with a 1-bit or 8-bit memory manipulation instruction.

$\overline{\text{RESET}}$ input sets CSIM2 to 00H.



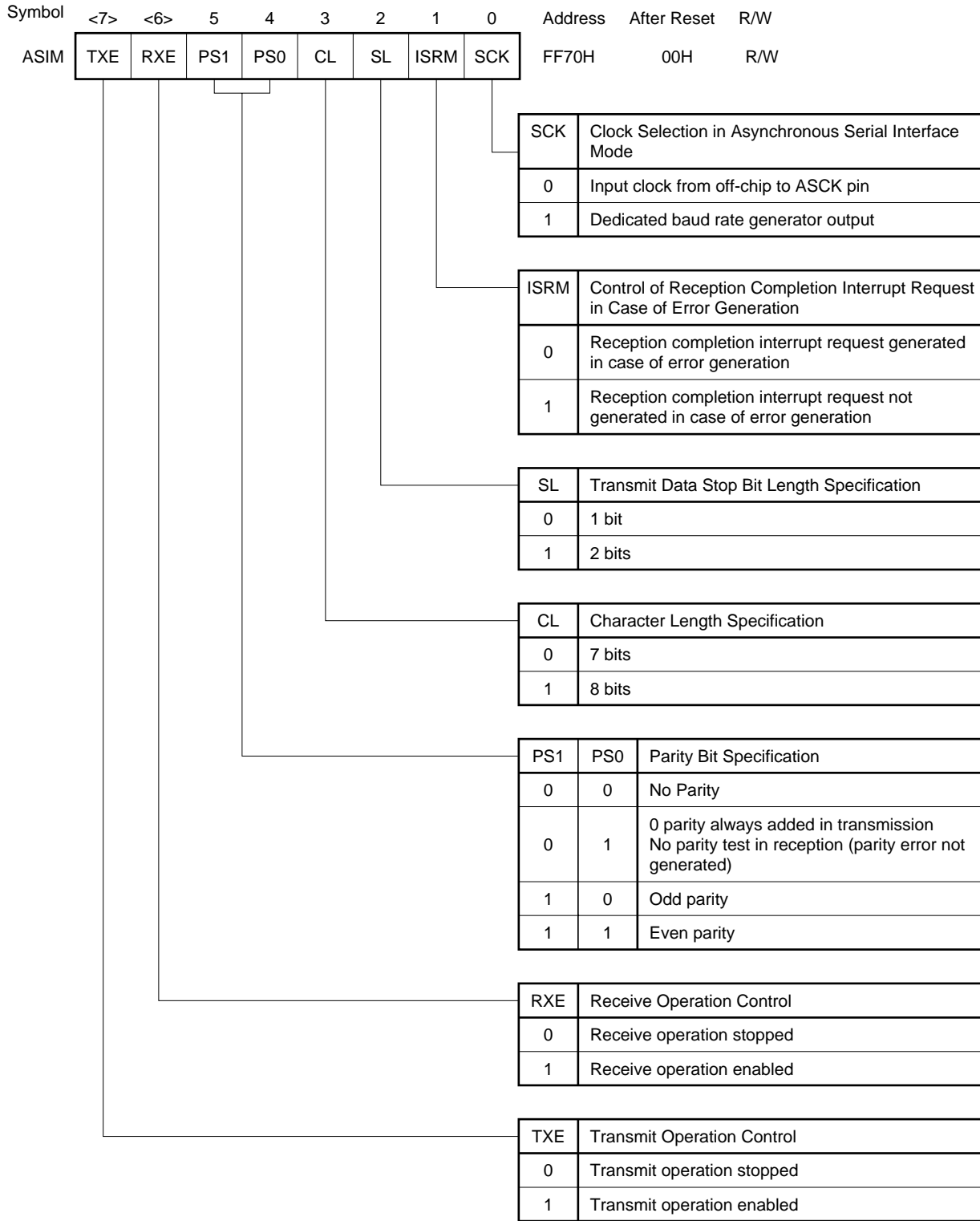
Caution Ensure that bits 0 and 3 to 6 are set to 0.

(b) Asynchronous serial interface mode register (ASIM)

ASIM is set with a 1-bit or 8-bit memory manipulation instruction.

$\overline{\text{RESET}}$ input sets ASIM to 00H.

When the 3-wire serial I/O mode is selected, 00H should be set in ASIM.



(c) Baud rate generator control register (BRGC)

BRGC is set with an 8-bit memory manipulation instruction.

$\overline{\text{RESET}}$ input sets BRGC to 00H.

Symbol	7	6	5	4	3	2	1	0	Address	After Reset	R/W
BRGC	TPS3	TPS2	TPS1	TPS0	MDL3	MDL2	MDL1	MDL0	FF73H	00H	R/W

MDL3	MDL2	MDL1	MDL0	Baud Rate Generator Input Clock Selection	k
0	0	0	0	f _{sck} /16	0
0	0	0	1	f _{sck} /17	1
0	0	1	0	f _{sck} /18	2
0	0	1	1	f _{sck} /19	3
0	1	0	0	f _{sck} /20	4
0	1	0	1	f _{sck} /21	5
0	1	1	0	f _{sck} /22	6
0	1	1	1	f _{sck} /23	7
1	0	0	0	f _{sck} /24	8
1	0	0	1	f _{sck} /25	9
1	0	1	0	f _{sck} /26	10
1	0	1	1	f _{sck} /27	11
1	1	0	0	f _{sck} /28	12
1	1	0	1	f _{sck} /29	13
1	1	1	0	f _{sck} /30	14
1	1	1	1	f _{sck}	—

Remark f_{sck} : 5-bit counter source clock
 k : Value set in MDL0 to MDL3 (0 ≤ k ≤ 14)

TPS3	TPS2	TPS1	TPS0	5-Bit Counter Source Clock Selection				n
				MCS = 1		MCS = 0		
0	0	0	0	$f_{xx}/2^{10}$	$f_x/2^{10}$ (4.9 kHz)	$f_x/2^{11}$ (2.4 kHz)		11
0	1	0	1	f_{xx}	f_x (5.0 MHz)	$f_x/2$ (2.5 MHz)		1
0	1	1	0	$f_{xx}/2$	$f_x/2$ (2.5 MHz)	$f_x/2^2$ (1.25 MHz)		2
0	1	1	1	$f_{xx}/2^2$	$f_x/2^2$ (1.25 MHz)	$f_x/2^3$ (625 kHz)		3
1	0	0	0	$f_{xx}/2^3$	$f_x/2^3$ (625 kHz)	$f_x/2^4$ (313 kHz)		4
1	0	0	1	$f_{xx}/2^4$	$f_x/2^4$ (313 kHz)	$f_x/2^5$ (156 kHz)		5
1	0	1	0	$f_{xx}/2^5$	$f_x/2^5$ (156 kHz)	$f_x/2^6$ (78.1 kHz)		6
1	0	1	1	$f_{xx}/2^6$	$f_x/2^6$ (78.1 kHz)	$f_x/2^7$ (39.1 kHz)		7
1	1	0	0	$f_{xx}/2^7$	$f_x/2^7$ (39.1 kHz)	$f_x/2^8$ (19.5 kHz)		8
1	1	0	1	$f_{xx}/2^8$	$f_x/2^8$ (19.5 kHz)	$f_x/2^9$ (9.8 kHz)		9
1	1	1	0	$f_{xx}/2^9$	$f_x/2^9$ (9.8 kHz)	$f_x/2^{10}$ (4.9 kHz)		10
Other than above				Setting prohibited				

Caution When a Data is written to BRGC during a communication operation, baud rate generator output is disrupted and communication cannot be performed normally. Therefore, data must not be written to BRGC during a communication operation.

- Remarks**
1. f_x : Main system clock oscillation frequency
 2. f_{xx} : Main system clock frequency (f_x or $f_x/2$)
 3. MCS : Oscillation mode selection register (OSMS) bit 0
 4. n : Value set in TPS0 to TPS3 ($1 \leq n \leq 11$)
 5. Figures in parentheses apply to operation with $f_x = 5.0$ MHz.

When the 3-wire serial I/O mode is used, set BRGC as described below.

(i) When the baud rate generator is not used:

Select a serial clock frequency with TPS0 to TPS3. Be sure then to set MDL0 to MDL3 to 1,1,1,1. The serial clock frequency becomes 1/2 of the source clock frequency for the 5-bit counter.

(ii) When the baud rate generator is used:

Select a serial clock frequency with TPS0 to TPS3. Be sure then to set MDL0 to MDL3 to 1,1,1,1.

The serial clock frequency is calculated by the following formula:

$$\text{Serial clock frequency} = \frac{f_{xx}}{2^n \times (k + 16)} \text{ [Hz]}$$

- Remarks**
1. f_x : Main system clock oscillation frequency
 2. f_{xx} : Main system clock frequency (f_x or $f_x/2$)
 3. n : Value set in TPS0 to TPS3 ($1 \leq n \leq 11$)
 4. k : Value set in MDL0 to MDL3 ($0 \leq k \leq 14$)

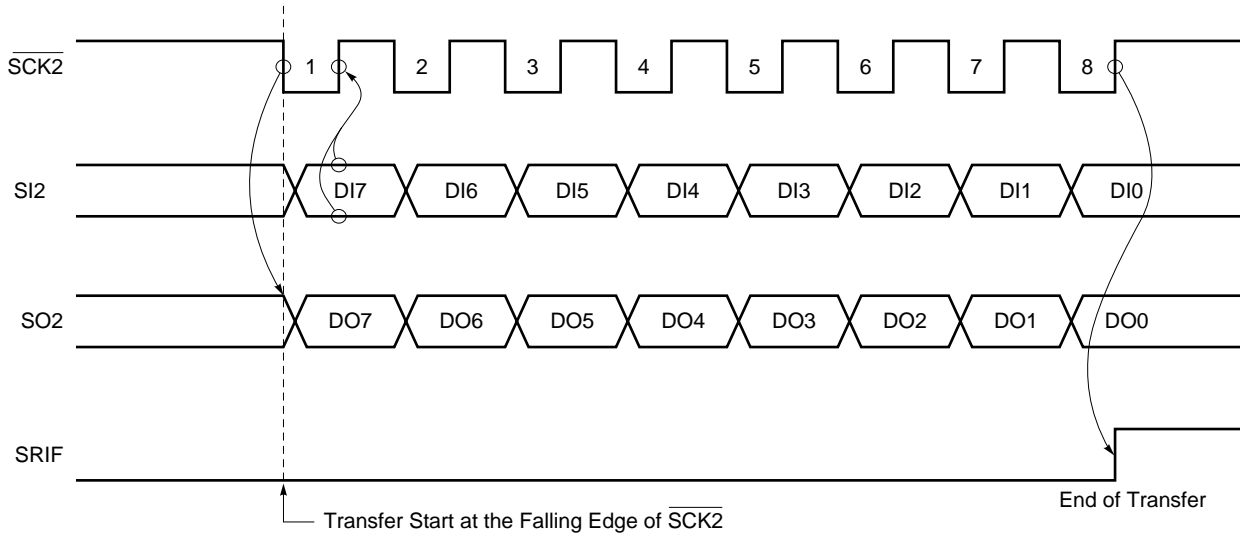
(2) Communication operation

In the 3-wire serial I/O mode, data transmission/reception is performed in 8-bit units. Data is transmitted/received bit by bit in synchronization with the serial clock.

Transmit shift register (TXS/SIO2) and receive shift register (RXS) shift operations are performed in synchronization with the fall of the serial clock $\overline{SCK2}$. Then transmit data is held in the SO2 latch and output from the SO2 pin. Also, receive data input to the SI2 pin is latched in the receive buffer register (RXB/SIO2) on the rise of $\overline{SCK2}$.

At the end of an 8-bit transfer, the operation of the TXS/SIO2 or RXS stops automatically, and the interrupt request flag (SRIF) is set.

Figure 19-12. 3-Wire Serial I/O Mode Timing



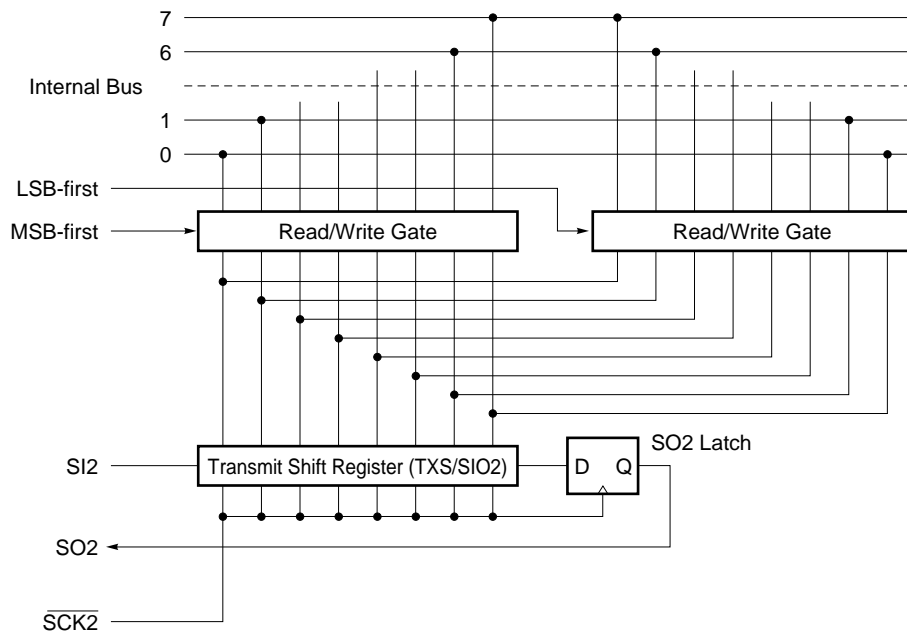
(3) MSB/LSB switching as the start bit

The 3-wire serial I/O mode enables to select transfer to start from MSB or LSB.

Figure 19-13 shows the configuration of the transmit shift register (TXS/SIO2) and internal bus. As shown in the figure, MSB/LSB can be read/written in reverse form.

MSB/LSB switching as the start bit can be specified with bit 2 (CSIM22) of the serial operating mode register 2 (CSIM2).

Figure 19-13. Circuit of Switching in Transfer Bit Order



Start bit switching is realized by switching the bit order for data write to TXS/SIO2. The TXS/SIO2 shift order remains unchanged.

Thus, switching between MSB-first and LSB-first must be performed before writing data to the TXS/SIO2.

(4) Transfer start

Serial transfer is started by setting transfer data to the transmission shift register (TXS/SIO2) when the following two conditions are satisfied.

- Serial interface channel 2 operation control bit (CSIE2) = 1
- Internal serial clock is stopped or $\overline{\text{SCK2}}$ is a high level after 8-bit serial transfer.

Caution If CSIE2 is set to "1" after data write to TXS/SIO2, transfer does not start.

Upon termination of 8-bit transfer, serial transfer automatically stops and the interrupt request flag (SRIF) is set.

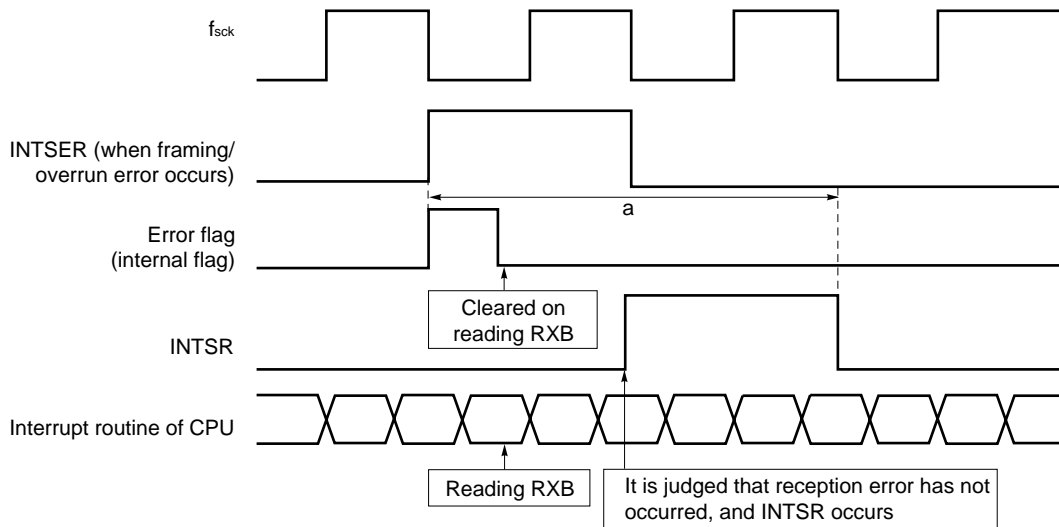
★ 19.4.4 Limitations when UART mode is used

In the UART mode, the reception completion interrupt request (INTSR) occurs a certain time after the reception error interrupt request (INTSER) has occurred and then cleared. Consequently, the following phenomenon may occur.

● Description

If bit 1 (ISRM) of the asynchronous serial interface mode register (ASIM) is set to 1, the reception completion interrupt request (INTSR) does not occur on occurrence of a reception error. If the receive buffer register (RXB) is read at certain timing (a in Figure 19-14) during the reception error interrupt (INTSER) processing, the internal error flag is cleared to 0. As a result, it is judged that no reception error has occurred, and INTSR, which must not occur, occurs. Figure 19-14 illustrates this operation.

Figure 19-14. Reception Completion Interrupt Request Generation Timing (when ISRM = 1)



Remark ISRM : Bit 1 of asynchronous serial interface mode register (ASIM)
 f_{sck} : Source clock of 5-bit counter of baud rate generator
 RXB : Receive buffer register

To avoid this phenomenon, take the following measures:

● Countermeasures

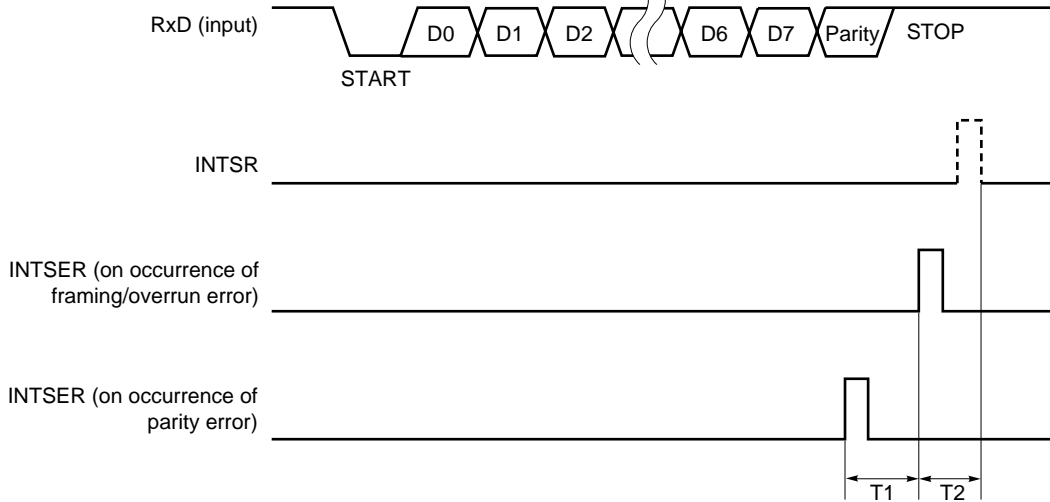
• In case of framing error or overrun error

Disable the receive buffer register (RXB) from being read for a certain time (T₂ in Figure 19-15) after the reception error interrupt request (INTSER) has occurred.

- **In case of parity error**

Disable the receive buffer register (RXB) from being read for a certain time (T1 + T2 in Figure 19-15) after the reception error interrupt request (INTSER) has occurred.

Figure 19-15. Receive Buffer Register Read Disable Period



T1 : Time of one data of baud rate selected by baud rate generator control register (BRGC) (1/baud rate)

T2 : Time of 2 clocks of source clock (f_{sck}) of 5-bit counter selected by BRGC

- **Example of preventive measures**

Here is an example of the above preventive measures.

[Condition]

$f_x = 5.0 \text{ MHz}$

Processor clock control register (PCC) = 00H

Oscillation mode select register (OSMS) = 01H

Baud rate generator control register (BRGC) = B0H (2400 bps selected as baud rate)

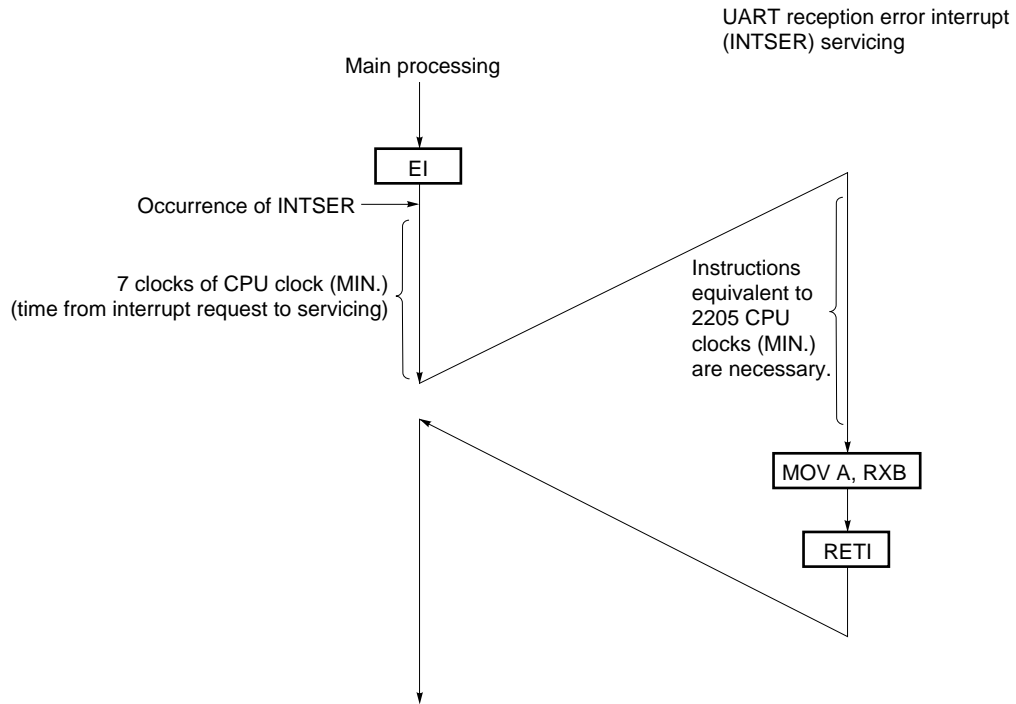
$T_{CY} = 0.4 \mu\text{s}$ ($t_{CY} = 0.2 \mu\text{s}$)

$$T1 = \frac{1}{2400} = 416.7 \mu\text{s}$$

$$T2 = 12.8 \times 2 = 25.6 \mu\text{s}$$

$$\frac{T1 + T2}{t_{CY}} = 2212 \text{ (clocks)}$$

[Example]



CHAPTER 20 REAL-TIME OUTPUT PORT

20.1 Real-Time Output Port Functions

Data set previously in the real-time output buffer register can be transferred to the output latch by hardware concurrently with timer interrupt requests or external interrupt request generation, then output externally. This is called the real-time output function. The pins that output data externally are called real-time output ports.

By using a real-time output, a signal which has no jitter can be output. This port is therefore suitable for control of stepping motors, etc.

Port mode/real-time output port mode can be specified bit-wise.

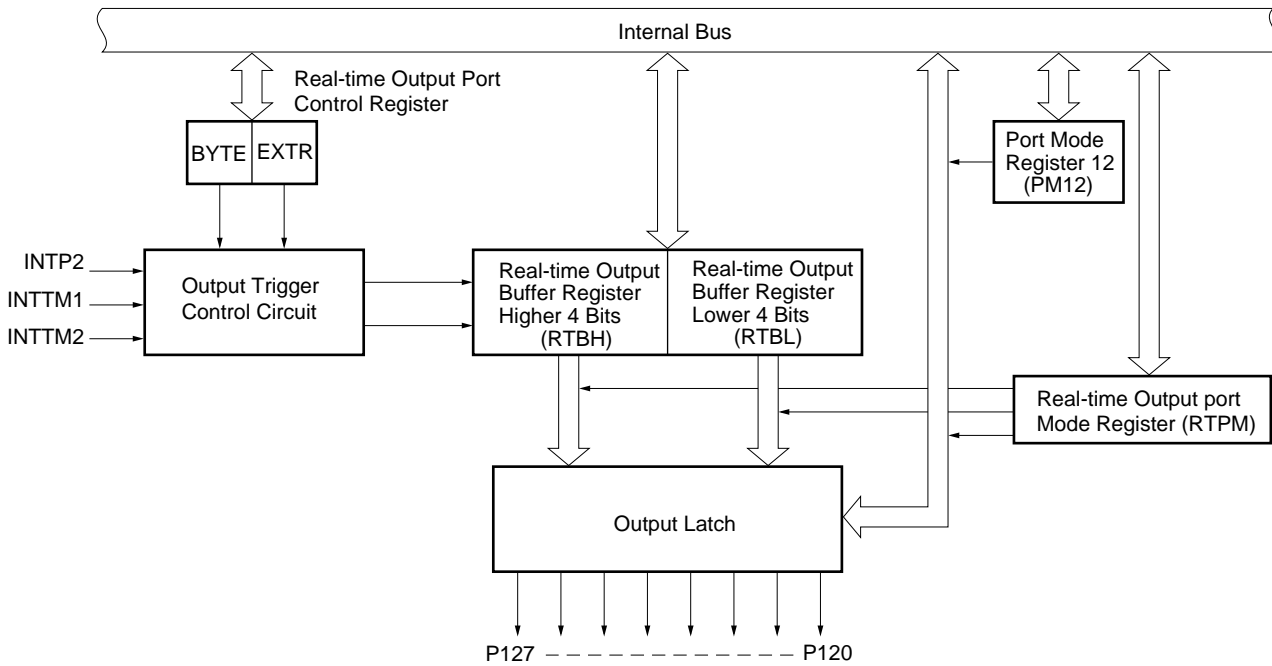
20.2 Real-Time Output Port Configuration

The real-time output port consists of the following hardware.

Table 20-1. Real-time Output Port Configuration

Item	Configuration
Register	Real-time output buffer register (RTBL, RTBH)
Control register	Port mode register 12 (PM12) Real-time output port mode register (RTPM) Real-time output port control register (RTPC)

Figure 20-1. Real-time Output Port Block Diagram



(1) Real-time output buffer register (RTBL, RTBH)

Addresses of RTBL and RTBH are mapped individually in the Special function register (SFR) area as shown in Figure 20-2.

When specifying 4 bits × 2 channels as the operating mode, data are set individually in RTBL and RTBH. When specifying 8 bits × 1 channel as the operating mode, data are set to both RTBL and RTBH by writing 8-bit data to either RTBL or RTBH.

Table 20-2 shows operations during manipulation of RTBL and RTBH.

Figure 20-2. Real-time Output Buffer Register Configuration

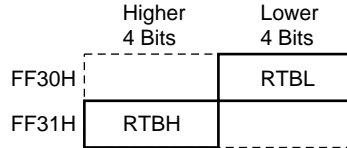


Table 20-2. Operation in Real-time Output Buffer Register Manipulation

Operating Mode	Register to be Manipulated	In Read ^{Note1}		In Write ^{Note2}	
		Higher 4 Bits	Lower 4 Bits	Higher 4 Bits	Lower 4 Bits
4 Bits × 2 Channels	RTBL	RTBH	RTBL	Invalid	RTBL
	RTBH	RTBH	RTBL	RTBH	Invalid
8 Bits × 1 Channel	RTBL	RTBH	RTBL	RTBH	RTBL
	RTBH	RTBH	RTBL	RTBH	RTBL

- Notes**
1. Only the bits set in the real-time output port mode can be read. When a bit set in the port mode is read, 0 is read.
 2. After setting data in the real-time output port, output data should be set in RTBL and RTBH by the time a real-time output trigger is generated.

20.3 Real-Time Output Port Control Registers

The following three registers control the real-time output port.

- Port mode register 12 (PM12)
- Real-time output port mode register (RTPM)
- Real-time output port control register (RTPC)

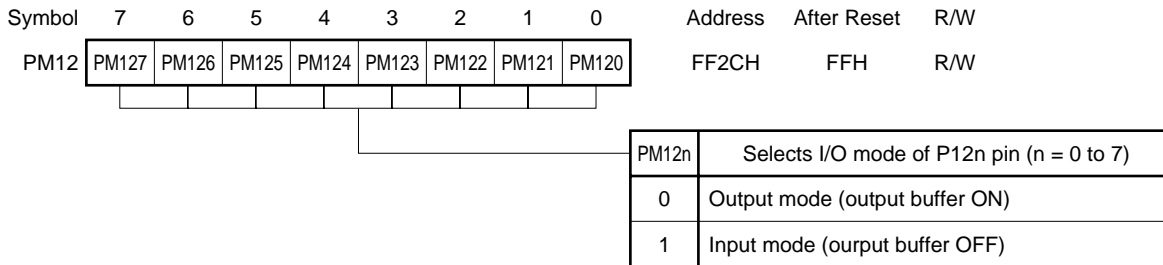
(1) Port mode register 12 (PM12)

This register sets the input or output mode of port 12 pins (P120 through P127) which are multiplexed with real-time output pins (RTP0 through RTP7). To use port 12 as a real-time output port, the port pin that performs real-time output must be set in the output mode (PM12n = 0: n = 0 to 7).

PM12 is set by using a 1-bit or 8-bit memory manipulation instruction.

This register is set to FFH by RESET input.

Figure 20-3. Port Mode Register 12 Format



(2) Real-time output port mode register (RTPM)

This register selects the real-time output port mode/port mode bit-wise.

RTPM is set with a 1-bit or 8-bit memory manipulation instruction.

RESET input sets this register to 00H.

Figure 20-4. Real-time Output Port Mode Register Format



- Cautions**
1. When using these bits as a real-time output port, set the ports to which real-time output is performed to the output mode (clear the corresponding bit of the port mode register 12 (PM12) to 0).
 2. In the port specified as a real-time output port, data cannot be set to the output latch. Therefore, when setting an initial value, data should be set to the output latch before setting the real-time output mode.

(3) Real-time output port control register (RTPC)

This register sets the real-time output port operating mode and output trigger.

Table 20-3 shows the relation between the operating mode of the real-time output port and output trigger.

RTPC is set with a 1-bit or 8-bit memory manipulation instruction.

RESET input sets this register to 00H.

Figure 20-5. Real-time Output Port Control Register Format

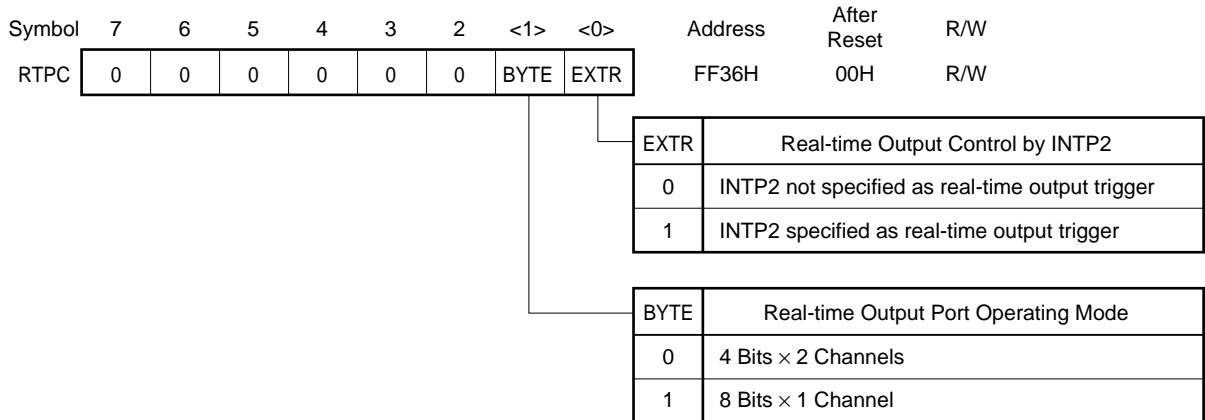


Table 20-3. Real-time Output Port Operating Mode and Output Trigger

BYTE	EXTR	Operating Mode	RTBH → Port Output	RTBL → Port Output
0	0	4 Bits × 2 Channels	INTTM2	INTTM1
	1		INTTM1	INTP2
1	0	8 Bits × 1 Channel	INTTM1	
	1		INTP2	

[MEMO]

CHAPTER 21 INTERRUPT AND TEST FUNCTIONS

21.1 Interrupt Function Types

The following three types of interrupt functions are used.

(1) Non-maskable interrupt

This interrupt is acknowledged unconditionally even in the interrupt disabled status. It does not undergo interrupt priority control and is given top priority over all other interrupt requests.

It generates a standby release signal.

Non-maskable interrupt includes one interrupt request source from watchdog timer.

(2) Maskable interrupts

These interrupts undergo mask control. Maskable interrupts can be divided into a high interrupt priority group and a low interrupt priority group by setting the priority specify flag register (PR0L, PR0H, PR1L).

Multiple high priority interrupts can be applied to low priority interrupts. If two or more interrupts with the same priority are simultaneously generated, each interrupt has a predetermined priority (see **Table 21-1**).

A standby release signal is generated.

Maskable interrupt includes 7 external interrupt request sources and 13 internal interrupt request sources.

(3) Software interrupt

This is a vectored interrupt that occurs when the BRK instruction is executed. It is acknowledged even in a disabled state. The software interrupt does not undergo interrupt priority control.

21.2 Interrupt Sources and Configuration

Interrupt sources includes total of 22 non-maskable, maskable, software interrupts (refer to **Table 21-1**).

Table 21-1. Interrupt Source List (1/2)

Interrupt Type	Note 1 Default Priority	Interrupt Source		Internal/ External	Vector Table Address	Note 2 Basic Configuration Type
		Name	Trigger			
Non-maskable	–	INTWDT	Watchdog timer overflow (with watchdog timer mode 1 selected)	Internal	0004H	(A)
	0	INTWDT	Watchdog timer overflow (with interval timer mode selected)			(B)
Maskable	1	INTP0	Pin input edge detection	External	0006H	(C)
	2	INTP1			0008H	(D)
	3	INTP2			000AH	
	4	INTP3			000CH	
	5	INTP4			000EH	
	6	INTP5			0010H	
	7	INTP6			0012H	
	8	INTCSI0			End of serial interface channel 0 transfer	Internal
	9	INTCSI1	End of serial interface channel 1 transfer	0016H		
	10	INTSER	Serial interface channel 2 UART reception error generation	0018H		
	11	INTSR	End of serial interface channel 2 UART reception	001AH		
		INTCSI2	End of serial interface channel 2 3-wire transfer			
12	INTST	End of serial interface channel 2 UART transfer	001CH			

Notes 1. Default priorities are intended for two or more simultaneously generated maskable interrupt requests. 0 is the highest priority and 20 is the lowest priority.

2. Basic configuration types (A) to (E) correspond to (A) to (E) of Figure 21-1.

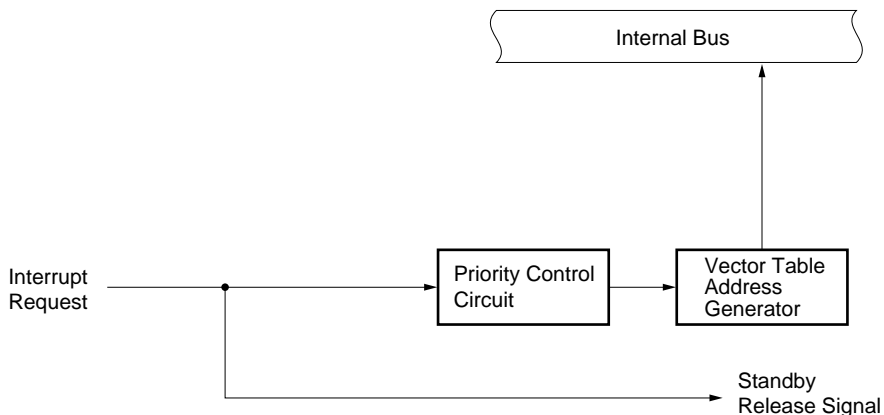
Table 21-1. Interrupt Source List (2/2)

Interrupt Type	Note 1 Default Priority	Interrupt Source		Internal/ External	Vector Table Address	Note 2 Basic Configuration Type
		Name	Trigger			
Maskable	13	INTTM3	Reference time interval signal from watch timer	Internal	001EH	(B)
	14	INTTM00	Generation of 16-bit timer register, capture/compare register (CR00) match signal		0020H	
	15	INTTM01	Generation of 16-bit timer register, capture/compare register (CR01) match signal		0022H	
	16	INTTM1	Generation of 8-bit timer/event counter 1 match signal		0024H	
	17	INTTM2	Generation of 8 bit timer/event counter 2 match signal		0026H	
	18	INTAD	End of A/D converter conversion		0028H	
Software	—	BRK	BRK instruction execution	—	003EH	(E)

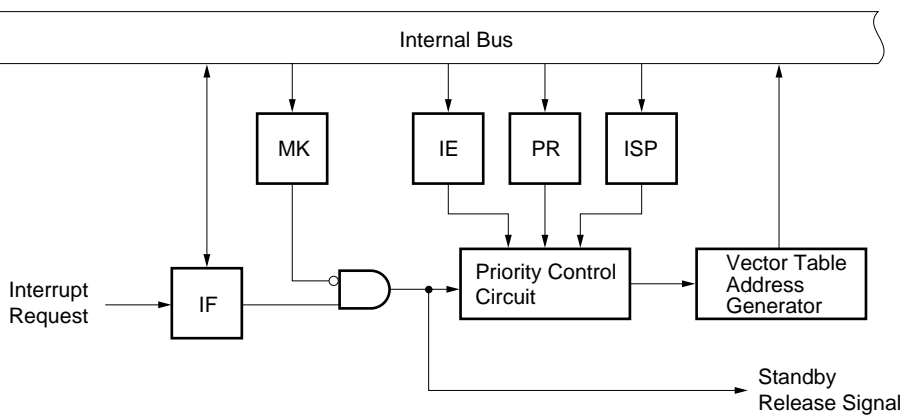
- Notes**
1. Default priorities are intended for two or more simultaneously generated maskable interrupt requests. 0 is the highest priority and 18 is the lowest priority.
 2. Basic configuration types (A) to (E) correspond to (A) to (E) of Figure 21-1.

Figure 21-1. Basic Configuration of Interrupt Function (1/2)

(A) Internal non-maskable interrupt



(B) Internal maskable interrupt



(C) External maskable interrupt (INTP0)

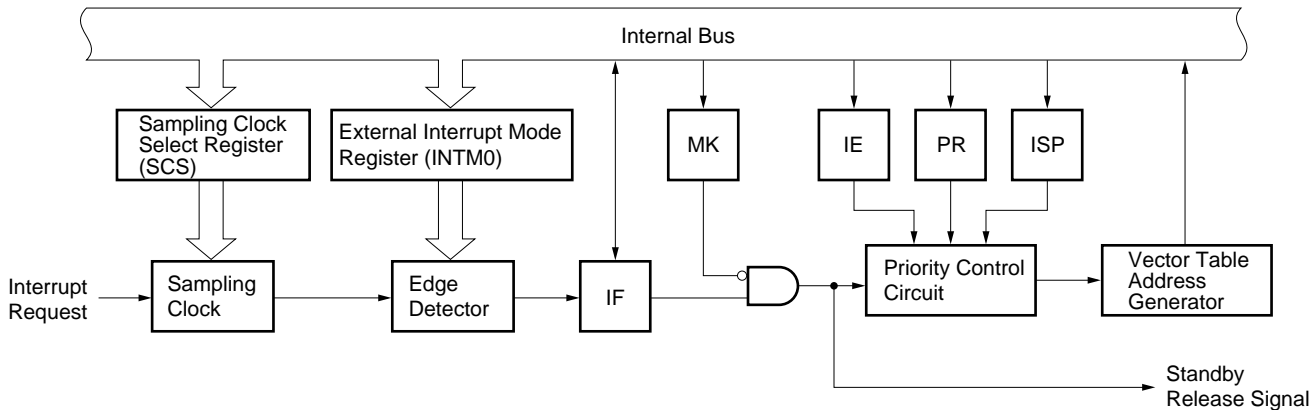
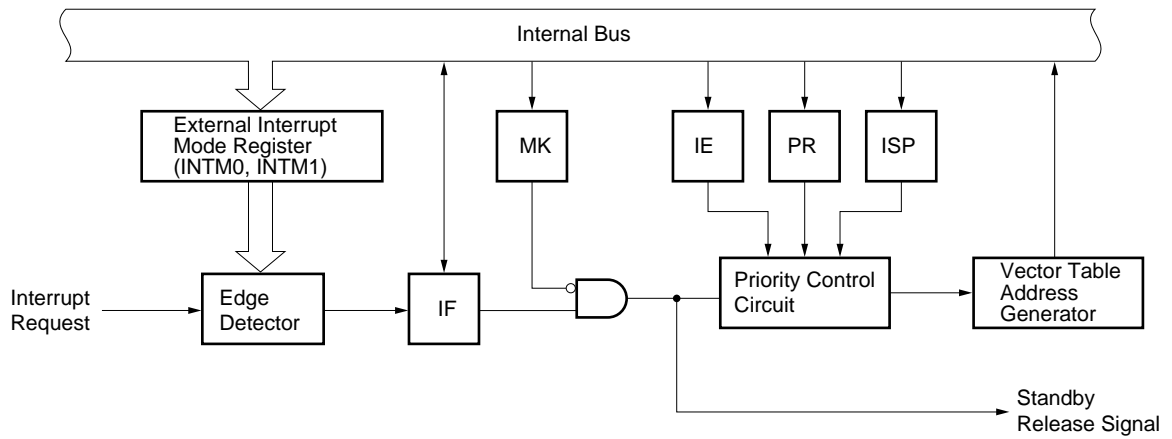
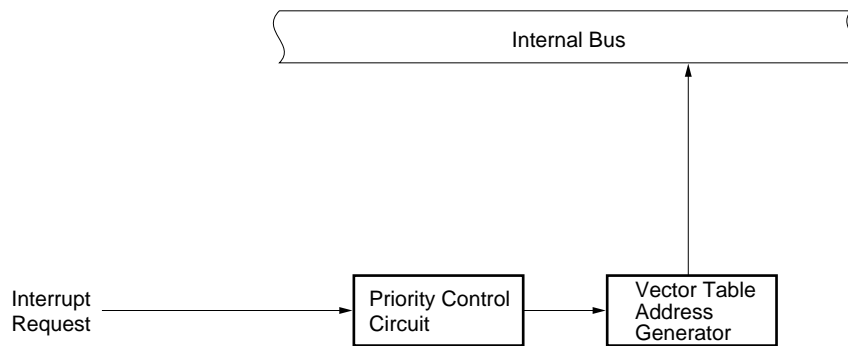


Figure 21-1. Basic Configuration of Interrupt Function (2/2)

(D) External maskable interrupt (except INTP0)



(E) Software interrupt



- Remark**
- IF : Interrupt request flag
 - IE : Interrupt enable flag
 - ISP : Inservice priority flag
 - MK : Interrupt mask flag
 - PR : Priority specify flag

21.3 Interrupt Function Control Registers

The following six types of registers are used to control the interrupt functions.

- Interrupt request flag register (IF0L, IF0H, IF1L)
- Interrupt mask flag register (MK0L, MK0H, MK1L)
- Priority specify flag register (PR0L, PR0H, PR1L)
- External interrupt mode register (INTM0, INTM1)
- Sampling clock select register (SCS)
- Program status word (PSW)

Table 21-2 gives a listing of interrupt request flags, interrupt mask flags, and priority specify flags corresponding to interrupt request sources.

Table 21-2. Various Flags Corresponding to Interrupt Request Sources

Interrupt Source	Interrupt Request Flag		Interrupt Mask Flag		Priority Specify Flag	
		Register		Register		Register
INTWDT	TMIF4	IF0L	TMMK4	MK0L	TMPR4	PR0L
INTP0	PIF0		PMK0		PPR0	
INTP1	PIF1		PMK1		PPR1	
INTP2	PIF2		PMK2		PPR2	
INTP3	PIF3		PMK3		PPR3	
INTP4	PIF4		PMK4		PPR4	
INTP5	PIF5		PMK5		PPR5	
INTP6	PIF6	PMK6	PPR6			
INTCSI0	CSIIF0	IF0H	CSIMK0	MK0H	CSIPR0	PR0H
INTCSI1	CSIIF1		CSIMK1		CSIPR1	
INTSER	SERIF		SERMK		SERPR	
INTSR/INTCSI2	SRIF		SRMK		SRPR	
INTST	STIF		STMK		STPR	
INTTM3	TMIF3		TMMK3		TMPR3	
INTTM00	TMIF00		TMMK00		TMPR00	
INTTM01	TMIF01		TMMK01		TMPR01	
INTTM1	TMIF1	IF1L	TMMK1	MK1L	TMPR1	PR1L
INTTM2	TMIF2		TMMK2		TMPR2	
INTAD	ADIF		ADMK		ADPR	

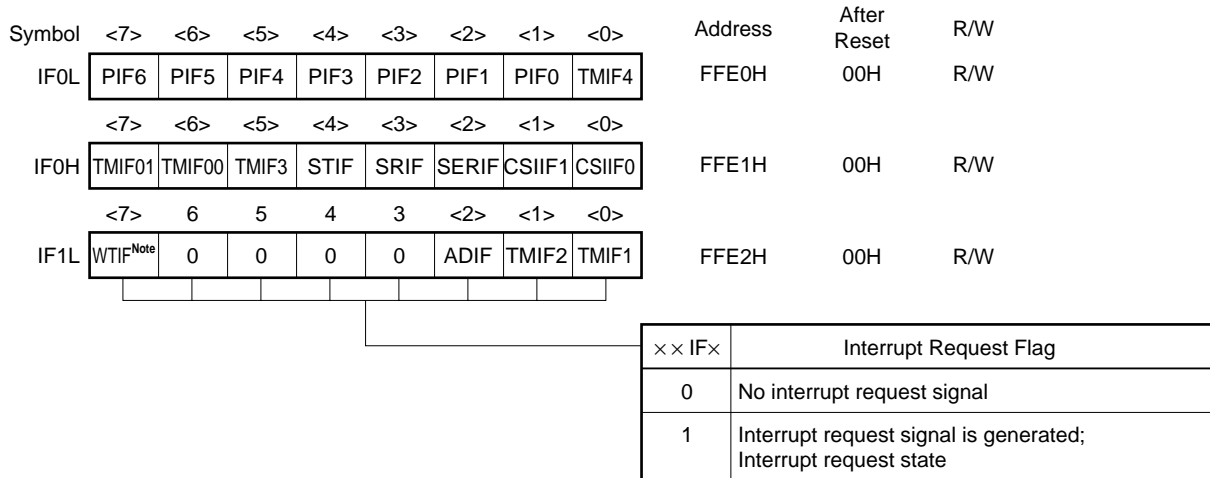
(1) Interrupt request flag registers (IF0L, IF0H, IF1L)

The interrupt request flag is set to 1 when the corresponding interrupt request is generated or an instruction is executed. It is cleared to 0 when an instruction is executed upon acknowledgment of an interrupt request or upon application of $\overline{\text{RESET}}$ input.

IF0L, IF0H, and IF1L are set with a 1-bit or 8-bit memory manipulation instruction. If IF0L and IF0H are used as a 16-bit register IF0 use a 16-bit memory manipulation instruction for the setting.

$\overline{\text{RESET}}$ input sets these registers to 00H.

Figure 21-2. Interrupt Request Flag Register Format



Note WTIF is test input flag. Vectored interrupt request is not generated.

- Cautions**
1. TMIF4 flag is R/W enabled only when a watchdog timer is used as an interval timer mode. If a watchdog timer is used in watchdog timer mode 1, set TMIF4 flag to 0.
 2. Set always 0 in IF1L bits 3 through 6.

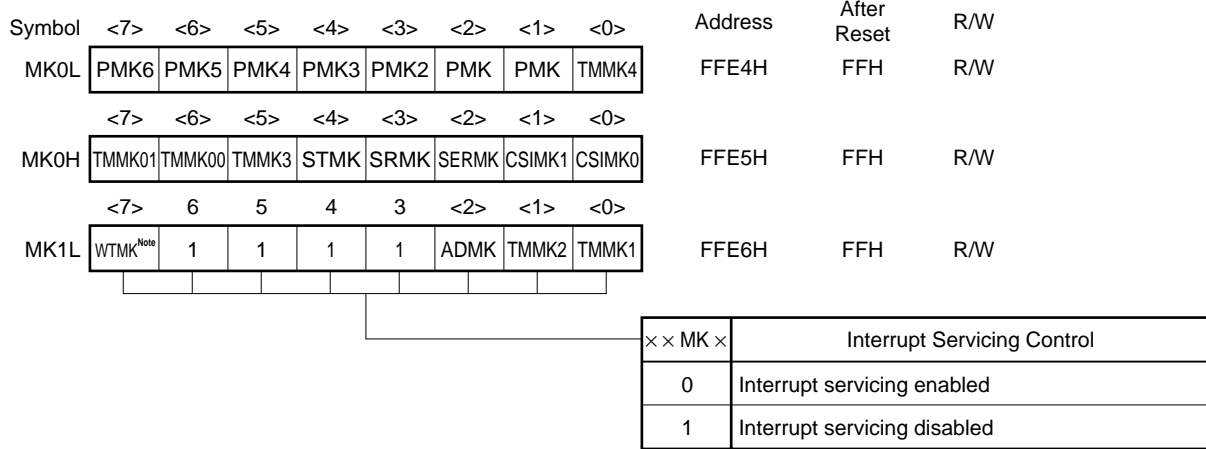
(2) Interrupt mask flag registers (MK0L, MK0H, MK1L)

The interrupt mask flag is used to enable/disable the corresponding maskable interrupt service and to set standby clear enable/disable.

MK0L, MK0H, and MK1L are set with a 1-bit or 8-bit memory manipulation instruction. If MK0L and MK0H are used as a 16-bit register MK0, use a 16-bit memory manipulation instruction for the setting.

$\overline{\text{RESET}}$ input sets these registers to FFH.

Figure 21-3. Interrupt Mask Flag Register Format



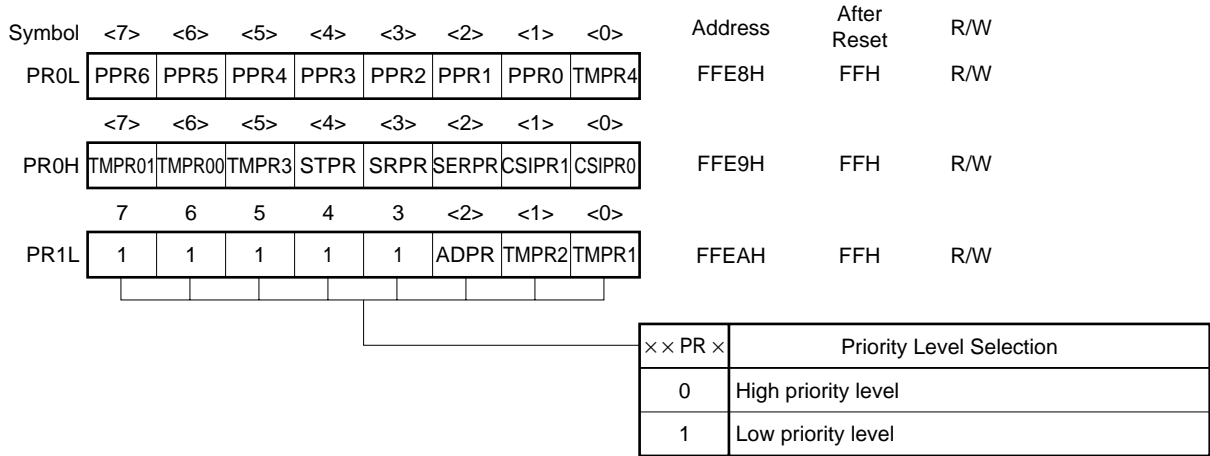
Note WTMK controls standby mode release enable/disable. It does not perform control of interrupt function.

- Cautions**
1. If TMMK4 flag is read when a watchdog timer is used in watchdog timer mode 1, MK0 value becomes undefined.
 2. Because port 0 has a dual function as the external interrupt request input, when the output level is changed by specifying the output mode of the port function, an interrupt request flag is set. Therefore, 1 should be set in the interrupt mask flag before using the output mode.
 3. Set always 1 in MK1L bits 3 through 6.

(3) Priority specify flag registers (PR0L, PR0H, and PR1L)

The priority specify flag is used to set the corresponding maskable interrupt priority orders. PR0L, PR0H, and PR1L are set with a 1-bit or 8-bit memory manipulation instruction. If PR0L and PR0H are used as a 16-bit register PR0, use a 16-bit memory manipulation instruction for the setting. RESET input sets these registers to FFH.

Figure 21-4. Priority Specify Flag Register Format



- Cautions**
1. If a watchdog timer is used in watchdog timer mode 1, set TMPR4 flag to 1.
 2. Set always 1 in PR1L bits 3 through 7.

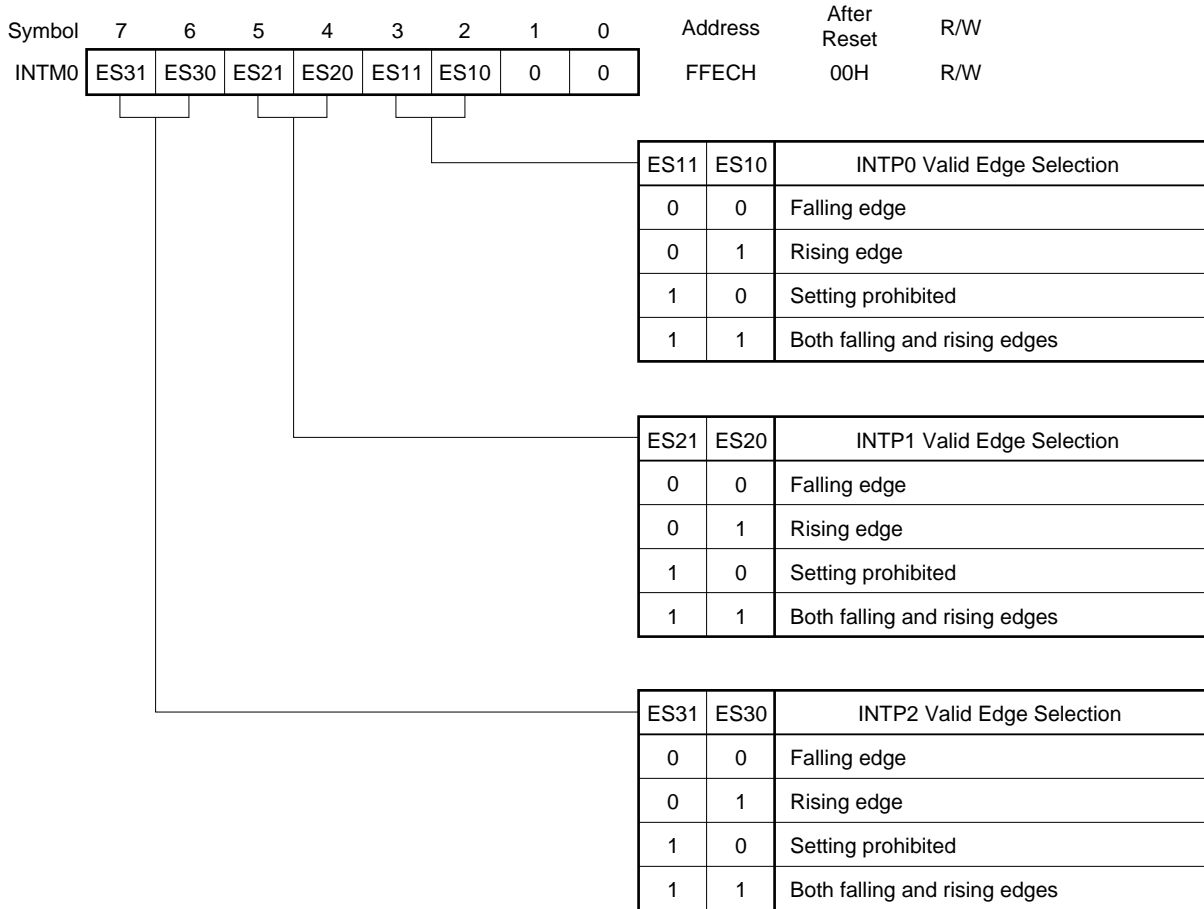
(4) External interrupt mode register (INTM0, INTM1)

These registers set the valid edge for INTP0 to INTP6.

INTM0 and INTM1 are set by 8-bit memory manipulation instructions.

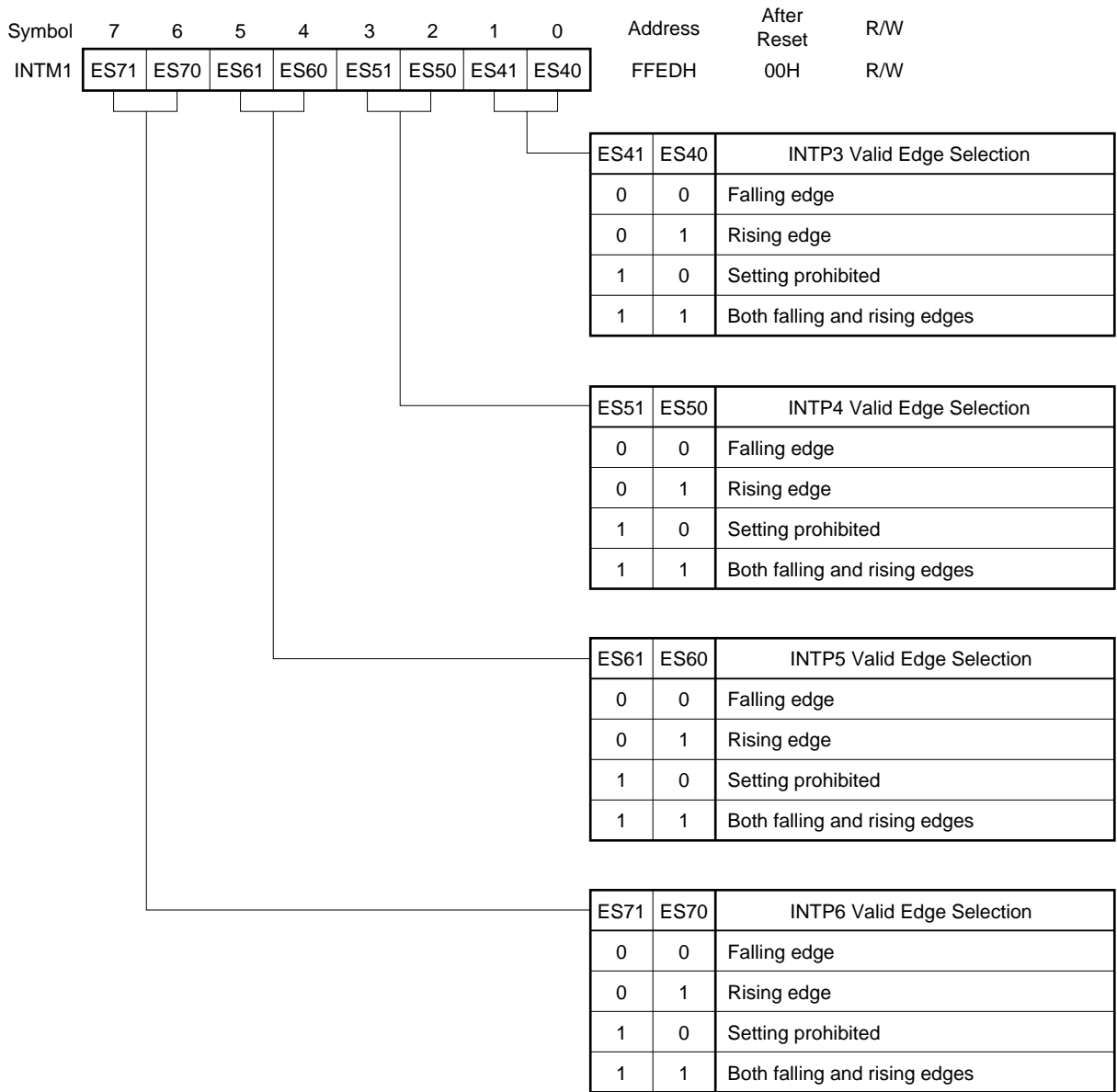
$\overline{\text{RESET}}$ input sets these registers to 00H.

Figure 21-5. External Interrupt Mode Register 0 Format



Caution Before setting the valid edge of the INTP0/TIO0/P00 pin, stop the timer operation by clearing the bits 1 through 3 (TMC01 through TMC03) of the 16-bit timer mode control register to 0, 0, 0.

Figure 21-6. External Interrupt Mode Register 1 Format



(5) Sampling clock select register (SCS)

This register is used to set the valid edge clock sampling clock to be input to INTP0. When remote controlled data reception is carried out using INTP0, digital noise is removed with sampling clocks.

SCS is set with an 8-bit memory manipulation instruction.

RESET input sets SCS to 00H.

Figure 21-7. Sampling Clock Select Register Format



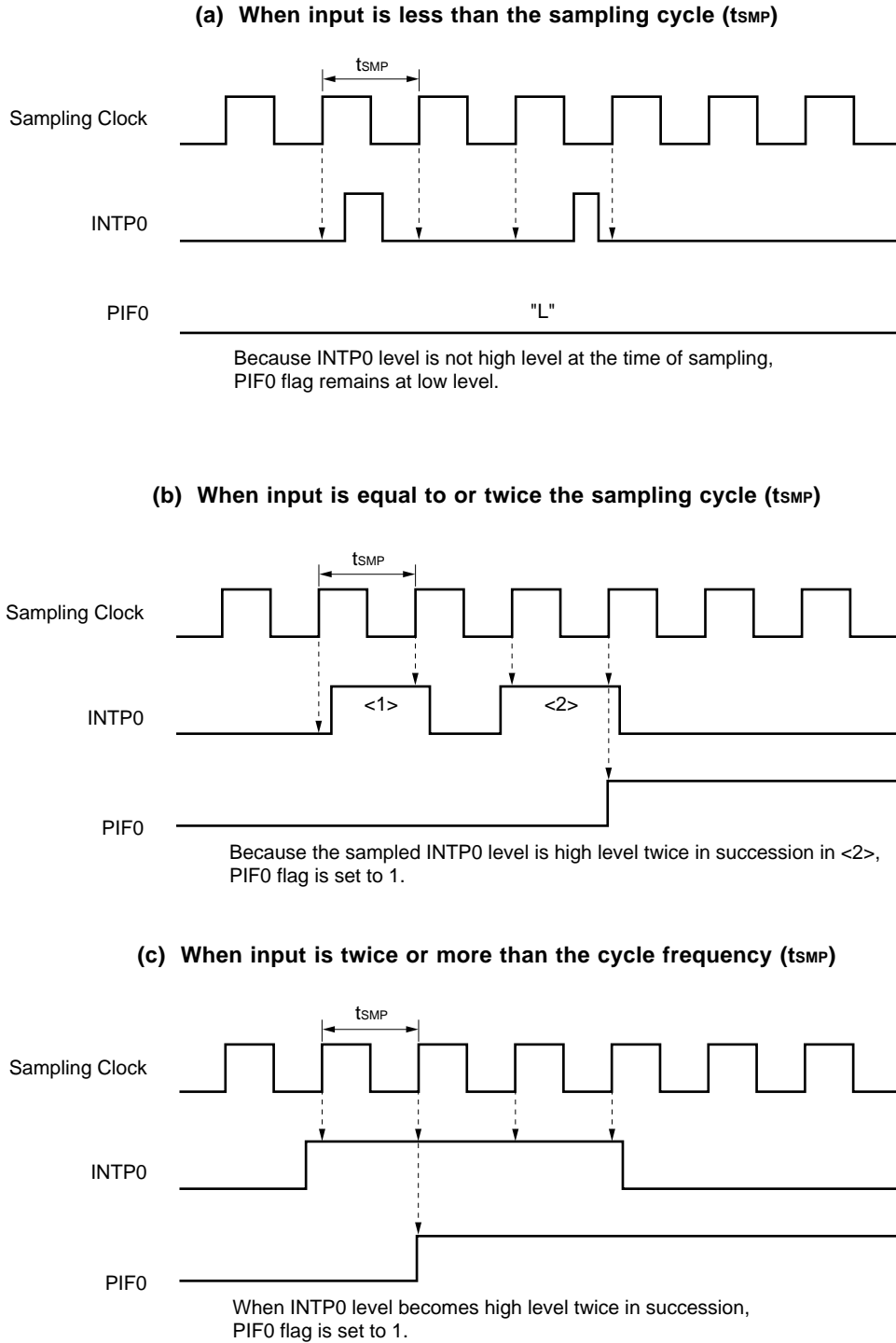
Caution $f_{xx}/2^N$ is a clock to be supplied to the CPU and $f_{xx}/2^5$, $f_{xx}/2^6$ and $f_{xx}/2^7$ are clocks to be supplied to the peripheral hardware. $f_{xx}/2^N$ stops in the HALT mode.

- Remarks**
1. N : Value (N=0 to 4) at bits 0 to 2 (PCC0 to PCC2) of processor clock control register (PCC)
 2. f_{xx} : Main system clock frequency (f_x or $f_x/2$)
 3. f_x : Main system clock oscillation frequency
 4. MCS : Oscillation mode selection register (OSMS) bit 0
 5. Values in parentheses when operated with $f_x = 5.0$ MHz.

When the sampled INTP0 input level is active twice in succession, the noise eliminator sets interrupt request flag (PIF0) to 1.

Figure 21-8 shows the noise eliminator input/output timing.

Figure 21-8. Noise Eliminator Input/Output Timing (during rising edge detection)



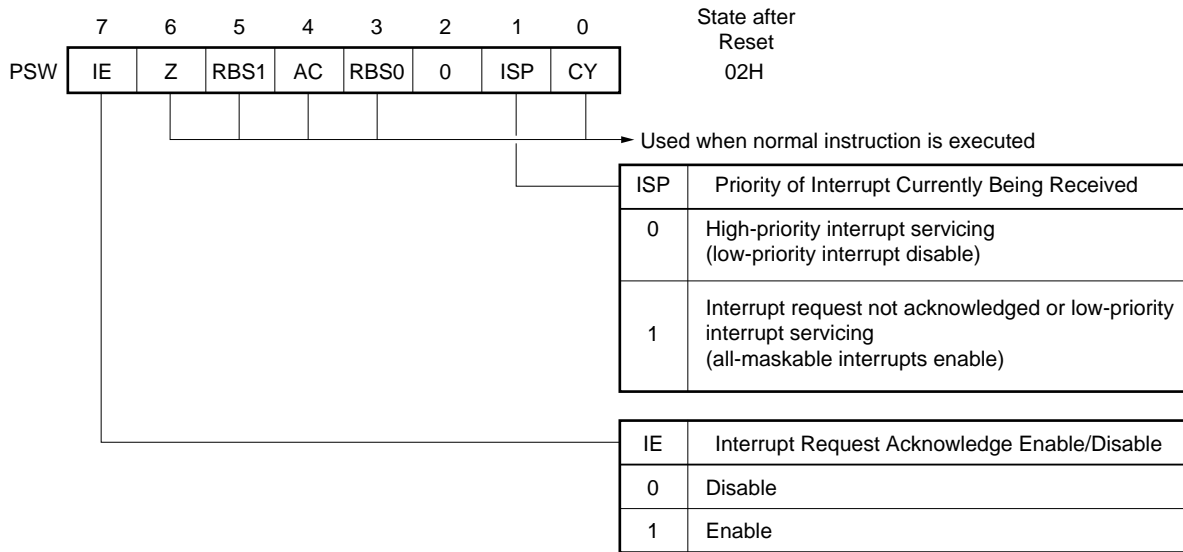
(6) Program status word (PSW)

The program status word is a register to hold the instruction execution result and the current status for interrupt request. The IE flag to set maskable interrupt enable/disable and the ISP flag to control multiple interrupt processing are mapped.

Besides 8-bit unit read/write, this register can carry out operations with a bit manipulation instruction and dedicated instructions (EI and DI). When a vectored interrupt request is acknowledged or when the BRK instruction is executed, contents of the PSW is automatically saved to the stack and the IE flag is reset to 0. If a maskable interrupt request is acknowledged contents of the priority specify flag of the acknowledged interrupt are transferred to the ISP flag. Contents of the PSW is also saved into the stack with the PUSH PSW instruction. It is reset from the stack with the RETI, RETB, and POP PSW instructions.

$\overline{\text{RESET}}$ input sets PSW to 02H.

Figure 21-9. Program Status Word Configuration



21.4 Interrupt Servicing Operations

21.4.1 Non-maskable interrupt request acknowledge operation

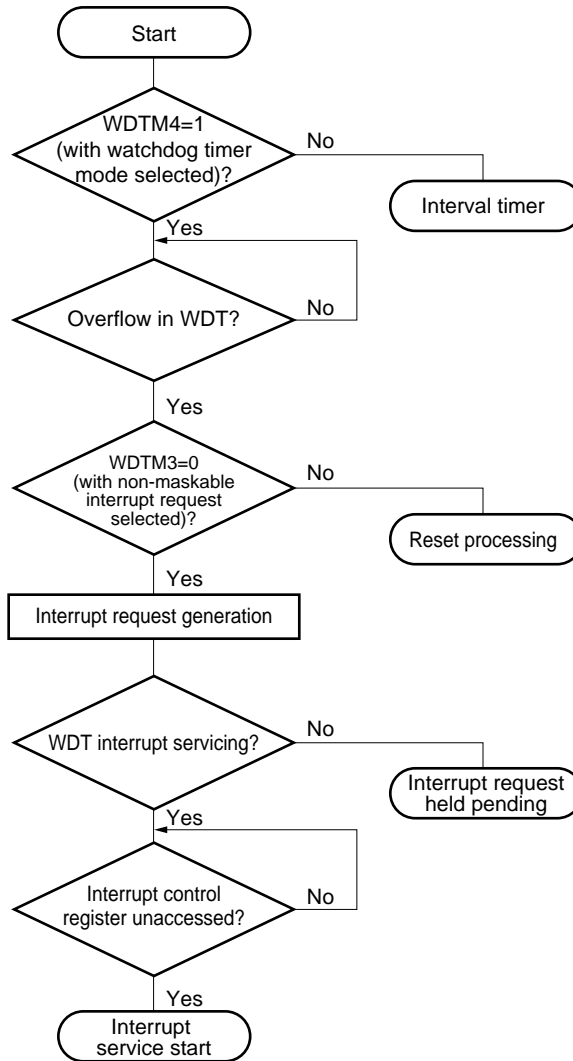
A non-maskable interrupt request is unconditionally acknowledged even if in an interrupt request acknowledge disable state. It does not undergo interrupt priority control and has highest priority over all other interrupt requests.

If a non-maskable interrupt request is acknowledged, the contents of acknowledged interrupt is saved in the stacks, program status word (PSW) and program counter (PC), in that order, the IE and ISP flags are reset to 0, and the vector table contents are loaded into PC and branched.

A new non-maskable interrupt request generated during execution of a non-maskable interrupt servicing program is acknowledged after the current execution of the non-maskable interrupt servicing program is terminated (following RETI instruction execution) and one main routine instruction is executed. If a new non-maskable interrupt request is generated twice or more during non-maskable interrupt service program execution, only one non-maskable interrupt request is acknowledged after termination of the non-maskable interrupt service program execution.

Figure 21-10 shows the flowchart from generation of non-maskable interrupt request to acknowledgment, Figure 21-11 shows non-maskable interrupt request acknowledge timing, and Figure 21-12 shows acknowledge operation when multiple non-maskable interrupt requests are generated.

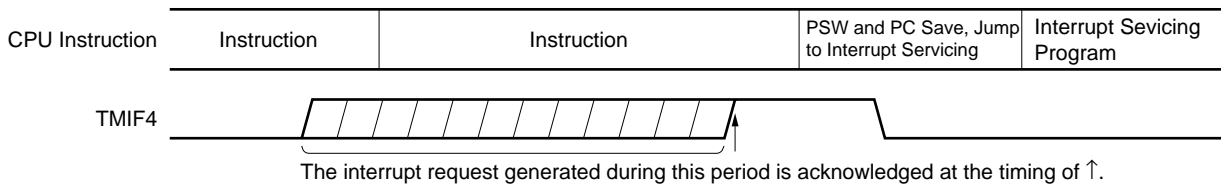
Figure 21-10. Flowchart of Generation from Non-Maskable Interrupt Request to Acknowledgment



WDTM : Watchdog timer mode register

WDT : Watchdog timer

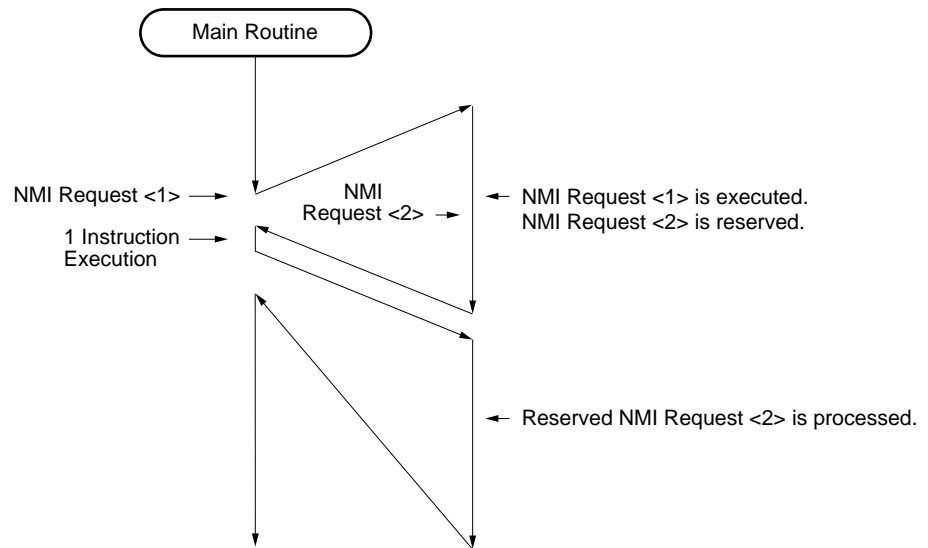
Figure 21-11. Non-Maskable Interrupt Request Acknowledge Timing



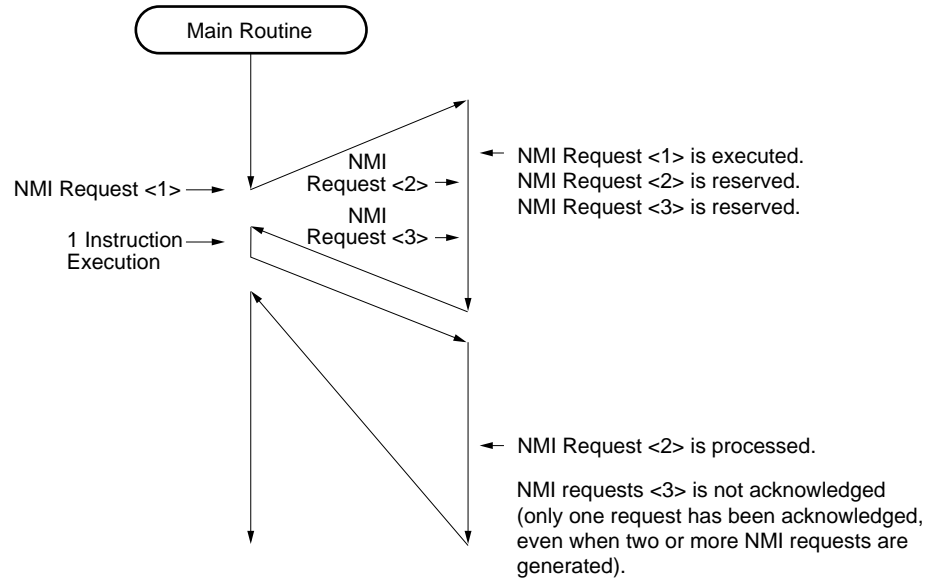
TMIF4 : Watchdog timer interrupt request flag

Figure 21-12. Non-Maskable Interrupt Request Acknowledge Operation

(a) If a new non-maskable interrupt request is generated during non-maskable interrupt servicing program execution



(b) If two non-maskable interrupt requests are generated during non-maskable interrupt servicing program execution



21.4.2 Maskable interrupt request acknowledge operation

A maskable interrupt request becomes acknowledgeable when an interrupt request flag is set to 1 and the interrupt mask flag is cleared to 0. A vectored interrupt request is acknowledged in an interrupt enable state (with IE flag set to 1). However, a low-priority interrupt request is not acknowledged during high-priority interrupt service (with ISP flag reset to 0).

Table 21-3 shows the time from generation of maskable interrupt request to interrupt servicing. For the interrupt request acknowledging timing, refer to **Figure 21-14** and **21-15**.

Table 21-3. Times from Maskable Interrupt Request Generation to Interrupt Service

	Minimum Time	Maximum Time ^{Note}
When $\times\times PR\times=0$	7 clocks	32 clocks
When $\times\times PR\times=1$	8 clocks	33 clocks

Note If an interrupt request is generated just before a divide instruction, the wait time is maximized.

Remark 1 clock : $\frac{1}{f_{CPU}}$ (fCPU: CPU clock)

If two or more maskable interrupt requests are generated simultaneously, the request specified for higher priority with the priority specify flag is acknowledged first. If two or more requests are specified for the same priority with priority specify flag, the interrupt request with higher default priority is acknowledged first.

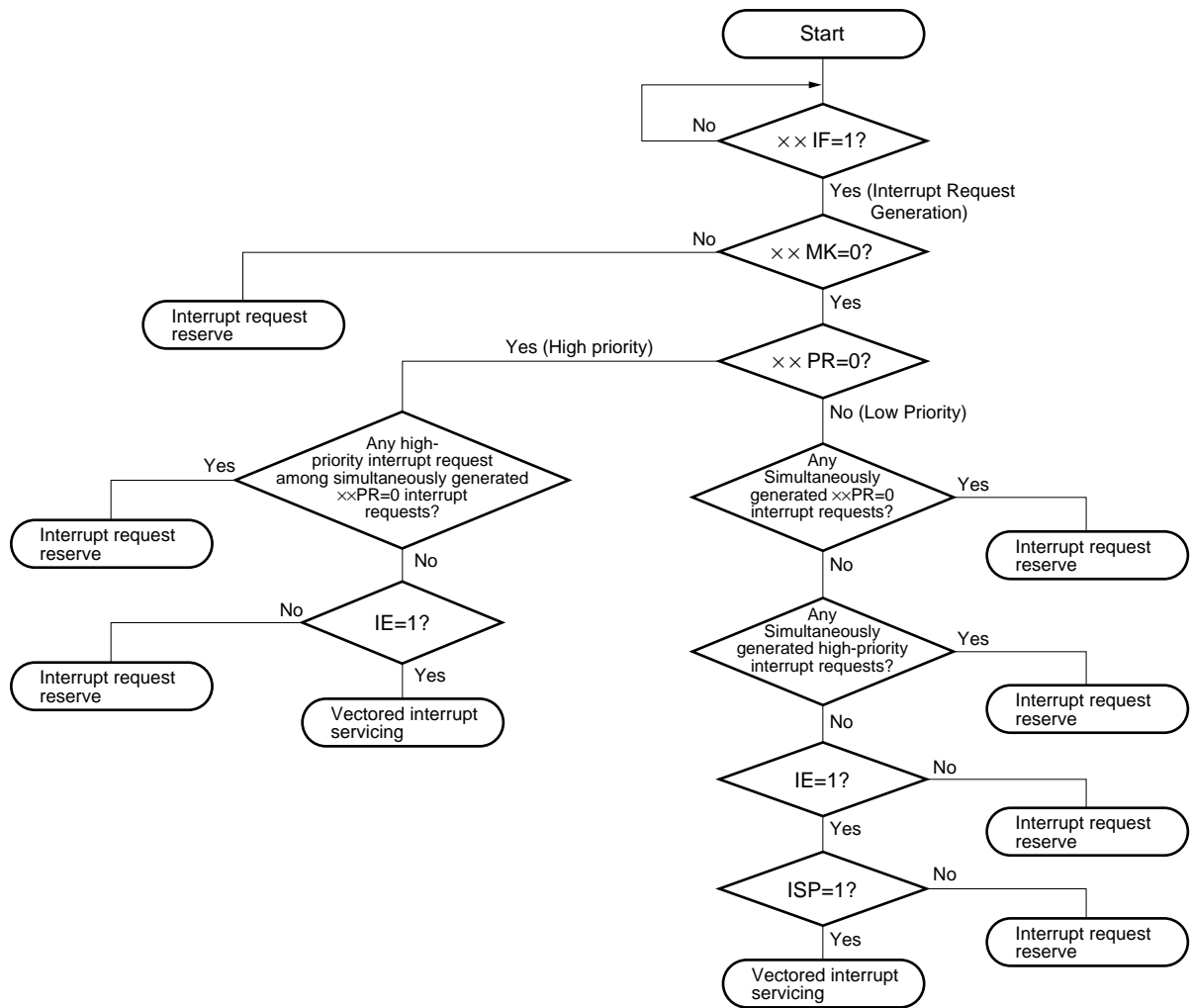
Any reserved interrupt requests are acknowledged when they become acknowledgeable.

Figure 21-13 shows interrupt request acknowledge algorithms.

If a maskable interrupt request is acknowledged, the contents of acknowledged interrupt is saved in the stacks, program status word (PSW) and program counter (PC), in that order, the IE flag is reset to 0, and the acknowledged interrupt priority specify flag contents are transferred to the ISP flag. Further, the vector table data determined for each interrupt request is loaded into PC and branched.

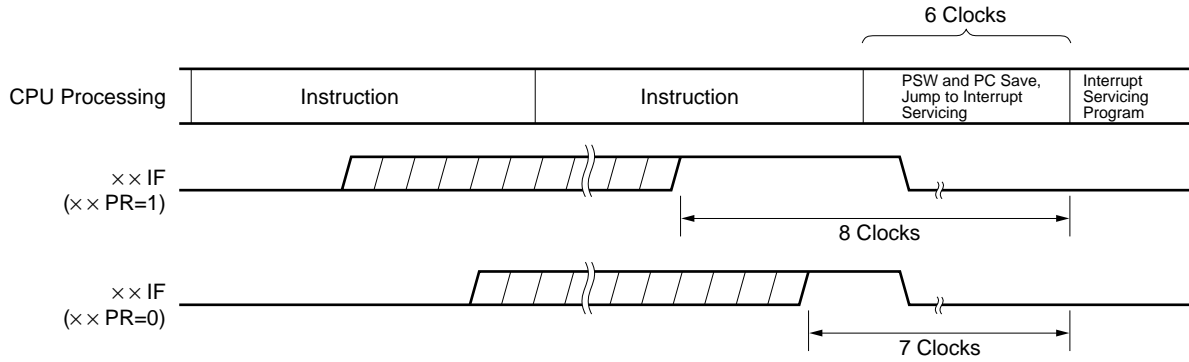
Return from the interrupt is possible with the RETI instruction.

Figure 21-13. Interrupt Request Acknowledge Processing Algorithm



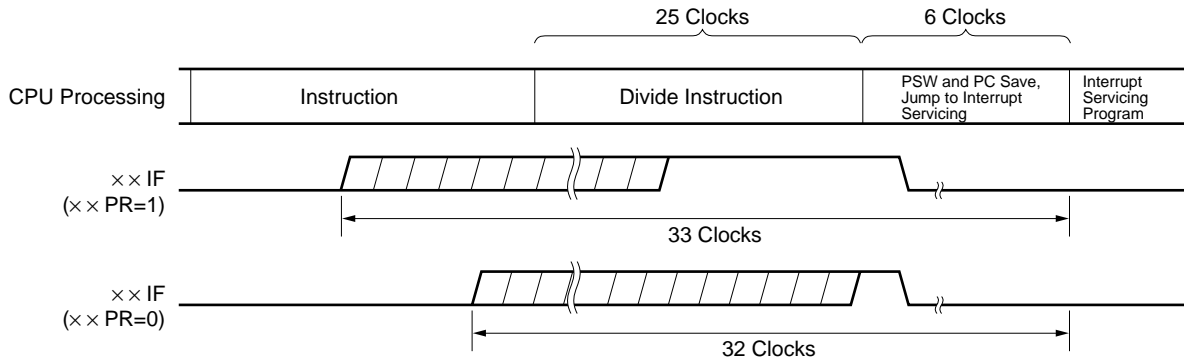
- ××IF : Interrupt request flag
- ××MK : Interrupt mask flag
- ××PR : Priority specify flag
- IE : Flag to control acknowledgment of maskable interrupt request (1 = enable, 0 = disable)
- ISP : Flag to indicate the priority of interrupt currently being serviced (0 = servicing interrupt of high priority, 1 = not acknowledging interrupt request or servicing interrupt of low priority)

Figure 21-14. Interrupt Request Acknowledge Timing (Minimum Time)



Remark 1 clock : $\frac{1}{f_{CPU}}$ (f_{CPU} : CPU clock)

Figure 21-15. Interrupt Request Acknowledge Timing (Maximum Time)



Remark 1 clock : $\frac{1}{f_{CPU}}$ (f_{CPU} : CPU clock)

21.4.3 Software interrupt request acknowledge operation

A software interrupt request is acknowledged by BRK instruction execution. Software interrupt cannot be disabled.

If a software interrupt request is acknowledged, the contents is saved in the stacks, program status word (PSW) and program counter (PC), in that order, the IE flag is reset to 0 and the contents of the vector tables (003EH and 003FH) are loaded into PC and branched.

Return from the software interrupt is possible with the RETB instruction.

Caution Do not use the RETI instruction for returning from the software interrupt.

21.4.4 Multiple interrupt servicing

Acknowledging another interrupt request while servicing an interrupt is called a multiple interrupt.

A multiple interrupt is not generated unless interrupt request acknowledge enabled state (IE = 1) is set (except non-maskable interrupt). When an interrupt request is acknowledged, interrupt request becomes acknowledge disabled state (IE = 0). Therefore, to enable a multiple interrupt, set IE flag to (1) with EI instruction during interrupt servicing, and set interrupt enable state.

In some cases, a multiple interrupt is not enabled even during interrupt enable state. It is controlled with the interrupt priority. There are two interrupt priorities : default priority and programmable priority. The multiple interrupt is controlled with programmable priority.

If an interrupt request of the same priority as or a higher priority than the interrupt currently being serviced is generated, it is acknowledged as a multiple interrupt. If an interrupt request of the priority lower than the interrupt currently being serviced is generated, it is not acknowledged as a multiple interrupt.

An interrupt request that is not acknowledged due to interrupt disable or low priority is reserved. The reserved interrupt request is acknowledged after the current interrupt servicing is completed and one instruction of the main processing is executed.

A multiple interrupt is not acknowledged while a non-maskable interrupt is being serviced.

Table 21-4 shows the interrupt requests that are capable of multiple interrupts, and Figure 21-16 shows examples of multiple interrupts.

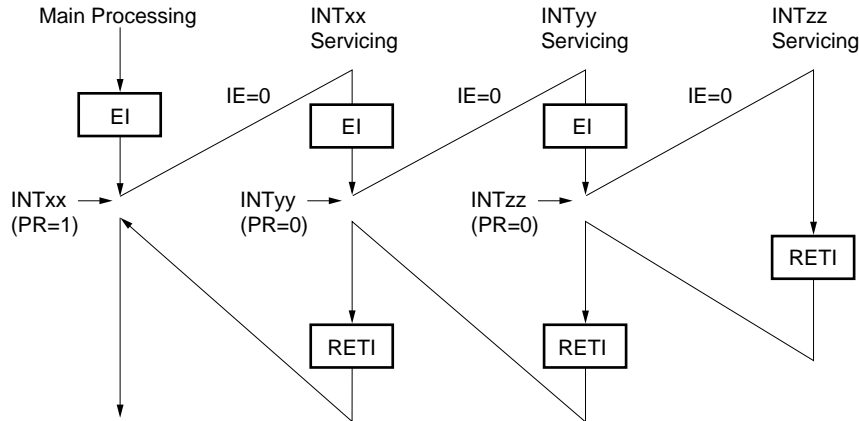
Table 21-4. Interrupt Request Enabled for Multiple Interrupt during Interrupt Servicing

Multiple Interrupt Request Interrupt being Serviced		Non-maskable Interrupt Request	Maskable Interrupt Request			
			PR = 0		PR = 1	
			IE = 1	IE = 0	IE = 1	IE = 0
Non-maskable interrupt		D	D	D	D	D
Maskable interrupt	ISP = 0	E	E	D	D	D
	ISP = 1	E	E	D	E	D
Software interrupt		E	E	D	E	D

- Remarks**
- E : Multiple interrupt enable
 - D : Multiple interrupt disable
 - ISP and IE are the flags contained in PSW
 - ISP=0 : An interrupt with higher priority is being serviced
 - ISP=1 : An interrupt request is not accepted or an interrupt with lower priority is being serviced
 - IE=0 : Interrupt request acknowledge is disabled
 - IE=1 : Interrupt request acknowledge is enabled
 - PR is a flag contained in PR0L, PR0H, and PR1L
 - PR=0 : Higher priority level
 - PR=1 : Lower priority level

Figure 21-16. Multiple Interrupt Example (1/2)

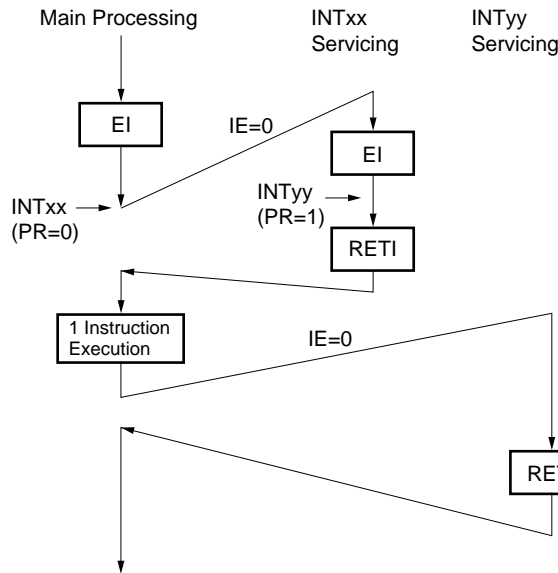
Example 1. A multiple interrupt is generated at twice



While servicing interrupt INTxx, two interrupt requests, INTyy and INTzz, are acknowledged, and a multiple interrupt is generated. Before each interrupt request acknowledgment, the EI instruction is always issued and interrupt request acknowledgment is enabled.

- PR = 0 : High priority level
- PR = 1 : Low priority level
- IE = 0 : Interrupt request acknowledgment disabled

Example 2. A multiple interrupt is not generated with priority control



Interrupt request INTyy generated while servicing interrupt INTxx is not acknowledged because it has a lower priority than INTxx, and a multiple interrupt is not generated. The INTyy request is reserved and acknowledged after execution of one main processing instruction.

- PR = 0 : High priority level
- PR = 1 : Low priority level
- IE = 0 : Interrupt request acknowledgment disabled

21.4.5 Interrupt request reserve

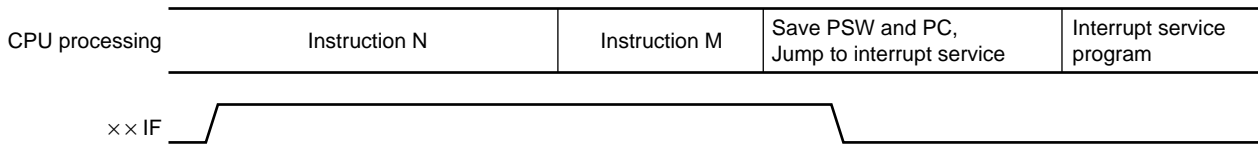
In some cases, the acknowledgment of the interrupt request is reserved even an interrupt request is generated during processing of the instruction until the execution of the next instruction is completed. The following shows this type of instructions (interrupt request reserve instruction).

- MOV PSW, #byte
- MOV A, PSW
- MOV PSW, A
- MOV1 PSW.bit, CY
- MOV1 CY, PSW.bit
- AND1 CY, PSW.bit
- OR1 CY, PSW.bit
- XOR1 CY, PSW.bit
- SET1 PSW.bit
- CLR1 PSW.bit
- RETB
- RETI
- PUSH PSW
- POP PSW
- BT PSW.bit, \$addr16
- BF PSW.bit, \$addr16
- BTCLR PSW.bit, \$addr16
- EI
- DI
- Manipulate instructions for IF0L, IF0H, IF1L, MK0L, MK0H, MK1L, PR0L, PR0H, PR1L, INTM0, INTM1 registers

Caution The BRK instruction is not an interrupt request reserve instruction shown above. However, in the case of software interrupt that is started up with the execution of the BRK instruction, the IE flag is cleared to 0. Therefore, interrupts are not acknowledged even when a maskable interrupt request is issued during the execution of the BRK instruction. However, non-maskable interrupt requests are acknowledged.

Figure 21-17 shows the timing when an interrupt request is reserved.

Figure 21-17. Interrupt Request Hold



- Remarks**
1. Instruction N: Instruction that holds interrupts requests
 2. Instruction M: Instructions other than instruction N
 3. The x xPR (priority level) values do not affect the operation of x xIF (interrupt request).

21.5 Test Functions

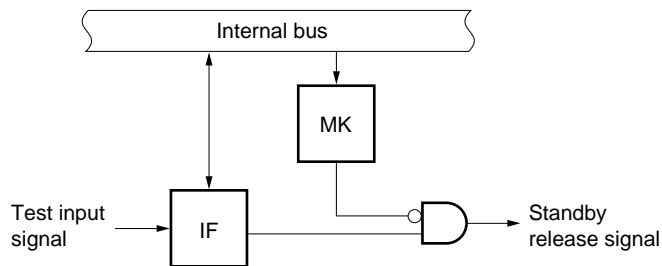
Upon occurrence of watch timer overflow and the detection of the falling falling edge of port 4, the corresponding test input flag is set (1) and a standby release signal is generated. Unlike in the case of interrupt functions, vector processing is not performed.

There are two test input sources as shown in Table 21-5. The basic configuration is shown in Figure 21-18.

Table 21-5. Test Input Factors

Test Input Factors		Internal/ external
Name	Trigger	
INTWT	Watch timer overflow	Internal
INTPT4	Falling edge detection at port 4	External

Figure 21-18. Basic Configuration of Test Function



Remark IF: test input flag
MK: test mask flag

21.5.1 Registers controlling the test function

The test function is controlled by the following three registers.

- Interrupt request flag register 1L (IF1L)
- Interrupt mask flag register 1L (MK1L)
- Key return mode register (KRM)

The names of the test input flags and test mask flags corresponding to the test input signals are listed in Table 21-6.

Table 21-6. Flags Corresponding to Test Input Signals

Test input signal name	Test input flag	Test mask flag
INTWT	WTIF	WTMK
INTPT4	KRIF	KRMK

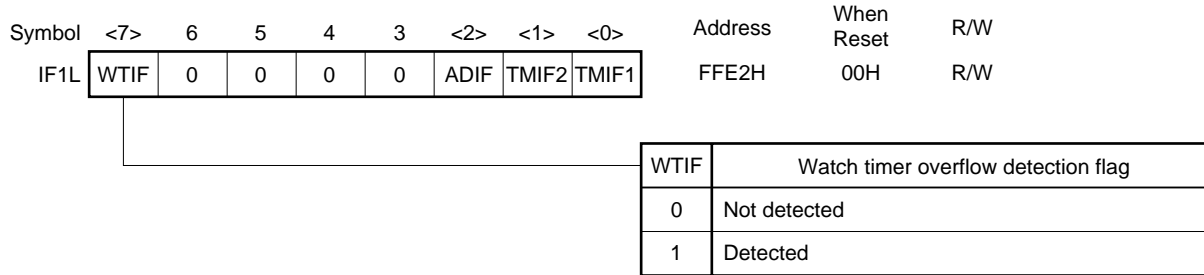
(1) Interrupt request flag register 1L (IF1L)

It indicates whether a watch timer overflow is detected or not.

It is set by a 1-bit memory manipulation instruction and 8-bit memory manipulation instruction.

It is set to 00H by the $\overline{\text{RESET}}$ signal input.

Figure 21-19. Format of Interrupt Request Flag Register 1L



Caution Be sure to set bits 3 through 6 to 0.

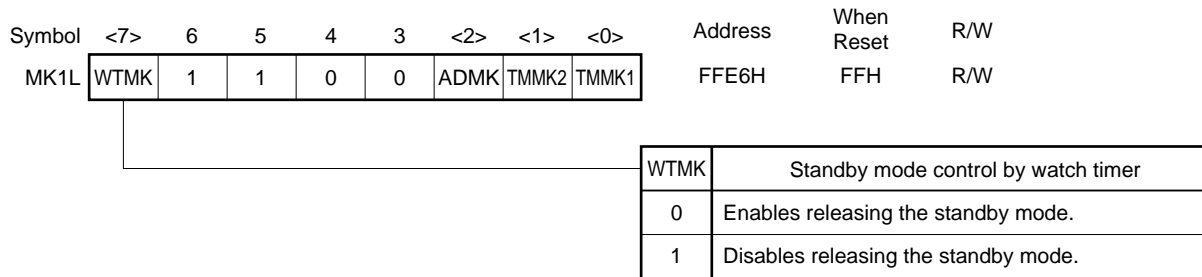
(2) Interrupt mask flag register 1L (MK1L)

It is used to set the standby mode enable/disable at the time the standby mode is released by the watch timer.

It is set by a 1-bit memory manipulation instruction and 8-bit memory manipulation instruction.

It is set to FFH by the $\overline{\text{RESET}}$ signal input.

Figure 21-20. Format of Interrupt Mask Flag Register 1L



Caution Be sure to set bits 3 through 6 to 1.

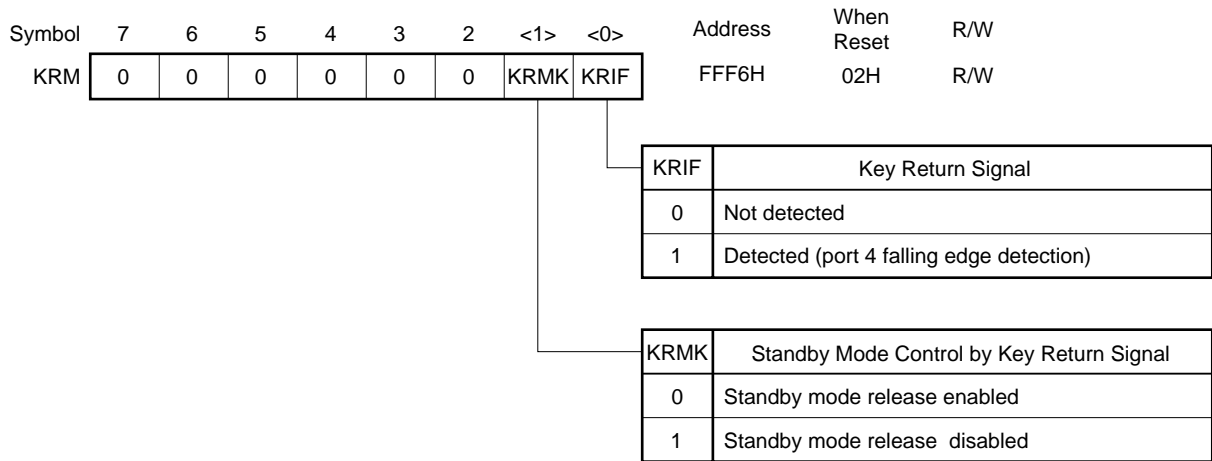
(3) Key return mode register (KRM)

This register is used to set enable/disable of standby function clear by key return signal (port 4 falling edge detection).

KRM is set with a 1-bit or 8-bit memory manipulation instruction.

RESET input sets KRM to 02H.

Figure 21-21. Key Return Mode Register Format



Caution When port 4 falling edge detection is used, be sure to clear KRIF to 0 (not cleared to 0 automatically)

21.5.2 Test input signal acknowledge operation

(1) Internal test signal

The internal test input signal (INTWT) is generated with watch timer overflow, and the WTIF flag is set. If not masked with bit 7 (WTMK) of interrupt mask flag register 1L (MK1L) at this time, a standby release signal is generated. The watch function is available by checking the WTIF flag using a shorter cycle than the watch timer overflow cycle.

(2) External test signal

When a falling edge (external test input signal) is input to the port 4 (P40 to P47) pins, KRIF is set. If not masked with bit 1 (KRMK) of key return mode register (KRM) at this time, a standby release signal is generated. If port 4 is used as key matrix return signal input, whether or not a key input has been applied can be checked from the KRIF status.

[MEMO]

CHAPTER 22 EXTERNAL DEVICE EXPANSION FUNCTION

22.1 External Device Expansion Functions

The external device expansion functions connect external devices to areas other than the internal ROM, RAM, and SFR. Connection of external devices uses ports 4 to 6. Ports 4 to 6 control address/data, read/write strobe, wait, address strobe etc.

Table 22-1. Pin Functions in External Memory Expansion Mode

Pin function at external device connection		Alternate function
Name	Function	
AD0 to AD7	Multiplexed address/data bus	P40 to P47
A8 to A15	Address bus	P50 to P57
\overline{RD}	Read strobe signal	P64
\overline{WR}	Write strobe signal	P65
\overline{WAIT}	Wait signal	P66
ASTB	Address strobe signal	P67

Table 22-2. State of Ports 4 to 6 Pins in External Memory Expansion Mode

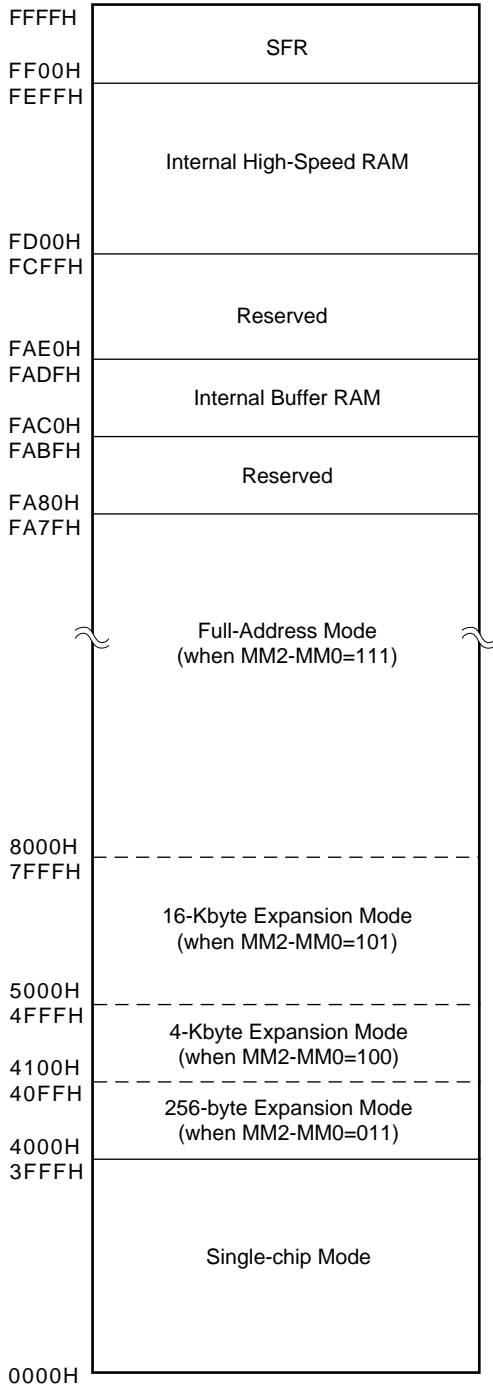
Ports and bits Modes	Port 4	Port 5								Port 6	
	0-7	0	1	2	3	4	5	6	7	0-3	4-7
Single-chip mode	Port	Port								Port	Port
256-byte expansion mode	Address/data	Port								Port	\overline{RD} , \overline{WR} , \overline{WAIT} , ASTB
4K-byte expansion mode	Address/data	Address				Port				Port	\overline{RD} , \overline{WR} , \overline{WAIT} , ASTB
16K-byte expansion mode	Address/data	Address				Port				Port	\overline{RD} , \overline{WR} , \overline{WAIT} , ASTB
Full address mode	Address/data	Address								Port	\overline{RD} , \overline{WR} , \overline{WAIT} , ASTB

Caution When the external wait function is not used, the \overline{WAIT} pin can be used as a port in all modes.

Memory maps when using the external device expansion function are as follows.

Figure 22-1. Memory Map when Using External Device Expansion Function (1/4)

(a) Memory map of μ PD78P054, 78P058, 78P058Y when the μ PD78052, 78052Y and internal PROM are 16 Kbytes



(b) Memory map of μ PD78P054, 78P058, 78P058Y when the μ PD78053, 78053Y and internal PROM are 24 Kbytes

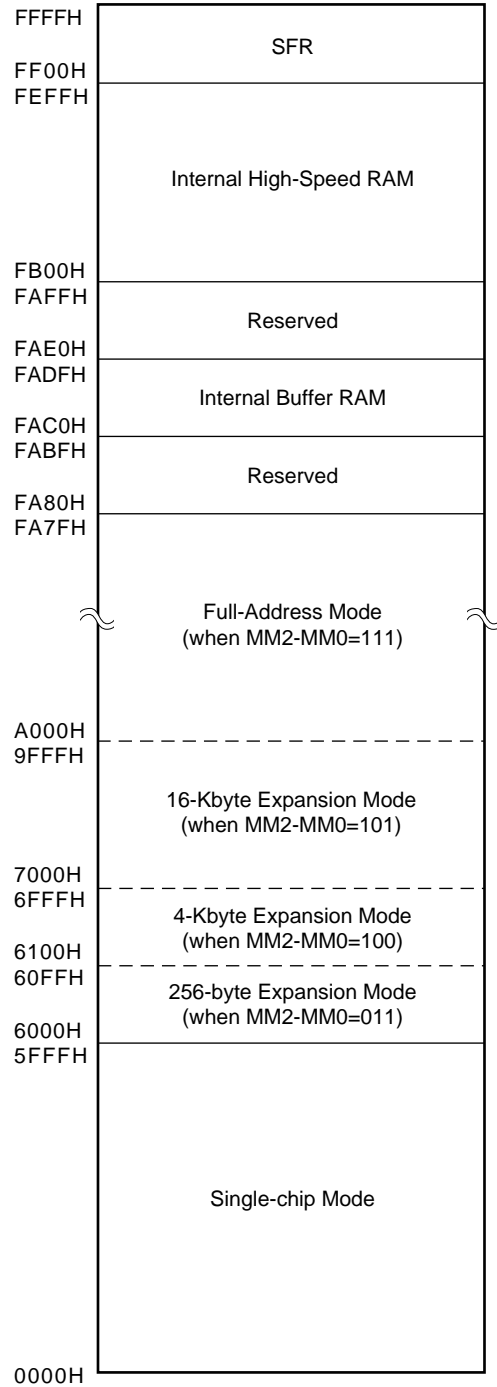


Figure 22-1. Memory Map when Using External Device Expansion Function (2/4)

(c) Memory map of μ PD78P054, 78P058, 78P058Y when the μ PD78054, 78054Y and internal PROM are 32 Kbytes

(d) Memory map of μ PD78P058, 78P058Y when the μ PD78055, 78055Y and internal PROM are 40 Kbytes

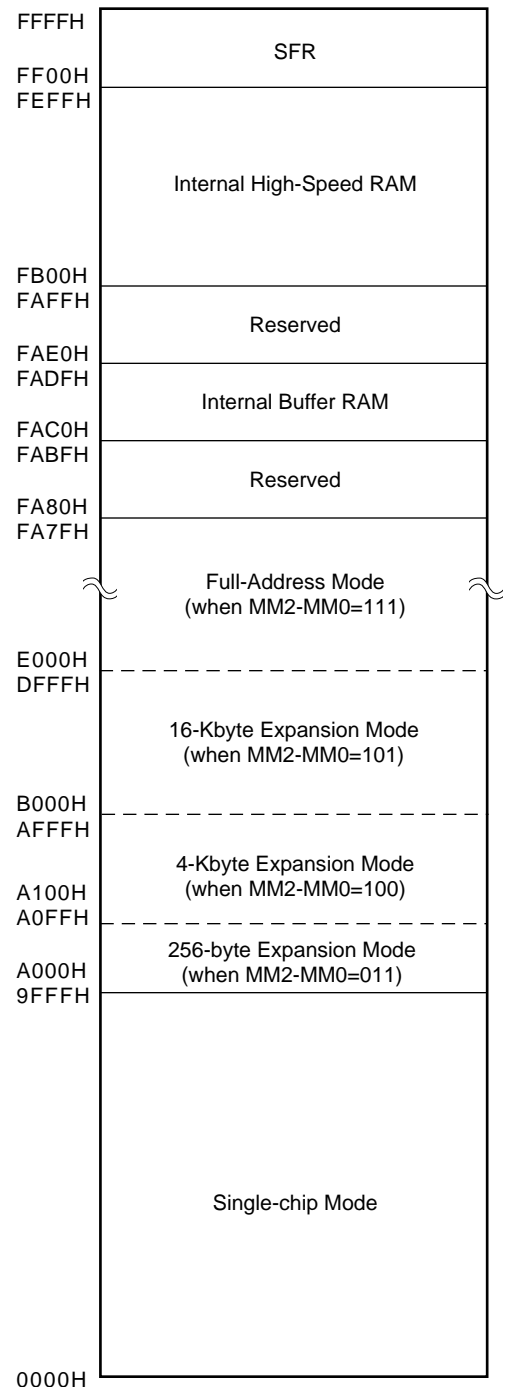
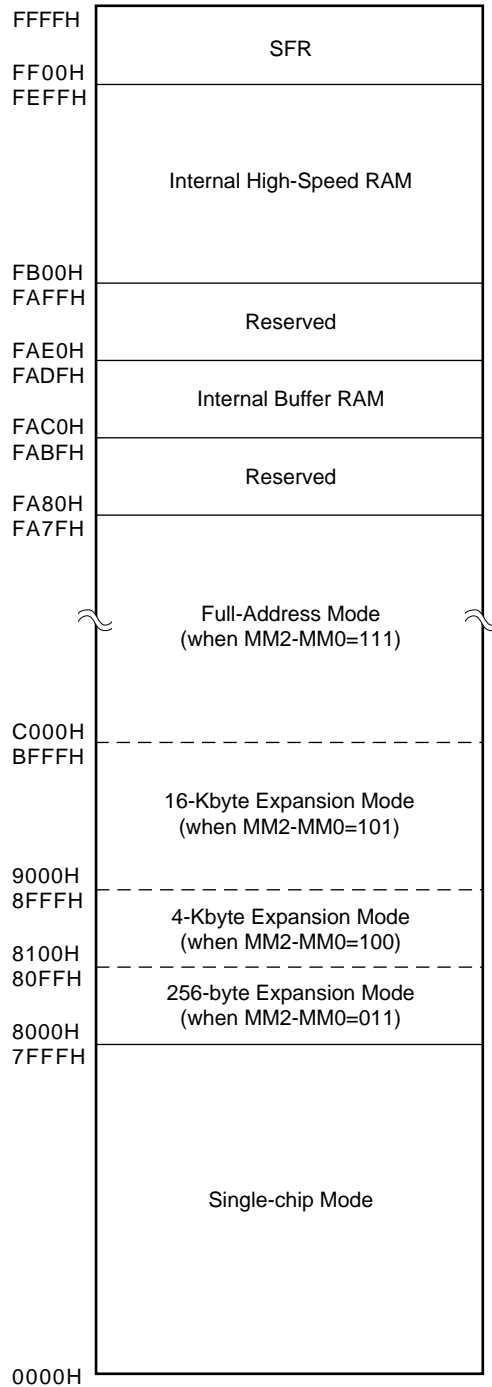


Figure 22-1. Memory Map when Using External Device Expansion Function (3/4)

(e) Memory map of μ PD78P058, 78P058Y
 when the μ PD78056, 78056Y and
 internal PROM are 48 Kbytes

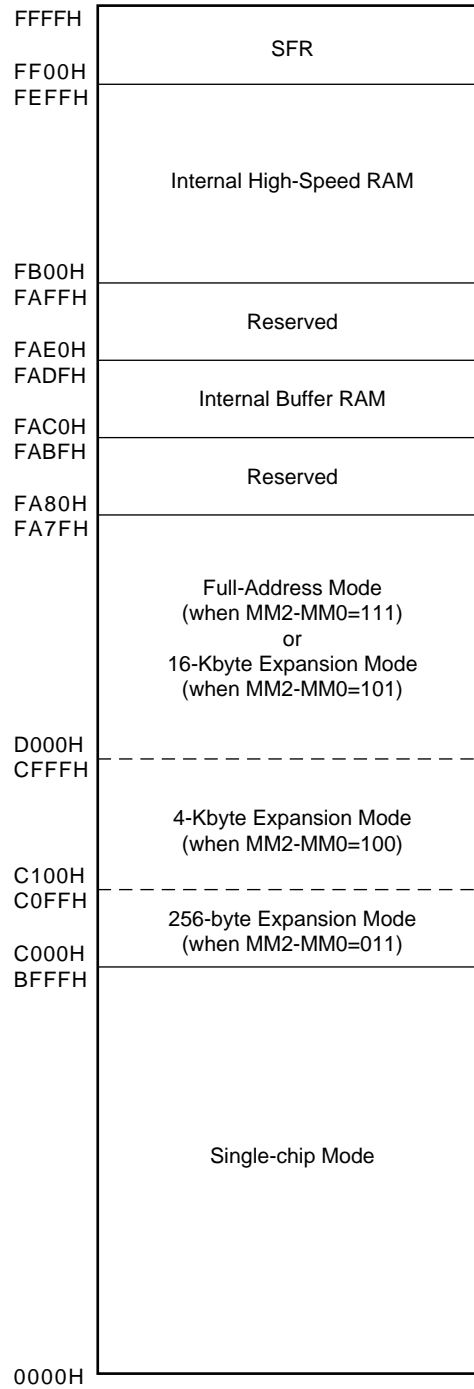
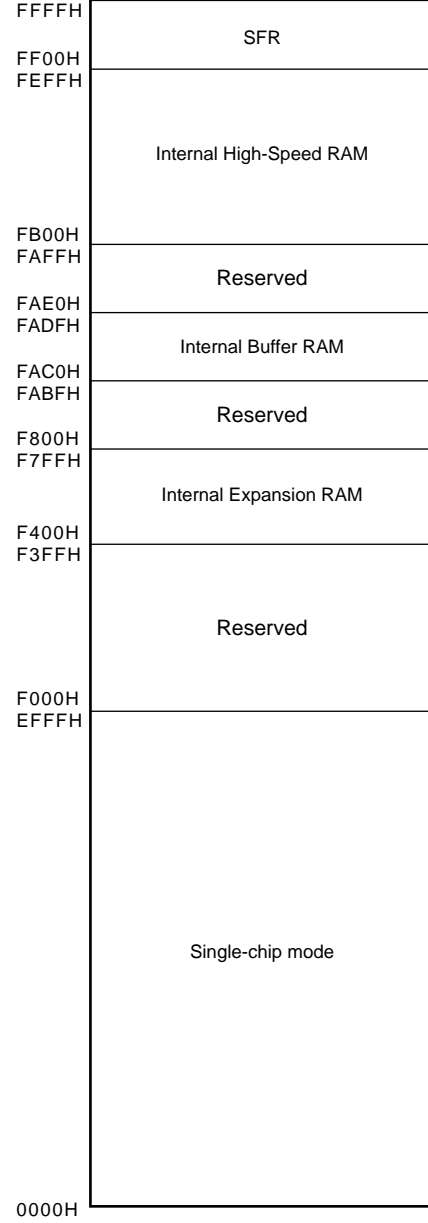
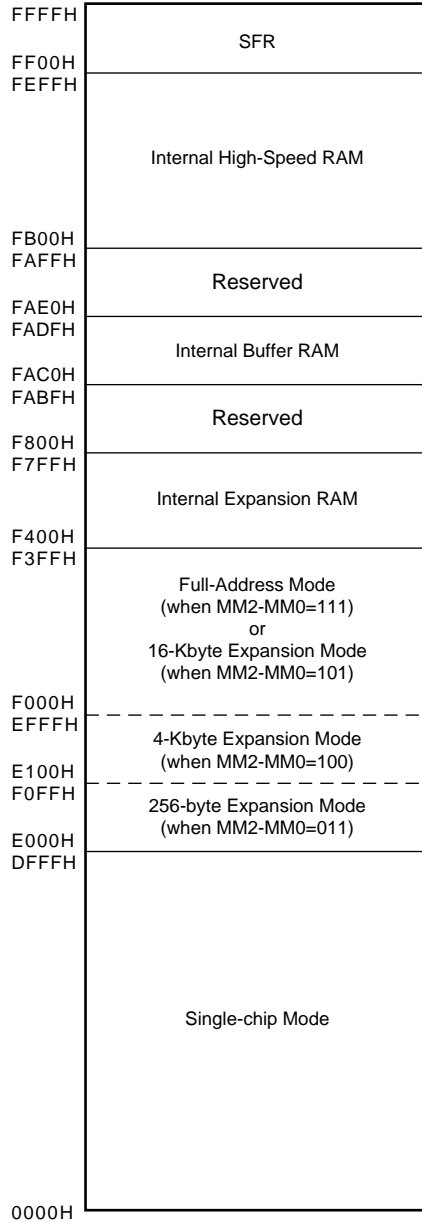


Figure 22-1. Memory Map when Using External Device Expansion Function (4/4)

(f) μ PD78058, 78058Y, 78P058, 78P058Y Memory map when internal ROM (PROM) size is 56 Kbytes

(g) μ PD78058, 78058Y, 78P058, 78P058Y Memory map when internal ROM (PROM) size is 60 Kbytes



Caution When the internal ROM (PROM) size is 60 Kbytes, the area from F000H to F3FFH cannot be used. F000H to F3FFH can be used as external memory by setting the internal ROM (PROM) size to less than 56 Kbytes by the memory size switching register (IMS).

22.2 External Device Expansion Function Control Register

The external device expansion function is controlled by the memory expansion mode register (MM) and memory size switching register (IMS).

(1) Memory expansion mode register (MM)

MM sets the wait count and external expansion area, and also sets the input/output of port 4.

MM is set with an 1-bit memory or 8-bit memory manipulation instruction.

$\overline{\text{RESET}}$ input sets this register to 10H.

Figure 22-2. Memory Expansion Mode Register Format

Symbol	7	6	5	4	3	2	1	0	Address	When Reset	R/W
MM	0	0	PW1	PW0	0	MM2	MM1	MM0	FFF8H	10H	R/W

MM2	MM1	MM0	Single-chip/ Memory Expansion Mode Selection		P40-P47, P50-P57, P64-P67 Pin state					
					P40-P47	P50-P53	P54, P55	P56, P57	P64-P67	
0	0	0	Single-chip mode		Port mode	Input	Port mode			
0	0	1				Output				
0	1	1	Memory expansion mode	256-byte mode	AD0-AD7	Port mode				
1	0	0		4K-byte mode		A8-A11	Port mode		P64= $\overline{\text{RD}}$ P65= $\overline{\text{WR}}$ P66= $\overline{\text{WAIT}}$ P67=ASTB	
1	0	1		16K-byte mode			A12, A13	Port mode		
1	1	1		Full address mode ^{Note}		A14, A15				
Other than above			Setting prohibited							

PW1	PW0	Wait Control
0	0	No wait
0	1	Wait (one wait state insertion)
1	0	Setting prohibited
1	1	Wait control by external wait pin

Note The full address mode allows external expansion to the entire 64-Kbyte address space except for the internal ROM, RAM, and SFR areas and the reserved areas.

Remark P60 to P63 enter the port mode without regard to the mode (single-chip mode or memory expansion mode).

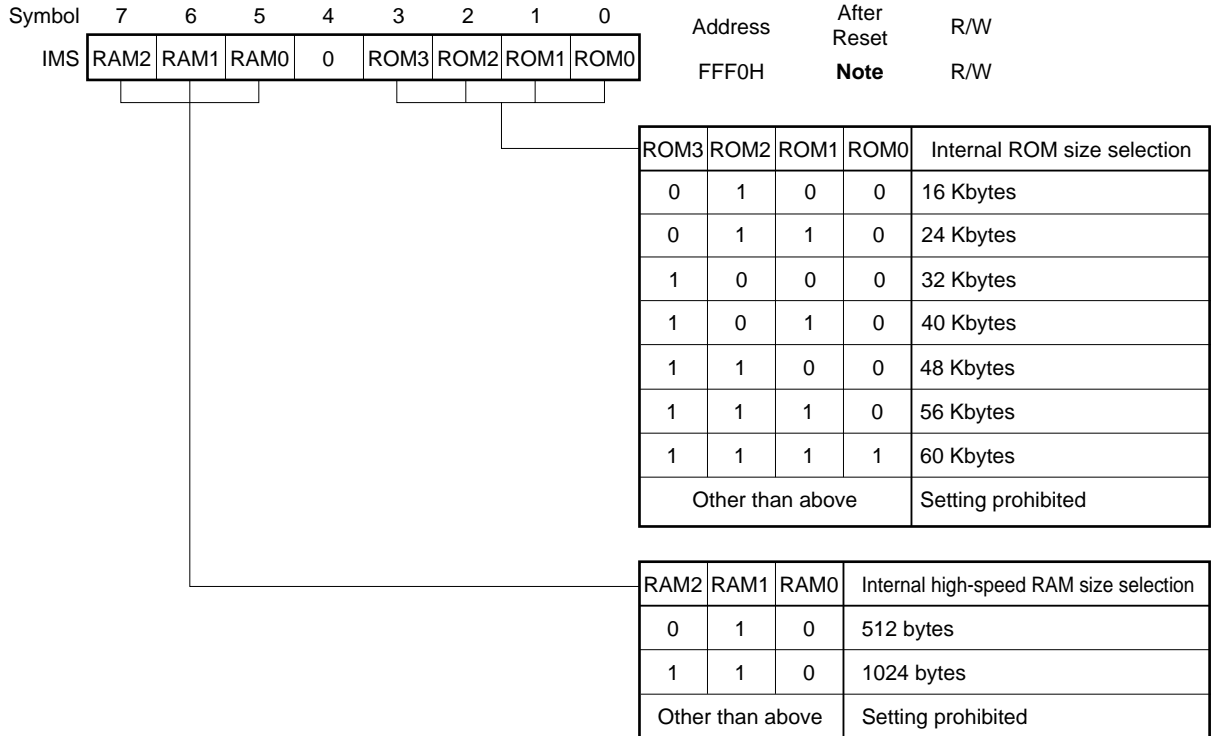
(2) Memory size switching register (IMS)

This register specifies the internal memory size. In principle, use IMS in a default status. However, when using the external device expansion function with the μ PD78058, set IMS so that the internal ROM capacity is 56 Kbytes or lower.

IMS is set with an 8-bit memory manipulation instruction.

$\overline{\text{RESET}}$ input sets this register to the value indicated in Table 22-3.

Figure 22-3. Memory Size Switching Register Format



Note The values after reset depend on the product. (See Table 22-3)

Table 22-3. Values when the Memory Size Switching Register is Reset

Part number	Reset value
μ PD78052, 78052Y	44H
μ PD78053, 78053Y	C6H
μ PD78054, 78054Y	C8H
μ PD78055, 78055Y	CAH
μ PD78056, 78056Y	CCH
μ PD78058, 78058Y	CFH

22.3 External Device Expansion Function Timing

Timing control signal output pins in the external memory expansion mode are as follows.

(1) $\overline{\text{RD}}$ pin (Alternate function: P64)

Read strobe signal output pin. The read strobe signal is output in data accesses and instruction fetches from external memory.

During internal memory access, the read strobe signal is not output (maintains high level).

(2) $\overline{\text{WR}}$ pin (Alternate function: P65)

Write strobe signal output pin. The write strobe signal is output in data access to external memory.

During internal memory access, the write strobe signal is not output (maintains high level).

(3) $\overline{\text{WAIT}}$ pin (Alternate function: P66)

External wait signal input pin. When the external wait is not used, the $\overline{\text{WAIT}}$ pin can be used as an input/output port.

During internal memory access, the external wait signal is ignored.

(4) ASTB pin (Alternate function: P67)

Address strobe signal output pin. Timing signal is output without regard to the data accesses and instruction fetches from external memory. The ASTB signal is also output when the internal memory is accessed.

(5) AD0 to AD7, A8 to A15 pins (Alternate function: P40 to P47, P50 to P57)

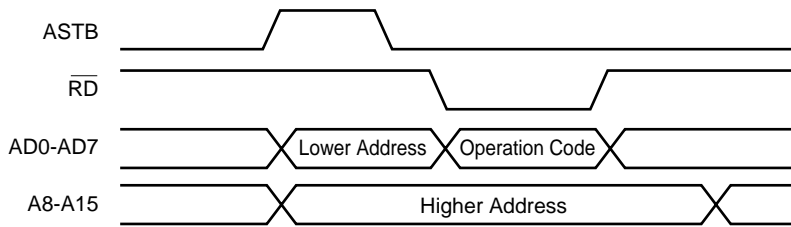
Address/data signal output pin. Valid signal is output or input during data accesses and instruction fetches from external memory.

These signals change when the internal memory is accessed (output values are undefined).

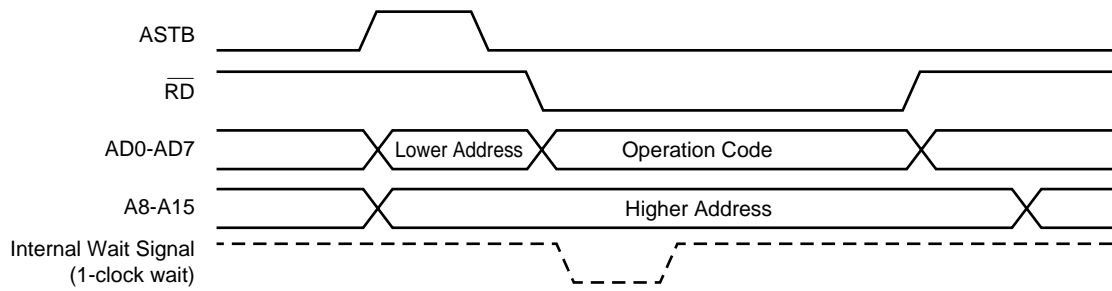
Timing charts are shown in Figure 22-4 to 22-7.

Figure 22-4. Instruction Fetch from External Memory

(a) No wait (PW1, PW0 = 0, 0) setting



(b) Wait (PW1, PW0 = 0, 1) setting



(c) External wait (PW1, PW0 = 1, 1) setting

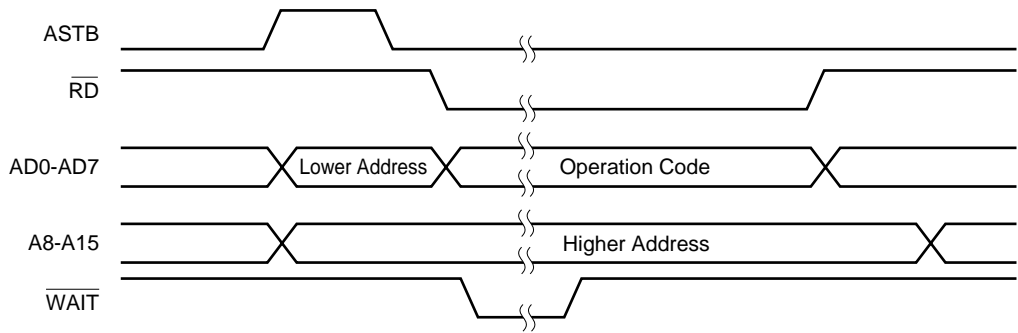
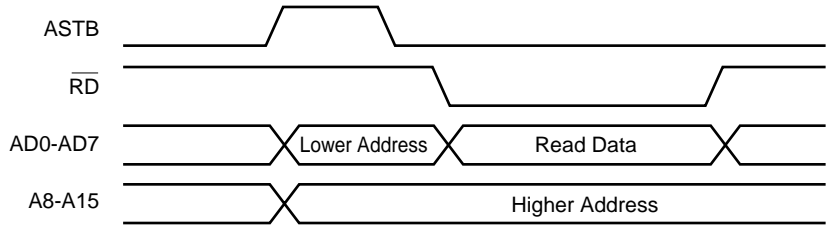
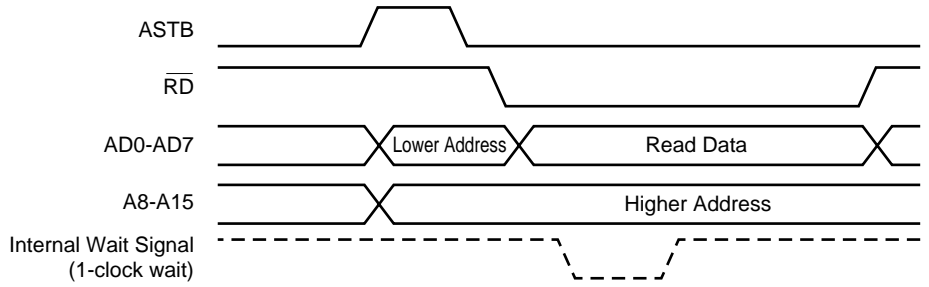


Figure 22-5. External Memory Read Timing

(a) No wait (PW1, PW0 = 0, 0) setting



(b) Wait (PW1, PW0 = 0, 1) setting



(c) External wait (PW1, PW0 = 1, 1) setting

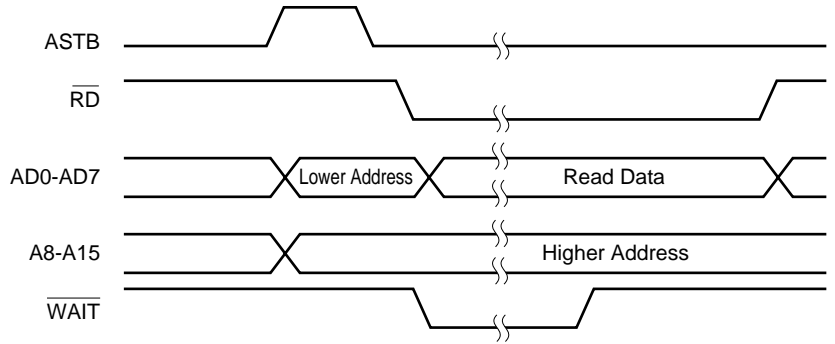
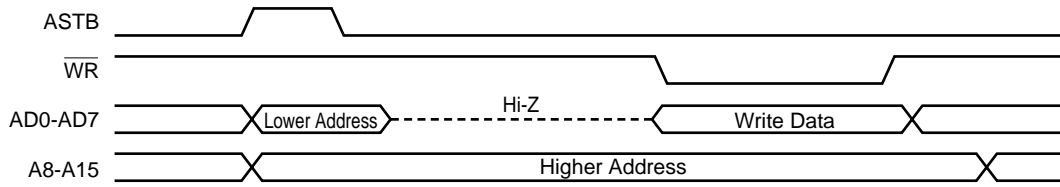
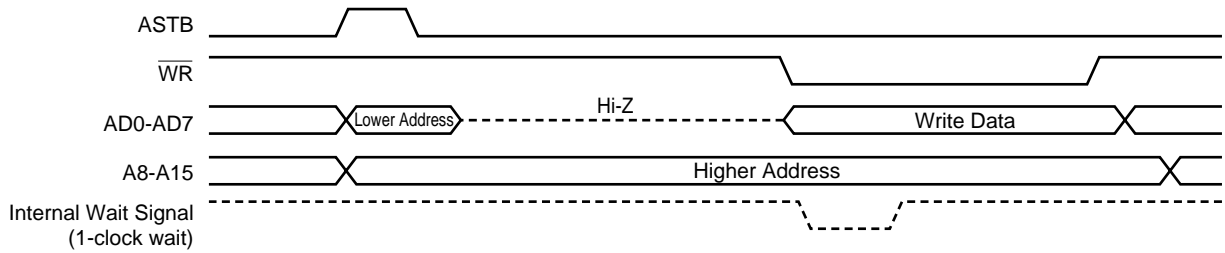


Figure 22-6. External Memory Write Timing

(a) No wait (PW1, PW0 = 0, 0) setting



(b) Wait (PW1, PW0 = 0, 1) setting



(c) External wait (PW1, PW0 = 1, 1) setting

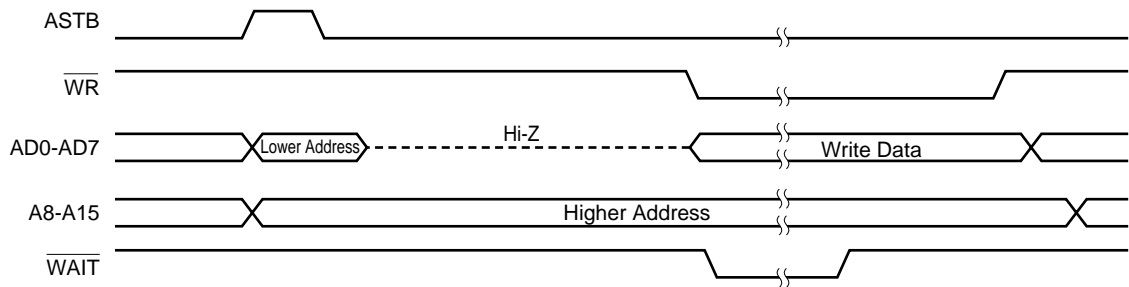
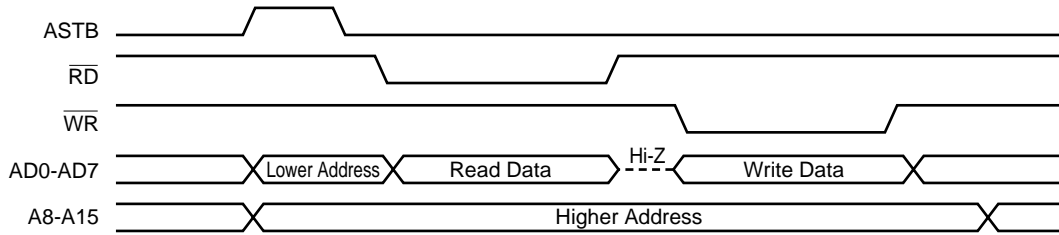
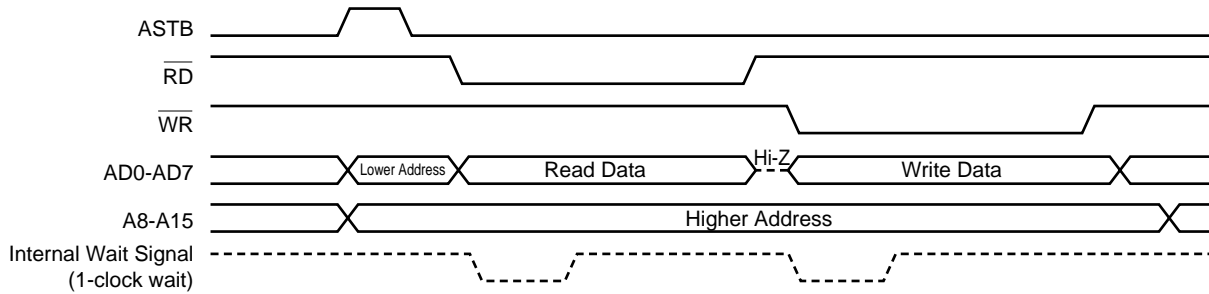


Figure 22-7. External Memory Read Modify Write Timing

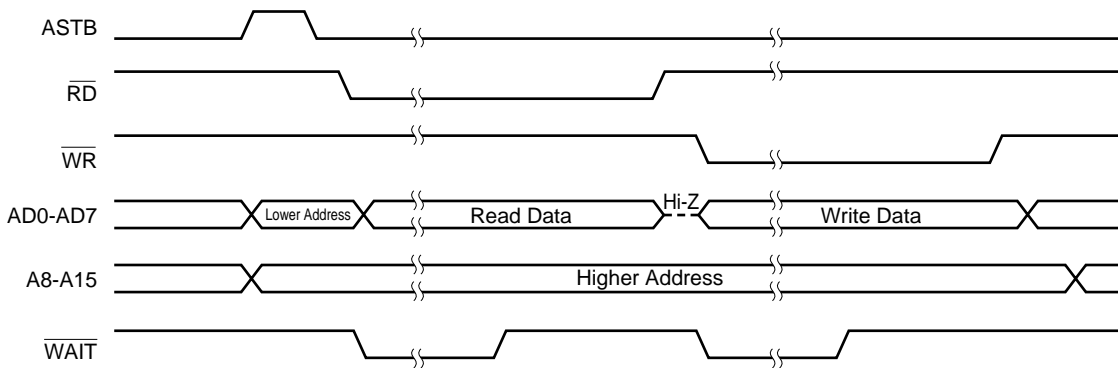
(a) No wait (PW1, PW0 = 0, 0) setting



(b) Wait (PW1, PW0 = 0, 1) setting



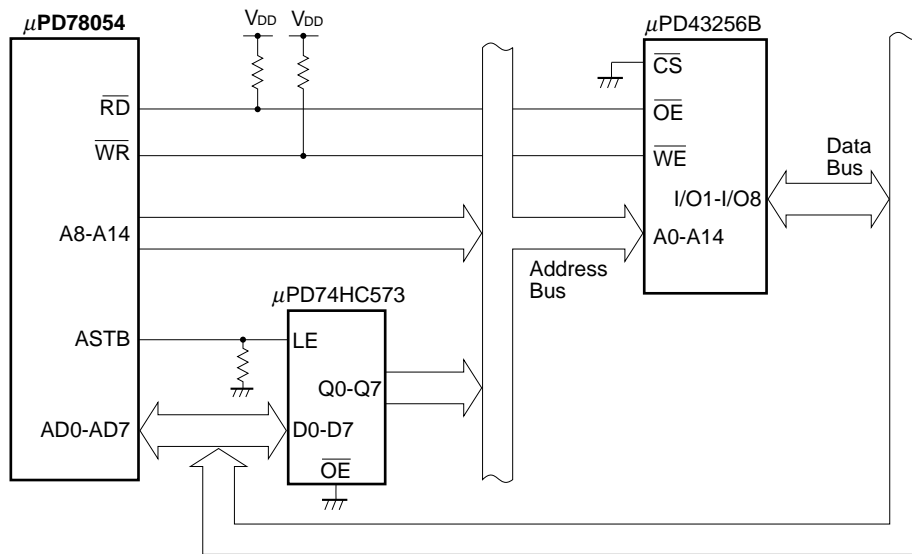
(c) External wait (PW1, PW0 = 1, 1) setting



22.4 Example of Connection with Memory

This section provides μ PD78054 and external memory connection examples in Figure 22-8. SRAMs are used as the external memory in these diagrams. In addition, the external device expansion function is used in the full-address mode, and the address from 0000H to 7FFFH (32 Kbytes) are allocated for internal ROM, and the addresses after 8000H for SRAM.

Figure 22-8. Connection Example of μ PD78054 and Memory



[MEMO]

23.1 Standby Function and Configuration

23.1.1 Standby function

The standby function is designed to decrease power consumption of the system. The following two modes are available.

(1) HALT mode

HALT instruction execution sets the HALT mode. The HALT mode is intended to stop the CPU operation clock. System clock oscillator continues oscillation. In this mode, current consumption cannot be decreased as in the STOP mode. The HALT mode is valid to restart immediately upon interrupt request and to carry out intermittent operations such as in watch applications.

(2) STOP mode

STOP instruction execution sets the STOP mode. In the STOP mode, the main system clock oscillator stops and the whole system stops. CPU current consumption can be considerably decreased.

Data memory low-voltage hold (down to $V_{DD} = 1.8$ V) is possible. Thus, the STOP mode is effective to hold data memory contents with ultra-low current consumption. Because this mode can be cleared upon interrupt request, it enables intermittent operations to be carried out.

However, because a wait time is necessary to secure an oscillation stabilization time after the STOP mode is cleared, select the HALT mode if it is necessary to start processing immediately upon interrupt request.

In any mode, all the contents of the register, flag and data memory just before standby mode setting are held. The input/output port output latch and output buffer statuses are also held.

- Cautions**
1. The STOP mode can be used only when the system operates with the main system clock (subsystem clock oscillation cannot be stopped). The HALT mode can be used with either the main system clock or the subsystem clock.
 2. When proceeding to the STOP mode, be sure to stop the peripheral hardware operation and execute the STOP instruction.
 3. The following sequence is recommended for power consumption reduction of the A/D converter when the standby function is used: first clear bit 7 (CS) of A/D converter mode register (ADM) to 0 to stop the A/D conversion operation, and then execute the HALT or STOP instruction.

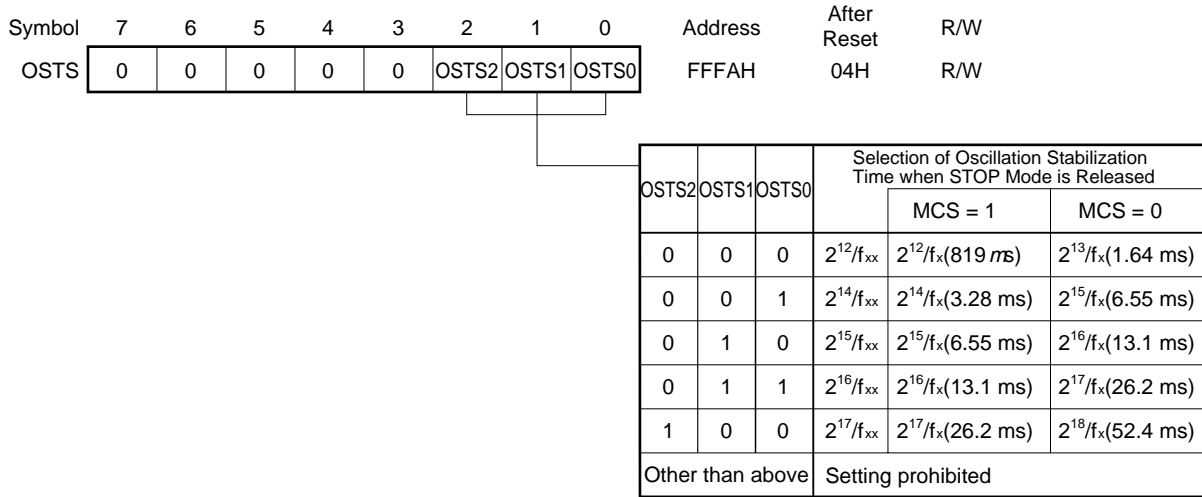
23.1.2 Standby function control register

A wait time after the STOP mode is cleared upon interrupt request till the oscillation stabilizes is controlled with the oscillation stabilization time select register (OSTS).

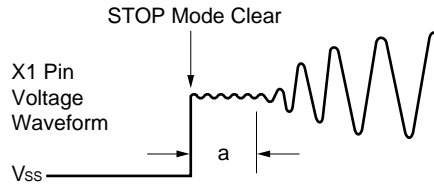
OSTS is set with an 8-bit memory manipulation instruction.

$\overline{\text{RESET}}$ input sets OSTS to 04H. However, it takes $2^{17}/f_x$, not $2^{18}/f_x$, until the STOP mode is cleared by $\overline{\text{RESET}}$ input.

Figure 23-1. Oscillation Stabilization Time Select Register Format



Caution The wait time after STOP mode clear does not include the time (see "a" in the illustration below) from STOP mode clear to clock oscillation start, regardless of clearance by $\overline{\text{RESET}}$ input or by interrupt request generation.



- Remarks**
1. f_{xx} : Main system clock frequency (f_x or $f_x/2$)
 2. f_x : Main system clock oscillation frequency
 3. MCS : Bit 0 of oscillation mode select register (OSMS)
 4. Values in parentheses apply to operating at $f_x = 5.0\text{ MHz}$

23.2 Standby Function Operations

23.2.1 HALT mode

(1) HALT mode set and operating status

The HALT mode is set by executing the HALT instruction. It can be set with the main system clock or the subsystem clock.

The operating status in the HALT mode is described below.

Table 23-1. HALT Mode Operating Status

Setting of HALT Mode		On Execution of HALT Instruction during Main System Clock Operation		On Execution of HALT Instruction during Subsystem Clock Operation	
		Without subsystem clock ^{Note 1}	With subsystem clock ^{Note 1}	When main system clock continues oscillation	When main system clock stops oscillation
Item					
Clock generator		Both main system and subsystem clocks can be oscillated. Clock supply to the CPU stops.			
CPU		Operation stops.			
Port (output latch)		Status before HALT mode setting is held.			
16-bit timer/event counter		Operable.		Operable when watch timer output is selected as count clock (f_{XT} is selected as count clock of watch timer) or when TI00 is selected.	
8-bit timer/event counter		Operable.		Operable when TI1 or TI2 is selected as count clock.	
Watch timer		Operable when $f_{XX}/2^7$ is selected as count clock.	Operable.	Operable when f_{XT} is selected as count clock.	
Watchdog timer		Operable.		Operation stops.	
A/D converter		Operable.			Operation stops.
D/A converter		Operable.			
Real-time output port		Operable.			
Serial interface	Other than automatic transmit/receive function	Operable.			Operable when external SCK is used.
	Automatic transmit/receive function	Operation stops.			
External interrupt	INTP0	INTP0 is operable when clock supplied for peripheral hardware is selected as sampling clock ($f_{XX}/2^5$, $f_{XX}/2^6$, $f_{XX}/2^7$).			Operation stops.
	INTP1-INTP6	Operable.			
Bus line for external expansion	AD0-AD7	High impedance.			
	A0-A15	Status before HALT mode setting is held.			
	ASTB	Low level.			
	\overline{WR} , \overline{RD}	High level.			
	\overline{WAIT}	High impedance.			

- Notes**
1. Including when external clock is not supplied
 2. Including when external clock is supplied

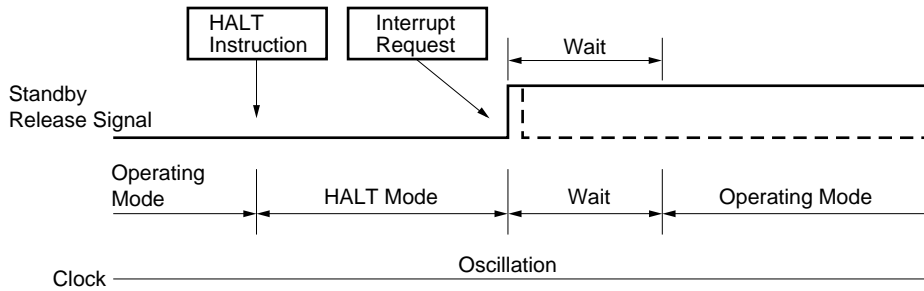
(2) HALT mode clear

The HALT mode can be cleared with the following four types of sources.

(a) Clear upon unmasked interrupt request

When an unmasked interrupt request is generated, the HALT mode is cleared. If interrupt request acknowledge is enabled, vectored interrupt service is carried out. If disabled, the next address instruction is executed.

Figure 23-2. HALT Mode Clear upon Interrupt Request Generation



Remarks 1. The broken line indicates the case when the interrupt request which has cleared the standby status is acknowledged.

2. Wait time will be as follows:

- When vectored interrupt service is carried out: 8 to 9 clocks
- When vectored interrupt service is not carried out: 2 to 3 clocks

(b) Clear upon non-maskable interrupt request

When a non-maskable interrupt request is generated, the HALT mode is cleared and vectored interrupt service is carried out whether interrupt acknowledge is enabled or disabled.

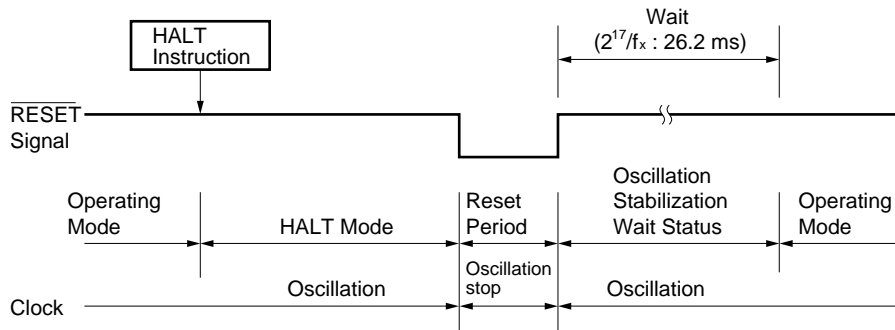
(c) Clear upon unmasked test input

When an unmasked test signal is input, the HALT mode is cleared and the next address instruction of the HALT instruction is executed.

(d) Clear upon $\overline{\text{RESET}}$ input

When a $\overline{\text{RESET}}$ signal is input, the HALT mode is released, and as is the case with normal reset operation, a program is executed after branch to the reset vector address.

Figure 23-3. HALT Mode Release by $\overline{\text{RESET}}$ Input



- Remarks**
1. f_x : main system clock oscillation frequency
 2. (): f_x : 5.0 MHz

Table 23-2. Operation after HALT Mode Release

Release Source	MK $\times\times$	PR $\times\times$	IE	ISP	Operation
Maskable interrupt request	0	0	0	×	Next address instruction execution
	0	0	1	×	Interrupt service execution
	0	1	0	1	Next address instruction execution
	0	1	×	0	
	0	1	1	1	Interrupt service execution
1	×	×	×	HALT mode hold	
Non-maskable interrupt request	–	–	×	×	Interrupt service execution
Test input	0	–	×	×	Next address instruction execution
	1	–	×	×	HALT mode hold
$\overline{\text{RESET}}$ input	–	–	×	×	Reset processing

Remark x: Don't care

23.2.2 STOP mode

(1) STOP mode set and operating status

The STOP mode is set by executing the STOP instruction. It can be set only with the main system clock.

Cautions 1. When the STOP mode is set, the X2 pin is internally connected to V_{DD} via a pull-up resistor to minimize the leakage current at the crystal oscillator. Thus, do not use the STOP mode in a system where an external clock is used for the main system clock.

2. Because the interrupt request signal is used to clear the standby mode, if there is an interrupt source with the interrupt request flag set and the interrupt mask flag reset, the standby mode is immediately cleared if set. Thus, the STOP mode is reset to the HALT mode immediately after execution of the STOP instruction. After the wait set using the oscillation stabilization time select register (OSTS), the operating mode is set.

The operating status in the STOP mode is described below.

Table 23-3. STOP Mode Operating Status

Setting of STOP Mode		With subsystem clock	Without subsystem clock
Item			
Clock generator		Only main system clock stops oscillation.	
CPU		Operation stops.	
Port (output latch)		Status before STOP mode setting is held.	
16-bit timer/event counter		Operable when watch timer output is selected as count clock (f _{XT} is selected as count clock of watch timer)	Operation stops.
8-bit timer/event counter		Operable when T11 and T12 are selected for the count clock.	
Watch timer		Operable when f _{XT} is selected for the count clock.	Operation stops.
Watchdog timer		Operation stops.	
A/D converter			
D/A converter		Operable.	
Real-time output port		Operable when external trigger is used or T11 and T12 are selected for the 8-bit timer/event counter count clock.	
Serial interface	Other than automatic transmit/receive function and UART	Operable when externally supplied clock is specified as the serial clock.	
	Automatic transmit/receive function and UART	Operation stops.	
External interrupt	INTP0	Not operable.	
	INTP1-INTP6	Operable.	
Bus line for external expansion	AD0-AD7	High impedance.	
	A0-A15	Status before STOP mode setting is held.	
	ASTB	Low level.	
	\overline{WR} , \overline{RD}	High level.	
	\overline{WAIT}	High impedance.	

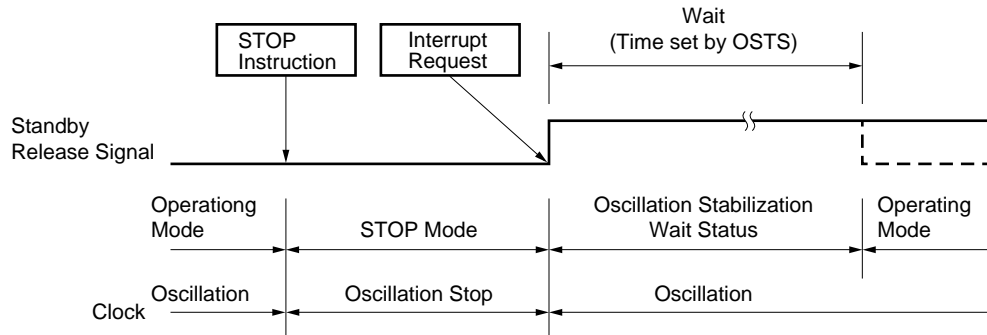
(2) STOP mode release

The STOP mode can be cleared with the following three types of sources.

(a) Release by unmasked interrupt request

When an unmasked interrupt request is generated, the STOP mode is cleared. If interrupt request acknowledge is enabled after the lapse of oscillation stabilization time, vectored interrupt service is carried out. If interrupt request acknowledge is disabled, the next address instruction is executed.

Figure 23-4. STOP Mode Release by Interrupt Request Generation



Remark The broken line indicates the case when the interrupt request which has cleared the standby status is acknowledged.

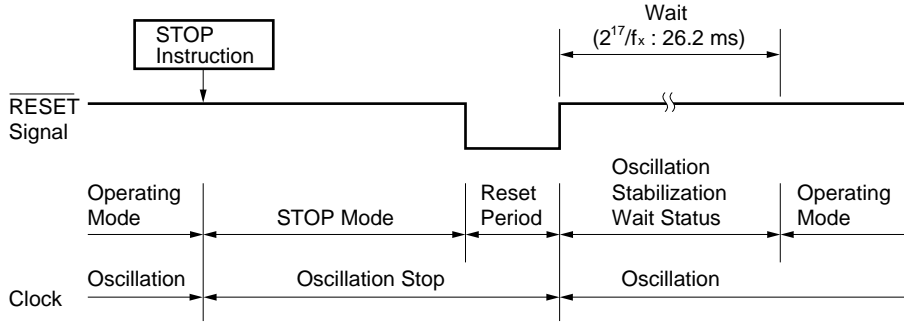
(b) Release by unmasked test input

When an unmasked test signal is input, the STOP mode is cleared. And after the lapse of oscillation stabilization time, the instruction at the next address of the STOP instruction is executed.

(c) Release by $\overline{\text{RESET}}$ input

When a $\overline{\text{RESET}}$ signal is input, the STOP mode is released. And after the lapse of oscillation stabilization time, reset operation is carried out.

Figure 23-5. Release by STOP Mode $\overline{\text{RESET}}$ Input



- Remarks**
1. f_x : main system clock oscillation frequency
 2. (): f_x : 5.0 MHz

Table 23-4. Operation after STOP Mode Release

Release Source	MKxx	PRxx	IE	ISP	Operation
Maskable interrupt request	0	0	0	×	Next address instruction execution
	0	0	1	×	Interrupt service execution
	0	1	0	1	Next address instruction execution
	0	1	×	0	
	0	1	1	1	Interrupt service execution
	1	×	×	×	STOP mode hold
Test input	0	–	×	×	Next address instruction execution
	1	–	×	×	STOP mode hold
$\overline{\text{RESET}}$ input	–	–	×	×	Reset processing

Remark ×: Don't care

CHAPTER 24 RESET FUNCTION

24.1 Reset Function

The following two operations are available to generate the reset signal.

- (1) External reset input with $\overline{\text{RESET}}$ pin
- (2) Internal reset by watchdog timer overrun time detection

External reset and internal reset have no functional differences. In both cases, program execution starts at the address at 0000H and 0001H by $\overline{\text{RESET}}$ input.

When a low level is input to the $\overline{\text{RESET}}$ pin or the watchdog timer overflows, a reset is applied and each hardware is set to the status as shown in Table 24-1. Each pin has high impedance during reset input or during oscillation stabilization time just after reset clear.

When a high level is input to the $\overline{\text{RESET}}$ input, the reset is cleared and program execution starts after the lapse of oscillation stabilization time ($2^{17}/f_x$). The reset applied by watchdog timer overflow is automatically cleared after a reset and program execution starts after the lapse of oscillation stabilization time ($2^{17}/f_x$) (see **Figure 24-2** to **24-4**).

- Cautions**
1. For an external reset, input a low level for 10 μs or more to the $\overline{\text{RESET}}$ pin.
 2. During reset input, main system clock oscillation remains stopped but subsystem clock oscillation continues.
 3. When the STOP mode is cleared by reset, the STOP mode contents are held during reset input. However, the port pin becomes high-impedance.

Figure 24-1. Block Diagram of Reset Function

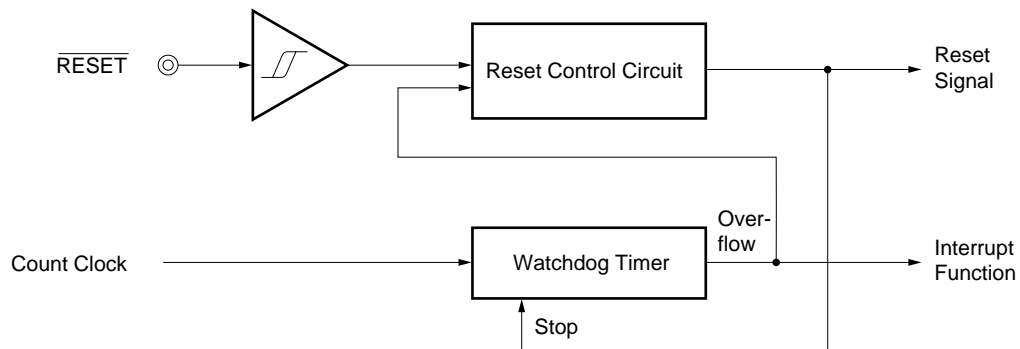


Figure 24-2. Timing of Reset Input by $\overline{\text{RESET}}$ Input

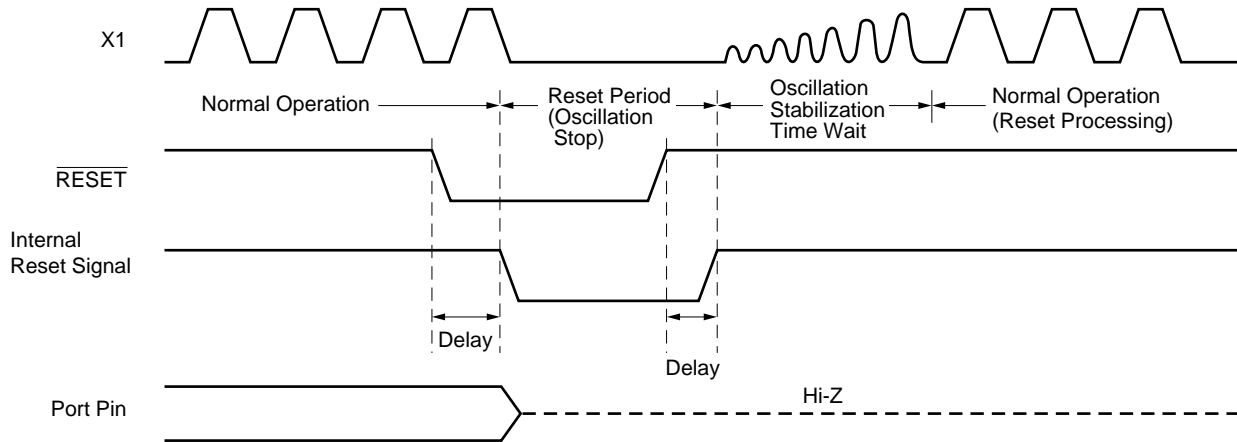


Figure 24-3. Timing of Reset due to Watchdog Timer Overflow

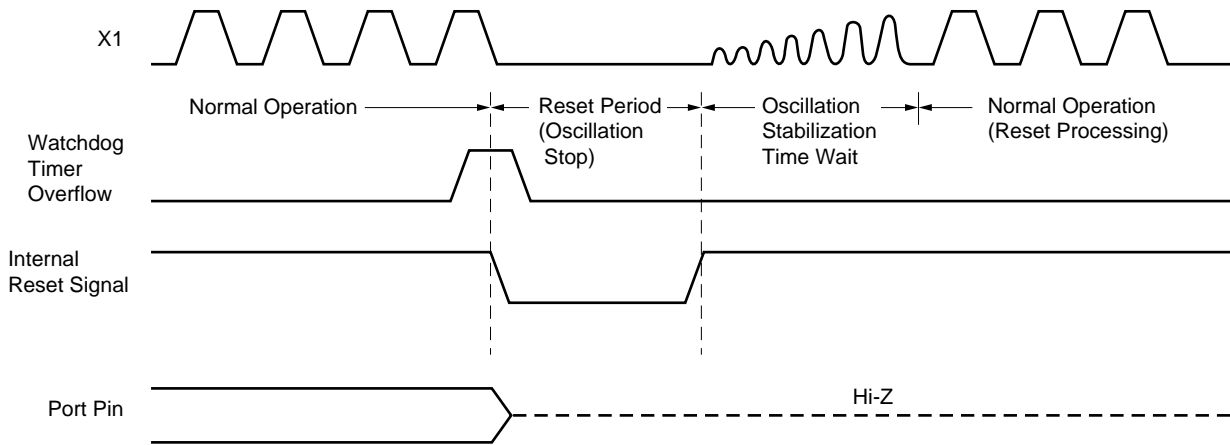


Figure 24-4. Timing of Reset Input in STOP Mode by $\overline{\text{RESET}}$ Input

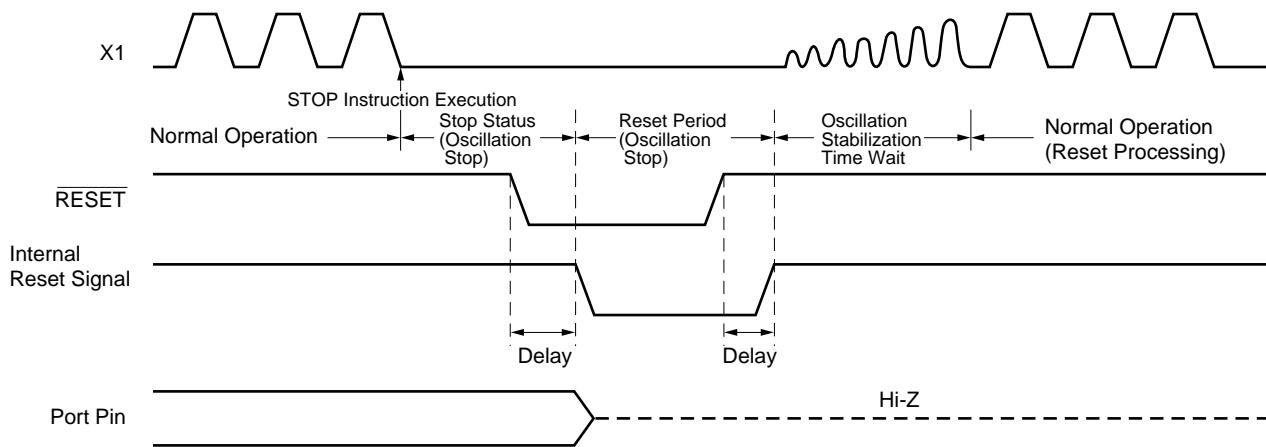


Table 24-1. Hardware Status after Reset (1/2)

Hardware		Status after Reset
Program counter (PC) Note1		The contents of reset vector tables (0000H and 0001H) are set.
Stack pointer (SP)		Undefined
Program status word (PSW)		02H
RAM	Data memory	Undefined Note2
	General register	Undefined Note2
Port (Output latch)	Ports 0 to 3, Port 7, Port 12, Port 13 (P0 to P3, P7, P12, P13)	00H
	Ports 4 to 6 (P4 to P6)	Undefined
Port mode register (PM0 to PM3, PM5 to PM7, PM12, PM13)		FFH
Pull-up resistor option register (PUOH, PUOL)		00H
Processor clock control register (PCC)		04H
Oscillation mode selection register (OSMS)		00H
Memory size switching register (IMS)		Note3
Internal expansion RAM size switching register (IXS) Note4		0AH
Memory expansion mode register (MM)		10H
Oscillation stabilization time select register (OSTS)		04H
16-bit timer/event counter	Timer register (TM0)	0000H
	Capture/compare register (CR00, CR01)	Undefined
	Clock selection register (TCL0)	00H
	Mode control register (TMC0)	00H
	Capture/compare control register 0 (CRC0)	04H
	Output control register (TOC0)	00H
8-bit timer/event counter 1 and 2	Timer register (TM1, TM2)	00H
	Compare registers (CR10, CR20)	Undefined
	Clock select register (TCL1)	00H
	Mode control registers (TMC1)	00H
	Output control register (TOC1)	00H

- Notes**
1. During reset input or oscillation stabilization time wait, only the PC contents among the hardware statuses become undefined. All other hardware statuses remains unchanged after reset.
 2. When reset in the standby mode, the state before reset is held even after reset.
 3. The values after reset depend on the product.
 μ PD78052, 78052Y : 44H, μ PD78053, 78053Y : C6H, μ PD78054, 78054Y : C8H,
 μ PD78P054 : C8H, μ PD78055, 78055Y : CAH, μ PD78056, 78056Y : CCH,
 μ PD78058, 78058Y : CFH, μ PD78P058, 78P058Y: CFH
 4. Provided only in the μ PD78058, 78058Y, 78P058, and 78P058Y.

Table 24-1. Hardware Status after Reset (2/2)

	Hardware	Status after Reset	
Watch timer	Mode control register (TMC2)	00H	
	Clock select register (TCL2)	00H	
Watchdog timer	Mode register (WDTM)	00H	
	Clock select register (TCL3)	88H	
Serial interface	Shift registers (SIO0, SIO1)	Undefined	
	Mode registers (CSIM0, CSIM1, CSIM2)	00H	
	Serial bus interface control register (SBIC)	00H	
	Slave address register (SVA)	Undefined	
	Automatic data transmit/receive control register (ADTC)	00H	
	Automatic data transmit/receive address pointer (ADTP)	00H	
	Automatic data transmit/receive interval specify register (ADTI)	00H	
	Asynchronous serial interface mode register (ASIM)	00H	
	Asynchronous serial interface status register (ASIS)	00H	
	Baud rate generator control register (BRGC)	00H	
	Transmit shift register (TXS)	FFH	
	Receive buffer register (RXB)		
	Interrupt timing specify register (SINT)	00H	
	A/D converter	Mode register (ADM)	01H
		Conversion result register (ADCR)	Undefined
Input select register (ADIS)		00H	
D/A converter	Mode register (DAM)	00H	
	Conversion value setting register (DACS0, DACS1)	00H	
Real-time output port	Mode register (RTPM)	00H	
	Control register (RTPC)	00H	
	Buffer register (RTBL, RTBH)	00H	
ROM correction ^(Note)	Correction address register (CORAD0, CORAD1)	0000H	
	Correction control register (CORCN)	00H	
Interrupt	Request flag register (IF0L, IF0H, IF1L)	00H	
	Mask flag register (MK0L, MK0H, MK1L)	FFH	
	Priority specify flag register (PR0L, PR0H, PR1L)	FFH	
	External interrupt mode register (INTM0, INTM1)	00H	
	Key return mode register (KRM)	02H	
	Sampling clock select register (SCS)	00H	

Note Provided only in the μ PD78058, 78058Y, 78P058, 78P058Y.

CHAPTER 25 ROM CORRECTION

25.1 ROM Correction Functions

The μ PD78058, 78058Y subseries can replace part of a program in the mask ROM with a program in the internal expansion RAM.

Instruction bugs found in the mask ROM can be avoided, and program flow can be changed by using the ROM correction.

The ROM correction can correct two places (max.) of the internal ROM (program).

Caution The ROM correction cannot be emulated by the in-circuit emulator (IE-78000-R, IE-78000-R-A, IE-78K0-NS, IE-78001-R-A).

25.2 ROM Correction Configuration

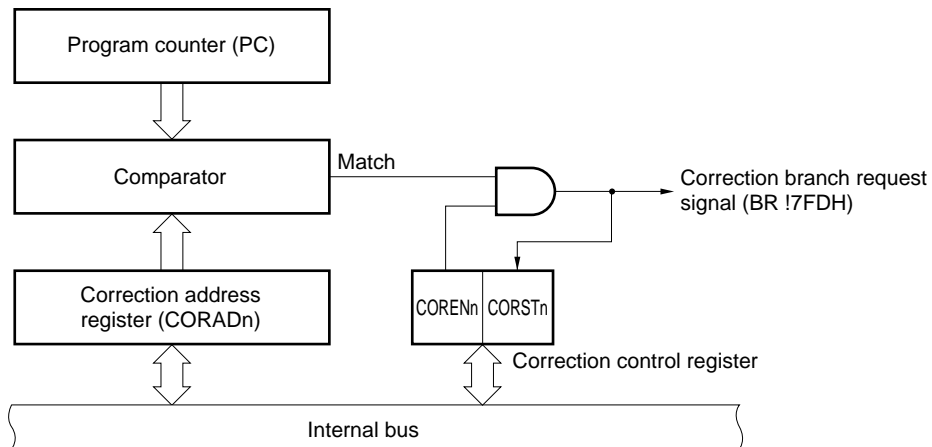
The ROM correction is executed by the following hardware.

Table 25-1. ROM Correction Configuration

Item	Configuration
Register	Correction address registers 0 and 1 (CORAD0, CORAD1)
Control register	Correction control register (CORCN)

Figure 25-1 shows a block diagram of the ROM correction.

Figure 25-1. Block Diagram of ROM Correction



Remark $n = 0, 1$

(1) Correction address registers 0 and 1 (CORAD0, CORAD1)



These registers set the start address (correction address) of the instruction(s) to be corrected in the mask ROM.

The ROM correction corrects two places (max.) of the program. Addresses are set to two registers, CORAD0 and CORAD1. If only one place needs to be corrected, set the address to either of the registers.

CORAD0 and CORAD1 are set with a 16-bit memory manipulation instruction.

$\overline{\text{RESET}}$ input sets CORAD0 and CORAD1 to 0000H.

Figure 25-2. Correction Address Registers 0 and 1 Format

Symbol	15	0	Address	State after reset	R/W
CORAD0			FF38H/FF39H	0000H	R/W
CORAD1			FF3AH/FF3BH	0000H	R/W

Cautions 1. Set the CORAD0 and CORAD1 when bit 1 (COREN0) and bit 3 (COREN1) of the correction control register (CORCN : see Figure 25-3) are 0.

2. Only addresses where operation codes are stored can be set in CORAD0 and CORAD1.

3. Do not set the following addresses to CORAD0 and CORAD1.

- Address value in table area of table reference instruction (CALLT instruction) : 0040H to 007FH
- Address value in vector table area : 0000H to 003FH

(2) Comparator

The comparator always compares the correction address value set in correction address registers 0 and 1 (CORAD0, CORAD1) with the fetch address value. When bit 1 (COREN0) or bit 3 (COREN1) of the correction control register (CORCN) is 1 and the correction address matches the fetch address value, the correction branch request signal (BR !F7FDH) is generated from the ROM correction circuit.

25.3 ROM Correction Control Registers

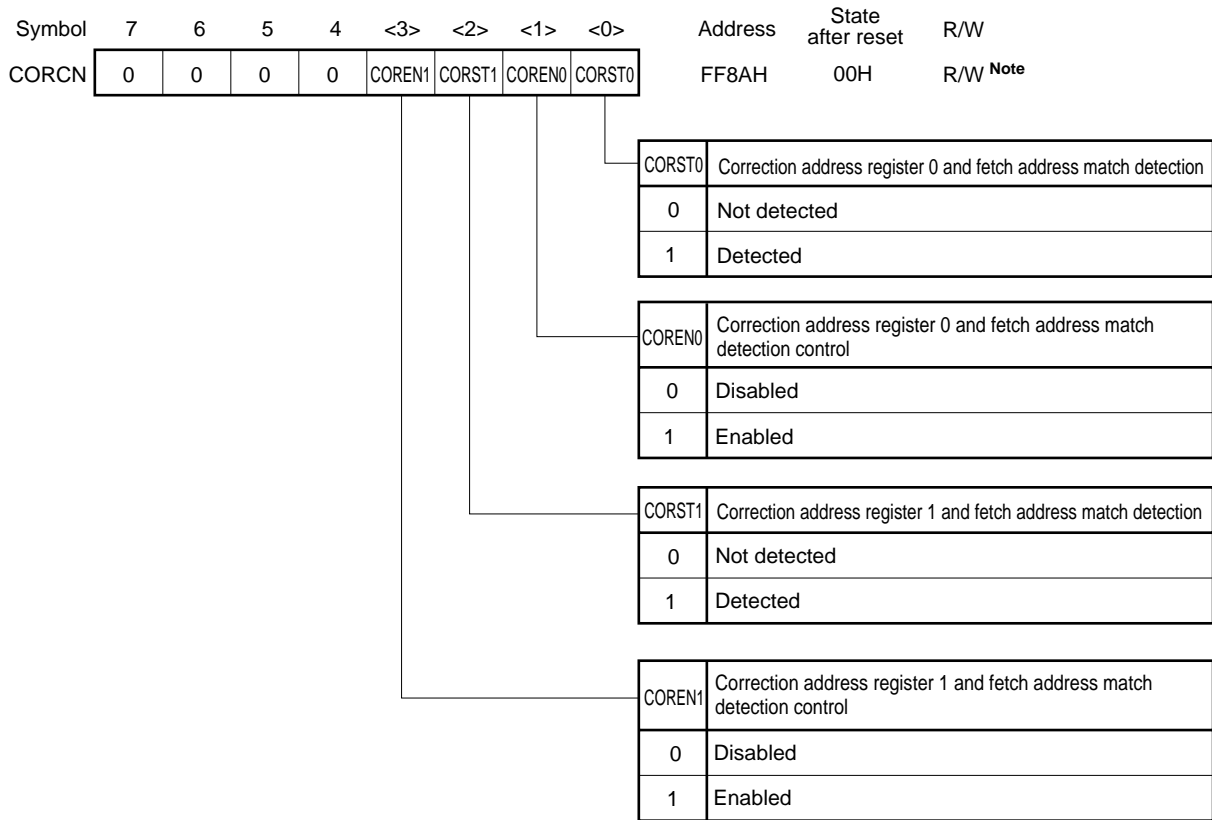
The ROM correction is controlled with the correction control register (CORCN).

(1) Correction control register (CORCN)

This register controls whether or not the correction branch request signal is generated when the fetch address matches the correction address set in correction address registers 0 and 1. The correction control register consists of correction enable flags (COREN0, COREN1) and correction status flags (CORST0, CORST1). The correction enable flags enable or disable the comparator match detection signal, and correction status flags show the values are matched. CORCN is set with a 1-bit or 8-bit memory manipulation instruction.

$\overline{\text{RESET}}$ input sets CORCN to 00H.

Figure 25-3. Correction Control Register Format



Note Bits 0 and 2 are read-only bits.

25.4 ROM Correction Application

- (1) Store the correction address and instruction after correction (patch program) to nonvolatile memory (such as EEPROM™) outside the microcontroller.

When two places should be corrected, store the branch destination judgment program as well. The branch destination judgment program checks which one of the addresses set to CORAD0 or CORAD1 generates the correction branch.

Figure 25-4. Storing Example to EEPROM (when one place is corrected)

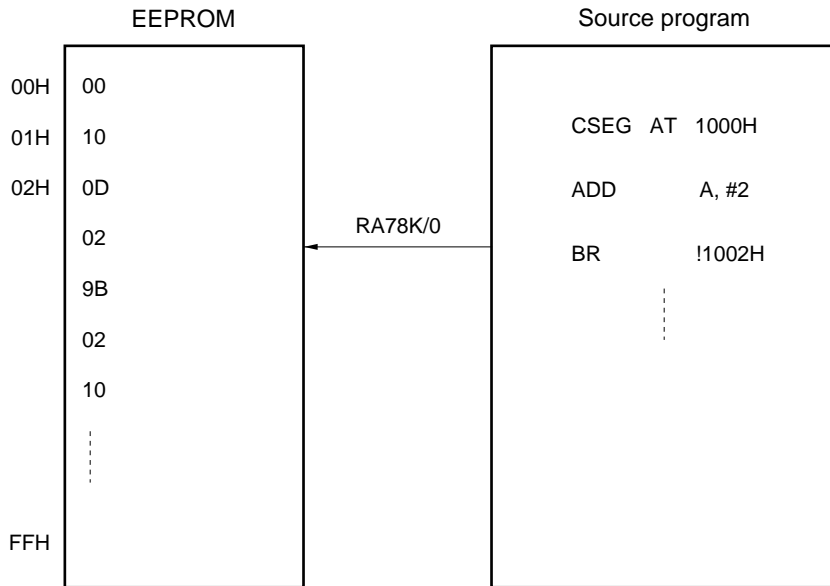
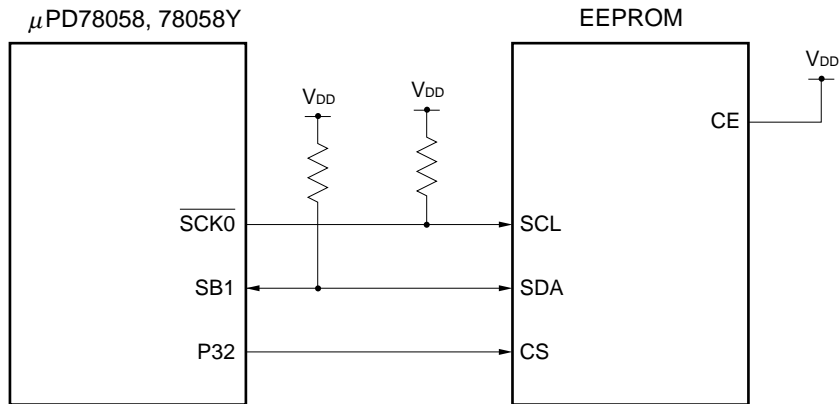
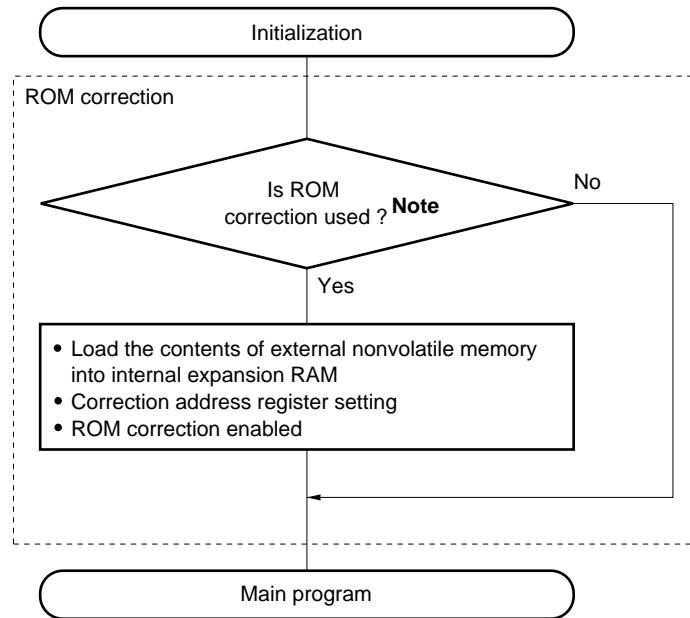


Figure 25-5. Connecting Example with EEPROM (using 2-wire serial I/O mode)



- (2) Assemble in advance the initialization routine as shown in Figure 25-6 to correct the program.

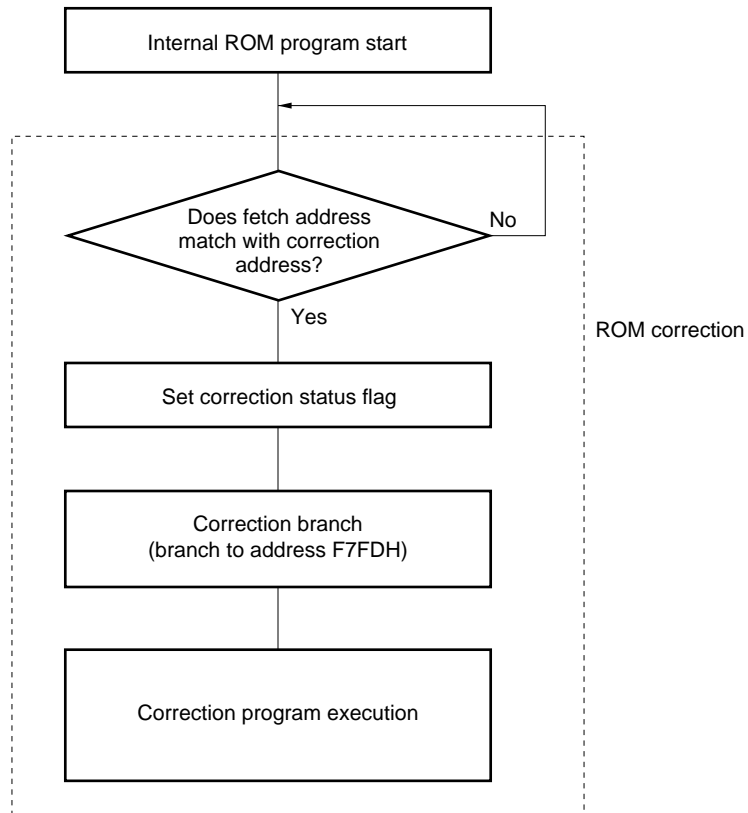
Figure 25-6. Initialization Routine



Note Whether the ROM correction is used or not should be judged by the port input level. For example, when the P20 input level is high, the ROM correction is used, otherwise, it is not used.

- (3) After reset, store the contents that have been previously stored in the external nonvolatile memory with initialization routine for ROM correction of the user to internal expansion RAM (see Figure 25-6). Set the start address of the instruction to be corrected to CORAD0 and CORAD1, and set bits 1 and 3 (COREN0, COREN1) of the correction control register (CORCN) to 1.
- (4) Set the entire-space branch instruction (BR !addr16) to the specified address (F7FDH) of the internal expansion RAM with the main program.
- (5) After the main program is started, the fetch address value and the values set in CORAD0 and CORAD1 are always compared by the comparator in the ROM correction circuit. When these values match, the correction branch request signal is generated. Simultaneously the corresponding correction status flag (CORST0 or CORST1) is set to 1.
- (6) Branch to the address F7FDH by the correction branch request signal.
- (7) Branch to the internal expansion RAM address set with the main program by the entire-space branch instruction of the address F7FDH.
- (8) When one place is corrected, the correction program is executed. When two places are corrected, the correction status flag is checked with the branch destination judgment program, and branches to the correction program.

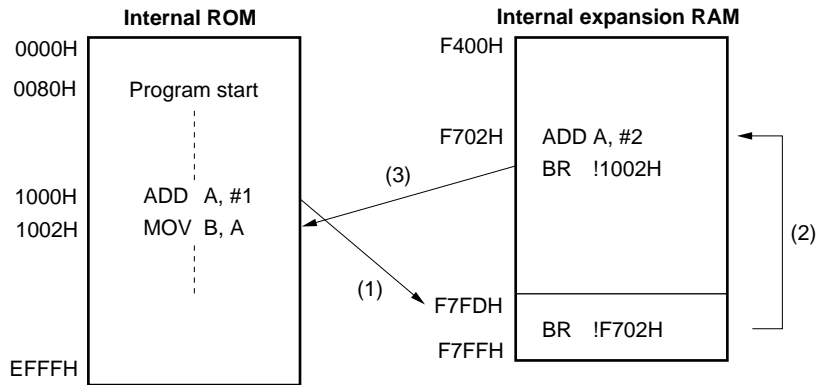
Figure 25-7. ROM Correction Operation



25.5 ROM Correction Example

The example of ROM correction when the instruction at address 1000H “ADD A, #1” is changed to “ADD A, #2” is as follows.

Figure 25-8. ROM Correction Example

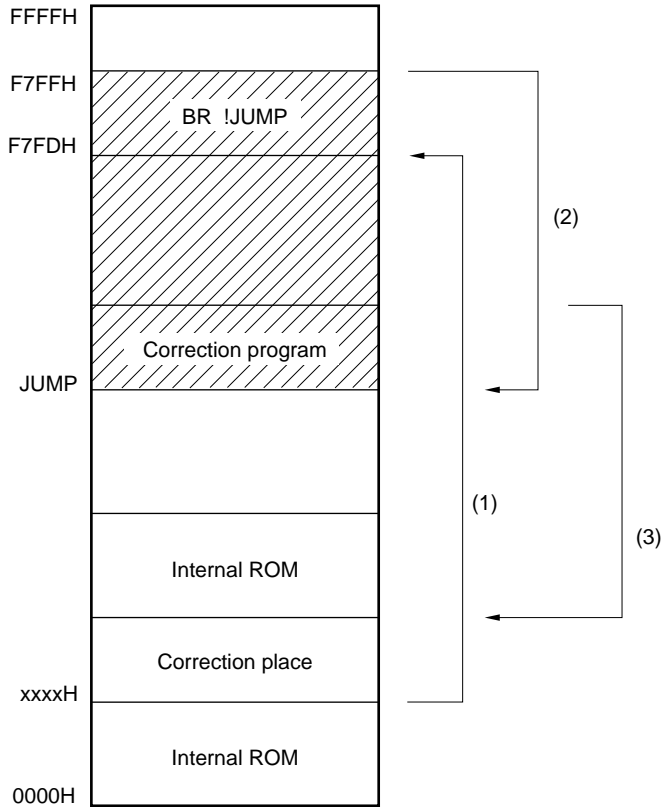


- (1) Branches to address F7FDH when the preset value 1000H in the correction address register matches the fetch address value after the main program is started.
- (2) Branches to any address (address F702H in this example) by setting the entire-space branch instruction (BR !addr16) to address F7FDH with the main program.
- (3) Returns to the internal ROM program after executing the substitute instruction ADD A, #2.

25.6 Program Execution Flow

Figures 25-9 and 25-10 show the program transition diagrams when the ROM correction is used.

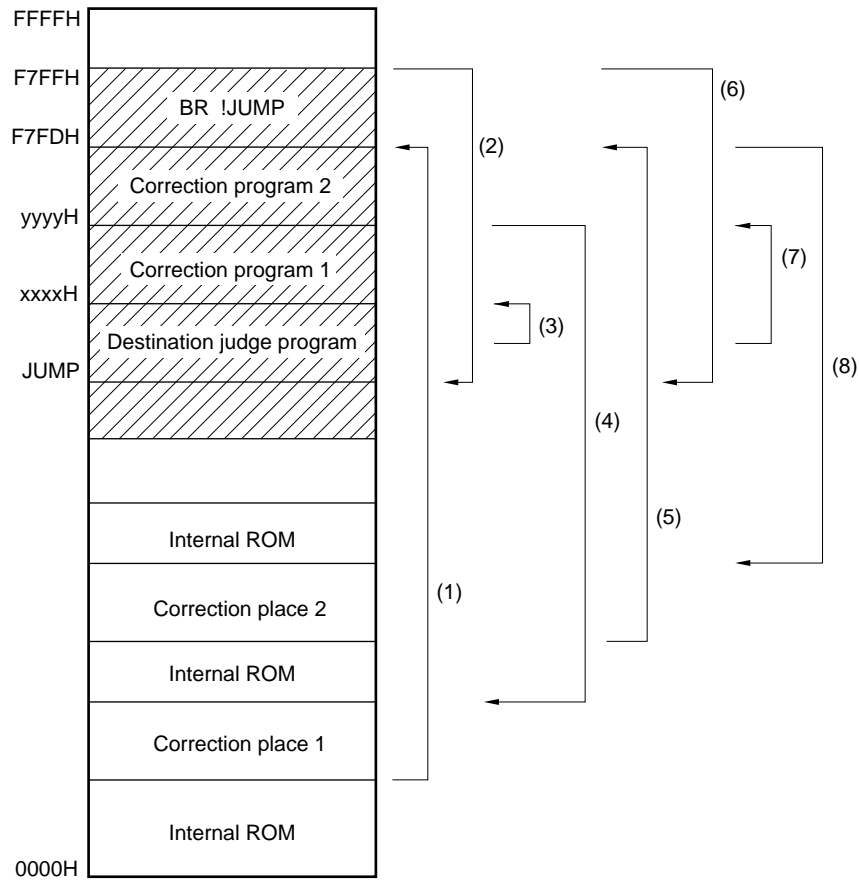
Figure 25-9. Program Transition Diagram (when one place is corrected)



- (1) Branches to address F7FDH when fetch address matches correction address
- (2) Branches to correction program
- (3) Returns to internal ROM program

Remark Area filled with diagonal lines : Internal expansion RAM
 JUMP : Correction program start address

Figure 25-10. Program Transition Diagram (when two places are corrected)



- (1) Branches to address F7FDH when fetch address matches correction address
- (2) Branches to branch destination judgment program
- (3) Branches to correction program 1 by branch destination judgment program (BTCLR !CORST0, \$xxxxH)
- (4) Returns to internal ROM program
- (5) Branches to address F7FDH when fetch address matches correction address
- (6) Branches to branch destination judgment program
- (7) Branches to correction program 2 by branch destination judgment program (BTCLR !CORST1, \$yyyyH)
- (8) Returns to internal ROM program

Remark Area filled with diagonal lines : Internal expansion RAM
 JUMP : Destination judge program start address

25.7 Cautions on ROM Correction

- (1) Address values set in correction address registers 0 and 1 (CORAD0, CORAD1) must be addresses where instruction codes are stored.
- (2) Correction address registers 0 and 1 (CORAD0, CORAD1) should be set when the correction enable flag (COREN0, COREN1) is 0 (when the correction branch is in disabled state). If address is set to CORAD0 or CORAD1 when COREN0 or COREN1 is 1 (when the correction branch is in enabled state), the correction branch may start with the different address from the set address value.
- (3) Do not set the address value of instruction immediately after the instruction that sets the correction enable flag (COREN0, COREN1) to 1, to correction address register 0 or 1 (CORAD0, CORAD1) ; the correction branch may not start.
- (4) Do not set the address value in table area of table reference instruction (CALLT instruction) (0040H to 007FH), and the address value in vector table area (0000H to 003FH) to correction address registers 0 and 1 (CORAD0, CORAD1).
- (5) Do not set two addresses immediately after the instructions shown below to correction address registers 0 and 1 (CORAD0, CORAD1). (that is, when the mapped terminal address of these instructions is N, do not set the address values of N+1 and N+2.)
 - RET
 - RETI
 - RETB
 - BR \$addr16
 - STOP
 - HALT

CHAPTER 26 μ PD78P054, 78P058

The μ PD78054, 78054Y subseries include the μ PD78P054, 78P058, 78P058Y as PROM versions.

For purposes of simplification, in this chapter, the description of the μ PD78P058 applies to both the μ PD78P058 and 78P058Y. Similarly, the μ PD78052, 78053, 78054, 78055, 78056, and 78058 are treated as the representative models of the mask ROM products.

The μ PD78P054, 78P058 replace the internal mask ROM of the μ PD78054, 78058 with one-time PROM or EPROM. Table 26-1 lists the differences among the μ PD78P054, 78P058 and the mask ROM versions. Table 26-2 lists the differences between the μ PD78P054 and the μ PD78P058.

Table 26-1. Differences between μ PD78P054, 78P058 and Mask ROM Versions

Item	μ PD78P054, 78P058	Mask ROM version
Internal ROM structure	One-time PROM/EPROM	Mask ROM
Internal ROM capacity	μ PD78P054: 32 Kbytes μ PD78P058: 60 Kbytes	μ PD78052: 16 Kbytes μ PD78053: 24 Kbytes μ PD78054: 32 Kbytes μ PD78055: 40 Kbytes μ PD78056: 48 Kbytes μ PD78058: 60 Kbytes
Internal high-speed RAM capacity	1024 bytes	μ PD78052: 512 bytes μ PD78053: 1024 bytes μ PD78054: 1024 bytes μ PD78055: 1024 bytes μ PD78056: 1024 bytes μ PD78058: 1024 bytes
Internal expansion RAM capacity	μ PD78P054: None μ PD78P058: 1024 bytes	μ PD78052: None μ PD78053: None μ PD78054: None μ PD78055: None μ PD78056: None μ PD78058: 1024 bytes
Changing internal ROM and internal high-speed RAM capacities with memory size switching register	Enable ^{Note 1}	Disable
Changing of internal expansion RAM capacity by internal expansion RAM size switching register	Enable with μ PD78P058 only ^{Note 2}	Disable
IC pin	None	Available
V _{PP} pin	Available	None
Mask option with on-chip pull-up resistor for P60 to P63 pins	None	None
Electrical characteristics	Refer to the separate Data Sheet.	

- Notes**
1. The internal ROM and internal high-speed RAM capacities are set as follows by $\overline{\text{RESET}}$ input:
Internal PROM: 32K bytes (μ PD78P054), 60K bytes (μ PD78P058)
Internal high-speed RAM: 1024 bytes
 2. The internal expansion RAM is set to 1024 bytes by $\overline{\text{RESET}}$ input.

Caution The noise immunity and noise radiation differ between PROM versions and mask ROM versions. When considering replacement of PROM versions with mask ROM versions in the stage between test production and mass production, evaluate thoroughly with CS products (not ES products) of the mask ROM versions.

- Remarks**
1. The μ PD78P054 is a PROM model corresponding to the μ PD78052, 78053, and 78054.
The μ PD78P058 is a PROM model corresponding to the μ PD78055, 78056, and 78058.
 2. Only the μ PD78058 and 78P058 are provided with an internal expansion RAM size switching register.

Table 26-2. Differences between μ PD78P054 and 78P058

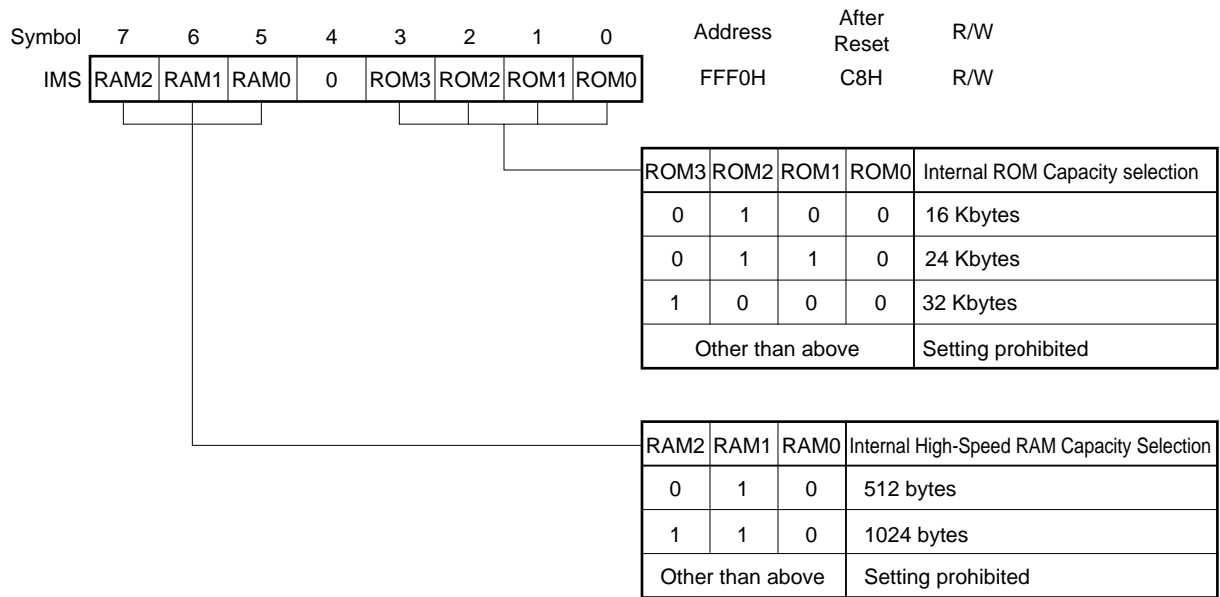
Item	μ PD78P054	μ PD78P058
Internal PROM	32 Kbytes	60 Kbytes
Internal expansion RAM	Not provided	1024 bytes
Internal expansion RAM size switching register	Not provided	Provided

26.1 Memory Size Switching Register (μ PD78P054)

The μ PD78P054 allows users to define its internal ROM and high-speed RAM sizes using the memory size switching register (IMS), so that the same memory mapping as that of a mask ROM version with a different-size internal ROM and high-speed RAM is possible. IMS is set with an 8-bit memory manipulation instruction.

$\overline{\text{RESET}}$ input sets IMS to C8H.

Figure 26-1. Memory Size Switching Register Format (μ PD78P054)



The IMS settings to give the same memory map as mask ROM versions are shown in Table 26-3.

Table 26-3. Examples of Memory Size Switching Register Settings (μ PD78P054)

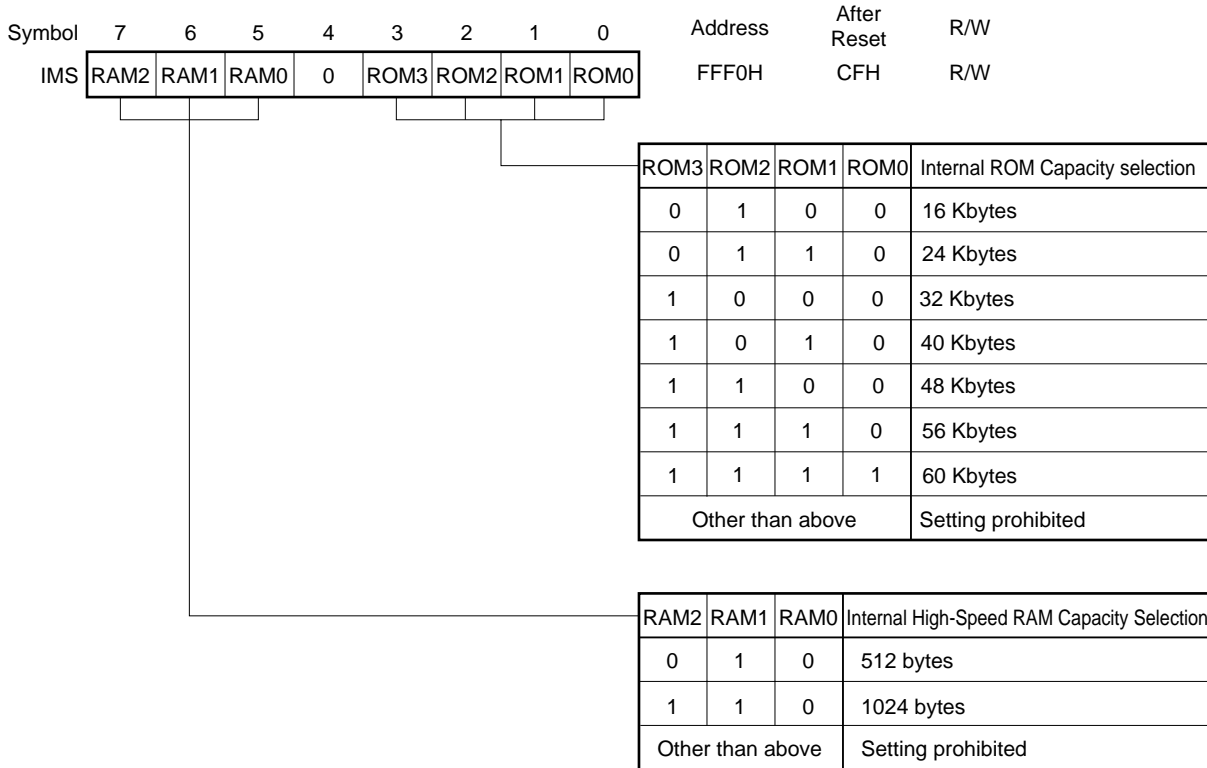
Relevant Mask ROM Version	IMS Setting
μ PD78052	44H
μ PD78053	C6H
μ PD78054	C8H

26.2 Memory Size Switching Register (μ PD78P058)

The μ PD78P058 allows users to define its internal ROM and high-speed RAM sizes using the memory size switching register (IMS), so that the same memory mapping as that of a mask ROM version with a different-size internal ROM and high-speed RAM is possible. IMS is set with an 8-bit memory manipulation instruction.

$\overline{\text{RESET}}$ input sets IMS to CFH.

Figure 26-2. Memory Size Switching Register Format (μ PD78P058)



The IMS settings to give the same memory map as mask ROM versions are shown in Table 26-4.

Table 26-4. Examples of Memory Size Switching Register Settings (μ PD78P058)

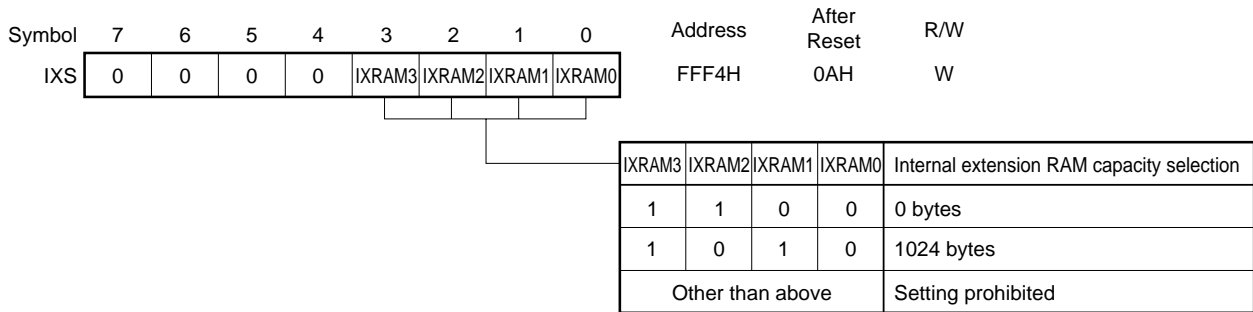
Relevant Mask ROM Version	IMS Setting
μ PD78052, 78052Y	44H
μ PD78053, 78053Y	C6H
μ PD78054, 78054Y	C8H
μ PD78055, 78055Y	CAH
μ PD78056, 78056Y	CCH
μ PD78058, 78058Y	CFH

26.3 Internal Expansion RAM Size Switching Register

The μ PD78P058 allows users to define its internal expansion RAM size using the internal expansion RAM size switching register (IXS), so that the same memory mapping as that of a mask ROM version with a different-size internal expansion RAM is possible. The IXS is set by an 8-bit memory manipulation instruction.

$\overline{\text{RESET}}$ signal input sets IXS to 0AH.

Figure 26-3. Internal Expansion RAM Size Switching Register Format



The value in the IXS that has the identical memory map to the mask ROM versions is given in Table 26-5.

Table 26-5. Value Set to the Internal Expansion RAM Size Switching Register

Pertinent mask ROM versions	Value set to IXS
μ PD78052, 78052Y	0CH
μ PD78053, 78053Y	
μ PD78054, 78054Y	
μ PD78055, 78055Y	
μ PD78056, 78056Y	
μ PD78058, 78058Y	0AH

Remark If a program for the μ PD78P058 or 78P058Y which includes “MOV IXS, #0CH” is implemented with the μ PD78055, 78055Y, 78056, or 78056Y, this instruction is ignored and causes no malfunction.

26.4 PROM Programming

The μ PD78P054 and 78P058 incorporate a 32-Kbyte and 60-Kbyte PROM as program memory, respectively. To write a program into the μ PD78P054 or 78P058 PROM, make the device enter the PROM programming mode by setting the levels of the V_{PP} and $\overline{\text{RESET}}$ pins as specified. For the connection of unused pins, see paragraph (2) “PROM programming mode” in section 1.5 or 2.5 Pin Configuration (Top View).

Caution In case of the μ PD78P054, write the program in the range of addresses 0000H to 7FFFH (specify the last address as 7FFFH.)

In case of the μ PD78P058, write the program in the range of addresses 0000H to EFFFH (specify the last address as EFFFH.)

The program cannot be correctly written by a PROM programmer which does not have a write address specification function.

26.4.1 Operating modes

When +5 V or +12.5 V is applied to the V_{PP} pin and a low-level signal is applied to the $\overline{\text{RESET}}$ pin, the μ PD78P054 and μ PD78P058 are set to the PROM programming mode. This is one of the operating modes shown in Table 26-6 below according to the setting of the $\overline{\text{CE}}$, $\overline{\text{OE}}$, and $\overline{\text{PGM}}$ pins.

The PROM contents can be read by setting the read mode.

Table 26-6. PROM Programming Operating Modes

Operating mode	Pin	$\overline{\text{RESET}}$	V_{PP}	V_{DD}	$\overline{\text{CE}}$	$\overline{\text{OE}}$	$\overline{\text{PGM}}$	D0-D7
Page data latch	L		+12.5 V	+6.5 V	H	L	H	Data input
Page write					H	H	L	High impedance
Byte write					L	H	L	Data input
Program verify					L	L	H	Data output
Program inhibit					×	H	H	High impedance
					×	L	L	
Read		+5 V	+5V	L	L	H	Data output	
Output disabled				L	H	×	High impedance	
Standby				H	×	×	High impedance	

Remark ×: L or H

(1) Read mode

Read mode is set by setting $\overline{\text{CE}}$ to L and $\overline{\text{OE}}$ to L.

(2) Output disable mode

If $\overline{\text{OE}}$ is set to H, data output becomes high impedance and the output disable mode is set.

Therefore, if multiple μ PD78P054s or 78P058s are connected to the data bus, data can be read from any one device by controlling the $\overline{\text{OE}}$ pin.

(3) Standby mode

Setting \overline{CE} to H sets the standby mode.

In this mode, data output becomes high impedance irrespective of the status of \overline{OE} .

(4) Page data latch mode

Setting \overline{CE} to H, \overline{PGM} to H, and \overline{OE} to L at the start of the page write mode sets the page data latch mode.

In this mode, 1-page 4-byte data is latched in the internal address/data latch circuit.

(5) Page write mode

After a 1-page 4-byte address and data are latched by the page data latch mode, a page write is executed by applying a 0.1-ms program pulse (active-low) to the \overline{PGM} pin while $\overline{CE}=H$ and $\overline{OE}=H$. After this, program verification can be performed by setting \overline{CE} to L and \overline{OE} to L.

If programming is not performed by one program pulse, repeated write and verify operations are executed X times ($X \leq 10$).

(6) Byte write mode

A byte write is executed by applying a 0.1-ms program pulse (active-low) to the \overline{PGM} pin while $\overline{CE}=L$ and $\overline{OE}=H$. After this, program verification can be performed by setting \overline{OE} to L.

If programming is not performed by one program pulse, repeated write and verify operations are executed X times ($X \leq 10$).

(7) Program verify mode

Setting \overline{CE} to L, \overline{PGM} to H, and \overline{OE} to L sets the program verify mode.

After writing is performed, this mode should be used to check whether the data was written correctly.

(8) Program inhibit mode

The program inhibit mode is used when the \overline{OE} pins, V_{PP} pins and pins D0 to D7 of multiple μ PD78P054s or 78P058s are connected in parallel and any one of these devices must be written to.

The page write mode or byte write mode described above is used to perform a write. At this time, the write is not performed on the device which has the \overline{PGM} pin driven high.

26.4.2 PROM write procedure

Figure 26-4. Page Program Mode Flowchart

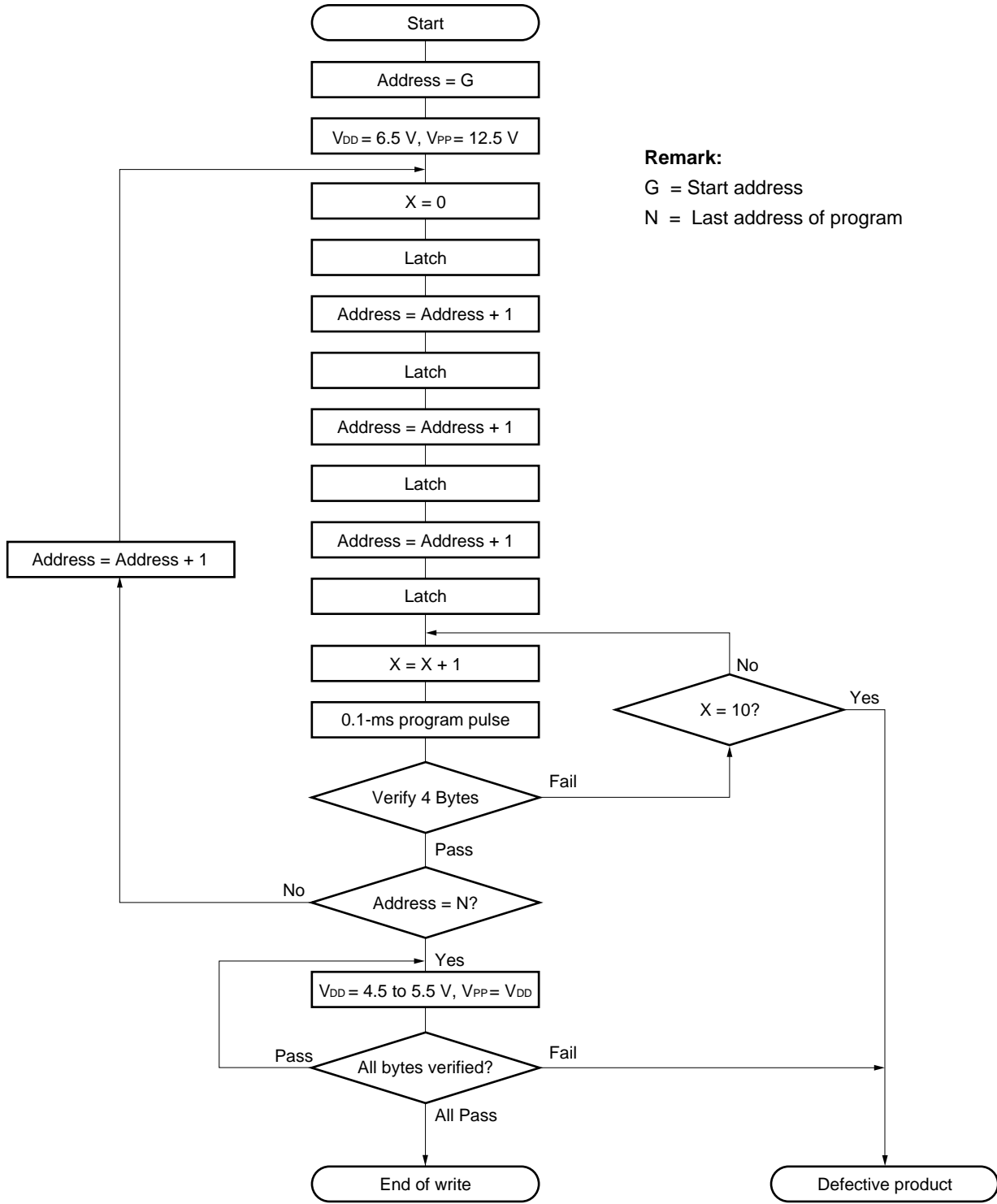


Figure 26-5. Page Program Mode Timing

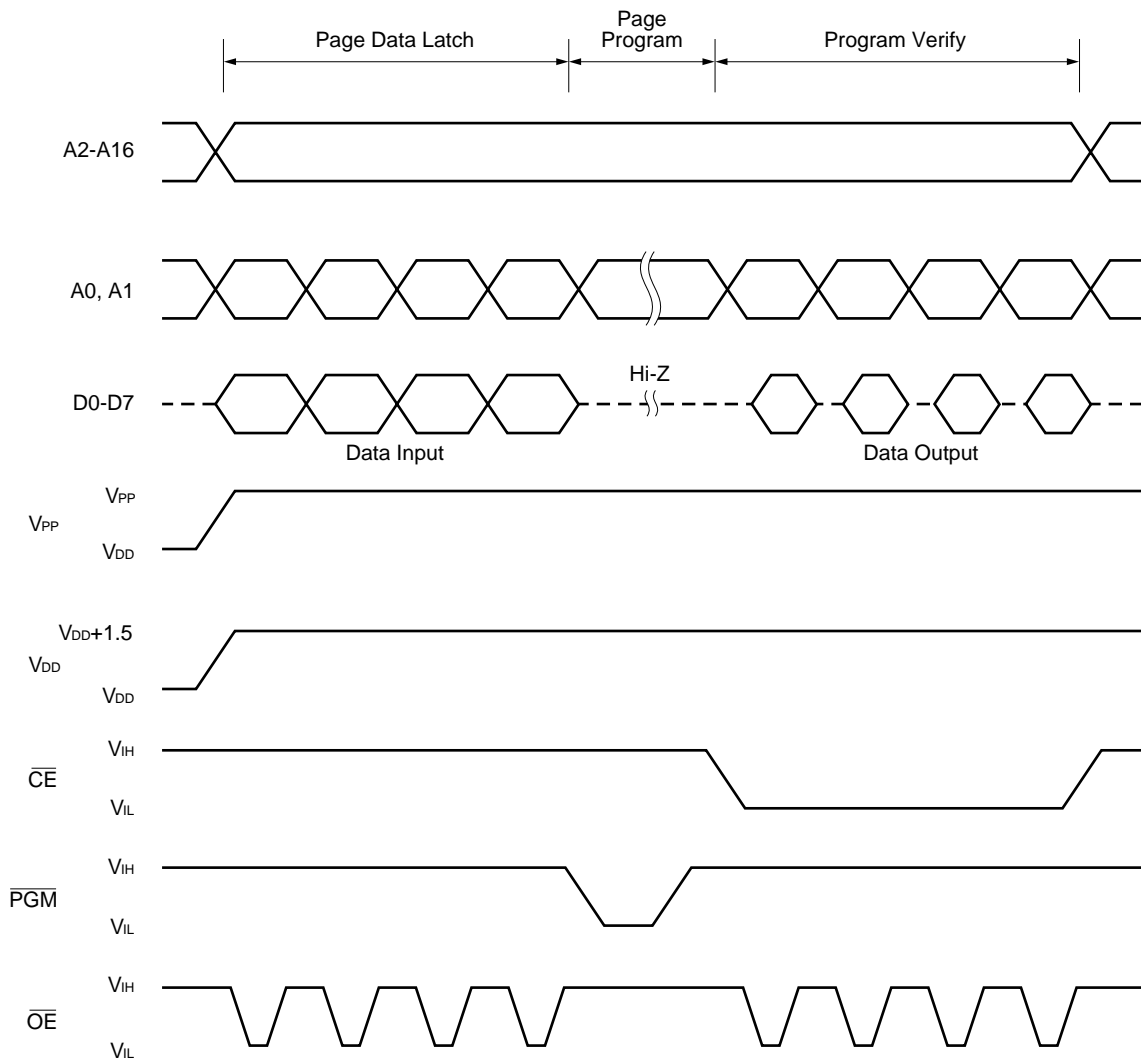


Figure 26-6. Byte Program Mode Flowchart

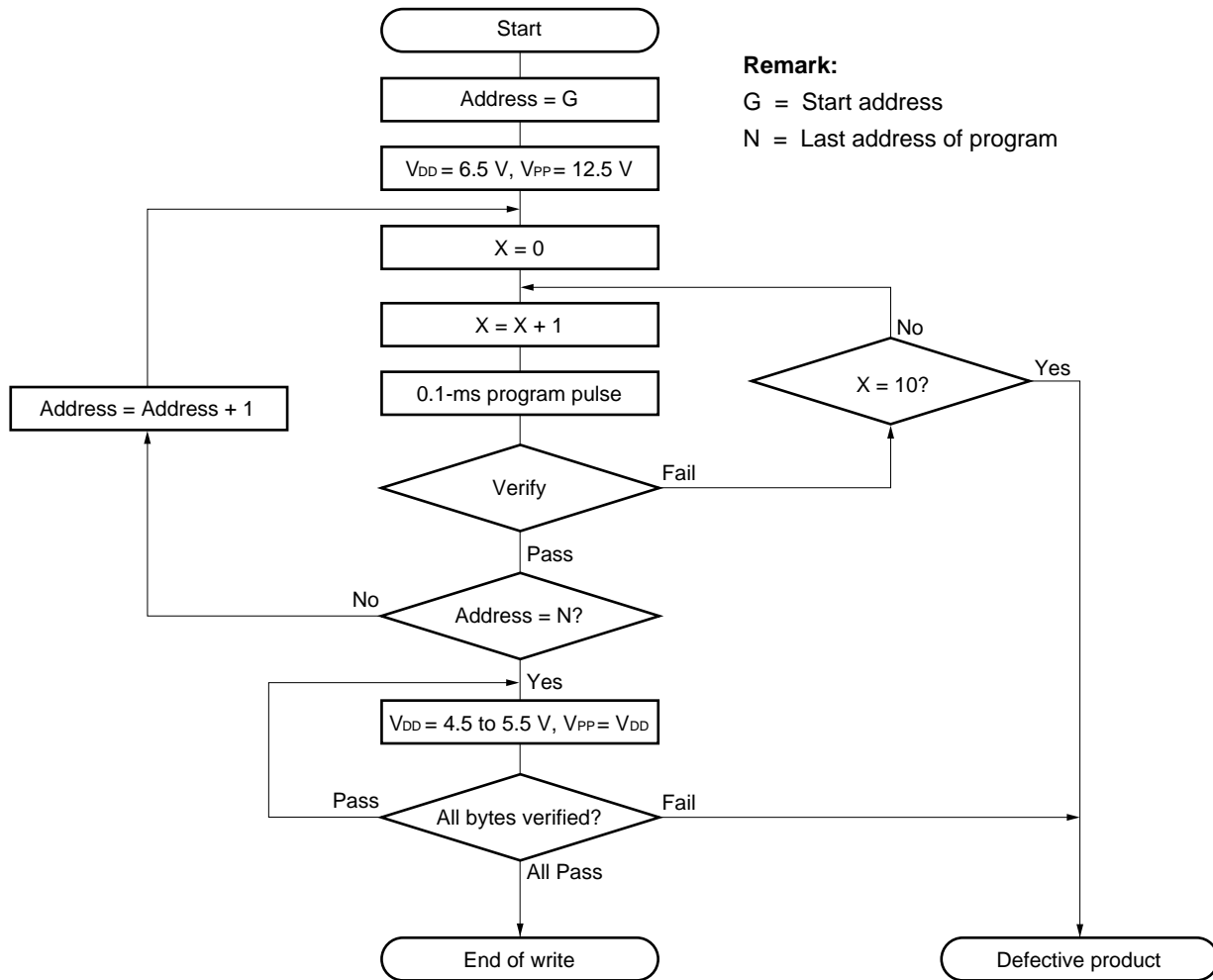
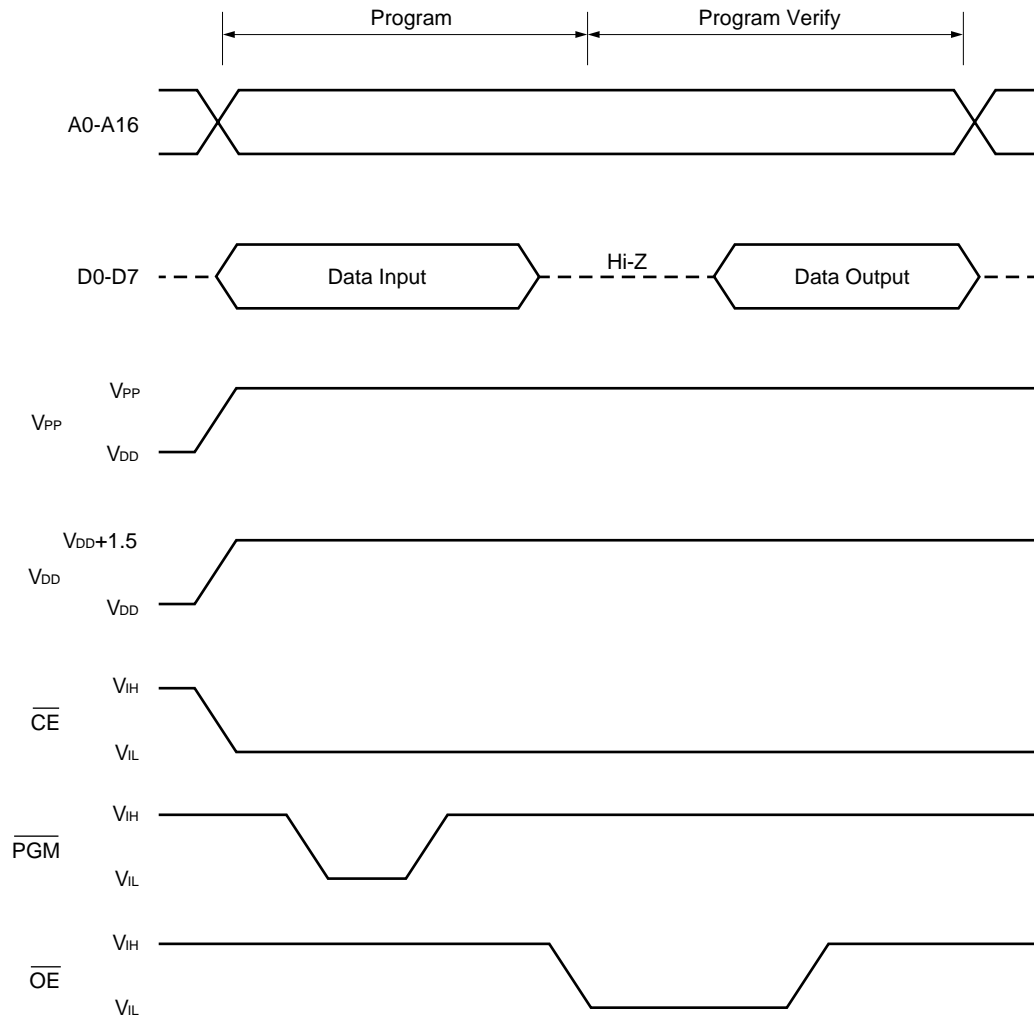


Figure 26-7. Byte Program Mode Timing



- Cautions**
1. Be sure to apply V_{DD} before applying V_{PP} , and remove it after removing V_{PP} .
 2. V_{PP} must not exceed +13.5 V including overshoot voltage.
 3. Disconnecting/inserting the device from/to the on-board socket while +12.5 V is being applied to the V_{PP} pin may have an adverse effect on device reliability.

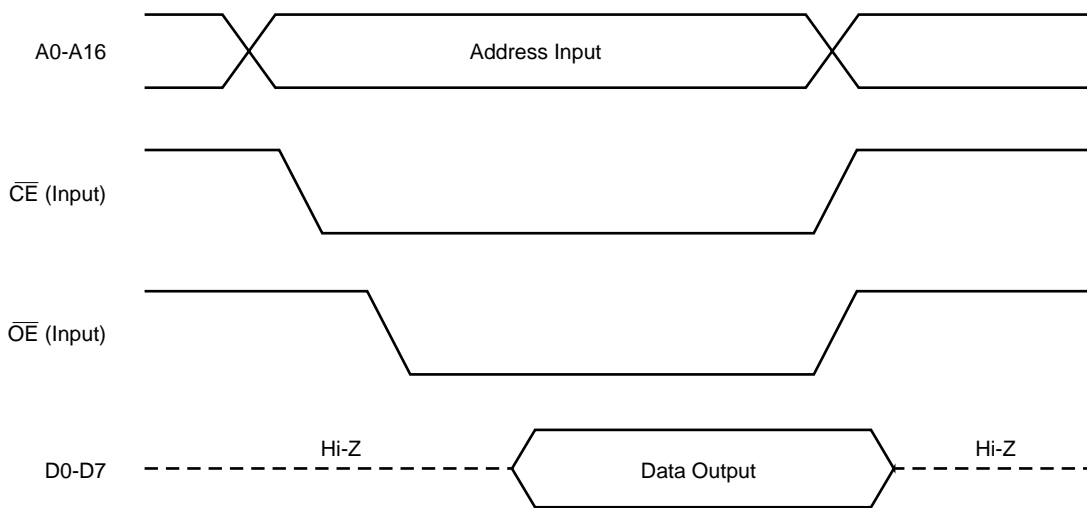
26.4.3 PROM reading procedure

PROM contents can be read onto the external data bus (D0 to D7) using the following procedure.

- (1) Fix the $\overline{\text{RESET}}$ pin low, and supply +5 V to the V_{PP} pin. Unused pins are handled as shown in paragraph, **(2) "PROM programming mode"** in section 1.5 or 2.5 **Pin Configuration (Top View)**.
- (2) Supply +5 V to the V_{DD} and V_{PP} pins.
- (3) Input the address of data to be read to pins A0 through A16.
- (4) Read mode is entered.
- (5) Data is output to pins D0 through D7.

The timing for steps (2) through (5) above is shown in Figure 26-8.

Figure 26-8. PROM Read Timing



26.5 Erasure Procedure (μ PD78P054KK-T and 78P058KK-T Only)

With the μ PD78P054KK-T or 78P058KK-T, it is possible to erase (or set all contents to FFH) the data contents written in the program memory, and rewrite the memory.

The data can be erased by exposing the window to light with a wavelength of approximately 400 nm or shorter. Typically, data is erased by 254-nm ultraviolet light rays. The minimum lighting level to completely erase the written data is shown below.

- UV intensity \times exposure time: 30 W.s/cm² or more
- Exposure time: 40 minutes or more (using a 12 mW/cm² ultraviolet lamp. A longer exposure time may be required in case of deterioration of the ultraviolet lamp or dirt on the package window).

When erasing written data, remove any filter on the window and place the device within 2.5 cm of the lamp tube.

26.6 Opaque Film Masking the Window (μ PD78P054KK-T and 78P058KK-T Only)

To prevent unintentional erasure of the EPROM contents by light and to prevent internal circuits from malfunction due to light coming in through the erasure window, mask the window with opaque film after writing the EPROM.

26.7 Screening of One-Time PROM Versions

One-time PROM versions (μ PD78P054GC-3B9, 78P054GC-8BT, 78P054GK-BE9, 78P058GC-8BT, and 78P058YGC-8BT) cannot be fully tested by NEC before shipment due to the structure of one-time PROM. Therefore, after users have written data into the PROM, screening should be implemented by user: that is, store devices at high temperature for one day as specified below, and verify their contents after the devices have returned to room temperature.

Storage Temperature	Storage Time
125°C	24 hours

For users who do not wish to implement screening by themselves, NEC provides such users with a charged service in which NEC performs a series of processes from writing one-time PROMs and screening them to verifying their contents for users by request. The PROM version devices which provide this service are called QTOP™ microcontrollers. For details, please consult an NEC sales representative.

[MEMO]

CHAPTER 27 INSTRUCTION SET

This chapter describes each instruction set of the μ PD78054 and 78054Y subseries as list table. For details of its operation and operation code, refer to the separate document “**78K/0 Series User’s Manual, Instruction (U12326E)**.”

27.1 Legends Used in Operation List

27.1.1 Operand identifiers and description methods

Operands are described in “Operand” column of each instruction in accordance with the description method of the instruction operand identifier (refer to the assembler specifications for detail). When there are two or more description methods, select one of them. Alphabetic letters in capitals and symbols, #, !, \$ and [] are key words and must be described as they are. Each symbol has the following meaning.

- # : Immediate data specification
- ! : Absolute address specification
- \$: Relative address specification
- [] : Indirect address specification

In the case of immediate data, describe an appropriate numeric value or a label. When using a label, be sure to describe the #, !, \$, and [] symbols.

For operand register identifiers, r and rp, either function names (X, A, C, etc.) or absolute names (names in parentheses in the table below, R0, R1, R2, etc.) can be used for description.

Table 27-1. Operand Identifiers and Description Methods

Identifier	Description Method
r	X (R0), A (R1), C (R2), B (R3), E (R4), D (R5), L (R6), H (R7),
rp	AX (RP0), BC (RP1), DE (RP2), HL (RP3)
sfr	Special-function register symbol ^{Note}
sfrp	Special-function register symbol (16-bit manipulatable register even addresses only) ^{Note}
saddr	FE20H-FF1FH Immediate data or labels
saddrp	FE20H-FF1FH Immediate data or labels (even address only)
addr16	0000H-FFFFH Immediate data or labels (Only even addresses for 16-bit data transfer instructions)
addr11	0800H-0FFFH Immediate data or labels
addr5	0040H-007FH Immediate data or labels (even address only)
word	16-bit immediate data or label
byte	8-bit immediate data or label
bit	3-bit immediate data or label
RBn	RB0 to RB3

Note Addresses from FFD0H to FFDFH cannot be accessed with these operands.

Remark For special-function register symbols, refer to **Table 5-6. Special-Function Register List**.

27.1.2 Description of “operation” column

A	: A register; 8-bit accumulator
X	: X register
B	: B register
C	: C register
D	: D register
E	: E register
H	: H register
L	: L register
AX	: AX register pair; 16-bit accumulator
BC	: BC register pair
DE	: DE register pair
HL	: HL register pair
PC	: Program counter
SP	: Stack pointer
PSW	: Program status word
CY	: Carry flag
AC	: Auxiliary carry flag
Z	: Zero flag
RBS	: Register bank select flag
IE	: Interrupt request enable flag
NMIS	: Non-maskable interrupt servicing flag
()	: Memory contents indicated by address or register contents in parentheses
× _H , × _L	: Higher 8 bits and lower 8 bits of 16-bit register
^	: Logical product (AND)
∨	: Logical sum (OR)
⊕	: Exclusive logical sum (exclusive OR)
—	: Inverted data
addr16	: 16-bit immediate data or label
jdisp8	: Signed 8-bit data (displacement value)

27.1.3 Description of “flag operation” column

(Blank)	: Not affected
0	: Cleared to 0
1	: Set to 1
×	: Set/cleared according to the result
R	: Previously saved value is restored

27.2 Operation List

Instruction Group	Mnemonic	Operands	Byte	Clock		Operation	Flag				
				Note 1	Note 2		Z	AC	CY		
8-bit data transfer	MOV	r, #byte	2	4	–	$r \leftarrow \text{byte}$					
		saddr, #byte	3	6	7	$(\text{saddr}) \leftarrow \text{byte}$					
		sfr, #byte	3	–	7	$\text{sfr} \leftarrow \text{byte}$					
		A, r	Note 3	1	2	–	$A \leftarrow r$				
		r, A	Note 3	1	2	–	$r \leftarrow A$				
		A, saddr		2	4	5	$A \leftarrow (\text{saddr})$				
		saddr, A		2	4	5	$(\text{saddr}) \leftarrow A$				
		A, sfr		2	–	5	$A \leftarrow \text{sfr}$				
		sfr, A		2	–	5	$\text{sfr} \leftarrow A$				
		A, !addr16		3	8	9 + n	$A \leftarrow (\text{addr16})$				
		!addr16, A		3	8	9 + m	$(\text{addr16}) \leftarrow A$				
		PSW, #byte		3	–	7	$\text{PSW} \leftarrow \text{byte}$	x	x	x	
		A, PSW		2	–	5	$A \leftarrow \text{PSW}$				
		PSW, A		2	–	5	$\text{PSW} \leftarrow A$	x	x	x	
		A, [DE]		1	4	5 + n	$A \leftarrow (\text{DE})$				
		[DE], A		1	4	5 + m	$(\text{DE}) \leftarrow A$				
		A, [HL]		1	4	5 + n	$A \leftarrow (\text{HL})$				
		[HL], A		1	4	5 + m	$(\text{HL}) \leftarrow A$				
		A, [HL + byte]		2	8	9 + n	$A \leftarrow (\text{HL} + \text{byte})$				
		[HL + byte], A		2	8	9 + m	$(\text{HL} + \text{byte}) \leftarrow A$				
		A, [HL + B]		1	6	7 + n	$A \leftarrow (\text{HL} + \text{B})$				
		[HL + B], A		1	6	7 + m	$(\text{HL} + \text{B}) \leftarrow A$				
		A, [HL + C]		1	6	7 + n	$A \leftarrow (\text{HL} + \text{C})$				
		[HL + C], A		1	6	7 + m	$(\text{HL} + \text{C}) \leftarrow A$				
		XCH	A, r	Note 3	1	2	–	$A \leftrightarrow r$			
			A, saddr		2	4	6	$A \leftrightarrow (\text{saddr})$			
			A, sfr		2	–	6	$A \leftrightarrow \text{sfr}$			
			A, !addr16		3	8	10 + n + m	$A \leftrightarrow (\text{addr16})$			
	A, [DE]			1	4	6 + n + m	$A \leftrightarrow (\text{DE})$				
	A, [HL]			1	4	6 + n + m	$A \leftrightarrow (\text{HL})$				
	A, [HL + byte]			2	8	10 + n + m	$A \leftrightarrow (\text{HL} + \text{byte})$				
	A, [HL + B]			2	8	10 + n + m	$A \leftrightarrow (\text{HL} + \text{B})$				
A, [HL + C]			2	8	10 + n + m	$A \leftrightarrow (\text{HL} + \text{C})$					

- Notes**
1. When the internal high-speed RAM area is accessed or instruction with no data access.
 2. When an area except the internal high-speed RAM area is accessed.
 3. Except "r = A"

- Remarks**
1. One instruction clock cycle is one cycle of the CPU clock (f_{CPU}) selected by the processor clock control register (PCC).
 2. This clock cycle applies to internal ROM program.
 3. n is the number of waits when external memory expansion area is read from.
 4. m is the number of waits when external memory expansion area is written to.

Instruction Group	Mnemonic	Operands	Byte	Clock		Operation	Flag		
				Note 1	Note 2		Z	AC	CY
16-bit data transfer	MOVW	rp, #word	3	6	–	rp ← word			
		saddrp, #word	4	8	10	(saddrp) ← word			
		sfrp, #word	4	–	10	sfrp ← word			
		AX, saddrp	2	6	8	AX ← (saddrp)			
		saddrp, AX	2	6	8	(saddrp) ← AX			
		AX, sfrp	2	–	8	AX ← sfrp			
		sfrp, AX	2	–	8	sfrp ← AX			
		AX, rp Note 3	1	4	–	AX ← rp			
		rp, AX Note 3	1	4	–	rp ← AX			
		AX, !addr16	3	10	12 + 2n	AX ← (addr16)			
	!addr16, AX	3	10	12 + 2m	(addr16) ← AX				
XCHW	AX, rp Note 3	1	4	–	AX ↔ rp				
8-bit operation	ADD	A, #byte	2	4	–	A, CY ← A + byte	x	x	x
		saddr, #byte	3	6	8	(saddr), CY ← (saddr) + byte	x	x	x
		A, r Note 4	2	4	–	A, CY ← A + r	x	x	x
		r, A	2	4	–	r, CY ← r + A	x	x	x
		A, saddr	2	4	5	A, CY ← A + (saddr)	x	x	x
		A, !addr16	3	8	9 + n	A, CY ← A + (addr16)	x	x	x
		A, [HL]	1	4	5 + n	A, CY ← A + (HL)	x	x	x
		A, [HL + byte]	2	8	9 + n	A, CY ← A + (HL + byte)	x	x	x
		A, [HL + B]	2	8	9 + n	A, CY ← A + (HL + B)	x	x	x
		A, [HL + C]	2	8	9 + n	A, CY ← A + (HL + C)	x	x	x
	ADDC	A, #byte	2	4	–	A, CY ← A + byte + CY	x	x	x
		saddr, #byte	3	6	8	(saddr), CY ← (saddr) + byte + CY	x	x	x
		A, r Note 4	2	4	–	A, CY ← A + r + CY	x	x	x
		r, A	2	4	–	r, CY ← r + A + CY	x	x	x
		A, saddr	2	4	5	A, CY ← A + (saddr) + CY	x	x	x
		A, !addr16	3	8	9 + n	A, CY ← A + (addr16) + CY	x	x	x
		A, [HL]	1	4	5 + n	A, CY ← A + (HL) + CY	x	x	x
		A, [HL + byte]	2	8	9 + n	A, CY ← A + (HL + byte) + CY	x	x	x
		A, [HL + B]	2	8	9 + n	A, CY ← A + (HL + B) + CY	x	x	x
A, [HL + C]	2	8	9 + n	A, CY ← A + (HL + C) + CY	x	x	x		

- Notes**
1. When the internal high-speed RAM area is accessed or instruction with no data access.
 2. When an area except the internal high-speed RAM area is accessed.
 3. Only when rp = BC, DE or HL
 4. Except "r = A"

- Remarks**
1. One instruction clock cycle is one cycle of the CPU clock (f_{CPU}) selected by the processor clock control register (PCC).
 2. This clock cycle applies to internal ROM program.
 3. n is the number of waits when external memory expansion area is read from.
 4. m is the number of waits when external memory expansion area is written to.

Instruction Group	Mnemonic	Operands	Byte	Clock		Operation	Flag		
				Note 1	Note 2		Z	AC	CY
8-bit operation	SUB	A, #byte	2	4	–	A, CY ← A – byte	×	×	×
		saddr, #byte	3	6	8	(saddr), CY ← (saddr) – byte	×	×	×
		A, r Note 3	2	4	–	A, CY ← A – r	×	×	×
		r, A	2	4	–	r, CY ← r – A	×	×	×
		A, saddr	2	4	5	A, CY ← A – (saddr)	×	×	×
		A, !addr16	3	8	9 + n	A, CY ← A – (addr16)	×	×	×
		A, [HL]	1	4	5 + n	A, CY ← A – (HL)	×	×	×
		A, [HL + byte]	2	8	9 + n	A, CY ← A – (HL + byte)	×	×	×
		A, [HL + B]	2	8	9 + n	A, CY ← A – (HL + B)	×	×	×
		A, [HL + C]	2	8	9 + n	A, CY ← A – (HL + C)	×	×	×
	SUBC	A, #byte	2	4	–	A, CY ← A – byte – CY	×	×	×
		saddr, #byte	3	6	8	(saddr), CY ← (saddr) – byte – CY	×	×	×
		A, r Note 3	2	4	–	A, CY ← A – r – CY	×	×	×
		r, A	2	4	–	r, CY ← r – A – CY	×	×	×
		A, saddr	2	4	5	A, CY ← A – (saddr) – CY	×	×	×
		A, !addr16	3	8	9 + n	A, CY ← A – (addr16) – CY	×	×	×
		A, [HL]	1	4	5 + n	A, CY ← A – (HL) – CY	×	×	×
		A, [HL + byte]	2	8	9 + n	A, CY ← A – (HL + byte) – CY	×	×	×
		A, [HL + B]	2	8	9 + n	A, CY ← A – (HL + B) – CY	×	×	×
		A, [HL + C]	2	8	9 + n	A, CY ← A – (HL + C) – CY	×	×	×
	AND	A, #byte	2	4	–	A ← A ∧ byte	×		
		saddr, #byte	3	6	8	(saddr) ← (saddr) ∧ byte	×		
		A, r Note 3	2	4	–	A ← A ∧ r	×		
		r, A	2	4	–	r ← r ∧ A	×		
		A, saddr	2	4	5	A ← A ∧ (saddr)	×		
		A, !addr16	3	8	9 + n	A ← A ∧ (addr16)	×		
		A, [HL]	1	4	5 + n	A ← A ∧ (HL)	×		
		A, [HL + byte]	2	8	9 + n	A ← A ∧ (HL + byte)	×		
		A, [HL + B]	2	8	9 + n	A ← A ∧ (HL + B)	×		
		A, [HL + C]	2	8	9 + n	A ← A ∧ (HL + C)	×		

- Notes**
1. When the internal high-speed RAM area is accessed or instruction with no data access.
 2. When an area except the internal high-speed RAM area is accessed.
 3. Except "r = A"

- Remarks**
1. One instruction clock cycle is one cycle of the CPU clock (f_{CPU}) selected by the processor clock control register (PCC).
 2. This clock cycle applies to internal ROM program.
 3. n is the number of waits when external memory expansion area is read from.

Instruction Group	Mnemonic	Operands	Byte	Clock		Operation	Flag			
				Note 1	Note 2		Z	AC	CY	
8-bit operation	OR	A, #byte	2	4	–	$A \leftarrow A \vee \text{byte}$		x		
		saddr, #byte	3	6	8	$(\text{saddr}) \leftarrow (\text{saddr}) \vee \text{byte}$		x		
		A, r	Note 3	2	4	–	$A \leftarrow A \vee r$		x	
		r, A		2	4	–	$r \leftarrow r \vee A$		x	
		A, saddr		2	4	5	$A \leftarrow A \vee (\text{saddr})$		x	
		A, !addr16		3	8	9 + n	$A \leftarrow A \vee (\text{addr16})$		x	
		A, [HL]		1	4	5 + n	$A \leftarrow A \vee (\text{HL})$		x	
		A, [HL + byte]		2	8	9 + n	$A \leftarrow A \vee (\text{HL} + \text{byte})$		x	
		A, [HL + B]		2	8	9 + n	$A \leftarrow A \vee (\text{HL} + B)$		x	
		A, [HL + C]		2	8	9 + n	$A \leftarrow A \vee (\text{HL} + C)$		x	
	XOR	A, #byte		2	4	–	$A \leftarrow A \nabla \text{byte}$		x	
		saddr, #byte		3	6	8	$(\text{saddr}) \leftarrow (\text{saddr}) \nabla \text{byte}$		x	
		A, r	Note 3	2	4	–	$A \leftarrow A \nabla r$		x	
		r, A		2	4	–	$r \leftarrow r \nabla A$		x	
		A, saddr		2	4	5	$A \leftarrow A \nabla (\text{saddr})$		x	
		A, !addr16		3	8	9 + n	$A \leftarrow A \nabla (\text{addr16})$		x	
		A, [HL]		1	4	5 + n	$A \leftarrow A \nabla (\text{HL})$		x	
		A, [HL + byte]		2	8	9 + n	$A \leftarrow A \nabla (\text{HL} + \text{byte})$		x	
		A, [HL + B]		2	8	9 + n	$A \leftarrow A \nabla (\text{HL} + B)$		x	
		A, [HL + C]		2	8	9 + n	$A \leftarrow A \nabla (\text{HL} + C)$		x	
	CMP	A, #byte		2	4	–	$A - \text{byte}$	x	x	x
		saddr, #byte		3	6	8	$(\text{saddr}) - \text{byte}$	x	x	x
		A, r	Note 3	2	4	–	$A - r$	x	x	x
		r, A		2	4	–	$r - A$	x	x	x
		A, saddr		2	4	5	$A - (\text{saddr})$	x	x	x
		A, !addr16		3	8	9 + n	$A - (\text{addr16})$	x	x	x
		A, [HL]		1	4	5 + n	$A - (\text{HL})$	x	x	x
A, [HL + byte]			2	8	9 + n	$A - (\text{HL} + \text{byte})$	x	x	x	
A, [HL + B]			2	8	9 + n	$A - (\text{HL} + B)$	x	x	x	
A, [HL + C]		2	8	9 + n	$A - (\text{HL} + C)$	x	x	x		

- Notes**
1. When the internal high-speed RAM area is accessed or instruction with no data access.
 2. When an area except the internal high-speed RAM area is accessed.
 3. Except "r = A"

- Remarks**
1. One instruction clock cycle is one cycle of the CPU clock (f_{CPU}) selected by the processor clock control register (PCC).
 2. This clock cycle applies to internal ROM program.
 3. n is the number of waits when external memory expansion area is read from.

Instruction Group	Mnemonic	Operands	Byte	Clock		Operation	Flag		
				Note 1	Note 2		Z	AC	CY
16-bit operation	ADDW	AX, #word	3	6	–	AX, CY ← AX + word	×	×	×
	SUBW	AX, #word	3	6	–	AX, CY ← AX – word	×	×	×
	CMPW	AX, #word	3	6	–	AX – word	×	×	×
Multiply/divide	MULU	X	2	16	–	AX ← A × X			
	DIVUW	C	2	25	–	AX (Quotient), C (Remainder) ← AX ÷ C			
Increment/decrement	INC	r	1	2	–	r ← r + 1	×	×	
		saddr	2	4	6	(saddr) ← (saddr) + 1	×	×	
	DEC	r	1	2	–	r ← r – 1	×	×	
		saddr	2	4	6	(saddr) ← (saddr) – 1	×	×	
	INCW	rp	1	4	–	rp ← rp + 1			
DECW	rp	1	4	–	rp ← rp – 1				
Rotate	ROR	A, 1	1	2	–	(CY, A ₇ ← A ₀ , A _{m-1} ← A _m) × 1 time			×
	ROL	A, 1	1	2	–	(CY, A ₀ ← A ₇ , A _{m+1} ← A _m) × 1 time			×
	RORC	A, 1	1	2	–	(CY ← A ₀ , A ₇ ← CY, A _{m-1} ← A _m) × 1 time			×
	ROLC	A, 1	1	2	–	(CY ← A ₇ , A ₀ ← CY, A _{m+1} ← A _m) × 1 time			×
	ROR4	[HL]	2	10	12 + n + m	A ₃₋₀ ← (HL) ₃₋₀ , (HL) ₇₋₄ ← A ₃₋₀ , (HL) ₃₋₀ ← (HL) ₇₋₄			
	ROL4	[HL]	2	10	12 + n + m	A ₃₋₀ ← (HL) ₇₋₄ , (HL) ₃₋₀ ← A ₃₋₀ , (HL) ₇₋₄ ← (HL) ₃₋₀			
BCD adjust	ADJBA		2	4	–	Decimal Adjust Accumulator after Addition	×	×	×
	ADJBS		2	4	–	Decimal Adjust Accumulator after Subtract	×	×	×
Bit manipulate	MOV1	CY, saddr.bit	3	6	7	CY ← (saddr.bit)			×
		CY, sfr.bit	3	–	7	CY ← sfr.bit			×
		CY, A.bit	2	4	–	CY ← A.bit			×
		CY, PSW.bit	3	–	7	CY ← PSW.bit			×
		CY, [HL].bit	2	6	7 + n	CY ← (HL).bit			×
		saddr.bit, CY	3	6	8	(saddr.bit) ← CY			
		sfr.bit, CY	3	–	8	sfr.bit ← CY			
		A.bit, CY	2	4	–	A.bit ← CY			
		PSW.bit, CY	3	–	8	PSW.bit ← CY			×
		[HL].bit, CY	2	6	8 + n + m	(HL).bit ← CY			

- Notes**
1. When the internal high-speed RAM area is accessed or instruction with no data access.
 2. When an area except the internal high-speed RAM area is accessed.

- Remarks**
1. One instruction clock cycle is one cycle of the CPU clock (f_{CPU}) selected by the processor clock control register (PCC).
 2. This clock cycle applies to internal ROM program.
 3. n is the number of waits when external memory expansion area is read from.
 4. m is the number of waits when external memory expansion area is written to.

Instruction Group	Mnemonic	Operands	Byte	Clock		Operation	Flag			
				Note 1	Note 2		Z	AC	CY	
Bit manipulate	AND1	CY, saddr.bit	3	6	7	$CY \leftarrow CY \wedge (\text{saddr.bit})$			×	
		CY, sfr.bit	3	–	7	$CY \leftarrow CY \wedge \text{sfr.bit}$			×	
		CY, A.bit	2	4	–	$CY \leftarrow CY \wedge A.\text{bit}$			×	
		CY, PSW.bit	3	–	7	$CY \leftarrow CY \wedge \text{PSW.bit}$			×	
		CY, [HL].bit	2	6	7 + n	$CY \leftarrow CY \wedge (\text{HL}).\text{bit}$			×	
	OR1	CY, saddr.bit	3	6	7	$CY \leftarrow CY \vee (\text{saddr.bit})$			×	
		CY, sfr.bit	3	–	7	$CY \leftarrow CY \vee \text{sfr.bit}$			×	
		CY, A.bit	2	4	–	$CY \leftarrow CY \vee A.\text{bit}$			×	
		CY, PSW.bit	3	–	7	$CY \leftarrow CY \vee \text{PSW.bit}$			×	
		CY, [HL].bit	2	6	7 + n	$CY \leftarrow CY \vee (\text{HL}).\text{bit}$			×	
	XOR1	CY, saddr.bit	3	6	7	$CY \leftarrow CY \nabla (\text{saddr.bit})$			×	
		CY, sfr.bit	3	–	7	$CY \leftarrow CY \nabla \text{sfr.bit}$			×	
		CY, A.bit	2	4	–	$CY \leftarrow CY \nabla A.\text{bit}$			×	
		CY, PSW.bit	3	–	7	$CY \leftarrow CY \nabla \text{PSW.bit}$			×	
		CY, [HL].bit	2	6	7 + n	$CY \leftarrow CY \nabla (\text{HL}).\text{bit}$			×	
	SET1	saddr.bit	2	4	6	$(\text{saddr.bit}) \leftarrow 1$				
		sfr.bit	3	–	8	$\text{sfr.bit} \leftarrow 1$				
		A.bit	2	4	–	$A.\text{bit} \leftarrow 1$				
		PSW.bit	2	–	6	$\text{PSW.bit} \leftarrow 1$		×	×	×
		[HL].bit	2	6	8 + n + m	$(\text{HL}).\text{bit} \leftarrow 1$				
	CLR1	saddr.bit	2	4	6	$(\text{saddr.bit}) \leftarrow 0$				
		sfr.bit	3	–	8	$\text{sfr.bit} \leftarrow 0$				
		A.bit	2	4	–	$A.\text{bit} \leftarrow 0$				
		PSW.bit	2	–	6	$\text{PSW.bit} \leftarrow 0$		×	×	×
		[HL].bit	2	6	8 + n + m	$(\text{HL}).\text{bit} \leftarrow 0$				
	SET1	CY	1	2	–	$CY \leftarrow 1$			1	
	CLR1	CY	1	2	–	$CY \leftarrow 0$			0	
	NOT1	CY	1	2	–	$CY \leftarrow \overline{CY}$			×	

- Notes**
1. When the internal high-speed RAM area is accessed or instruction with no data access.
 2. When an area except the internal high-speed RAM area is accessed.

- Remarks**
1. One instruction clock cycle is one cycle of the CPU clock (f_{CPU}) selected by the processor clock control register (PCC).
 2. This clock cycle applies to internal ROM program.
 3. n is the number of waits when external memory expansion area is read from.
 4. m is the number of waits when external memory expansion area is written to.

Instruction Group	Mnemonic	Operands	Byte	Clock		Operation	Flag		
				Note 1	Note 2		Z	AC	CY
Call/return	CALL	!addr16	3	7	–	$(SP - 1) \leftarrow (PC + 3)_H, (SP - 2) \leftarrow (PC + 3)_L,$ $PC \leftarrow \text{addr16}, SP \leftarrow SP - 2$			
	CALLF	!addr11	2	5	–	$(SP - 1) \leftarrow (PC + 2)_H, (SP - 2) \leftarrow (PC + 2)_L,$ $PC_{15-11} \leftarrow 00001, PC_{10-0} \leftarrow \text{addr11},$ $SP \leftarrow SP - 2$			
	CALLT	[addr5]	1	6	–	$(SP - 1) \leftarrow (PC + 1)_H, (SP - 2) \leftarrow (PC + 1)_L,$ $PC_H \leftarrow (00000000, \text{addr5} + 1),$ $PC_L \leftarrow (00000000, \text{addr5}),$ $SP \leftarrow SP - 2$			
	BRK		1	6	–	$(SP - 1) \leftarrow PSW, (SP - 2) \leftarrow (PC + 1)_H,$ $(SP - 3) \leftarrow (PC + 1)_L, PC_H \leftarrow (003FH),$ $PC_L \leftarrow (003EH), SP \leftarrow SP - 3, IE \leftarrow 0$			
	RET		1	6	–	$PC_H \leftarrow (SP + 1), PC_L \leftarrow (SP),$ $SP \leftarrow SP + 2$			
	RETI		1	6	–	$PC_H \leftarrow (SP + 1), PC_L \leftarrow (SP),$ $PSW \leftarrow (SP + 2), SP \leftarrow SP + 3,$ $NMIS \leftarrow 0$	R	R	R
	RETB		1	6	–	$PC_H \leftarrow (SP + 1), PC_L \leftarrow (SP),$ $PSW \leftarrow (SP + 2), SP \leftarrow SP + 3$	R	R	R
Stack manipulate	PUSH	PSW	1	2	–	$(SP - 1) \leftarrow PSW, SP \leftarrow SP - 1$			
		rp	1	4	–	$(SP - 1) \leftarrow rp_H, (SP - 2) \leftarrow rp_L,$ $SP \leftarrow SP - 2$			
	POP	PSW	1	2	–	$PSW \leftarrow (SP), SP \leftarrow SP + 1$	R	R	R
		rp	1	4	–	$rp_H \leftarrow (SP + 1), rp_L \leftarrow (SP),$ $SP \leftarrow SP + 2$			
	MOVW	SP, #word	4	–	10	$SP \leftarrow \text{word}$			
		SP, AX	2	–	8	$SP \leftarrow AX$			
AX, SP		2	–	8	$AX \leftarrow SP$				
Unconditional branch	BR	!addr16	3	6	–	$PC \leftarrow \text{addr16}$			
		\$addr16	2	6	–	$PC \leftarrow PC + 2 + \text{jdisp8}$			
		AX	2	8	–	$PC_H \leftarrow A, PC_L \leftarrow X$			
Conditional branch	BC	\$addr16	2	6	–	$PC \leftarrow PC + 2 + \text{jdisp8}$ if CY = 1			
	BNC	\$addr16	2	6	–	$PC \leftarrow PC + 2 + \text{jdisp8}$ if CY = 0			
	BZ	\$addr16	2	6	–	$PC \leftarrow PC + 2 + \text{jdisp8}$ if Z = 1			
	BNZ	\$addr16	2	6	–	$PC \leftarrow PC + 2 + \text{jdisp8}$ if Z = 0			

- Notes**
1. When the internal high-speed RAM area is accessed or instruction with no data access.
 2. When an area except the internal high-speed RAM area is accessed.

- Remarks**
1. One instruction clock cycle is one cycle of the CPU clock (f_{CPU}) selected by the processor clock control register (PCC).
 2. This clock cycle applies to internal ROM program.

Instruction Group	Mnemonic	Operands	Byte	Clock		Operation	Flag		
				Note 1	Note 2		Z	AC	CY
Conditional branch	BT	saddr.bit, \$addr16	3	8	9	PC ← PC + 3 + jdisp8 if(saddr.bit) = 1			
		sfr.bit, \$addr16	4	–	11	PC ← PC + 4 + jdisp8 if sfr.bit = 1			
		A.bit, \$addr16	3	8	–	PC ← PC + 3 + jdisp8 if A.bit = 1			
		PSW.bit, \$addr16	3	–	9	PC ← PC + 3 + jdisp8 if PSW.bit = 1			
		[HL].bit, \$addr16	3	10	11 + n	PC ← PC + 3 + jdisp8 if (HL).bit = 1			
	BF	saddr.bit, \$addr16	4	10	11	PC ← PC + 4 + jdisp8 if(saddr.bit) = 0			
		sfr.bit, \$addr16	4	–	11	PC ← PC + 4 + jdisp8 if sfr.bit = 0			
		A.bit, \$addr16	3	8	–	PC ← PC + 3 + jdisp8 if A.bit = 0			
		PSW.bit, \$addr16	4	–	11	PC ← PC + 4 + jdisp8 if PSW. bit = 0			
		[HL].bit, \$addr16	3	10	11 + n	PC ← PC + 3 + jdisp8 if (HL).bit = 0			
	BTCLR	saddr.bit, \$addr16	4	10	12	PC ← PC + 4 + jdisp8 if(saddr.bit) = 1 then reset(saddr.bit)			
		sfr.bit, \$addr16	4	–	12	PC ← PC + 4 + jdisp8 if sfr.bit = 1 then reset sfr.bit			
		A.bit, \$addr16	3	8	–	PC ← PC + 3 + jdisp8 if A.bit = 1 then reset A.bit			
		PSW.bit, \$addr16	4	–	12	PC ← PC + 4 + jdisp8 if PSW.bit = 1 then reset PSW.bit	×	×	×
		[HL].bit, \$addr16	3	10	12 + n + m	PC ← PC + 3 + jdisp8 if (HL).bit = 1 then reset (HL).bit			
DBNZ	B, \$addr16	2	6	–	B ← B – 1, then PC ← PC + 2 + jdisp8 if B ≠ 0				
	C, \$addr16	2	6	–	C ← C – 1, then PC ← PC + 2 + jdisp8 if C ≠ 0				
	saddr. \$addr16	3	8	10	(saddr) ← (saddr) – 1, then PC ← PC + 3 + jdisp8 if(saddr) ≠ 0				
CPU control	SEL	RBn	2	4	–	RBS1, 0 ← n			
	NOP		1	2	–	No Operation			
	EI		2	–	6	IE ← 1(Enable Interrupt)			
	DI		2	–	6	IE ← 0(Disable Interrupt)			
	HALT		2	6	–	Set HALT Mode			
	STOP		2	6	–	Set STOP Mode			

- Notes**
1. When the internal high-speed RAM area is accessed or instruction with no data access.
 2. When an area except the internal high-speed RAM area is accessed.

- Remarks**
1. One instruction clock cycle is one cycle of the CPU clock (f_{CPU}) selected by the processor clock control register (PCC).
 2. This clock cycle applies to internal ROM program.
 3. n is the number of waits when external memory expansion area is read from.
 4. m is the number of waits when external memory expansion area is written to.

27.3 Instructions Listed by Addressing Type

(1) 8-bit instructions

MOV, XCH, ADD, ADDC, SUB, SUBC, AND, OR, XOR, CMP, MULU, DIVUW, INC, DEC, ROR, ROL, RORC, ROLC, ROR4, ROL4, PUSH, POP, DBNZ

Second Operand First Operand	#byte	A	r Note	sfr	saddr	laddr16	PSW	[DE]	[HL]	[HL + byte] [HL + B] [HL + C]	\$addr16	1	None
A	ADD ADDC SUB SUBC AND OR XOR CMP		MOV XCH ADD ADDC SUB SUBC AND OR XOR CMP	MOV XCH	MOV XCH ADD ADDC SUB SUBC AND OR XOR CMP	MOV XCH ADD ADDC SUB SUBC AND OR XOR CMP	MOV	MOV XCH	MOV XCH ADD ADDC SUB SUBC AND OR XOR CMP	MOV XCH ADD ADDC SUB SUBC AND OR XOR CMP		ROR ROL RORC ROLC	
r	MOV	MOV ADD ADDC SUB SUBC AND OR XOR CMP											INC DEC
B, C											DBNZ		
sfr	MOV	MOV											
saddr	MOV ADD ADDC SUB SUBC AND OR XOR CMP	MOV									DBNZ		INC DEC
laddr16		MOV											
PSW	MOV	MOV											PUSH POP
[DE]		MOV											
[HL]		MOV											ROR4 ROL4
[HL + byte] [HL + B] [HL + C]		MOV											
X													MULU
C													DIVUW

Note Except r = A

(2) 16-bit instructions

MOVW, XCHW, ADDW, SUBW, CMPW, PUSH, POP, INCW, DECW

Second Operand 1st Operand	#word	AX	rp ^{Note}	sfrp	saddrp	!addr16	SP	None
AX	ADDW SUBW CMPW		MOVW XCHW	MOVW	MOVW	MOVW	MOVW	
rp	MOVW	MOVW ^{Note}						INCW DECW PUSH POP
sfrp	MOVW	MOVW						
saddrp	MOVW	MOVW						
!addr16		MOVW						
SP	MOVW	MOVW						

Note Only when rp = BC, DE, HL

(3) Bit manipulation instructions

MOV1, AND1, OR1, XOR1, SET1, CLR1, NOT1, BT, BF, BTCLR

Second Operand First Operand	A.bit	sfr.bit	saddr.bit	PSW.bit	[HL].bit	CY	\$addr16	None
A.bit						MOV1	BT BF BTCLR	SET1 CLR1
sfr.bit						MOV1	BT BF BTCLR	SET1 CLR1
saddr.bit						MOV1	BT BF BTCLR	SET1 CLR1
PSW.bit						MOV1	BT BF BTCLR	SET1 CLR1
[HL].bit						MOV1	BT BF BTCLR	SET1 CLR1
CY	MOV1 AND1 OR1 XOR1	MOV1 AND1 OR1 XOR1	MOV1 AND1 OR1 XOR1	MOV1 AND1 OR1 XOR1	MOV1 AND1 OR1 XOR1			SET1 CLR1 NOT1

(4) Call/instructions/branch instructions

CALL, CALLF, CALLT, BR, BC, BNC, BZ, BNZ, BT, BF, BTCLR, DBNZ

Second Operand First Operand	AX	!addr16	!addr11	[addr5]	\$addr16
Basic instruction	BR	CALL BR	CALLF	CALLT	BR BC BNC BZ BNZ
Compound instruction					BT BF BTCLR DBNZ

(5) Other instructions

ADJBA, ADJBS, BRK, RET, RETI, RETB, SEL, NOP, EI, DI, HALT, STOP

[MEMO]

★

**APPENDIX A DIFFERENCES BETWEEN μ PD78054, 78054Y SUBSERIES
AND μ PD78058F, 78058FY SUBSERIES**

Table A-1 shows the major differences between the μ PD78054, 78054Y Subseries and μ PD78058F, 78058FY Subseries.

Table A-1. Major differences between μ PD78054, 78054Y Subseries and μ PD78058F, 78058FY Subseries

Item \ Part Number	μ PD78054, 78054Y Subseries	μ PD78058F, 78058FY Subseries
EMI noise measure	None	Provided
PROM version	μ PD78P054 μ PD78P058 μ PD78P058Y	μ PD78P058F μ PD78P058Y
Supply voltage	$V_{DD} = 2.0$ to 6.0 V	$V_{DD} = 2.7$ to 6.0 V
Internal ROM capacity	μ PD78052 : 16 Kbytes μ PD78053 : 24 Kbytes μ PD78054 : 32 Kbytes μ PD78P054 : 32 Kbytes μ PD78055 : 40 Kbytes μ PD78056 : 48 Kbytes μ PD78058 : 60 Kbytes μ PD78P058 : 60 Kbytes	μ PD78056F : 48 Kbytes μ PD78058F : 60 Kbytes
Internal high-speed RAM capacity	μ PD78052 : 512 bytes μ PD78053 : 1024 bytes μ PD78054 : 1024 bytes μ PD78P054 : 1024 bytes μ PD78055 : 1024 bytes μ PD78056 : 1024 bytes μ PD78058 : 1024 bytes μ PD78P058 : 1024 bytes	μ PD78056F : 1024 bytes μ PD78058F : 1024 bytes
Internal expansion RAM capacity	μ PD78058 : 1024 bytes μ PD78P058 : 1024 bytes	μ PD78058F : 1024 bytes
V_{DD} pin	Positive power supply (including ports)	Positive power supply (excluding ports)
V_{SS} pin	Ground potential (including ports)	Ground potential (excluding ports)
AV_{DD} pin	Analog power supply for A/D converter, D/A converter	Analog power supply for A/D converter, D/A converter and power supply for ports
AV_{SS} pin	Ground for A/D converter, D/A converter	Ground for A/D converter, D/A converter and ground for ports
Package	80-pin plastic QFP (14×14 mm, Resin thickness: 2.7 mm) 80-pin plastic QFP (14×14 mm, Resin thickness: 1.4 mm) 80-pin plastic TQFP (Fine pitch) (12×12 mm) 80-pin ceramic WQFN (14×14 mm) ^{Note}	80-pin plastic QFP (14×14 mm, Resin thickness: 2.7 mm) 80-pin plastic QFP (14×14 mm, Resin thickness: 1.4 mm) 80-pin plastic TQFP (Fine pitch) (12×12 mm)
Electrical characteristics, recommended soldering conditions	Refer to individual data sheet.	

Note PROM version only

APPENDIX B DEVELOPMENT TOOLS

The following development tools are available for the development of systems which employ the μ PD78054 and 78054Y subseries.

Figure B-1 shows the configuration of the development tools.

Figure B-1. Development Tool Configuration (1/2)

(1) When using in-circuit emulator IE-78K0-NS

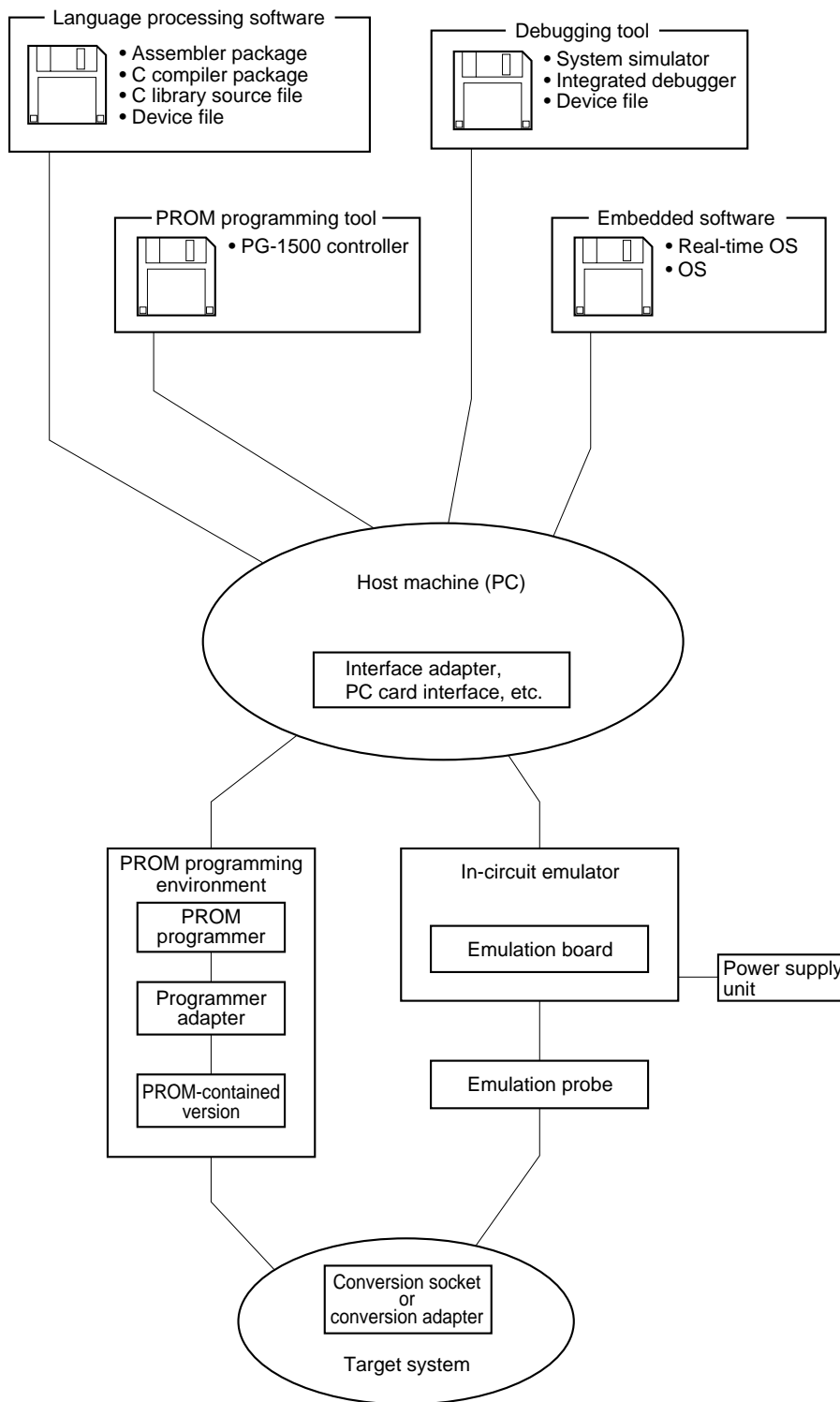
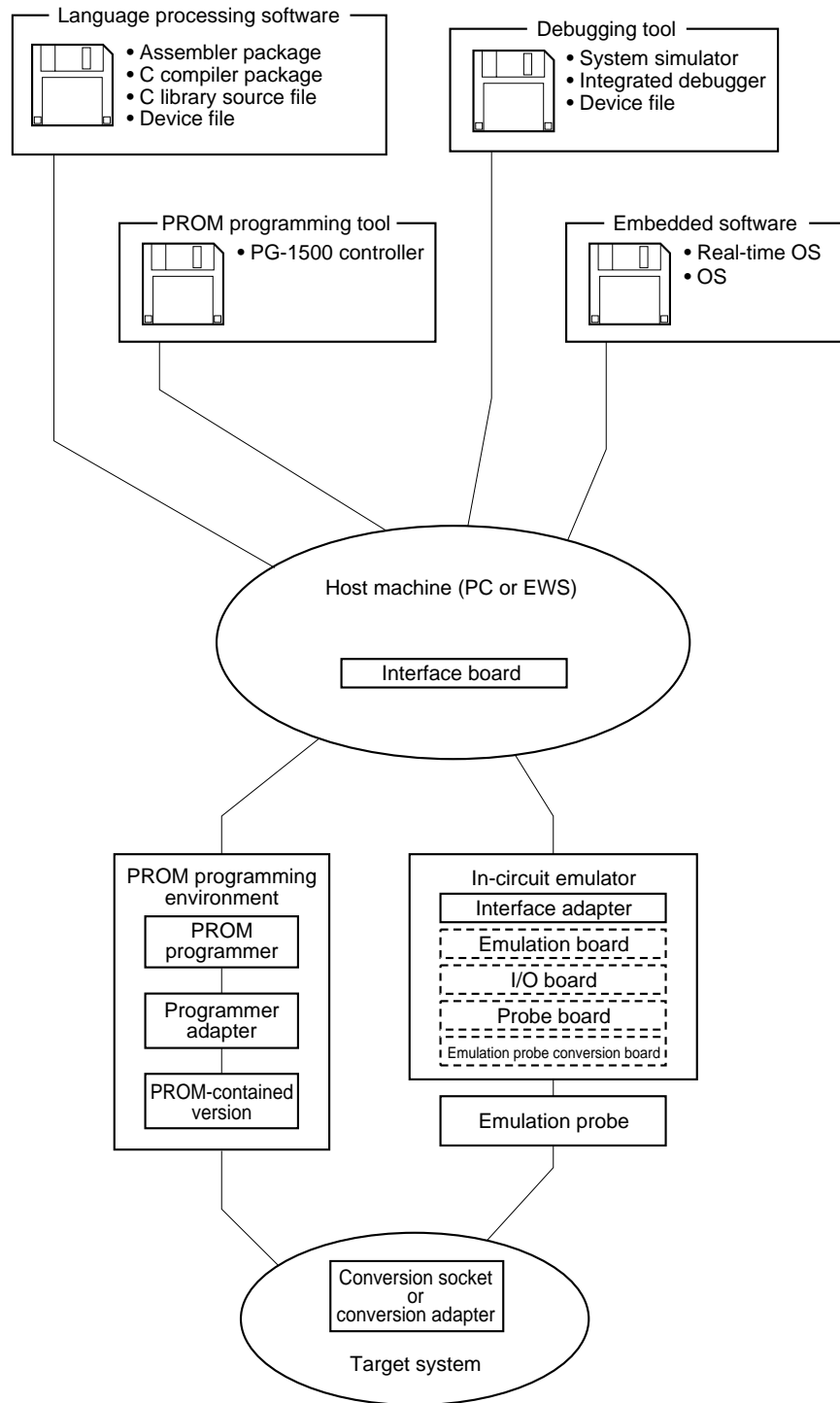


Figure B-1. Development Tool Configuration (2/2)

(2) When using in-circuit emulator IE-78001-R-A



Remark The parts shown within broken lines differ depending on the developing environment. Refer to **B.3.1 Hardware**.

B.1 Language Processing Software

RA78K/0 Assembler Package	<p>A program that converts a program written in mnemonic into object codes that microcomputers can process.</p> <p>Provided with functions to automatically perform generation of symbol table, optimizing processing of branch instructions, etc.</p> <p>Used in combination with separately available Device File (DF78054).</p> <p><Precautions for the use in PC environment> Although Assembler Package is a DOS-based application, it can be used in a Windows environment through the use of Project Manager (included in Assembler Package) on Windows.</p>
CC78K/0 C Compiler Package	<p>A program which converts a program written in C language into object codes that microcomputers can process.</p> <p>Used in combination with separately available Assembler Package and Device File.</p> <p><Precautions for the use in PC environment> Although C Compiler Package is a DOS-based application, it can be used in Windows environment through the use of Project Manager (included in Assembler Package) on Windows.</p>
DF78054 ^{Note} Device File	<p>A file which contains information peculiar to the device.</p> <p>Used in combination with separately available tools (RA78K/0, CC78K/0, SM78K0, ID78K0-NS, ID78K0).</p> <p>Supporting OS and host machines are dependent on the tool to be combined with.</p>
CC78K/0-L C Library Source File	<p>A source file of functions which configure the object library included in C Compiler package.</p> <p>Required when modifying the object library included in C Compiler Package for customization.</p> <p>Since this is a source file, its operation environment is independent from OS.</p>
	Part number: μ SxxxxRA78K0
	Part number: μ SxxxxCC78K0
	Part number: μ SxxxxDF78054
	Part number: μ SxxxxCC78K0-L

Note The DF78054 can commonly be used for all the products of the RA78K/0, CC78K/0, SM78K0, ID78K0-NS, and ID78K0.

Remark xxxx in the part number differs depending on the host machine and OS used.

μSxxxx RA78K0
 μSxxxx CC78K0
 μSxxxx DF78078
 μSxxxx CC78K0-L

xxxx	Host Machine	OS	Supply Media
AA13	PC-9800 series	Japanese Windows ^{Notes 1, 2}	3.5-inch 2HD FD
AB13	IBM PC/AT™ and compatibles	Japanese Windows ^{Notes 1, 2}	3.5-inch 2HC FD
BB13		English Windows ^{Notes 1, 2}	
3P16	HP9000 series 700™	HP-UXTM (rel. 9.05)	DAT (DDS)
3K13	SPARCstation™	SunOSTM (rel. 4.1.4)	3.5-inch 2HC FD
3K15			1/4-inch CGMT
3R13	NEWS™ (RISC)	NEWS-OSTM (rel. 6.1)	3.5-inch 2HC FD

- Notes**
1. Operates also in DOS environment.
 2. Does not support WindowsNT™

B.2 PROM Writing Tools

B.2.1 Hardware

PG-1500 PROM Programmer	A PROM programmer that, by connecting the attached board and separately available PROM programmer adapter, is capable of programming single-chip microcomputers incorporating a PROM on stand-alone basis or through operation from the host machine. Also capable of programming typical 256-Kbit to 4-Mbit PROM.
PA-78P054GC PA-78P054GK PA-78P054KK-T PROM Programmer Adapter	A PROM programmer adapter for the μ PD78P054, 78P058, and 78P058Y. Used connected to the PG-1500. PA-78P054GC : 80-pin plastic QFP (GC-3B9, GC-8BT type) PA-78P054GK : 80-pin plastic QFP (GK-BE9 type) PA-78P054KK-T : 80-pin ceramic WQFN (KK-T type)

B.2.2 Software

PG-1500 Controller	Connects PG-1500 and the host machine with serial and parallel interface, and controls the PG-1500 on the host machine. The PG-1500 controller is a DOS-based application. Use it with the DOS prompt on Windows.
	Part number: μ SxxxxPG1500

Remark xxxx in the part number differs depending on the host machine and OS used.

μ Sxxxx PG1500

xxxx	Host Machine	OS	Supply Media
5A13	PC-9800 series	MS-DOS (ver. 3.30 to ver. 6.2 ^{Note})	3.5-inch 2HD FD
5B13	IBM PC/AT and compatibles	Refer to B.4	3.5-inch 2HC FD

Note MS-DOS ver. 5.0 or later has a task swap function, but it cannot be used with the above software.

B.3 Debugging Tools

B.3.1 Hardware (1/2)

(1) When using in-circuit emulator IE-78K0-NS

IE-78K0-NS ^{Note} In-circuit Emulator	An in-circuit emulator to debug hardware and software when developing application systems that use the 78K/0 Series. Supports integrated debugger (ID78K0-NS). Used in combination with a power supply unit, emulation probe, and interface adapter to connect to the host machine.
IE-70000-MC-PS-B Power Supply Adapter	An adapter to supply voltage from AC100 to 240-V outlet.
IE-70000-98-IF-C ^{Note} Interface Adapter	An adapter required for using a PC-9800 series computer (except notebook-type personal computer) as the host machine for the IE-78K0-NS.
IE-70000-CD-IF ^{Note} PC Card Interface	A PC card and an interface cable required for using PC-9800 series notebook-type personal computer as the host machine for the IE-78K0-NS.
IE-70000-PC-IF-C ^{Note} Interface Adapter	An adapter required when using an IBM PC/AT and compatible as the host machine for the IE-78K0-NS.
IE-780308-NS-EM1 ^{Note} Emulation Board	A board to emulate peripheral hardware peculiar to the device. Used in combination with an in-circuit emulator.
NP-80GC Emulation Probe	A probe to connect an in-circuit emulator and a target system. For 80-pin plastic QFP (GC-3B9, GC-8BT type)
EV-9200GC-80 Conversion Socket (refer to Figure B-2)	A conversion socket to connect the board of a target system that is designed to mount 80-pin plastic QFP (GC-3B9, GC-8BT type) and the NP-80GC. The μ PD78P054KK-T, 78P058KK-T, and 78P058YKK-T (ceramic WQFN) can be mounted instead of connecting NP-80GC.
NP-80GK Emulation Probe	A probe to connect an in-circuit emulator and the target system. For 80-pin plastic TQFP (GK-BE9 type).
TGK-080SDW Conversion Adapter (refer to Figure B-3)	A conversion adapter to connect the board of a target system designed to mount 80-pin plastic QFP (GK-BE9 type) to the NP-80GK.

Note Under development

- Remarks**
1. The NP-80GC and NP-80GK are products of Naito Densai Machidaseisakusho Co., Ltd.
Contact: Naito Densai Machidaseisakusho Co., Ltd (Tel: (044)822-3813)
 2. The TGK-080SDW is a product of TOKYO ELETECH Corporation.
Contact: Daimaru Kogyo Co., Ltd.
Tokyo Electronic Component Department (Tel: (03)3820-7112)
Osaka Electronic Component Department (Tel: (06)244-6672)
 3. The TGK-080SDW is sold singly.
 4. The EV-9200GC-80 is sold in a set of five.

B.3.1 Hardware (2/2)

(2) When using in-circuit emulator IE-78001-R-A

IE-78001-R-A ^{Note 1} In-circuit Emulator	An in-circuit emulator to debug hardware and software when developing application systems that use the 78K/0 Series. Supports integrated debugger (ID78K0). Used in combination with an interface adapter to connect to an emulation probe and the host machine.
IE-70000-98-IF-B or IE-70000-98-IF-C ^{Note 1} Interface Adapter	An adapter required for using a PC-9800 series (except notebook-type personal computer) as the host machine for the IE-78001-R-A.
IE-70000-PC-IF-B or IE-70000-PC-IF-C ^{Note 1} Interface adapter	An adapter required for using an IBM PC/AT or compatible as the host machine for the IE-78001-R-A.
IE-78000-R-SV3 Interface Adapter	An adapter and a cable required for using EWS as the host machine for the IE-78001-R-A. Used connected to the board in the IE-78001-R-A. Supports 10Base-5 for Ethernet™. A separately available adapter required for other systems.
IE-780308-NS-EM1 ^{Note 1} Emulation Board	A board to emulate peripheral hardware peculiar to the device. Used in combination with an in-circuit emulator and emulation probe conversion board.
IE-78K0-R-EX1 ^{Note 1} Emulation Probe Conversion Board	A board required for using the IE-780308-NS-EM1 with the IE-78001-R-A
IE-780308-R-EM IE-78064-R-EM ^{Note 2} Emulation board	A board to emulate peripheral hardware peculiar to the device (IE-780308-R-EM supports 2.0 to 5.0V, IE-78064-R-EM supports 3.0 to 6.0V). Used in combination with the IE-78001-R-A.
EP-78230GC-R Emulation Probe	A probe to connect an in-circuit emulator and the target system. For 80-pin plastic QFP (GC-3B9, GC-8BT type).
EV-9200GC-80 Conversion Socket (refer to Figure B-2)	A conversion socket to connect the board of a target system designed to mount 80-pin plastic QFP (GC-3B9, GC-8BT type) and the EP-78230GC-R. The μ PD78P054KK-T, 78P058KK-T, or 78P058YKK-T (ceramic WQFN) can be mounted instead of connecting the EP-78230GC-R.
EP-78054GK-R Emulation Probe	A probe to connect an in-circuit emulator and the target system. For 80-pin plastic TQFP (GK-BE9 type).
TGK-080SDW Conversion Adapter (refer to Figure B-3)	A conversion adapter to connect the board of a target system designed to mount 80-pin plastic TQFP (GK-BE9 type) to the EP-78054GK-R.

- Notes**
1. Under development
 2. Maintenance product

- Remarks**
1. The TGK-080SDW is a product of TOKYO ELETECH Corporation.
Contact: Daimaru Kogyo Co., Ltd.
Tokyo Electronic Component Department (Tel: (03)3820-7112)
Osaka Electronic Component Department (Tel: (06)244-6672)
 2. The TGK-080SDW is sold singly.
 3. The EV-9200GC-80 is sold in a set of five.

B.3.2 Software (1/2)

SM78K0 System Simulator	Capable of debugging in C source level or assembler level while simulating the operation of the target system on the host machine. The SM78K0 operates on Windows. The use of the SM78K0 enables the verification of logic and performance of applications independently from hardware development without using in-circuit emulator and improves the development efficiency and the software quality. Used in combination with separately available Device File (DF78054). Part number: μ SxxxxSM78K0
----------------------------	--

Remark xxxx in the part number differs depending on the host machine and OS used.

μ Sxxxx SM78K0

xxxx	Host Machine	OS	Supply Media
AA13	PC-9800 series	Japanese Windows ^{Notes 1, 2}	3.5-inch 2HD FD
AB13	IBM PC/AT and	Japanese Windows ^{Notes 1, 2}	3.5-inch 2HC FD
BB13	compatible	English Windows ^{Note}	

Note Does not support WindowsNT.

B.3.2 Software (2/2)

ID78K0-NS ^{Note} Integrated debugger (supporting in-circuit emulator IE-78K0-NS)	A control program to debug the 78K/0 Series. Adopting Windows on personal computers and OSF/Motif™ on EWS as graphical user interface, presents the appearance and the operability conforming to them. Enhancing the debugging function that supports C language, the trace result can be displayed in the C language level by using window integration function which correlates the source program, disassembly display, and memory display to the trace result. In addition, the debugging efficiency of programs using real-time OS can be improved by integrating function extension modules such as task debuggers and system performance analyzers. Used in combination with separately available Device File (DF78054). Part number: μ SxxxxID78K0-NS, μ SxxxxID78K0.
ID78K0 Integrated Debugger (supporting in-circuit emulator IE-78001-R-A)	

Note Under development

Remark xxxx in the part number differs depending on the host machine and OS used.

μ Sxxxx ID78K0-NS

xxxx	Host Machine	OS	Supply Media
AA13	PC-9800 series	Japanese Windows ^{Note}	3.5-inch 2HD FD
AB13	IBM PC/AT and compatible	Japanese Windows ^{Note}	3.5-inch 2HC FD
BB13		English Windows ^{Note}	

Note Does not support WindowsNT.

μ Sxxxx ID78K0

xxxx	Host Machine	OS	Supply Media
AA13	PC-9800 series	Japanese Windows ^{Note}	3.5-inch 2HD FD
AB13	IBM PC/AT and compatible	Japanese Windows ^{Note}	3.5-inch 2HC FD
BB13		English Windows ^{Note}	
3P16	HP9000 series 700	HP-UX (Rel. 9.05)	DAT (DDS)
3K13	SPARCstation	SunOS (Rel. 4.1.4)	3.5-inch 2HC FD
3K15			1/4-inch CGMT
3R13	NEWS (RISC)	NEWS-OS (Rel. 6.1)	3.5-inch 2HC FD

Note Does not support WindowsNT.

B.4 OS for IBM PC

The following OSs are supported for IBM PC.

Table B-1. OS for IBM PC

OS	Version
PC DOS	Ver. 5.02 to Ver. 6.3
	J6.1/V ^{Note} to J6.3/V ^{Note}
IBM DOS™	J5.02/V ^{Note}
MS-DOS	Ver. 5.0 to Ver. 6.22
	5.0/V ^{Note} to 6.2/V ^{Note}

Note Only English mode is supported.

Caution MS-DOS ver. 5.0 or later has a task swap function, but it cannot be used with the above software.

B.5 Upgrading Former In-circuit Emulators for 78K/0 Series to IE-78001-R-A

If you have a former in-circuit emulator for the 78K/0 Series (IE-78000-R or IE-78000-R-A), your in-circuit emulator can be upgraded to be equivalent to the IE-78001-R-A in-circuit emulator by simply replacing the break board with the IE-78001-R-BK (under development).

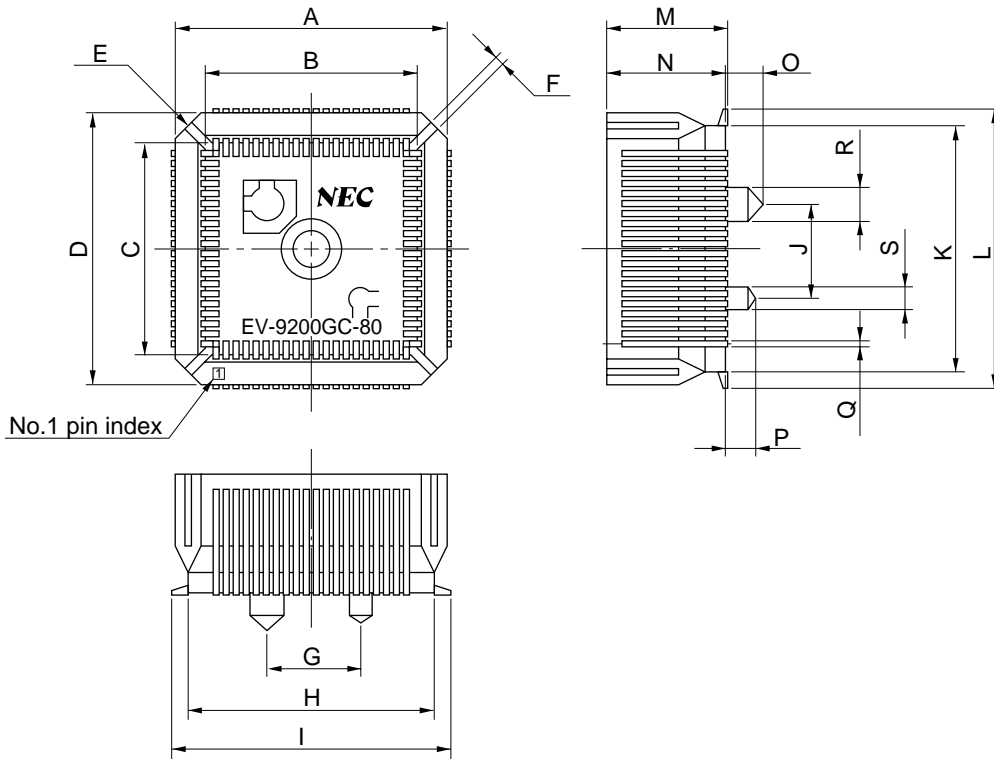
Table B-2. Upgrading Former In-circuit Emulators for 78K/0 Series to IE-78001-R-A

In-circuit Emulator	Cabinet Upgrading ^{Note}	Board to be Purchased
IE-78000-R	Required	IE-78001-R-BK
IE-78000-R-A	Not required	

Note To upgrade your cabinet, bring it to NEC.

Drawing and Footprint for Conversion Socket (EV-9200GC-80)

Figure B-2. EV-9200GC-80 Drawing (For Reference Only)

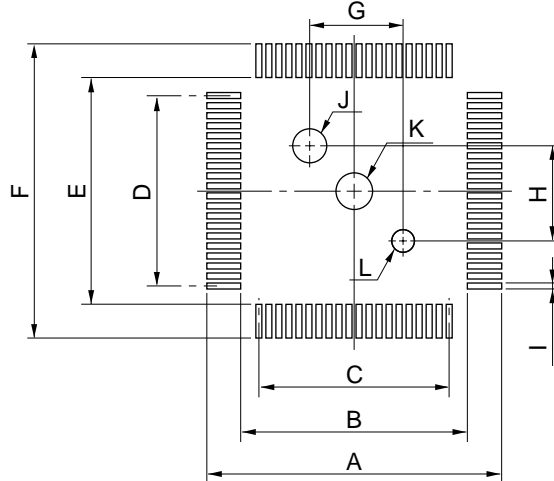


EV-9200GC-80-G0

ITEM	MILLIMETERS	INCHES
A	18.0	0.709
B	14.4	0.567
C	14.4	0.567
D	18.0	0.709
E	4-C 2.0	4-C 0.079
F	0.8	0.031
G	6.0	0.236
H	16.0	0.63
I	18.7	0.736
J	6.0	0.236
K	16.0	0.63
L	18.7	0.736
M	8.2	0.323
O	8.0	0.315
N	2.5	0.098
P	2.0	0.079
Q	0.35	0.014
R	φ2.3	φ0.091
S	φ1.5	φ0.059

Figure B-3. EV-9200GC-80 Footprint (For Reference Only)

Based on EV-9200GC-80
(2) Pad drawing (in mm)



EV-9200GC-80-P1E

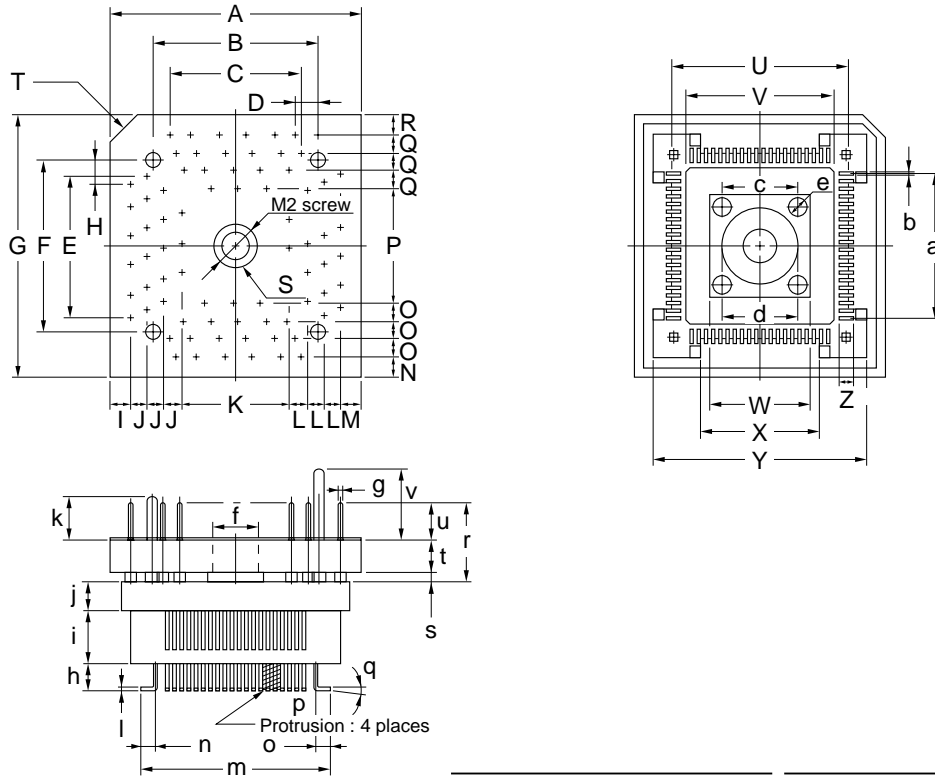
ITEM	MILLIMETERS	INCHES
A	19.7	0.776
B	15.0	0.591
C	$0.65 \pm 0.02 \times 19 = 12.35 \pm 0.05$	$0.026^{+0.001}_{-0.002} \times 0.748 = 0.486^{+0.003}_{-0.002}$
D	$0.65 \pm 0.02 \times 19 = 12.35 \pm 0.05$	$0.026^{+0.001}_{-0.002} \times 0.748 = 0.486^{+0.003}_{-0.002}$
E	15.0	0.591
F	19.7	0.776
G	6.0 ± 0.05	$0.236^{+0.003}_{-0.002}$
H	6.0 ± 0.05	$0.236^{+0.003}_{-0.002}$
I	0.35 ± 0.02	$0.014^{+0.001}_{-0.001}$
J	$\phi 2.36 \pm 0.03$	$\phi 0.093^{+0.001}_{-0.002}$
K	$\phi 2.3$	$\phi 0.091$
L	$\phi 1.57 \pm 0.03$	$\phi 0.062^{+0.001}_{-0.002}$

Caution Dimensions of mount pad for EV-9200 and that for target device (QFP) may be different in some parts. For the recommended mount pad dimensions for QFP, refer to "SEMICONDUCTOR DEVICE MOUNTING TECHNOLOGY MANUAL" (C10535E).

Drawing of Conversion Adapter (TGK-080SDW)

Figure B-4. TGK-080SDW Drawing (For Reference) (unit: mm)

TGK-080SDW (TQPACK080SD + TQSOCKET080SDW)
Package dimension (unit: mm)



ITEM	MILLIMETERS	INCHES	ITEM	MILLIMETERS	INCHES
A	18.0	0.709	a	0.5x19=9.5±0.10	0.020x0.748=0.374±0.004
B	11.77	0.463	b	0.25	0.010
C	0.5x19=9.5	0.020x0.748=0.374	c	φ5.3	φ0.209
D	0.5	0.020	d	φ5.3	φ0.209
E	0.5x19=9.5	0.020x0.748=0.374	e	φ1.3	φ0.051
F	11.77	0.463	f	φ3.55	φ0.140
G	18.0	0.709	g	φ0.3	φ0.012
H	0.5	0.020	h	1.85±0.2	0.073±0.008
I	1.58	0.062	i	3.5	0.138
J	1.2	0.047	j	2.0	0.079
K	7.64	0.301	k	3.0	0.118
L	1.2	0.047	l	0.25	0.010
M	1.58	0.062	m	14.0	0.551
N	1.58	0.062	n	1.4±0.2	0.055±0.008
O	1.2	0.047	o	1.4±0.2	0.055±0.008
P	7.64	0.301	p	h=1.8 φ1.3	h=0.071 φ0.051
Q	1.2	0.047	q	0 to 5°	0.000 to 0.197°
R	1.58	0.062	r	5.9	0.232
S	φ3.55	φ0.140	s	0.8	0.031
T	C 2.0	C 0.079	t	2.4	0.094
U	12.31	0.485	u	2.7	0.106
V	10.17	0.400	v	3.9	0.154
W	6.8	0.268			
X	8.24	0.324			
Y	14.8	0.583			
Z	1.4±0.2	0.055±0.008			

TGK-080SDW-G1E

Note Product by TOKYO ELETECH CORPORATION.

APPENDIX C EMBEDDED SOFTWARE

For efficient program development and maintenance of the μ PD78054, 78054Y Subseries, the following embedded software is available.

Real-time OS (1/2)

RX78K/0 Real-time OS	<p>A real-time OS conforming to μITRON specifications.</p> <p>Added with the tool (configurator) to create the RX78K/0 nucleus and multiple information table. Used in combination with separately available Assembler Package (RA78K/0) and Device File (DF78054).</p> <p><Precautions for the use in PC environment></p> <p>Real-time OS is a DOS-based application. Use it with DOS prompt on Windows.</p>
	Part number: μ SxxxxRX78013- $\Delta\Delta\Delta\Delta$

Caution When purchasing the RX78K/0, fill in the purchase application form in advance, and sign the License Agreement.

Remark xxxx and $\Delta\Delta\Delta\Delta$ in the part number differs depending on the host machine and OS used.

μ SxxxxRX78013- $\Delta\Delta\Delta\Delta$

$\Delta\Delta\Delta\Delta$	Product Outline	Max. No. for Use in Mass Production
001	Evaluation object	Do not use for mass production.
100K	Mass-production object	100,000
001M		1,000,000
010M		10,000,000
S01	Source program	Source program for mass-production object

xxxx	Host Machine	OS	Supply Media
AA13	PC-9800 series	Japanese Windows Notes1, 2	3.5-inch 2HD FD
AB13	IBM PC/AT and compatibles	Japanese Windows Notes1, 2	3.5-inch 2HC FD
BB13		English Windows Notes1, 2	
3P16	HP9000 series 700	HP-UX (Rel. 9.05)	DAT (DDS)
3K13	SPARCstation	SunOS (Rel. 4.1.4)	3.5-inch 2HC FD
3K15			1/4-inch CGMT
3R13	NEWS (RISC)	NEWS-OS (Rel. 6.1)	3.5-inch 2HC FD

Notes

1. Operates also in DOS environment.
2. Does not support WindowsNT.

Real-time OS (2/2)

MX78K0 OS	A μ ITRON specification subset OS. Added with MX78K0 nucleus. Performs task management, event management, and time management. In task management, controls the execution order of tasks and performs processing to change the task to the one executed next. <Precautions for the use in PC environment> The MX78K0 is a DOS-based application. Use it with DOS prompt on Windows.
	Part number: μ SxxxxMX78K0- $\Delta\Delta\Delta$

Remark xxxx and $\Delta\Delta\Delta$ in the part number differs depending on the host machine and OS used.

μ SxxxxMX78K0- $\Delta\Delta\Delta$

$\Delta\Delta\Delta$	Product outline	Max. No. for Use in Mass Production
001	Evaluation object	Use for preproduction.
xx	Mass-production object	Use for mass production.
S01	Source program	Can be purchased only when purchasing mass-produced object.

xxxx	Host Machine	OS	Supply Media
AA13	PC-9800 series	Japanese Windows Notes1, 2	3.5-inch 2HD FD
AB13	IBM PC/AT and compatibles	Japanese Windows Notes1, 2	3.5-inch 2HC FD
BB13		English Windows Notes1, 2	
3P16	HP9000 series 700	HP-UX (Rel. 9.05)	DAT (DOS)
3K13	SPARCstation	SunOS (Rel. 4.1.4)	3.5-inch 2HC FD
3K15			1/4-inch CGMT
3R13	NEWS (RISC)	NEWS-OS (Rel. 6.1)	3.5-inch 2HC FD

- Notes**
1. Operates also in DOS environment.
 2. Does not support WindowsNT.

APPENDIX D REGISTER INDEX

D.1 Register Index

8-bit timer mode control register (TMC1)	225
8-bit timer output control register (TOC1)	226
8-bit timer register 1 (TM1)	223
8-bit timer register 2 (TM2)	223
16-bit timer mode control register (TMC0)	184
16-bit timer output control register (TOC0)	186
16-bit timer register (TM0)	182
16-bit timer register (TMS)	223
[A]	
ADCR: A/D conversion result register	267
ADIS: A/D converter input select register	271
ADM: A/D converter mode register	269
ADTC: Automatic data transmit/receive control register	400, 411
ADTI: Automatic data transmit/receive interval specify register	401, 412
ADTP: Automatic data transmit/receive address pointer	396
ASIM: Asynchronous serial interface mode register	445, 453, 455, 478
ASIS: Asynchronous serial interface status register	447, 456
[B]	
BRGC: Baud rate generator control register	448, 457, 469
[C]	
CORAD0: Correction address register 0	538
CORAD1: Correction address register 1	538
CORCN: Correction control register	539
CR00: Capture/compare register 00	181
CR01: Capture/compare register 01	181
CR10: Compare registers 10	223
CR20: Compare registers 20	223
CRC0: Capture/compare control register 0	185
CSIM0: Serial operating mode register 0	296, 302, 315, 334, 350, 357, 382, 372
CSIM1: Serial operating mode register 1	396, 399, 409
CSIM2: Serial operating mode register 2	444, 452, 454, 467
[D]	
DACS0: D/A conversion value set register 0	283
DACS1: D/A conversion value set register 1	283
DAM: D/A converter mode register	284
[E]	
External interrupt mode register (INTM0)	189, 492
External interrupt mode register (INTM1)	272, 492

[I]	
IF0H:	Interrupt request flag register 0H 489
IF0L:	Interrupt request flag register 0L 489
IF1L:	Interrupt request flag register 1L 489, 508
IMS:	Memory size switching register 517, 549, 550
INTM0:	External interrupt mode register 189, 492
INTM1:	External interrupt mode register 272, 492
IXS:	Internal expansion RAM size switching register 551
	Interrupt mask flag register 0H (MK0H) 490
	Interrupt mask flag register 0L (MK0L) 490
	Interrupt mask flag register 1L (MK1L) 490, 508
	Interrupt timing specify register (SINT) 300, 318, 336, 354, 364, 375
[K]	
KRM:	Key return mode register 155, 509
[M]	
MK0H:	Interrupt mask flag register 0H 490
MK0L:	Interrupt mask flag register 0L 490
MK1L:	Interrupt mask flag register 1L 490, 508
MM:	Memory expansion mode register 154, 516
	Memory size switching register (IMS) 517, 549, 550
[O]	
OSMS:	Oscillation mode selection register 164
OSTS:	Oscillation stabilization time select register 516
[P]	
P0:	Port0 134
P1:	Port1 136
P2:	Port2 137, 139
P3:	Port3 141
P4:	Port4 142
P5:	Port5 143
P6:	Port6 144
P7:	Port7 146
P12:	Port12 148
P13:	Port13 149
PCC:	Processor clock control register 161
PM0:	Port mode register 0 150
PM1:	Port mode register 1 150
PM2:	Port mode register 2 150
PM3:	Port mode register 3 150, 188, 227, 259, 264
PM5:	Port mode register 5 150
PM6:	Port mode register 6 150
PM7:	Port mode register 7 150
PM12:	Port mode register 12 150, 480
PM13:	Port mode register 13 150

PROH:	Priority specify flag register 0H	491
PROL:	Priority specify flag register 0L	491
PR1L:	Priority specify flag register 1L	491
PSW:	Program status word	109, 496
PUOH:	Pull-up resistor option register H	153
PUOL:	Pull-up resistor option register L	153

[R]

RTBH:	Real-time output buffer register H	479
RTBL:	Real-time output buffer register L	479
RTPC:	Real-time output port control register	481
RTPM:	Real-time output port mode register	480
RXB:	Receive buffer register	443
RXS:	Receive shift register	443

[S]

SAR:	Successive approximation register	267
SBIC:	Serial bus interface control register	298, 304, 316, 335, 352, 358, 363, 373
SCS:	Sampling clock select register	190, 494
SFR:	Special-function register	114
SINT:	Interrupt timing specify register	300, 318, 336, 354, 364, 375
SIO0:	Serial I/O shift register 0	292, 346
SIO1:	Serial I/O shift register 1	396
SVA:	Slave address register	292, 346
Serial operating mode register 0 (CSIM0)	296, 302, 315, 334, 350, 357, 362, 372	
Serial operating mode register 1 (CSIM1)	396, 399, 409	
Serial operating mode register 2 (CSIM2)	444, 452, 454, 467	

[T]

TCL0:	Timer clock select register 0	182, 257
TCL1:	Timer clock select register 1	223
TCL2:	Timer clock select register 2	242, 250, 262
TCL3:	Timer clock select register 3	294, 348, 397
TM0:	16-bit timer register	182
TM1:	8-bit timer register 1	223
TM2:	8-bit timer register 2	223
TMC0:	16-bit timer mode control register	184
TMC1:	8-bit timer mode control register	225
TMC2:	Watch timer mode control register	245
TMS:	16-bit timer register	223
TOC0:	16-bit timer output control register	186
TOC1:	8-bit timer output control register	226
TXS:	Transmit shift register	443

[W]

WDTM:	Watchdog timer mode register	252
Watch timer mode control register (TMC2)	245	

[MEMO]

APPENDIX E REVISION HISTORY

Major revisions by edition and revised chapters are shown below.

Edition	Major revisions from previous version	Revised Chapters
2nd	P40/AD0-P47/AD7 pin I/O circuit types were changed. Connection method of unused AV _{REF1} pin was changed.	CHAPTER 2 Pin Functions
	Caution on OVFO flag operations was added.	CHAPTER 6 16-Bit Timer/Event Counter
	Interval time of interval timer was corrected.	CHAPTER 8 Watch Timer
	Buzzer output frequency was corrected.	CHAPTER 11 Buzzer Output Control Circuit
	Description of settings of port mode register and output latch was added.	CHAPTER 14 Serial Interface Channel 0
		CHAPTER 15 Serial Interface Channel 1
		CHAPTER 16 Serial Interface Channel 2
Paragraph (2), "Memory size switching register (IMS)" was added in section 19.2.	CHAPTER 19 External Device Expansion Function	
Embedded software were added.	APPENDIX B Embedded Software	
3rd	μ PD78055 and 78P058 were added as new devices. μ PD78054Y subseries devices were added.	Throughout the manual
	Pin I/O circuits and unused pin connections were changed.	CHAPTER 3 Pin Function (μ PD78054 Subseries)
	Caution on oscillation mode switching was added.	CHAPTER 7 Clock Generator
	Parts of list of maximum required time for switching CPU clock types were corrected.	
	Available frequencies for 16-bit timer register count clock were changed.	CHAPTER 8 16-bit Timer/Event Counter
	Caution on pulse width measurement operations was added.	
	Timing chart for one-shot pulse output operation was corrected.	
	Section 15.4, "Operations of D/A Converter," was added.	CHAPTER 15 D/A Converter
	Section 15.5, "Cautions Related to D/A Converter," was added.	
	Condition under which acknowledge detection flag (ACKD) is cleared was changed.	CHAPTER 16 Serial Interface Channel 0 (μ PD78054 Subseries)
	Timing chart for RELD and CMDD operations (slave) was corrected.	
	Description on automatic transmit/receive interval time was corrected.	CHAPTER 18 Serial Interface Channel 1
	List of operation mode settings was corrected.	CHAPTER 19 Serial Interface Channel 2
	Flowchart for non-maskable interrupt acknowledgement was corrected.	CHAPTER 21 Interrupt and Test Functions
	Oscillation stabilization time after RESET input was corrected.	CHAPTER 23 Standby Function
	ROM correction chapter was added.	CHAPTER 25 ROM Correction
Caution on write address specification in PROM programming mode was added.	CHAPTER 26 μ PD78P054, 78P058	

APPENDIX E REVISION HISTORY

Edition	Major revisions from previous version	Revised Chapters
4th edition	Addition of following package to all devices: <ul style="list-style-type: none"> • 80-pin plastic QFP (14 × 14 mm, resin thickness: 1.4 mm) (under planning) Addition of following package to μ PD78058 <ul style="list-style-type: none"> • 80-pin plastic TQFP (fine pitch) (12 × 12 mm) 	Throughout
	Addition of description to Caution in Figure 8-6. 16-Bit Timer Output Control Register Format	CHAPTER 8 16-BIT TIMER/EVENT COUNTER
	Change of Figure 11-3. Watchdog Timer Mode Register Format and addition of Note and Caution	CHAPTER 11 WATCHDOG TIMER
	Addition of caution on serial I/O shift register 0 (SIO0) of μ PD78054Y subseries	CHAPTER 17 SERIAL INTERFACE CHANNEL 0 (μ PD78054Y Subseries)
	Correction of Figure 17-22. Data Transmission from Master to Slave (Both Master and Slave Selected 9-Clock Wait)	
	Correction of Figure 17-23. Data Transmission from Slave to Master (Both Master and Slave Selected 9-Clock Wait)	
	Addition of (3) Slave wait release (slave reception) to 17.4.5 Cautions on use of I²C bus mode	
	Addition of 17.4.6 Restrictions in I²C bus mode	
	Addition of Caution to Figure 18-5. Automatic Data Transmit/Receive Interval Specify Register Format	CHAPTER 18 SERIAL INTERFACE CHANNEL 1
	Addition of Caution to 18.4.3 (3) (d) Busy control option	
	Addition of description on port mode register 12 (PM12)	CHAPTER 20 REAL-TIME OUTPUT PORT
	Addition of following products: IE-78000-R-A, IE-70000-98-IF-B, IE-70000-98N-IF, IE-70000-PC-IF-B, IE-78000-R-SV3, SM78K0, ID78K0, MX78K0 Addition of IBM PC/AT compatible machine as host machine Change of supported OS version	APPENDIX A DEVELOPMENT TOOLS APPENDIX B EMBEDDED SOFTWARE
	Addition of APPENDIX C REGISTER INDEX	APPENDIX C REGISTER INDEX

APPENDIX E REVISION HISTORY

Edition	Major revisions from previous version	Revised Chapters
4th edition	<p>The μPD78052(A),78053(A), and 78054(A) were added to the applicable types.</p> <p>The μPD78P054Y was deleted from the applicable types.</p> <p>The following package was deleted from the μPD78052, 78053, 78054, 78055, 78056, 78058, 78P058, 78054Y Subseries:</p> <ul style="list-style-type: none"> • 80-pin plastic QFP (14 × 14 mm, resin thickness 2.7 mm) 	Throughout
	Figure 9-10. Square-Wave Output Operation Timing was added.	CHAPTER 9 8-BIT TIMER/EVENT COUNTER
	Figure 9-13. Square-Wave Output Operation Timing was added.	
	Note was added to Figure 16-4. Serial Operating Mode Register 0 Format .	CHAPTER 16 SERIAL INTERFACE CHANNEL 0 (μ PD78054 Subseries)
	(4) Synchronization control and (5) Automatic transmit/receive Interval time were added to 18.4.3 3-wire serial I/O mode operation with automatic transmit/receive function .	CHAPTER 18 SERIAL INTERFACE CHANNEL 1
	Precaution was added to 19.1 (3) 3-wire serial I/O mode (MSB-/LSB-first switchable) .	CHAPTER 19 SERIAL INTERFACE CHANNEL 2
	Figure 19-3. Serial Operating Mode Register 2 Format was changed.	
	Table 19-2. Serial Interface Channel 2 Operating Mode Settings was changed.	
	Figure 19-10. Receive Error Timing was corrected.	
	19.4.4 Limitations when UART mode is used was added.	
	APPENDIX A DIFFERENCES BETWEEN μPD78054, 78054Y SUBSERIES AND μPD78058F,78058FY SUBSERIES was added.	APPENDIX A DIFFERENCES BETWEEN μ PD78054, 78054Y SUBSERIES AND μ PD78058F,78058FY SUBSERIES
	APPENDIX B DEVELOPMENT TOOL Entire revision: Support for in-circuit emulator IE-78K0-NS	APPENDIX B DEVELOPMENT TOOL
	APPENDIX C EMBEDDED SOFTWARE Entire revision: Deletion of fuzzy inference development support system	APPENDIX C EMBEDDED SOFTWARE

[MEMO]

Facsimile Message

From:

Name

Company

Tel.

FAX

Address

Although NEC has taken all possible steps to ensure that the documentation supplied to our customers is complete, bug free and up-to-date, we readily accept that errors may occur. Despite all the care and precautions we've taken, you may encounter problems in the documentation. Please complete this form whenever you'd like to report errors or suggest improvements to us.

Thank you for your kind support.

North America

NEC Electronics Inc.
Corporate Communications Dept.
Fax: 1-800-729-9288
1-408-588-6130

Hong Kong, Philippines, Oceania

NEC Electronics Hong Kong Ltd.
Fax: +852-2886-9022/9044

Asian Nations except Philippines

NEC Electronics Singapore Pte. Ltd.
Fax: +65-250-3583

Europe

NEC Electronics (Europe) GmbH
Technical Documentation Dept.
Fax: +49-211-6503-274

Korea

NEC Electronics Hong Kong Ltd.
Seoul Branch
Fax: 02-528-4411

Japan

NEC Semiconductor Technical Hotline
Fax: 044-548-7900

South America

NEC do Brasil S.A.
Fax: +55-11-6465-6829

Taiwan

NEC Electronics Taiwan Ltd.
Fax: 02-719-5951

I would like to report the following error/make the following suggestion:

Document title: _____

Document number: _____ Page number: _____

If possible, please fax the referenced page or drawing.

Document Rating	Excellent	Good	Acceptable	Poor
Clarity	<input type="checkbox"/>	<input type="checkbox"/>	<input type="checkbox"/>	<input type="checkbox"/>
Technical Accuracy	<input type="checkbox"/>	<input type="checkbox"/>	<input type="checkbox"/>	<input type="checkbox"/>
Organization	<input type="checkbox"/>	<input type="checkbox"/>	<input type="checkbox"/>	<input type="checkbox"/>