

PROPRIETARY INFORMATION
 NOT TO BE RELEASED
 WITHOUT WRITTEN PERMISSION
 FROM AN AUTHORIZED
 REPRESENTATIVE OF
 APPLIED ENGINEERING PRODUCTS

REVISIONS			
REV	DESCRIPTION	DATE	APPROVED
-	INITIAL RELEASE	06/02/03	G.A.T.

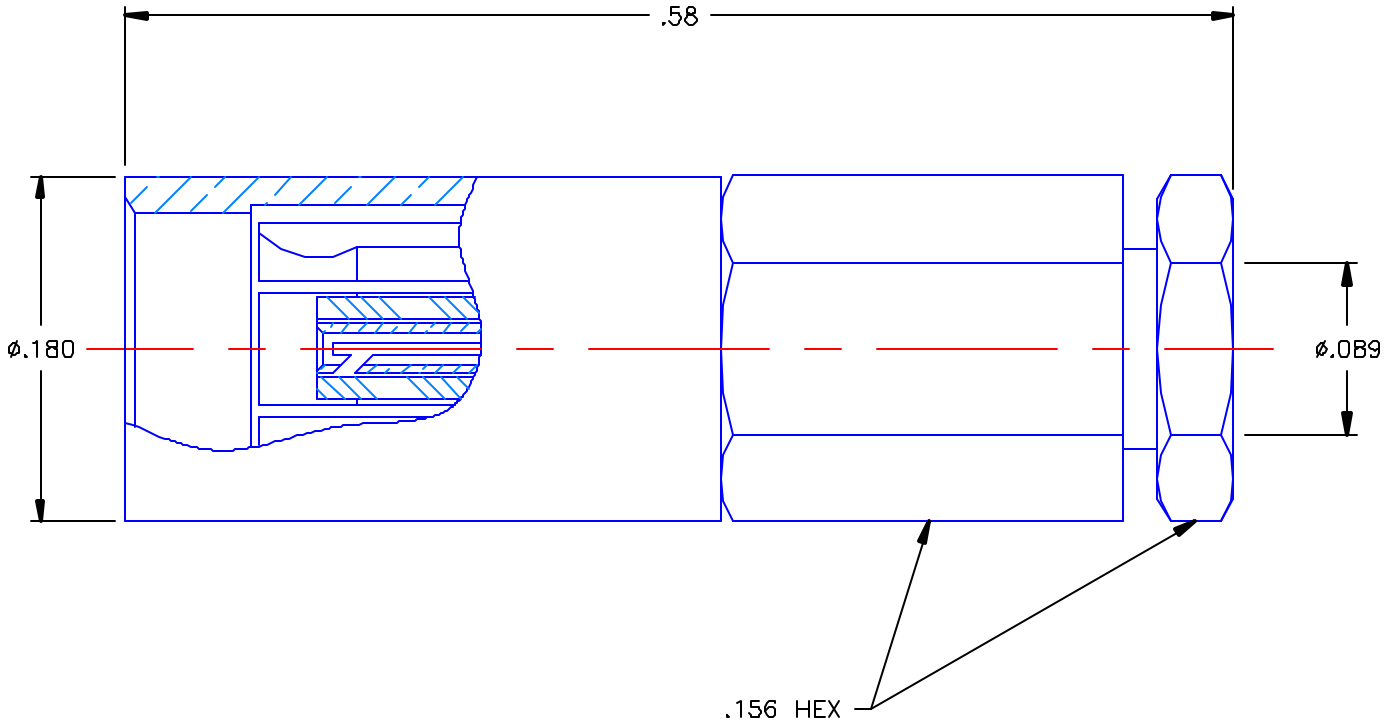

NOTES:

MATERIALS:

1. BODY & CONTACT = BERYLLIUM COPPER PER ASTM B196, ALLOY C17300, TEMPER TD04.
2. INSULATORS = VIRGIN WHITE TEFLON PER ASTM D1710, GRADE 1, TYPE I, CLASS "B".
3. ALL OTHER METAL PARTS = BRASS PER ASTM B16, ALLOY C36000, TEMPER H02.

FINISHES:

1. CONTACT = GOLD PLATE PER MIL-G-45204, TYPE II, CLASS 1, GRADE C, OVER .00010 TO .00020 STRESS FREE SULFAMATE NICKEL PER QQ-N-290.
2. ALL OTHER METAL PARTS = GOLD PLATE PER MIL-G-45204, TYPE II, CLASS 0, GRADE C, OVER .00010 TO .00020 COPPER STRIKE PER MIL-C-14550.

UNLESS OTHERWISE SPECIFIED DIMENSIONS ARE IN INCHES TOLERANCES ON		DWN: G.A.T.	DATE 06/02/03	 APPLIED ENGINEERING PRODUCTS 104 John W Murphy Dr. New Haven, CT 06513				
		CHKD: D.N.	DATE 06/02/03					
DECIMAL	ANGLE	APVD: D.J.C.	DATE 06/02/03	SSMC "PUSH-ON" FEMALE PLUG SOLDER CLAMP TYPE TO .086 S/R				
REFERENCE:		MATERIALS & FINISHES: SEE NOTES			<table border="1"> <tr> <td>SIZE A</td> <td>FSCM NO. 19505</td> <td>DWG NO. 7202-1542-510</td> <td>REV -</td> </tr> </table>	SIZE A	FSCM NO. 19505	DWG NO. 7202-1542-510
SIZE A	FSCM NO. 19505	DWG NO. 7202-1542-510	REV -					
ORIGINATOR: G.A.T. DATE: 06/02/03		SCALE 10:1		<table border="1"> <tr> <td>CODE</td> <td>SHEET 1 OF 1</td> </tr> </table>	CODE	SHEET 1 OF 1		
CODE	SHEET 1 OF 1							

/202-1542-510