

Dual, 12-Bit, Voltage Output D/A Converter

- Two 12-bit DAC's on a Single Chip
- Low Power — 40 mW (20mW/DAC)
- Double-Buffered Inputs
- Voltage Outputs
- Midscale Preset, Zero Volts Out
- 1MHz 4-Quadrant Multiplying Bandwidth
- Separate Reference Inputs
- 28-pin PLCC, SOIC and Plastic DIP Packages

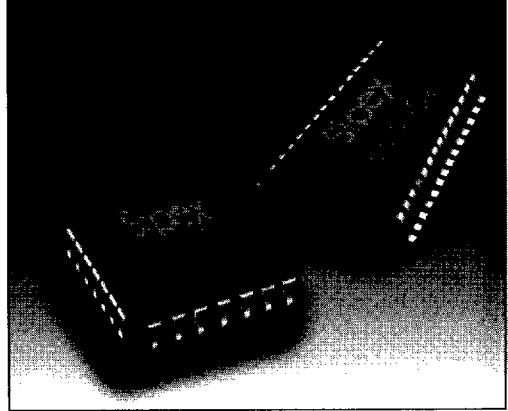

DESCRIPTION...

The **SP9502** is a low power, dual version of the popular SP9345, Quad 12-Bit Digital-to-Analog Converter. It features $\pm 4.5V$ output swings when using $\pm 5V$ supplies. The converter is double-buffered for easy microprocessor interface. Each 12-bit DAC is independently addressable and may be simultaneously updated using a single transfer command. The output settling-time is specified at $4\mu s$. The **SP9502** is available in 28-pin PLCC, SOIC and DIP packages, specified over commercial and industrial temperature ranges.

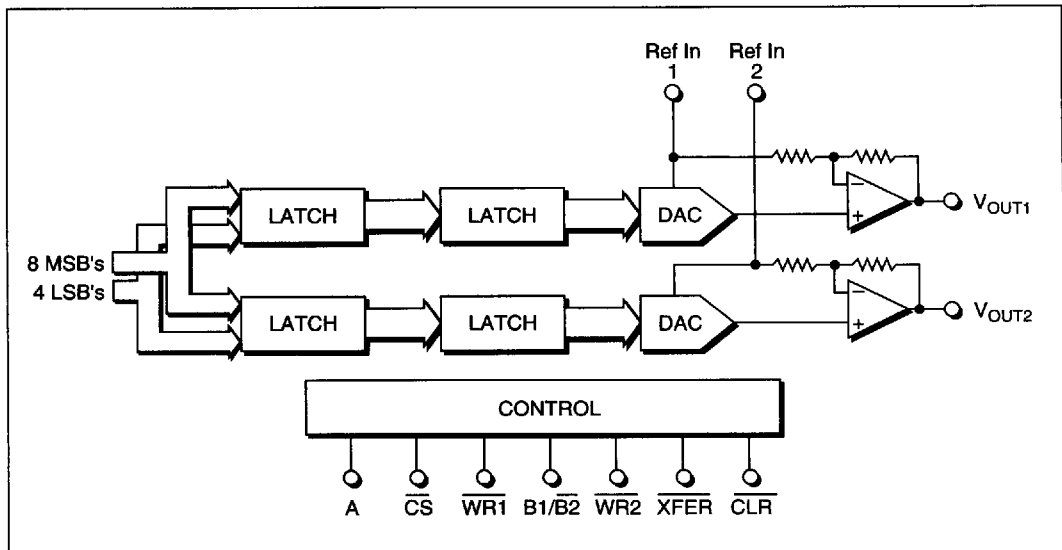

ABSOLUTE MAXIMUM RATINGS

These are stress ratings only and functional operation of the device at these or any other above those indicated in the operation sections of the specifications below is not implied. Exposure to absolute maximum rating conditions for extended periods of time may affect reliability.

V_{DD} - GND	-0.3V, +6.0V
V_{SS} - GND	+0.3V, -6.0V
V_{DD} - V_{SS}	-0.3V, +12.0V
V_{REF}	V_{SS}^* , V_{DD}
D_{IN}	V_{SS}^* , V_{DD}
Power Dissipation	
Plastic DIP	375mW
(derate 7mW/°C above +70°C)	
Plastic LCC	375mW
(derate 7mW/°C above +70°C)	
Small Outline	375mW
(derate 7mW/°C above +70°C)	



CAUTION:
ESD (ElectroStatic Discharge) sensitive device. Permanent damage may occur on unconnected devices subject to high energy electrostatic fields. Unused devices must be stored in conductive foam or shunts. Personnel should be properly grounded prior to handling this device. The protective foam should be discharged to the destination socket before devices are removed.

SPECIFICATIONS

(Typical at 25°C, $T_{MIN} \leq T_A \leq T_{MAX}$; $V_{DD} = +5V$, $V_{SS} = -5V$, $V_{REF} = +3V$; CMOS logic level digital inputs; specifications apply to all grades unless otherwise noted.)

PARAMETER	MIN.	TYP.	MAX.	UNITS	CONDITIONS
DIGITAL INPUTS					
Logic Levels					
V_{IH}	2.4			Volts	
V_{IL}			0.8	Volts	
4 Quad, Bipolar Coding		Offset Binary			
REFERENCE INPUT					
Voltage Range		±3	±4.5	Volts	
Input Resistance	6	8.8		kΩ	$D_{IN} = 1877$, code dependent
SWITCHING CHARACTERISTICS					
Strobe Width	120			ns	
Data Set-up Time	125			ns	
Data Hold Time	0			ns	
ANALOG OUTPUT					
Gain					
-B, -K		±0.5	±2.0	LSB	$V_{REF} = ±3V$; Note 3
-A, -J		±1.0	±4.0	LSB	$V_{REF} = ±3V$; Note 3
		±1.0	±5.0	LSB	$V_{REF} = ±4.5V$; Note 3
Initial Offset Bipolar		±0.25	±3.0	LSB	$D_{IN} = 2,048$
Voltage Range Bipolar		±3.0	±4.5	Volts	
Output Current	±5.0			mA	$V_{REF} = ±3V$
	±0.5			mA	$V_{REF} = ±4.5V$
STATIC PERFORMANCE					
Resolution	12			Bits	
Integral Linearity					
-B, -K		±0.25	±0.5	LSB	$V_{REF} = ±3V$; Note 3
-A, -J		±0.5	±1.0	LSB	$V_{REF} = ±3V$; Note 3
		±0.5	±3.0	LSB	$V_{REF} = ±4.5V$; Note 3
Differential Linearity					
-B, -K		±0.25	±0.75	LSB	
-A, -J		±0.25	±1.0	LSB	
Monotonicity		Guaranteed			
DYNAMIC PERFORMANCE					
Settling Time					
Small Signal		0.5		μs	to 0.012%
Full Scale		4		μs	to 0.012%
Slew Rate		4		V/μs	

SPECIFICATIONS (continued)

(Typical at 25°C, $T_{MIN} \leq T_A \leq T_{MAX}$; $V_{DD} = +5V$, $V_{SS} = -5V$, $V_{REF} = +3V$; CMOS logic level digital inputs; specifications apply to all grades unless otherwise noted.)

PARAMETER	MIN.	TYP.	MAX.	UNITS	CONDITIONS
STABILITY					
Gain		15		ppm/°C	t_{MIN} to t_{MAX}
Bipolar Zero		15		ppm/°C	t_{MIN} to t_{MAX}
POWER REQUIREMENTS					
V_{DD}					+5V, ±3%; Note 4
-J, -K		4	6	mA	
-A, -B		4	8	mA	
V_{SS}					-5V, ±3%; Note 4
-J, -K		4	6	mA	
-A, -B		4	8	mA	
Power Dissipation		40		mW	
ENVIRONMENTAL AND MECHANICAL					
Operating Temperature					
-J, -K	0		+70	°C	
-A, -B	-40		+85	°C	
Storage Temperature	-60		+150	°C	
Package					
_N		28-pin Plastic DIP			
_L		28-pin Plastic LCC			
_S		28-pin SOIC			

Notes:

1. Integral Linearity, for the **SP9502**, is measured as the arithmetic mean value of the magnitudes of the greatest positive deviation and the greatest negative deviation from the theoretical value for any given input condition.
2. Differential Linearity is the deviation of an output step from the theoretical value of 1 LSB for any two adjacent digital input codes.
3. 1 LSB = $2 \cdot V_{REF} / 4,096$.
4. $V_{REF} = 0V$.

PINOUT — 28-PIN PLASTIC LCC

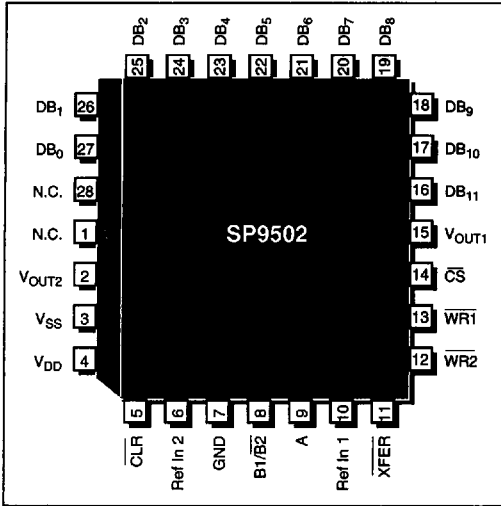

PINOUT — 28-PIN SOIC & DIP

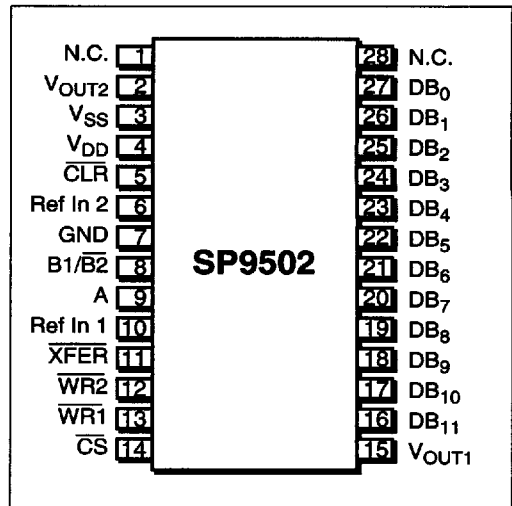

PIN ASSIGNMENTS

- Pin 1 — N.C. — No Connection.
- Pin 2 — V_{OUT2} — Voltage Output from DAC2.
- Pin 3 — V_{SS} — -5V Power Supply Input.
- Pin 4 — V_{DD} — +5V Power Supply Input.
- Pin 5 — \overline{CLR} — Clear. Gated with \overline{XFER} (pin 11). Active low. Clears both DAC outputs to 0V.
- Pin 6 — REF IN2 — Reference Input for DAC2.
- Pin 7 — GND — Ground.
- Pin 8 — $B1/\overline{B2}$ — Byte 1/Byte 2 — Selects Data Input Format. A logic "1" on pin 8 selects the 12-bit mode, and all 12 data bits are presented to the DAC(s) unchanged; a logic "0" selects the 8-bit mode, and the four LSBs are connected to the four MSBs, allowing an 8-bit MSB-justified interface.
- Pin 9 — A — Address for DAC Selection — A logic "0" selects DAC 1; a logic "1" selects DAC 2.
- Pin 10 — REF IN1 — Reference Input for DAC1.
- Pin 11 — \overline{XFER} — Transfer. Gated with $\overline{WR2}$ (pin 12); loads all DAC registers simultaneously. Active low.
- Pin 12 — $\overline{WR2}$ — Write Input 2 — In conjunction with \overline{XFER} (pin 11), controls the transfer of data

from the first set of latches to the second. In conjunction with \overline{CLR} , the second latch is reset to all 0's, and the DAC output will settle to 0V output.

Pin 13 — $\overline{WR1}$ — Write Input 1 — In conjunction with Chip Select (pin 14), enables DAC selection, and controls the transfer of data from the input bus to the first set of latches.

Pin 14 — \overline{CS} — Chip Select — Enables writing data to input latches and/or transferring data from input to secondary latches, and DAC(s).

Pin 15 — V_{OUT1} — Voltage Output from DAC1.

Pin 16 — DB_{11} — Data Bit 11.

Pin 17 — DB_{10} — Data Bit 10.

Pin 18 — DB_9 — Data Bit 9.

Pin 19 — DB_8 — Data Bit 8.

Pin 20 — DB_7 — Data Bit 7.

Pin 21 — DB_6 — Data Bit 6.

Pin 22 — DB_5 — Data Bit 5.

Pin 23 — DB_4 — Data Bit 4.

Pin 24 — DB_3 — Data Bit 3.

Pin 25 — DB_2 — Data Bit 2.

Pin 26 — DB_1 — Data Bit 1.

Pin 27 — DB₀ — Data Bit 0.

Pin 28 — N.C. — No Connection.

FEATURES...

The **SP9502** is a low power, dual version of the popular SP9345, Quad 12-Bit Digital-to-Analog Converter. This Dual, Voltage Output, 12-Bit Digital-to-Analog Converter features $\pm 4.5V$ output swings when using $\pm 5V$ supplies. The input coding format used is standard offset binary. (Refer to *Table 1* below.)

The converter utilizes double-buffering on each of the 12 parallel digital inputs, for easy microprocessor interface. Each 12-bit DAC is independently addressable and may be simultaneously updated using a single \overline{XFER} command. The output settling-time is specified at $4\mu s$ to full 12-bit accuracy when driving a 5Kohm, 50pf load combination. The **SP9502**, Dual 12-Bit Digital-to-Analog Converter is ideally suited for applications such as ATE, process controllers, robotics, and instrumentation. The **SP9502** is available in 28-pin plastic leadless chip carrier (PLCC) or SOIC and plastic DIP packages, specified over the commercial ($0^{\circ}C$ to $+70^{\circ}C$) and industrial ($-40^{\circ}C$ to $+85^{\circ}C$) temperature ranges.

THEORY OF OPERATION

The **SP9502** consists of five main functional blocks — input data multiplexer, DAC registers, control logic, two 12-bit D/A converters, and two bipolar output voltage amplifiers. The input data multiplexer is designed to interface to either 12- or 8-bit microprocessor data busses. The data selection (width) accepted by the **SP9502** is controlled by

INPUT			OUTPUT
MSB	LSB		
1111	1111	1111	VREF - 1 LSB
1111	1111	1110	VREF - 2 LSB
1000	0000	0001	0 + 1 LSB
1000	0000	0000	0
0000	0000	0001	0 + 1 LSB
0000	0000	0000	-VREF
$1 \text{ LSB} = \frac{2V_{REF}}{2^{12}}$			

Table 1. Offset Binary Coding

the $B1/\overline{B2}$ signal — a logic “1” selects the 12-bit mode, while a logic “0” selects the 8-bit mode. In the 12-bit mode the data is transferred to the DAC registers without changes in its format. In the 8-bit mode, the four least significant bits (LSBs) are connected to the four most significant bits (MSBs), allowing an 8-bit MSB-justified interface. All data inputs are enabled using the CS signal in both modes. The digital inputs are designed to be both TTL and 5V CMOS compatible.

In order to reduce the DAC full scale output sensitivity to the large weighting of the MSB's found in conventional R-2R resistor ladders, the 3 MSB's are decoded into 8 equally weighted levels. This reduces the contribution of each bit by a factor of 4, thus, reducing the output sensitivity to mismatches in resistors and switches by the same amount. Linearity errors and stability are both improved for the same reasons.

Each D/A converter is separated from the data bus by two sets of registers, each consisting of level-triggered latches. The first set is the input register and is 12-bits wide. This register is selected by the address input A and is enabled by the \overline{CS} and $\overline{WR1}$ signals. In the 8-bit mode, the enable signal to the 8 MSB's is disabled by a logic low on $B1/\overline{B2}$ to allow the 4 LSB's to be updated. The second register, which accepts the decoded 3 MSB's plus the 9 LSB's, is 16-bits wide. The two secondary registers are updated simultaneously for all DAC's using the \overline{XFER} and $\overline{WR2}$ signals. Using the \overline{CLR} and $\overline{WR2}$ signals or the power-on-reset, (enabled when the power is switched on) the second register is set to all 0's and the DAC output will settle to 0V.

Using the control logic block inputs, the user has full control of address decoding, chip enable, data transfer and clearing of the DAC's. The logic inputs are level triggered, and like the digital code inputs, are TTL and CMOS compatible. The truth table (*Table 2*) shows the appropriate functions associated with the states of the inputs.

The DACs themselves are implemented with a precision thin-film resistor network and CMOS transmission gate switches. Each D/A converter is used to convert the 12-bit input from the second storage register to a precision voltage.

The bipolar voltage output of the **SP9502** is cre-

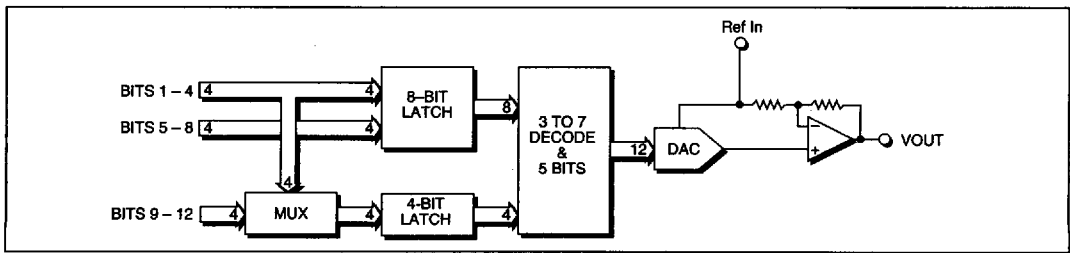

Figure 1. Detailed Block Diagram (only one DAC shown)

ated on-chip from the DAC Voltage Output (V_{DAC}) by using an operational amplifier and two feedback resistors connected as shown in Figure 2. This configuration produces a $\pm 4.5V$ bipolar output with standard offset binary coding. (See Table 1.)

USING THE SP9502

Loading Data

The sequence necessary to load a 12-bit word on a 12-bit wide data bus is as follows:

- 1) Set $\overline{XFER}=1, B1/\overline{B2}=1, \overline{CLR}=1, \overline{WR1}=1, \overline{WR2}=1, \overline{CS}=1$.
- 2) Set A (the DAC address) to the desired DAC — 0 = DAC₁; 1 = DAC₂.
- 3) Set D11 (MSB) through D0 (LSB) to the desired digital input code.
- 4) Load the word to the selected DAC by cycling $\overline{WR1}$ and \overline{CS} through the following sequence:
"1" — "0" — "1"
- 5) Repeat sequence for each register.

To load a 12-bit word to the input register of each DAC, using an 8-bit data bus, the sequence is as follows:

- 1) Set $\overline{XFER}=1, B1/\overline{B2}=1, \overline{CLR}=1, \overline{WR1}=1, \overline{WR2}=1, \overline{CS}=1$.
- 2) Set D11 through D4 to the 8 MSB's of the desired digital input code.
- 3) Load the 8 MSB's of the digital word to the selected input register by cycling $\overline{WR1}$ and \overline{CS} through the "1" — "0" — "1" sequence.
- 4) Reset B1/ $\overline{B2}$ from "1" — "0".
- 5) Set D11 (MSB) through D8 to the 4 LSB's of the digital input code.
- 6) Load the 4 LSB's by cycling $\overline{WR1}$ and \overline{CS} through the "1" — "0" — "1" sequence.

To transfer the four 12-bit words in the four input registers to the DAC registers:

- 1) Set $\overline{CLR}=1, \overline{CS}=1, \overline{WR1}=1$.
- 2) Cycle $\overline{WR2}$ and \overline{XFER} through the "1" — "0" — "1" sequence.

To "zero" the outputs of the two DAC's, cycle $\overline{WR2}$ and \overline{CLR} through the "1" — "0" — "1" sequence.

A	CS	WR1	B1/B2	WR2	XFER	CLR	FUNCTION
0	0	0	1	1	X	X	Address DAC 1 and load input register
0	0	0	0	1	X	X	Address DAC 1 and load 4 LSBs
1	0	0	1	1	X	X	Address DAC 2 and load input register
1	0	0	0	1	X	X	Address DAC 2 and load 4 LSBs
X	**	**	X	0	0	1	Transfer data from input register to DACs
X	X	X	X	0	X	0	Clears all DAC output voltages to 0V
X	1	X	X	X	X	X	Invalid state with any other control line active
X	X	1	X	X	X	X	Invalid state with any other control line active

X = Don't care; ** = Don't care; however, \overline{CS} and $\overline{WR1} = 1$ will inhibit changes to the input registers.

Table 2. Control Truth Table

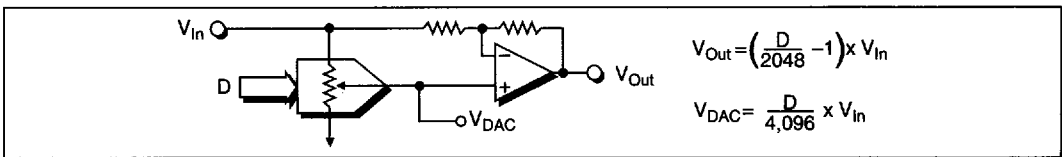

Figure 2. Transfer Function

Two Latches, One Latch, or No Latches

The latches can be used in a “semi-” transparent mode, and a “fully-” transparent mode. In order to use the SP9502 in either mode the user must be interfaced to a 12-bit bus only.

The semi-transparent mode is set up such that the first set of latches is transparent and the second set is used to latch the incoming data. Data is latched into the second set rather than the first set, in order to minimize glitch energy

induced from the data formatting. In this mode, $\overline{WR1}$ and \overline{CS} are tied low, and $\overline{WR2}$ and \overline{XFER} are used to strobe the data to the DAC's. Each DAC is addressed using the address line A. After the appropriate DAC has been selected and the data is settled at the digital inputs, bringing $\overline{WR2}$ and \overline{XFER} low will transfer the data to the DAC's. The user should be sure to bring \overline{XFER} and $\overline{WR2}$ high again so that the next selected DAC will not be overwritten by the last digital code. By strobing \overline{XFER} and $\overline{WR2}$, both

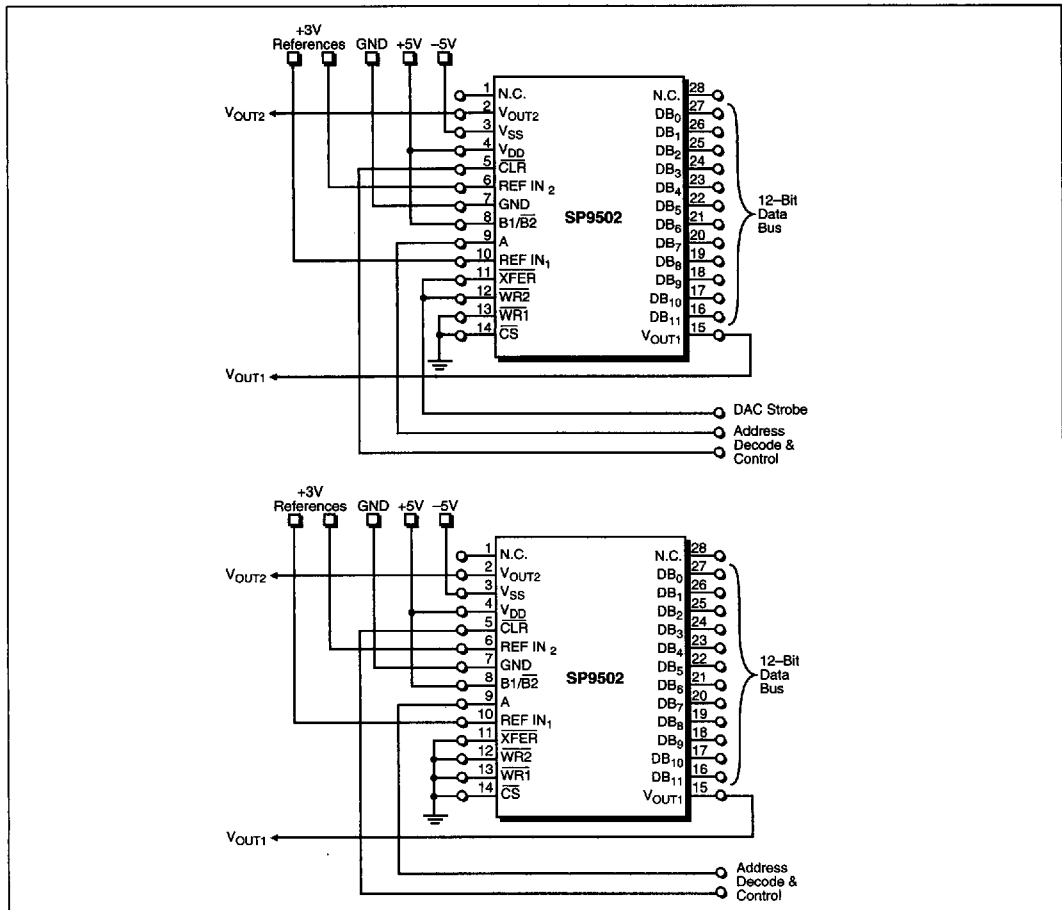

Figure 3. Latch Control Options — (Top) Semi-Transparent Latch Mode; (Bottom) Fully-Transparent Latch Mode

DAC's will be updated simultaneously. This mode of operation may be useful in applications where preloading of the input registers is not necessary.

A fully transparent mode is realized by typing $\overline{WR1}$, \overline{CS} , $\overline{WR2}$, and \overline{XFER} all low. In this mode, anything that is written on the 12-bit data bus will be passed directly to the selected DAC. Since both latches are not being used, the previous digital word will be overwritten by the new data as soon as the address changes and the data bus is switched to the appropriate DAC. This may be useful should the user want to calibrate a circuit, by taking full scale or zero scale readings for all four DAC's.

Zeroing DAC Outputs

The DAC outputs can be set to zero volts two

different ways. The first involves the \overline{CLR} and $\overline{WR2}$ pins. In normal operation, the \overline{CLR} pin is tied high, thus, disabling the clear function. When this pin is brought low with $\overline{WR2}$, a digital code of 1000 0000 0000 is written to both DAC inputs, producing a half scale output or zero volts. When the \overline{CLR} pin is brought back high, the digital code at the second register will again appear at the DAC digital input, and the analog output will return to its previous corresponding value. The second utilizes the built in power-on-reset. Using this feature, the **SP9502** can be configured such that during power-up, the second latch will be digitally "zeroed", producing a zero volt output at both DAC outputs. This is achieved by powering the unit up with \overline{XFER} in a high state. Thus, with no external circuitry, the **SP9502** can be powered up with the analog outputs at a known, zero volt output level.

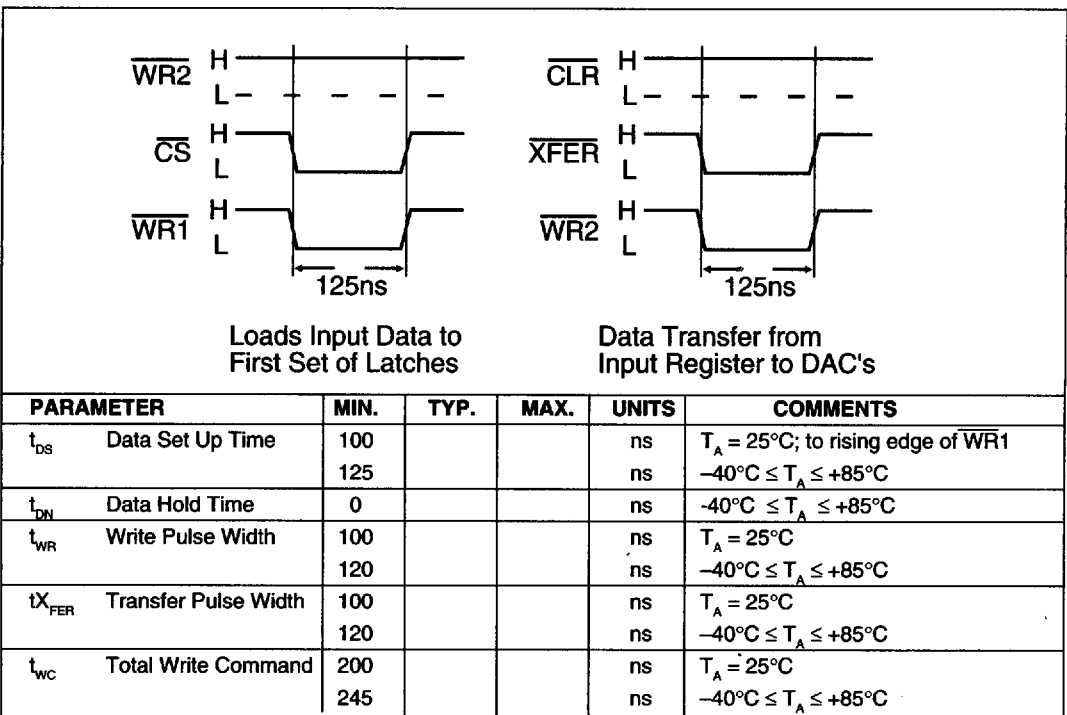

Figure 4. Timing

ORDERING INFORMATION

Model	Temperature Range	Package
Monolithic 12-Bit Dual DAC Voltage Output:		
SP9502JN	0°C to +70°C	28-pin, 0.3" Plastic DIP
SP9502KN	0°C to +70°C	28-pin, 0.3" Plastic DIP
SP9502JL*	0°C to +70°C	28-pin PLCC
SP9502KL*	0°C to +70°C	28-pin PLCC
SP9502JS	0°C to +70°C	28-pin, 0.3" SOIC
SP9502KS	0°C to +70°C	28-pin, 0.3" SOIC
SP9502AN	-40°C to +85°C	28-pin, 0.3" Plastic DIP
SP9502BN	-40°C to +85°C	28-pin, 0.3" Plastic DIP
SP9502AL*	-40°C to +85°C	28-pin PLCC
SP9502BL*	-40°C to +85°C	28-pin PLCC
SP9502AS	-40°C to +85°C	28-pin, 0.3" SOIC
SP9502BS	-40°C to +85°C	28-pin, 0.3" SOIC

*Consult Factory