

8-BIT MCU FOR PRESET REMOTE CONTROL (OTP TYPE)

DESCRIPTION

SC65D02P40 is a preset universal remote control transmitter which uses Silan's 8-bit MCU core SC65X. It integrates 8K-byte ROM, 32K-byte OTP memory and special code transmitting module, so a preset universal remote solution can be easily achieved only with a few periphery components. It can preset hundreds of different remote codes and data to control a plurality of home electric appliances.

Because of the embedded powerful code transmitting programs in ROM and together with affiliated PC software assistant design and test, the R&D cycle and workload can be greatly reduced, and the reliability of the product can be improved.

Another universal remote control transmitter SC65D02C40 of Silan has built-in 40K ROM and it is compatible with SC65D02P40 in memory total capacity and function. The program developed on SC65D02P40 can be directly used to generate the masking program of SC65D02C40, which will reduce the cost of mass production and improve the production efficiency.

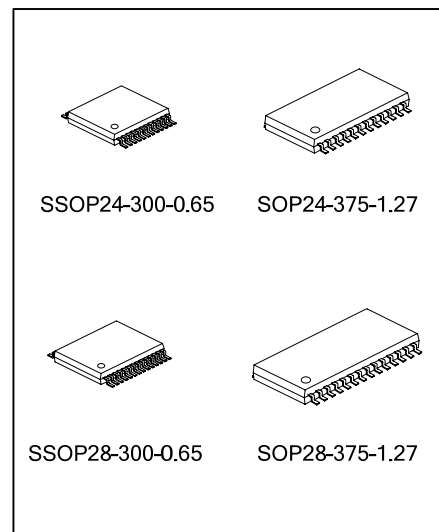

FEATURES

- * Use 8-bit MCU core SC65X.
- * Built-in 8K-byte ROM and 32K-byte OTP memory.
- * Integrate code transmitting circuit, the carrier frequency and duty can be set flexibly, provide 32-byte code transmitting buffer.
- * Maximum 20 pins for key function, support 96 keys.
- * Use CMOS technology, operating voltage is 1.8V ~ 3.6V, quiescent current is less than 1 μ A.
- * Together with good application software, development efficiency is high.

APPLICATIONS

- * Preset universal remote control.

ORDERING INFORMATION

Part No.	General purpose I/O ports	Package	Marking
SC65D02P40	16	SSOP-24-300-0.65	SC65D02P40
SC65D02P40A	16	SOP-24-375-1.27	SC65D02P40A
SC65D02P40B	20	SOP-28-375-1.27	SC65D02P40B
SC65D02P40C	20	SSOP-28-300-0.65	SC65D02P40C

BLOCK DIAGRAM

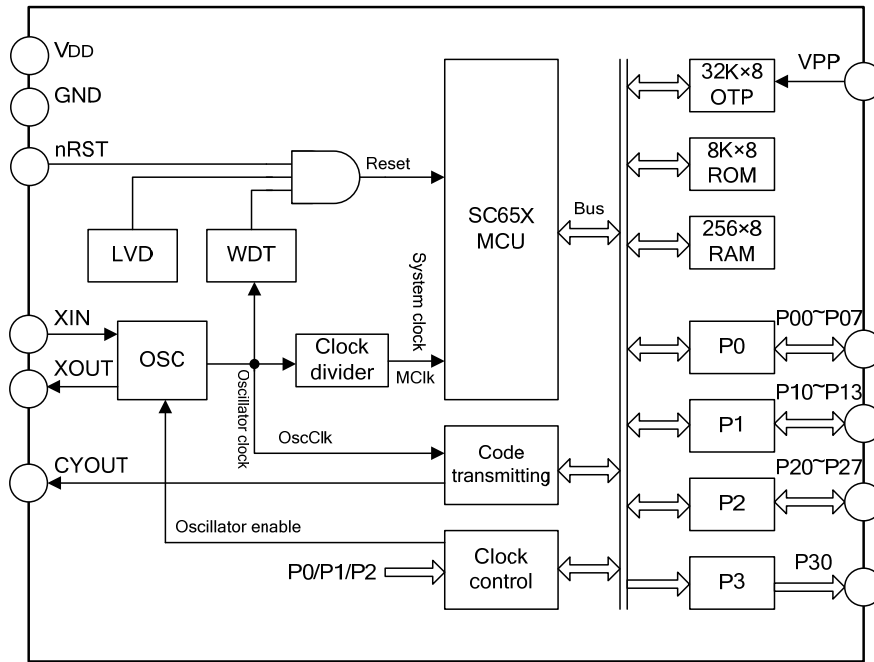

ABSOLUTE MAXIMUM RATINGS

Characteristics	Symbol	Range	Unit
Power Supply	VDD	-0.3 ~ +5.0	V
Input Voltage	VIN	-0.3 ~ VDD+0.3	V
Storage Temperature	Tstg	-40 ~ +125	°C
Operating Temperature	Topr	-20 ~ +70	°C

ELECTRICAL CHARACTERISTICS(unless otherwise specified, VDD=3v, Tamb=25°C)

Characteristics	Symbol	Test condition	Min.	Typ.	Max.	Unit
Operating Voltage	VDD	--	1.8	--	3.6	V
Operating Current	IDD	Code transmitting with no load	--	4.5	5.0	mA
Quiescent Current	IDS	Oscillator off	--	0.1	1	μA
Operating Clock	Fosc	--	2	4	6	MHz
High Level Input Voltage	VIH	--	0.7VDD	--	VDD	V
Low Level Input Voltage	VIL	--	0	--	0.3VDD	V
High Level Output Voltage	VOH	No load	0.9VDD	--	--	V

Characteristics	Symbol	Test condition	Min.	Typ.	Max.	Unit	
Low Level Output Voltage	VOL	No load	--	--	0.1VDD	V	
High Level Current On Output Pin	IOH	VOH=2.7V	P0/P1/P2	4.4	4.5	4.6	mA
			P30	9.8	12	12.3	mA
			CYOUT	9.8	10	10.2	mA
Low Level Current On Output Pin	IOL	VOL=0.3V	P0/P1/P2	9.8	10	10.2	mA
			P30	9.8	12	12.3	mA
			CYOUT	9.8	10	10.2	mA
Port Pull-Up Resistor	Rpu	--	2.0	2.2	2.3	MΩ	

PIN CONFIGURATION

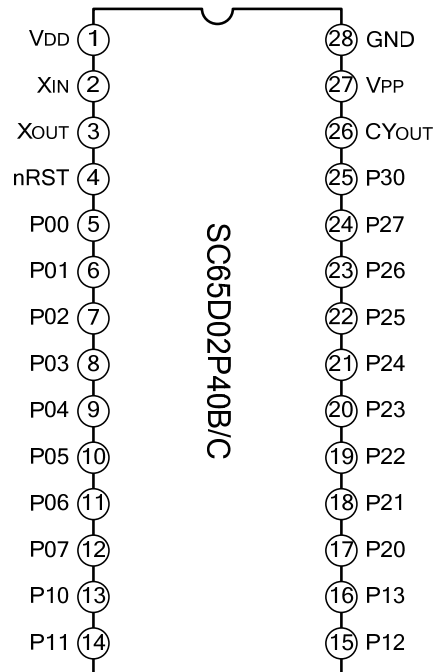
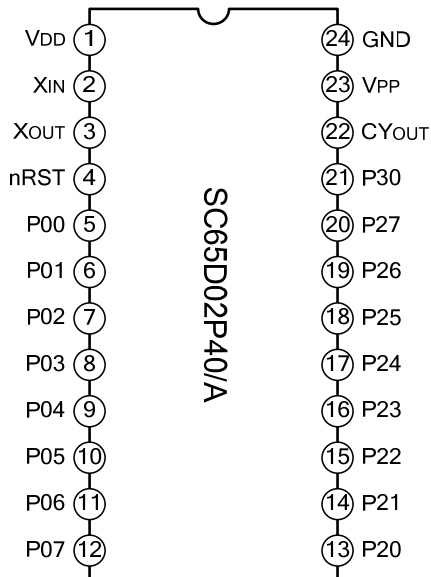

PIN DESCRIPTION
SC65D02P40/A

Pin No.	Pin Name	I/O	Function description
1	VDD	--	Power supply
24	GND	--	Ground
2	XIN	I	External oscillator input pin.
3	XOUT	O	External oscillator output pin (connect driver resistor in series between XOUT and oscillator)
4	nRST	I	External reset pin (internal pull-up resistor, low active)
5~12	P00~P07	I/O	I/O pin usually used for keyboard input
13~20	P20~P27	I/O	I/O pin usually used for keyboard output
21	P30	O	Output pin usually used for driving LED lamp directly.
22	CYOUT	O	Infrared signal control output pin.
23	VPP	--	OTP program voltage input (in program mode, connects to 6.5V voltage, in non-program mode, connects to VDD)

SC65D02P40B/C

Pin No.	Pin Name	I/O	Function description
1	VDD	--	Power supply
28	GND	--	Ground
2	XIN	I	External oscillator input pin.
3	XOUT	O	External oscillator output pin (connect driver resistor in series between XOUT and oscillator)
4	nRST	I	External reset pin (internal pull-up resistor, low active)
5~12	P00~P07	I/O	I/O pin usually used for keyboard input
13~16	P10~P13	I/O	I/O pin usually used for keyboard output
17~24	P20~P27	I/O	I/O pin usually used for keyboard output
25	P30	O	Output pin usually used for driving LED lamp directly.
26	CYOUT	O	Infrared signal control output pin.
27	VPP	--	OTP program voltage input (in program mode, connects to 6.5V voltage, in non-program mode, connects to VDD)

FUNCTION DESCRIPTION

1. Address space assignment

SC65D02P40 distributes program and data space in uniform addressing method, shown in figure 1.

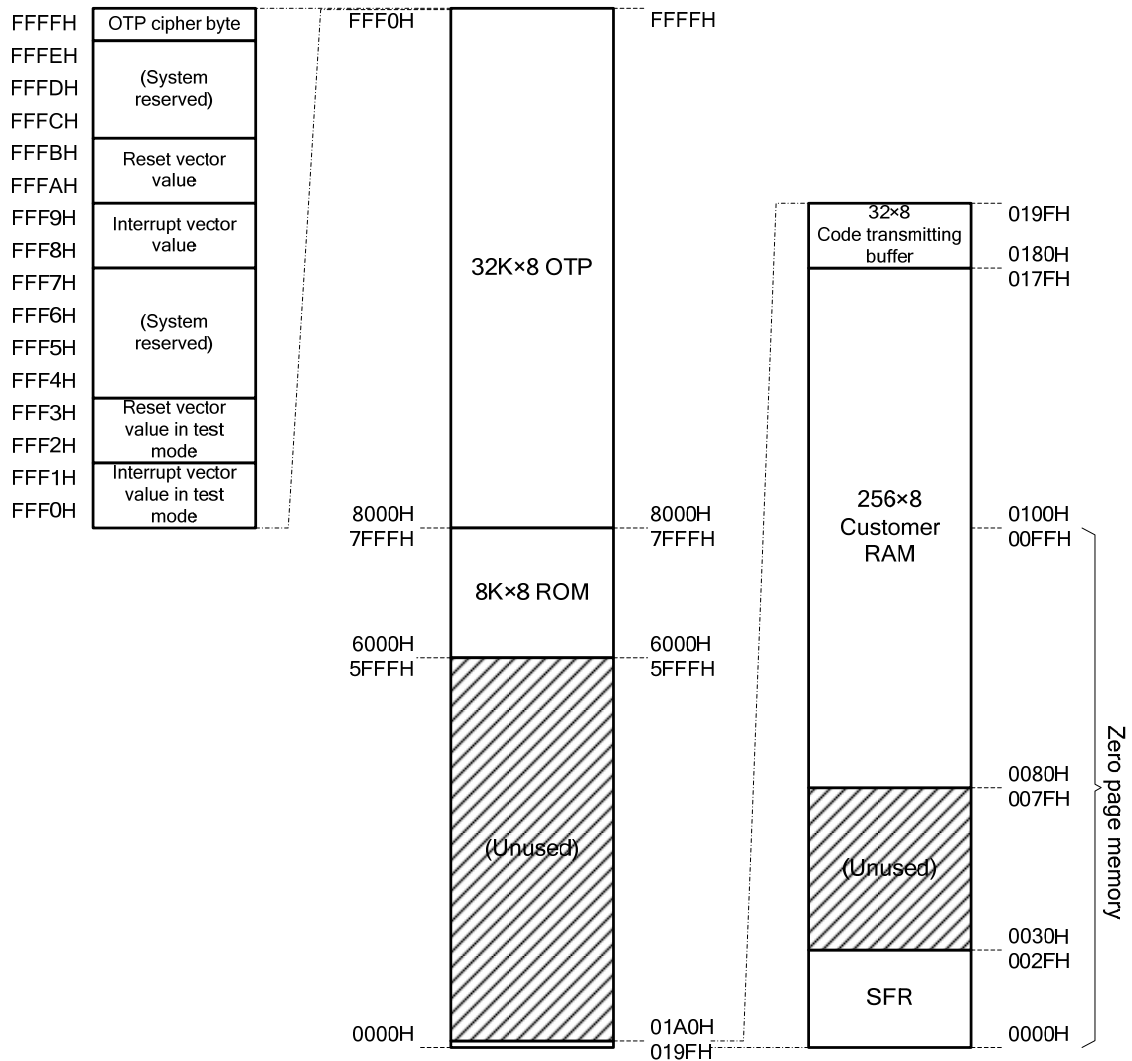

Figure 1 – Address assignment

2. Oscillator circuit

SC65D02P40 provides a high-gain RP-amplifier whose input is XIN and output is XOUT. By connecting a quartz crystal and two capacitors between XIN and XOUT, a stable self oscillator can be composed, shown in figure 2. The oscillation waveform generated by the oscillator circuit generates the oscillator clock after it is reshaped by the inverter. The oscillator clock provides the clock signal for WDT and code transmitting block, at the same time as the SC65X MCU system clock after dividing frequency by 4.

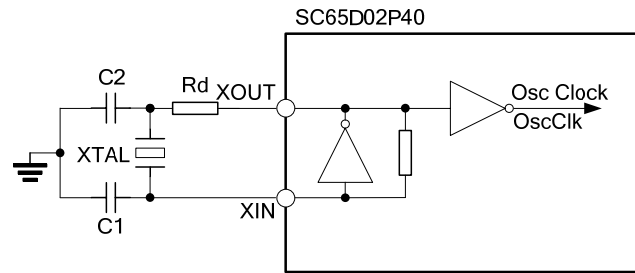

Figure 2 – Oscillator circuit

Where:

- ✧ Rd is drive resistor, the value is 100Ω~ 300Ω.
- ✧ C1 and C2 are load capacitors with same value, the range is : 10pF ~ 30pF.
- ✧ XTAL is crystal oscillator, frequency is 2MHz ~ 6MHz.

3. Periphery modules

3.1 WDT/timer

[Description]

As shown in figure 3, in WDT/timer module, the 16-bit timer can also be used as the low 16-bit of 21-bit WDT. The counting clock of WDT/timer can be directly provided by oscillator clock OscClk.

[Structure]

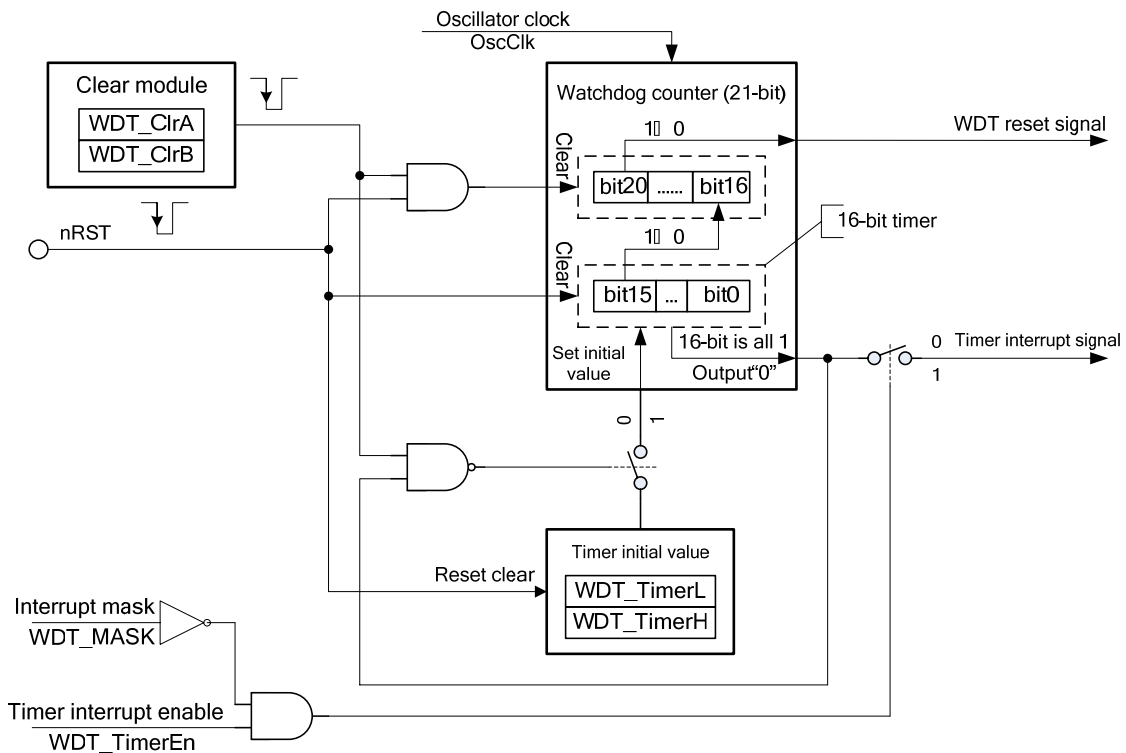

Figure 3 – WDT/timer diagram

[Function description]

When external reset occurs, the initial value of timer(WDT_TimerH, WDT_TimerL)and 21-bit watchdog counter are both cleared.

When use the clear module to reset the watchdog timer, the high 5-bit of the watchdog counter is cleared, the low 16-bit will be loaded from the initial value register of timer again and begin to count.

When the low 16-bit of watchdog counter counts to FFFFH, the timer will overflow if increasing by 1 , then reload the initial value of timer; At this time, if the interrupt mask bit (WDT_MASK)="0" and the timer interrupt enable bit(WDT_TimerEn)="1", it will generate timer interrupt signal, and WDT_FLAG is set.

Add 1 to the counting value of high 5-bit of watchdog timer when bit15 of watchdog counter changes from 1 to 0; the watchdog will generate reset signal if bit20 of watchdog counter changes from 1 to 0.

3.2 I/O ports

[Description]

SC65D02P40 includes three groups of I/O ports: P0, P1 and P2. P0 and P2 are 8-bit parallel ports, while P1 is 4-bit parallel port.

Each I/O port of SC65D02P40 can be set independently as weak pull-up input or push-pull output status. The high level output capacity of the port is much bigger than low level output capacity, so it can identify the dual-key or multi-key pressing at the same time.

[Structure]

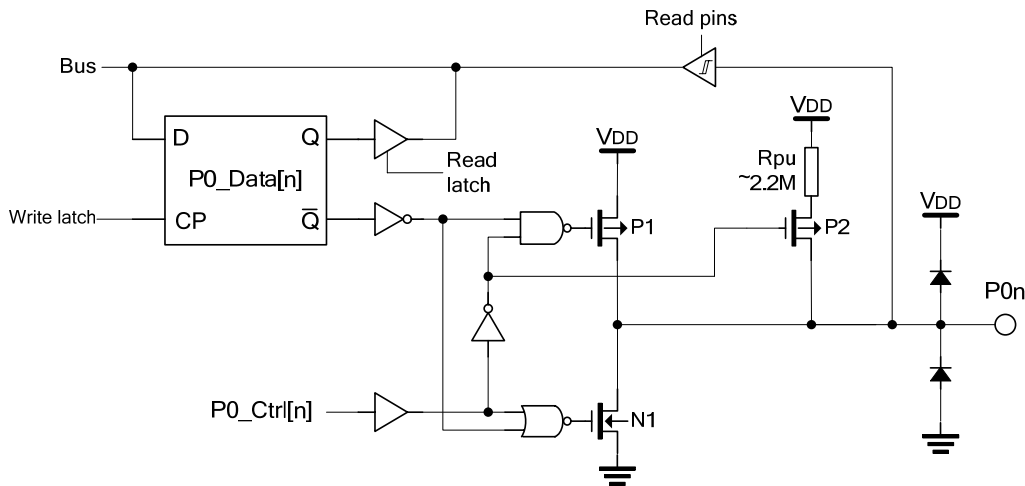

Figure 4 – P0 structure

Note: The structure of P1 and P2 is the same as P0.

[Function description]

As shown in figure 4, we take P0 for example to introduce the I/O port function. The function of P1 and P2 is the same with that of P0.

When P0_Ctrl[n] is set, PMOS P1 and NMOS N1 are both off, PMOS P2 is on, pull-up resistor Rpu is active, and port P0n is input mode.

When P0_Ctrl[n] is cleared, PMOS P2 is off, port P0n is output mode. At this time, when P0_Data[0] is set, PMOS P1 is on, NMOS N1 is off, and port P0n outputs high level; when P0_Data[0] is cleared, PMOS P1 is off, NMOS N1 is on, and port P0n outputs low level.

3.3 P3 port

[Description]

P3 of SC65D02P40 has only one bit which is only as output port.

3.4 ROM

[Description]

SC65D02P40 has built-in 8K-byte read-only memory(ROM), and the address range is 6000H ~ 7FFFH. This ROM is masked with code transmitting program which can simplify the main program development of the customer circuit and self-test program, etc. Of course, the customer may not use the program in ROM.

3.5 OTP memory

[Description]

The address space of OTP memory is 8000H~FFFFH. OTP memory is mainly used to store the main program and read-only data, where FFF0H~FFFFH is the configuration area including the reset vector and interrupt vector in normal working mode and testing mode as well as the protect byte of the OTP, shown in figure 5:

FFFFH	OTP protect byte
FFFEH	(System reserved)
FFFDH	
FFFCH	
FFFBH	Reset vector value
FFFAH	
FFF9H	Interrupt vector value
FFF8H	
FFF7H	(System reserved)
FFF6H	
FFF5H	
FFF4H	
FFF3H	Reset vector value in test mode
FFF2H	
FFF1H	Interrupt vector value in test mode
FFF0H	

Figure 5 – OTP configuration area

The reset vector value is the initial value of PC after the circuit is reset, that is the entry address of the main program, where, the high byte is stored in FFFBH, and low byte is stored in FFFAH. For example: FFFAH stores 40H, FFFBH stores 80H, then after the circuit is reset, then PC points to 8040H.

The interrupt vector value is the initial value of PC after MCU responses to the interrupt, which is the entry address of the interrupt service routine, where, the high byte is stored in FFF9H, and low byte is stored in FFF8H. For example: FFF8H stores 00H, FFF9H stores 80H, then the interrupt entry address is 8000H.

The reset vector value and the interrupt vector value in test mode are useful in production test, and the customer should set FFF0H with 00H, FFF1H with 60H, FFF2H with 04H, FFF3H with 60H to make sure the program down load is correct, for example, the customer should add the following code in proper position:

```

ORG   FFF0H
DW    6000H
DW    6004H
    
```

The default value of OTP protect byte is FFH, now the content of OTP memory can be read by OTP programmer or emulator provided by Silan. If you set OTP cipher byte as 00H, then you cannot read this OTP memory in any method, which can protect the customer's software copyright.

3.6 Code transmitting module

[Description]

This module is used to generate the high and low level sequence for Infrared diode control. It is comprised of carrier generating circuit and 32-byte code transmitting buffer which will realize the exact code transmitting.

[Structure]

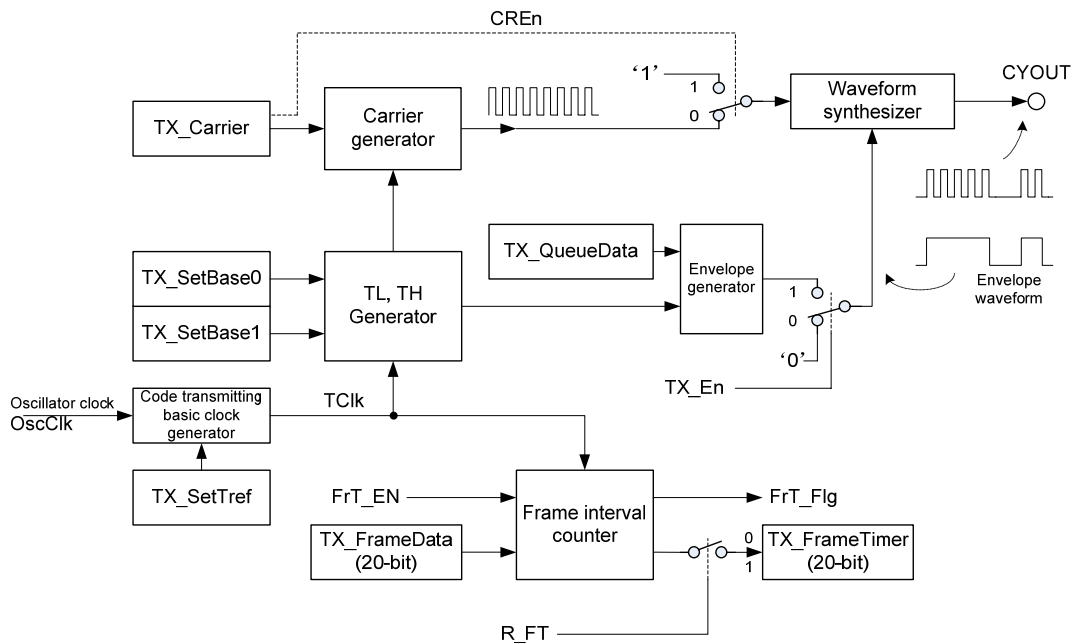

Figure 6 – Code transmitting diagram

[Function description]

The code transmitting of SC65D02P40 defines a universal waveform (figure 7), which should be complied with when transmitting code.

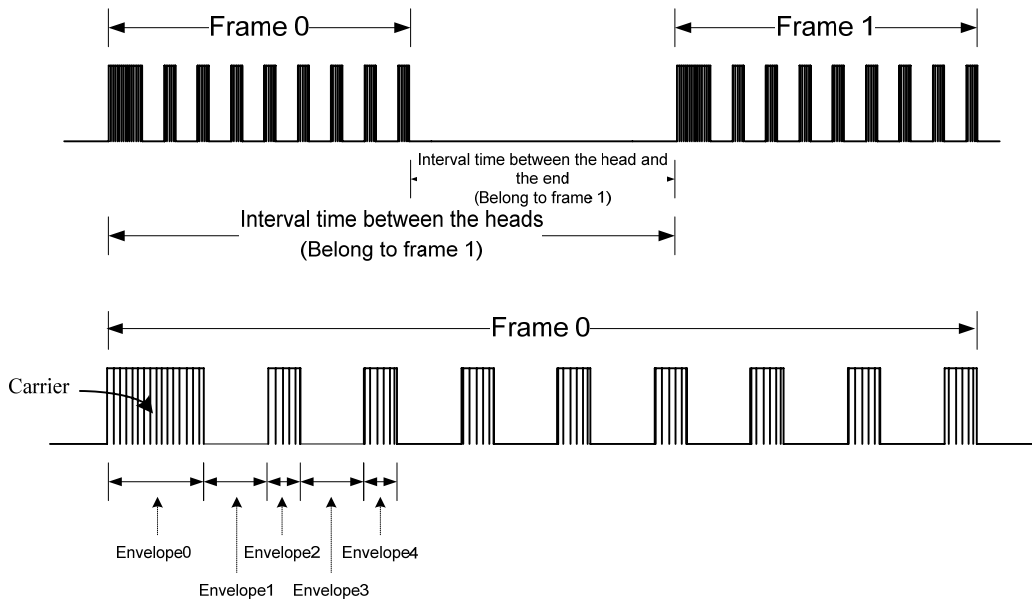

Figure 7 – Code transmitting format

The oscillator clock $OscClk$ generates $TClk$ (the cycle is T) via the code transmitting basic clock. The counting clock of the carrier generator is from the system clock $TClk$, as shown in figure 8. Where, the high level and low level time of the carrier is decided by the customer set $TX_Carrier$, and the unit is T .

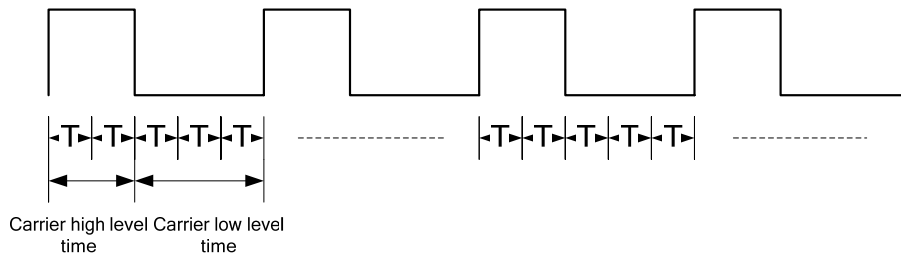

Figure 8 – Carrier generation theory

$TClk$ generates high and low level basic unit time TH and TL via basic 0/1 generator. TH and TL are decided by setting $TX_SetBase1$ and $TX_SetBase0$, and unit is T . TH is the basic unit time of high level time, and TL is the basic unit time of low level time.

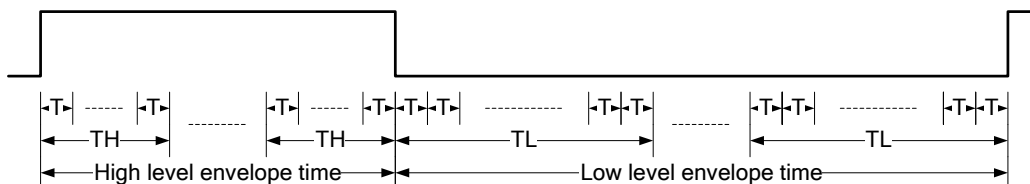

Figure 9 – Code transmitting theory

TYPICAL APPLICATION CIRCUIT

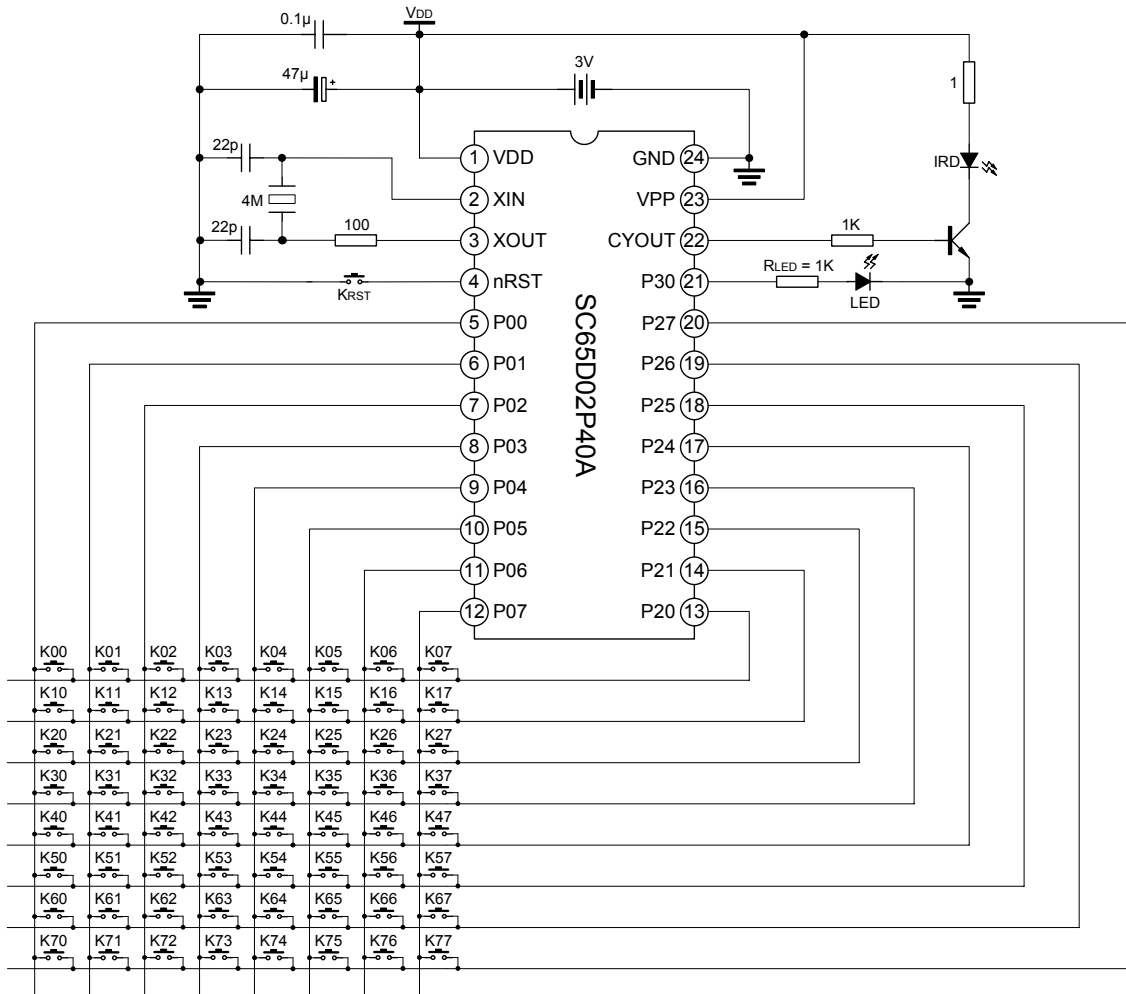

Figure 11(a) – Typical application circuit (a)

TYPICAL APPLICATION CIRCUIT

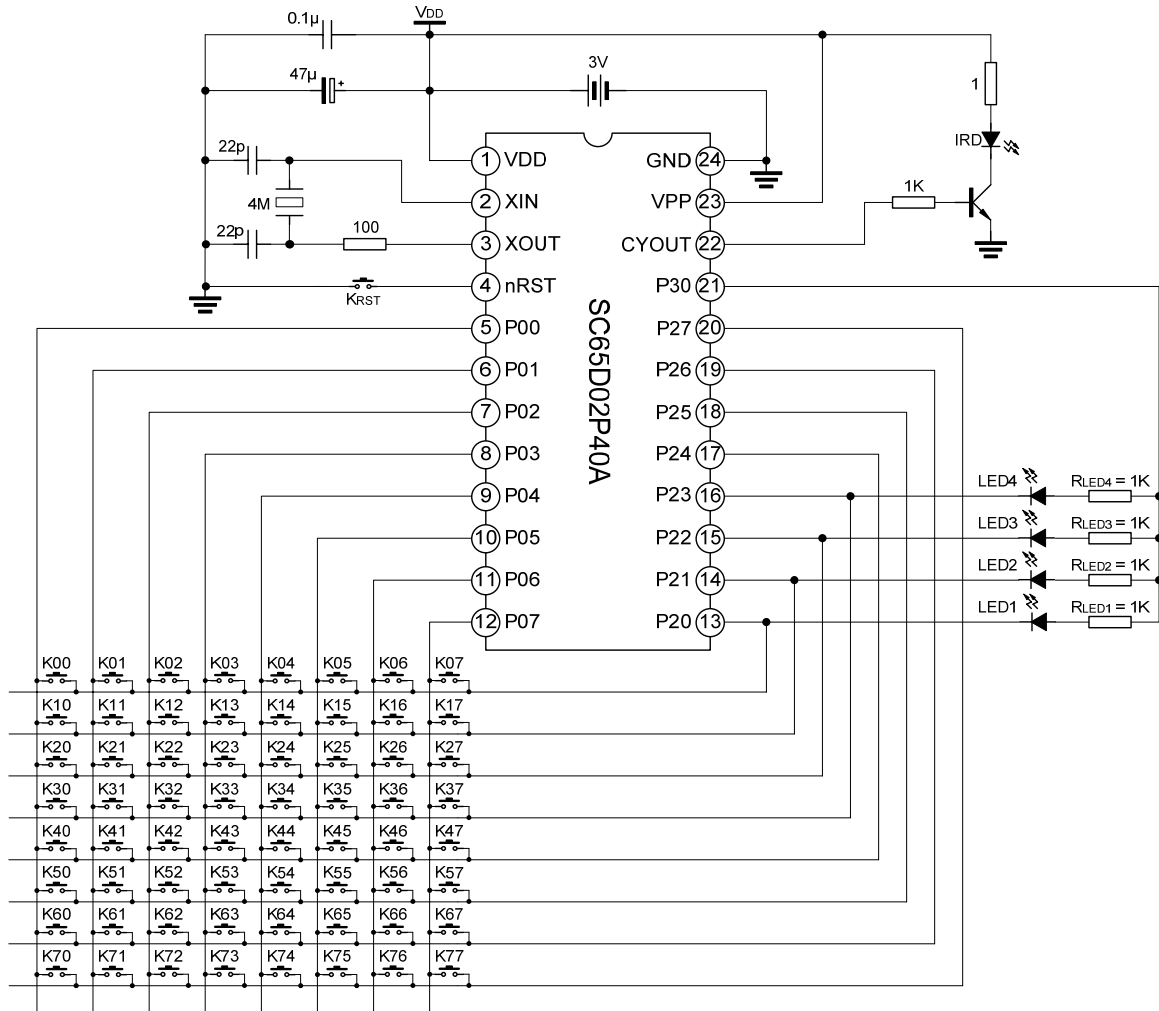

Figure11(c) - Typical application circuit (c)

Note:

- ◇ The design precondition of above three typical application circuits is: if the circuit structure is not changed, the SC65D02C40 can directly take the place of SC65D02P40;
- ◇ Typical application circuit (a) is generally used in the situation with one LED lamp;
- ◇ Typical application circuit (b) is generally used in the situation with many LED lamps, if no need to light all the LEDs, you can use the typical application circuit (c) to save the cost.

PACKAGE OUTLINE

SOP-24-375-1.27

Unit: mm

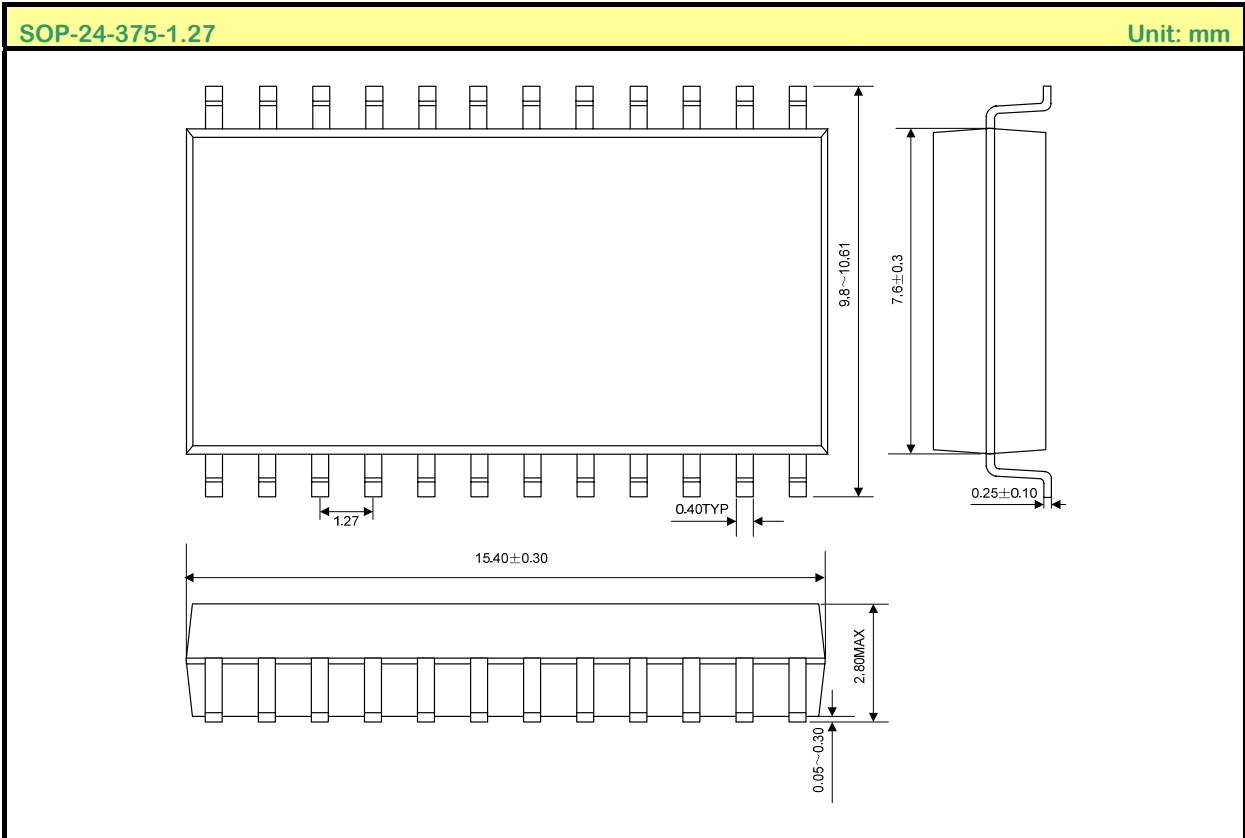

SOP-28-375-1.27

Unit: mm

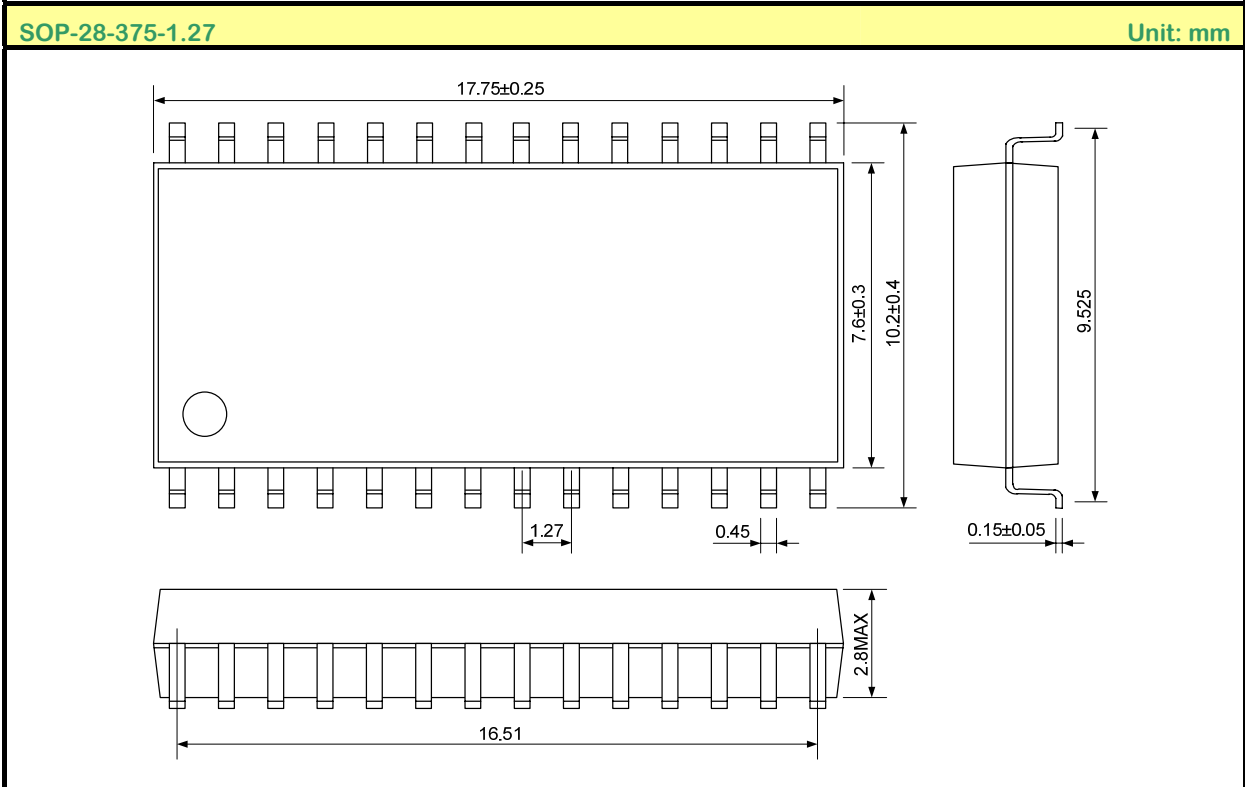

PACKAGE OUTLINE

SSOP-24-300-0.65

Unit: mm

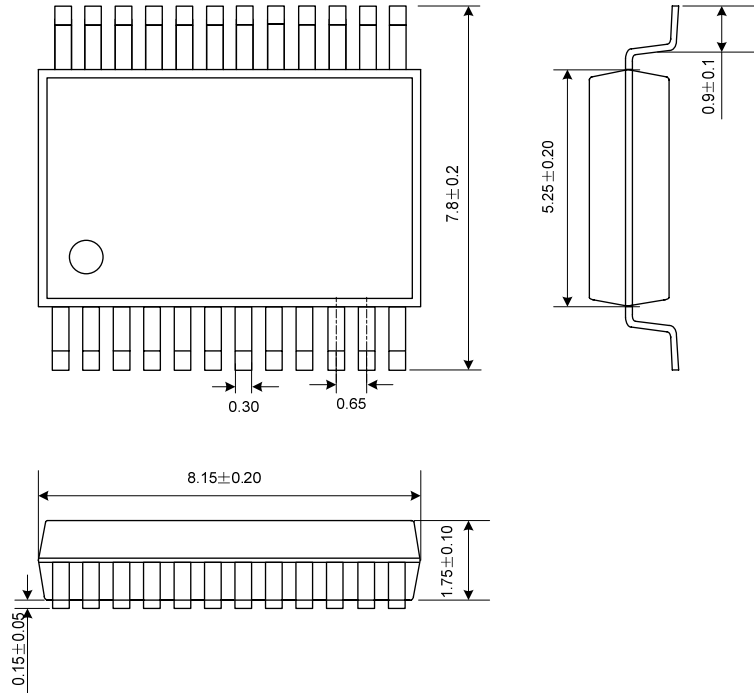

SSOP-28-300-0.65

Unit: mm

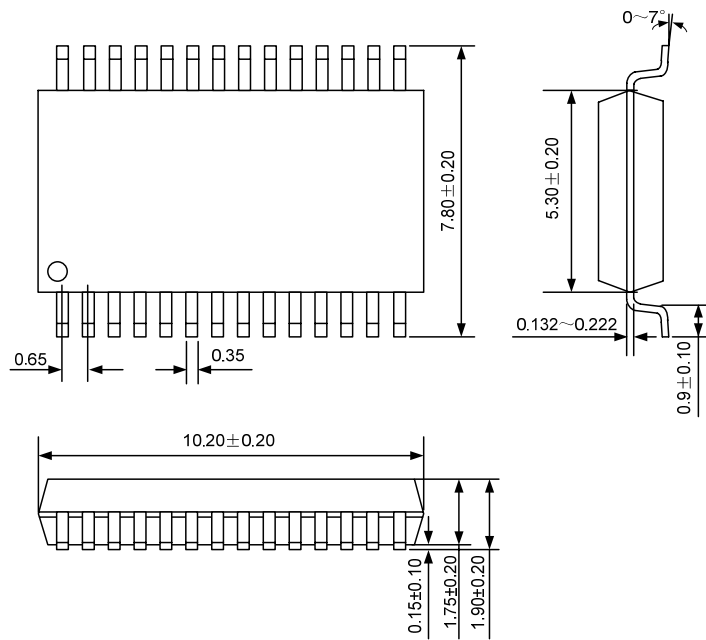



MOS DEVICES OPERATE NOTES:

Electrostatic charges may exist in many things. Please take following preventive measures to prevent effectively the MOS electric circuit as a result of the damage which is caused by discharge:

- The operator must put on wrist strap which should be earthed to against electrostatic.
- Equipment cases should be earthed.
- All tools used during assembly, including soldering tools and solder baths, must be earthed.
- MOS devices should be packed in antistatic/conductive containers for transportation.

Note: Silan reserves the right to make changes without notice in this specification for the improvement of the design and performance.
Silan will supply the best possible product for customers.