

MB40776H/40776

1 CHANNEL 6-BIT D/A CONVERTER

1 CHANNEL 6-BIT D/A CONVERTER

MB40776H (60MSPS)

MB40776 (20MSPS)

The Fujitsu MB40776H and MB40776 are a 6-bit low power ultra-high speed video D/A converter fabricated with Fujitsu Advanced Bipolar Technology. The MB40776H and MB40776 can convert 6-bit digital signals into analog signals at a rate of DC to 60 megasamples/sec (MSPS) for MB40776H and 20MSPS for MB40776. Because of such high speed operation, the both of them are suitable for applications such as digital color TV, video processing with computer, radar signal processing.

- Resolution : 6-bits
- Linearity : $\pm 0.8\%$
- Maximum Conversion Rate : 60MSPS min. for MB40776H
20MSPS min. for MB40776
- Analog Output Voltage range : V_{CC} to $V_{CC} - 1[V]$
- Digital I/O level : TTL Compatible
- Single Power Supply : +5V
- Power Dissipation : 220mW typ.
- Package Plastic DIP Package : (Suffix: -P)
- Package Plastic FPT Package : (Suffix: -PF)

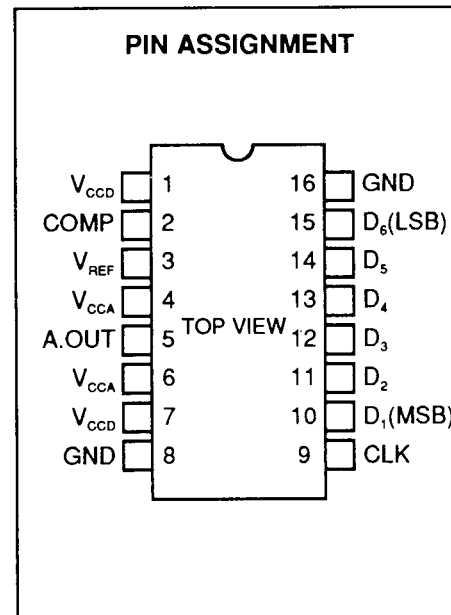
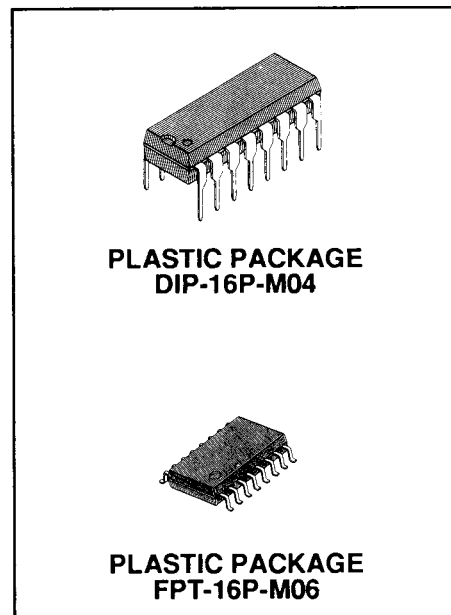

ABSOLUTE MAXIMUM RATINGS (See NOTE)

Rating	Symbol	Value	Unit
Power Supply Voltage	V_{CCA} V_{CCD}	-0.5 to +7.0	V
Digital Input Voltage	V_{IND}	-0.5 to +7.0	V
Analog Reference Voltage	V_{REF}	3.70 to $V_{CC} + 0.5$	V
Storage Temperature	T_{STG}	-55 to +125	$^{\circ}C$

NOTE: Permanent device damage may occur if the above **Absolute Maximum Ratings** are exceeded. Functional operation should be restricted to the conditions as detailed in the operational sections of this data sheet. Exposure to absolute maximum rating conditions for extended periods may affect device reliability.

This device contains circuitry to protect the inputs against damage due to high static voltages or electric fields. However, it is advised that normal precautions be taken to avoid application of any voltage higher than maximum rated voltages to this high impedance circuit.

MB40776H
MB40776

Fig. 1 - BLOCK DIAGRAM

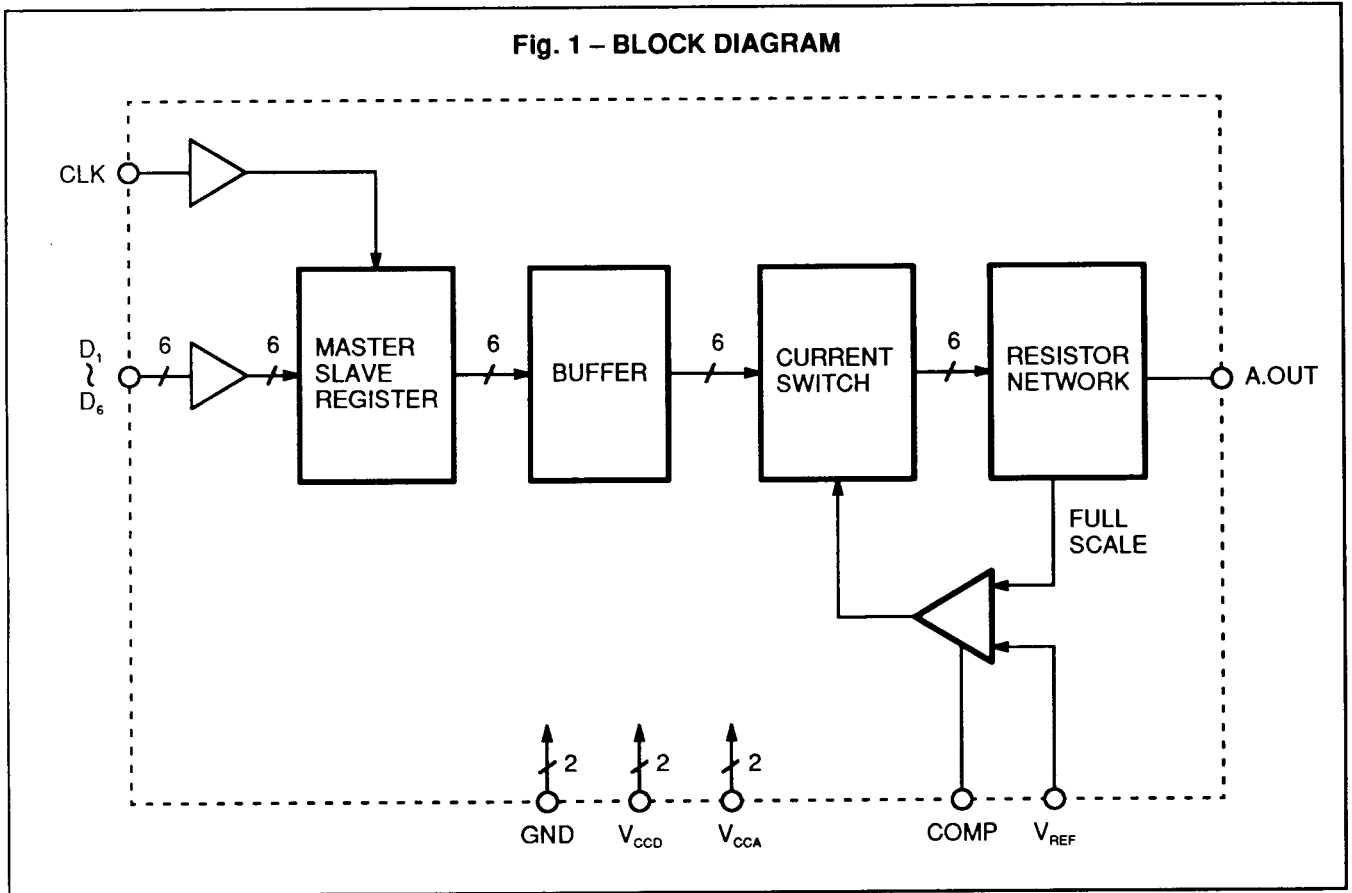

RECOMMENDED OPERATING CONDITIONS

Parameter	Symbol	Value			Unit
		Min	Typ	Max	
Power Supply Voltage	V_{CCA} V_{CCD}	4.75	5.00	5.25	V
Analog Reference Voltage*1	V_{REF}	3.70	4.00	4.30	V
Clock Pulse Width at High level	MB40776H	8.3			ns
	MB40776	25			
Clock Pulse Width at Low level	MB40776H	8.3			ns
	MB40776	25			
Data Setup Time	MB40776H	10.0			ns
	MB40776	12.5			
Data Hold Time	MB40776H	4.0			ns
	MB40776	12.5			
Operating Temperature	T_A	0		70	°C
Phase Compensation Capacitance*2	C_{COMP}	1			μF

NOTE: *1 : $V_{CC} - V_{REF} \leq 1.2V$

*2 : The capacitance should be connected between COMP and GND.

ELECTRICAL CHARACTERISTICS

ANALOG DC CHARACTERISTICS

(V_{CC}=4.75 to 5.25V, T_A=0 to 70°C)

Parameter	Symbol	Condition	Value			Unit
			Min	Typ	Max	
Resolution					6	bits
Linearity Error	LE	DC			±0.8	%
Full-Scale Analog Output Voltage	V _{OF5}	V _{CC} =5.000V V _{REF} =3.976V	V _{CCA} -0.015	V _{CCA}	V _{CCA} +0.015	V
Zero-Scale Analog Output Voltage	V _{OZ5}	V _{CC} =5.000V V _{REF} =3.976V	3.932	3.992	4.052	V
Reference Input Current	I _{REF}	V _{REF} =4.00V			10	μA
Output Impedance	Z _{OUT}	T _A =25°C	70	80	90	Ω

DIGITAL DC CHARACTERISTICS

(V_{CC}=4.75 to 5.25V, T_A=0 to 70°C)

Parameter	Symbol	Condition	Value			Unit
			Min	Typ	Max	
High-level Input Voltage	V _{IHD}		2.0			V
Low-level Input Voltage	V _{ILD}				0.8	V
Maximum Input Current	I _{ID}	V _{CC} =5.25V V _{ID} =7.00V		0	100	μA
High-level Input Current	I _{IHD}	V _{CC} =5.25V V _{IHD} =2.70V		0	20	μA
Low-level Input Current	I _{ILD}	V _{CC} =5.25V V _{ILD} =0.40V	-400	-40		μA
Power Supply Current	I _{CC}	V _{REF} =4.05V		43*	65	mA

NOTE: *V_{CC}=5.00V, V_{REF}=4.00V

SWITCHING CHARACTERISTICS

($V_{CC}=4.75$ to $5.25V$, $T_A=0$ to $70^\circ C$)

Parameter	Symbol	Condition	Value			Unit
			Min	Typ	Max	
Maximum Conversion Rate	MB40776H	FS	60			MSPS
	MB40776		20	30		

Fig. 2 – TIMING DIAGRAM

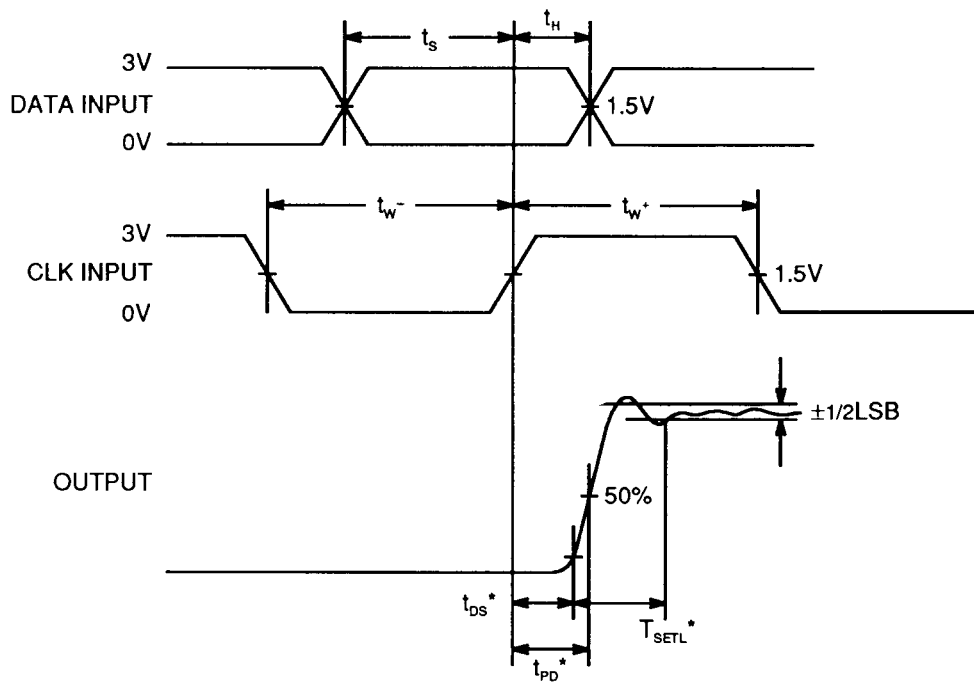

NOTE: *These values are not specified because they depend on application circuit.

Fig. 3 - DIGITAL INPUT EQUIVALENT CIRCUIT

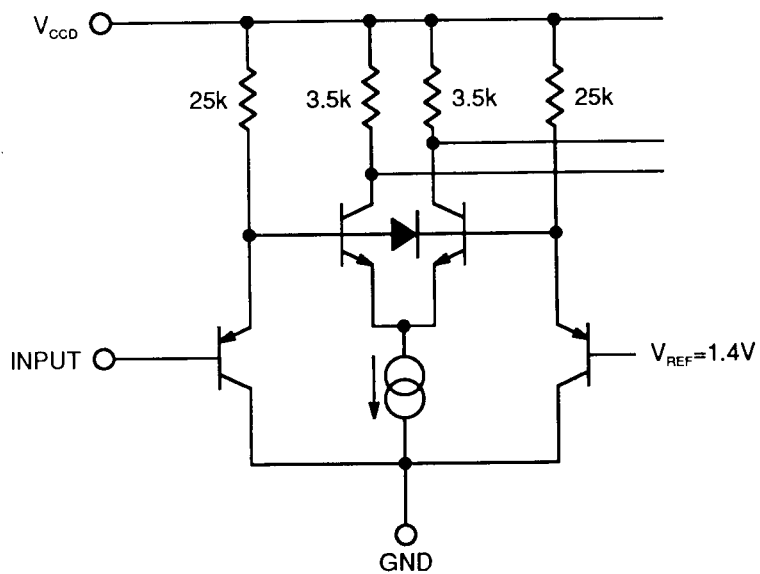
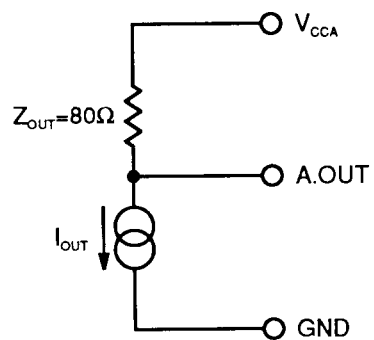

Fig. 4 - OUTPUT EQUIVALENT CIRCUIT



OUTPUT VOLTAGE

($V_{CCA}=5.000V$, $V_{REF}=3.976V$)

Step	Input Code	OUTPUT VOLTAGE (V)
0	000000	3.992
1	000001	4.008
	⋮	⋮
31	011111	4.488
32	100000	4.504
33	100001	4.520
	⋮	⋮
62	111110	4.984
63	111111	5.000

NOTE: 1LSB=16mV

Fig. 5 – IDEAL OUTPUT OPERATION

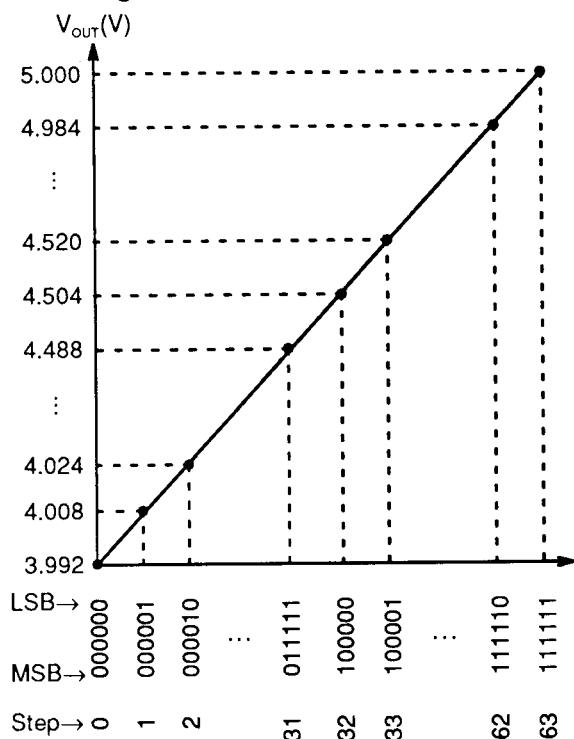
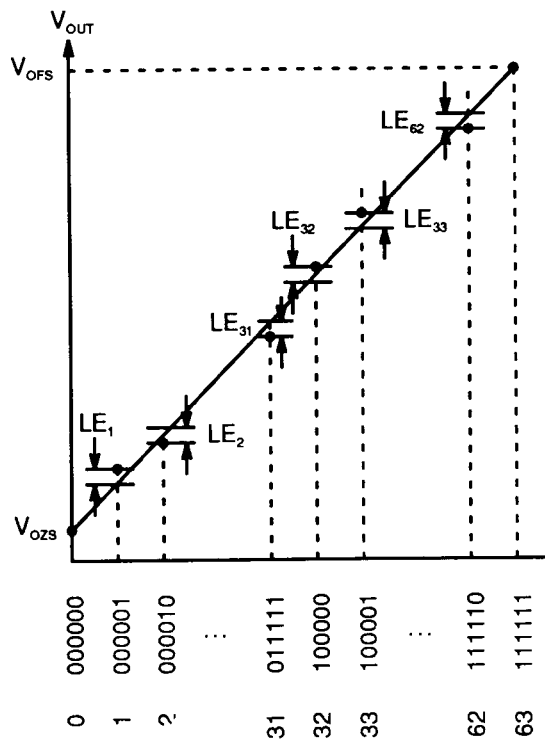

Fig. 6 – PLACTICAL OUTPUT OPERATION



$$\text{Linearity Error} = \frac{|LE_n|_{\max}}{|FS|}$$

TYPICAL CHARACTERISTICS CURVES

Fig. 7 – POWER SUPPLY CURRENT vs. TEMPERATURE

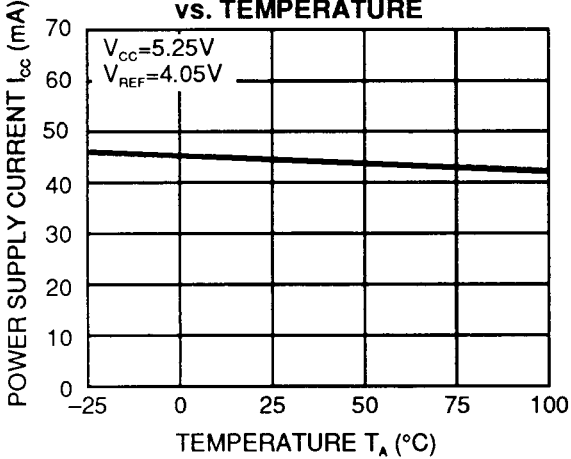

Fig. 8 – LINEARITY ERROR vs. TEMPERATURE

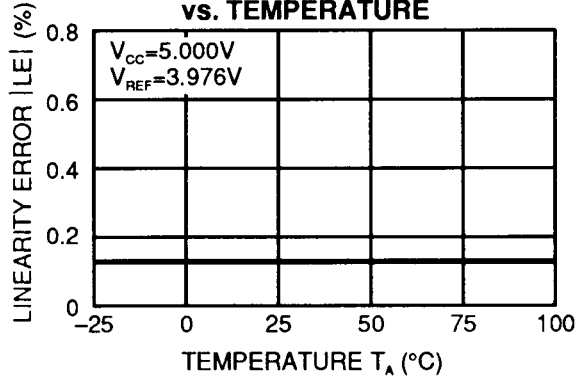

Fig. 9 – OUTPUT IMPEDANCE vs. TEMPERATURE

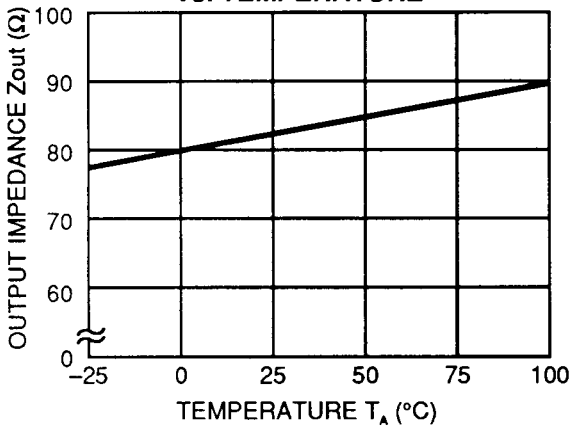

Fig. 10 – ZERO-SCALE ANALOG OUTPUT VOLTAGE vs. TEMPERATURE

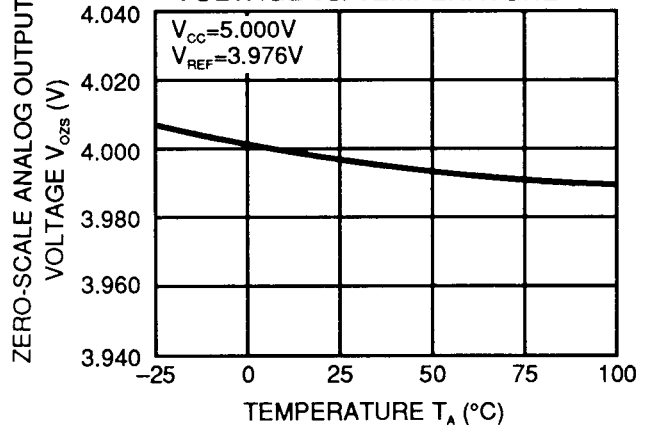

Fig. 11 – FULL-SCALE ANALOG OUTPUT VOLTAGE vs. TEMPERATURE

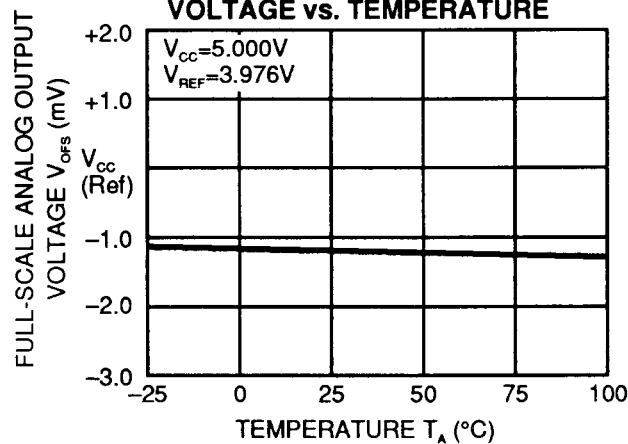

Fig. 12 – DELAY TIME vs. TEMPERATURE

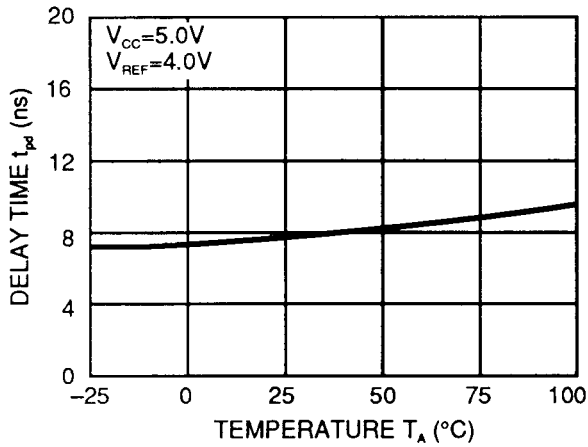

Fig. 13 – DELAY TIME vs. POWER SUPPLY VOLTAGE

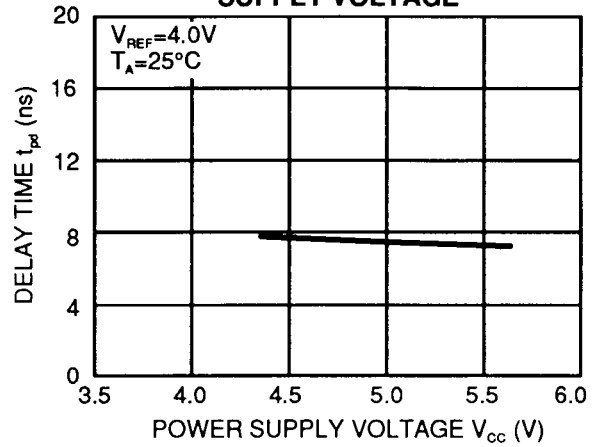

Fig. 14 – CLOCK PULSE WIDTH vs. TEMPERATURE

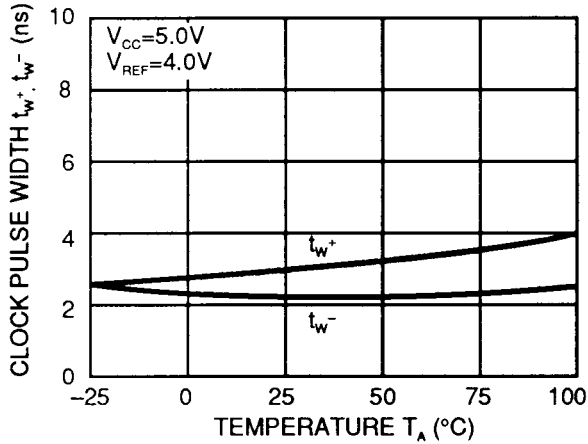

Fig. 15 – CLOCK PULSE WIDTH vs. POWER SUPPLY VOLTAGE

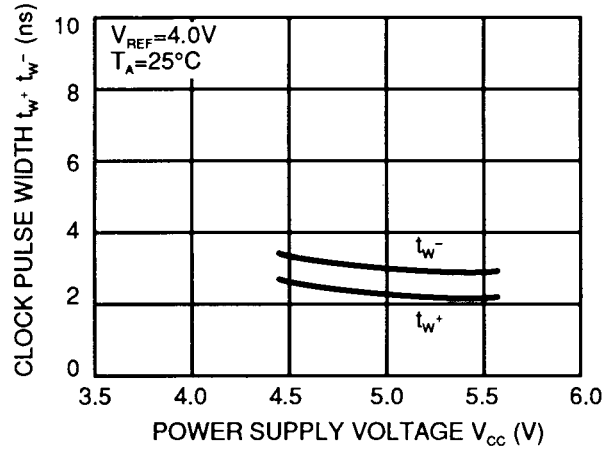
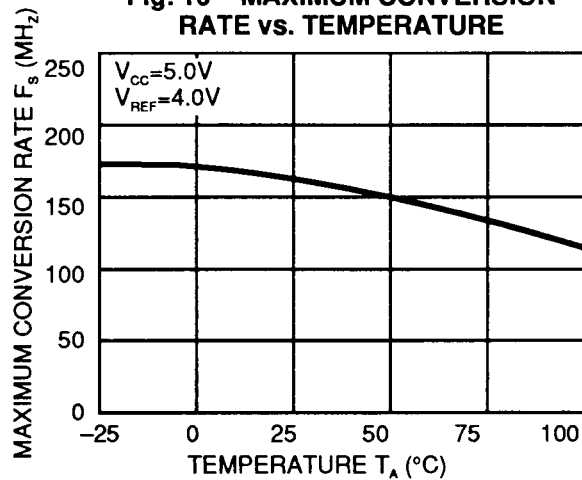

Fig. 16 – MAXIMUM CONVERSION RATE vs. TEMPERATURE



MB40776H
MB40776

PACKAGE DIMENSIONS

16-LEAD PLASTIC DUAL IN-LINE PACKAGE
(CASE No.: DIP-16P-M04)

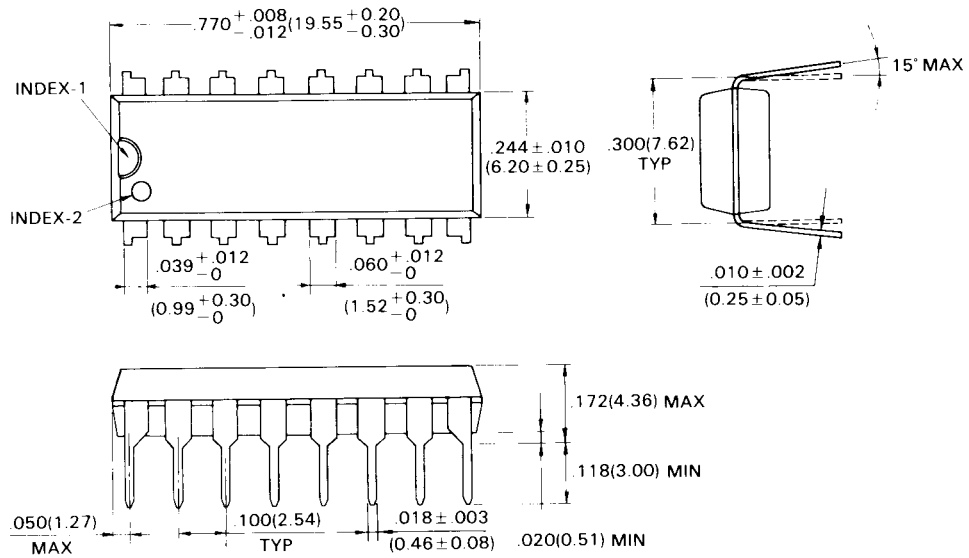

© 1988 FUJITSU LIMITED D16033S-2C

Dimensions in
inches (millimeters)

