

SN5490A, '92A, '93A, SN54LS90, 'LS92, 'LS93 SN7490A, '92A, '93A, SN74LS90, 'LS92, 'LS93

Decade, Divide-By-Twelve And Binary Counters

Each of these monolithic counters contains four master-slave flip-flops and additional gating to provide a divide-by-two counter and a three-stage binary counter for which the count cycle length is divide-by-six for the '92A and 'LS92, and the divide-by-eight for the '93A and 'LS93. All of these counters have a gated zero reset and the '90A and 'LS90 also have gated set-to-nine inputs for use in BCD nine's complement applications.

To use their maximum count length (decade, divide-by-twelve, or four-bit binary) of these counters, the CKB input is connected to the Q_A output. The input count pulses are applied to CKA input and the outputs are as described in the appropriate function table. A symmetrical divide-by-ten count can be obtained from the '90A or 'LS90 counters by connecting the Q_D output to the CKA input and applying the input count to the CKB input which gives a divide-by-ten square wave at output Q_A .

Rochester Electronics Manufactured Components

Rochester branded components are manufactured using either die/wafers purchased from the original suppliers or Rochester wafers recreated from the original IP. All recreations are done with the approval of the OCM.

Parts are tested using original factory test programs or Rochester developed test solutions to guarantee product meets or exceeds the OCM data sheet.

Quality Overview

- ISO-9001
- AS9120 certification
- Qualified Manufacturers List (QML) MIL-PRF-38535
 - Class Q Military
 - Class V Space Level
- Qualified Suppliers List of Distributors (QSLD)
 - Rochester is a critical supplier to DLA and meets all industry and DLA standards.

Rochester Electronics, LLC is committed to supplying products that satisfy customer expectations for quality and are equal to those originally supplied by industry manufacturers.

The original manufacturer's datasheet accompanying this document reflects the performance and specifications of the Rochester manufactured version of this device. Rochester Electronics guarantees the performance of its semiconductor products to the original OEM specifications. 'Typical' values are for reference purposes only. Certain minimum or maximum ratings may be based on product characterization, design, simulation, or sample testing.

**SN5490A, SN5492A, SN5493A, SN54LS90, SN54LS92, SN54LS93,
SN7490A, SN7492A, SN7493A, SN74LS90, SN74LS92, SN74LS93
DECADE, DIVIDE-BY-TWELVE AND BINARY COUNTERS**

MARCH 1974—REVISED MARCH 1988

'90A, 'LS90 . . . Decade Counters

'92A, 'LS92 . . . Divide By-Twelve Counters

'93A, 'LS93 . . . 4-Bit Binary Counters

TYPES	TYPICAL POWER DISSIPATION
'90A	145 mW
'92A, '93A	130 mW
'LS90, 'LS92, 'LS93	45 mW

SN5490A, SN54LS90 . . . J OR W PACKAGE

SN7490A . . . N PACKAGE

SN74LS90 . . . D OR N PACKAGE

(TOP VIEW)

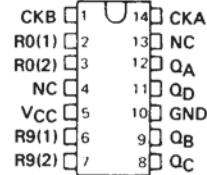

SN5492A, SN54LS92 . . . J OR W PACKAGE

SN7492A . . . N PACKAGE

SN74LS92 . . . D OR N PACKAGE

(TOP VIEW)

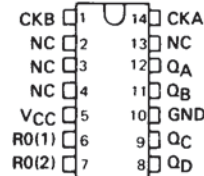

SN5493A, SN54LS93 . . . J OR W PACKAGE

SN7493 . . . N PACKAGE

SN74LS93 . . . D OR N PACKAGE

(TOP VIEW)

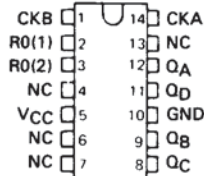

NC—No internal connection

description

Each of these monolithic counters contains four master-slave flip-flops and additional gating to provide a divide-by-two counter and a three-stage binary counter for which the count cycle length is divide-by-five for the '90A and 'LS90, divide-by-six for the '92A and 'LS92, and the divide-by-eight for the '93A and 'LS93.

All of these counters have a gated zero reset and the '90A and 'LS90 also have gated set-to-nine inputs for use in BCD nine's complement applications.

To use their maximum count length (decade, divide-by-twelve, or four-bit binary) of these counters, the CKB input is connected to the QA output. The input count pulses are applied to CKA input and the outputs are as described in the appropriate function table. A symmetrical divide-by-ten count can be obtained from the '90A or 'LS90 counters by connecting the QD output to the CKA input and applying the input count to the CKB input which gives a divide-by-ten square wave at output QA.

2
TTL Devices

PRODUCTION DATA documents contain information current as of publication date. Products conform to specifications per the terms of Texas Instruments standard warranty. Production processing does not necessarily include testing of all parameters.



POST OFFICE BOX 655012 • DALLAS, TEXAS 75265

**SN5490A, '92A, '93A, SN54LS90, 'LS92, 'LS93,
SN7490A, '92A, '93A, SN74LS90, 'LS92, 'LS93
DECADE, DIVIDE-BY-TWELVE, AND BINARY COUNTERS**

logic symbols†

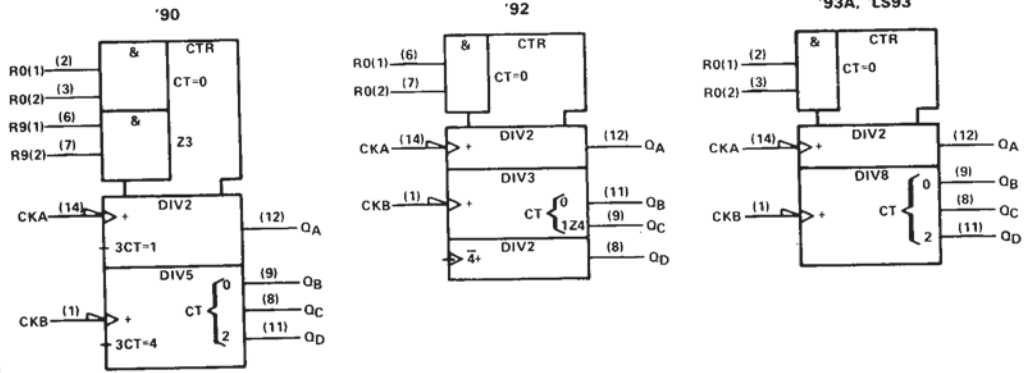

2

TTL Devices

†These symbols are in accordance with ANSI/IEEE Std. 91-1984 and IEC Publication 617-12.

**SN5490A, '92A, '93A, SN54LS90, 'LS92, 'LS93,
SN7490A, '92A, '93A, SN74LS90, 'LS92, 'LS93
DECADE, DIVIDE-BY-TWELVE, AND BINARY COUNTERS**

'90A, 'LS90
BCD COUNT SEQUENCE
(See Note A)

COUNT	OUTPUT			
	Q _D	Q _C	Q _B	Q _A
0	L	L	L	L
1	L	L	L	H
2	L	L	H	L
3	L	L	H	H
4	L	H	L	L
5	L	H	L	H
6	L	H	H	L
7	L	H	H	H
8	H	L	L	L
9	H	L	L	H

'90A, 'LS90
BI-QUINARY (5-2)
(See Note B)

COUNT	OUTPUT			
	Q _A	Q _D	Q _C	Q _B
0	L	L	L	L
1	L	L	L	H
2	L	L	H	L
3	L	L	H	H
4	L	H	L	L
5	H	L	L	L
6	H	L	L	H
7	H	L	H	L
8	H	L	H	H
9	H	H	L	L

'92A, 'LS92
COUNT SEQUENCE
(See Note C)

COUNT	OUTPUT			
	Q _D	Q _C	Q _B	Q _A
0	L	L	L	L
1	L	L	L	H
2	L	L	H	L
3	L	L	H	H
4	L	H	L	L
5	L	H	L	H
6	H	L	L	L
7	H	L	L	H
8	H	L	H	L
9	H	L	H	H
10	H	H	L	L
11	H	H	L	H

'90A, 'LS90
RESET/COUNT FUNCTION TABLE

RESET INPUTS				OUTPUT			
R ₀ (1)	R ₀ (2)	R ₉ (1)	R ₉ (2)	Q _D	Q _C	Q _B	Q _A
H	H	L	X	L	L	L	L
H	H	X	L	L	L	L	L
X	X	H	H	H	L	L	H
X	L	X	L	COUNT			
L	X	L	X	COUNT			
L	X	X	L	COUNT			
X	L	L	X	COUNT			

'92A, 'LS92, '93A, 'LS93
RESET/COUNT FUNCTION TABLE

RESET INPUTS		OUTPUT			
R ₀ (1)	R ₀ (2)	Q _D	Q _C	Q _B	Q _A
H	H	L	L	L	L
L	X	COUNT			
X	L	COUNT			

- NOTES: A. Output Q_A is connected to input CKB for BCD count.
 B. Output Q_D is connected to input CKA for bi-quinary count.
 C. Output Q_A is connected to input CKB.
 D. H = high level, L = low level, X = irrelevant

'93A, 'LS93
COUNT SEQUENCE
(See Note C)

COUNT	OUTPUT			
	Q _D	Q _C	Q _B	Q _A
0	L	L	L	L
1	L	L	L	H
2	L	L	H	L
3	L	L	H	H
4	L	H	L	L
5	L	H	L	H
6	L	H	H	L
7	L	H	H	H
8	H	L	L	L
9	H	L	L	H
10	H	L	H	L
11	H	L	H	H
12	H	H	L	L
13	H	H	L	H
14	H	H	H	L
15	H	H	H	H

2

TTL Devices

**SN5490A, '92A, '93A, SN54LS90, 'LS92, 'LS93,
SN7490A, '92A, '93A, SN74LS90, 'LS92, 'LS93
DECADE, DIVIDE-BY-TWELVE, AND BINARY COUNTERS**

logic diagrams (positive logic)

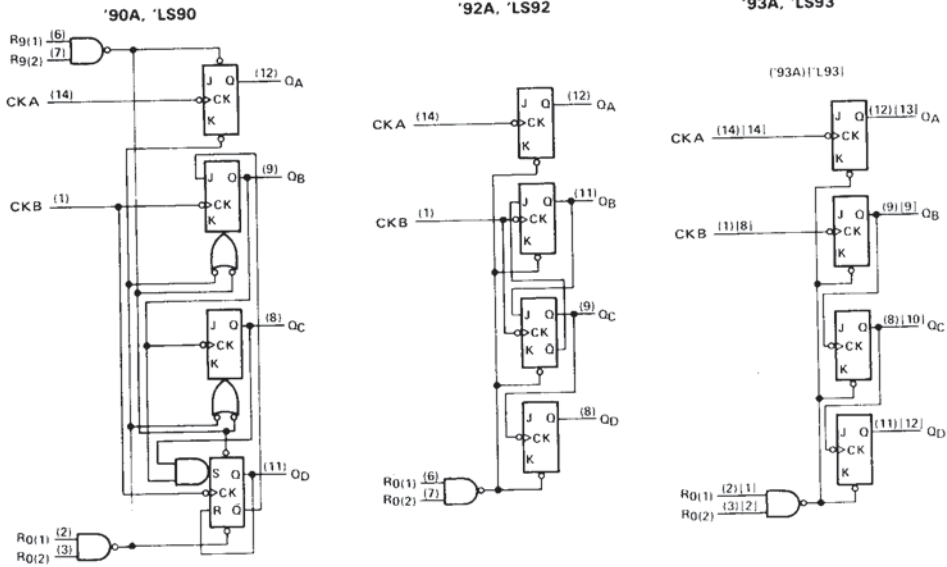

The J and K inputs shown without connection are for reference only and are functionally at a high level.
Pin numbers shown in () are for the 'LS93 and '93A and pin numbers shown in [] are for the 54LS93.

2 TTL Devices

schematics of inputs and outputs

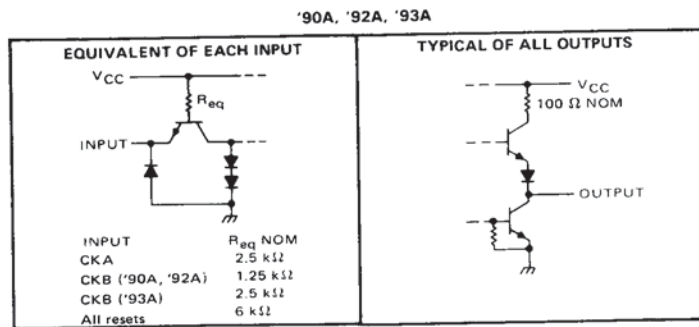

**SN54LS90, 'LS92, 'LS93,
SN74LS90, 'LS92, 'LS93**
DECADE, DIVIDE-BY-TWELVE, AND BINARY COUNTERS

schematics of inputs and outputs (continued)

'LS90, 'LS92, 'LS93

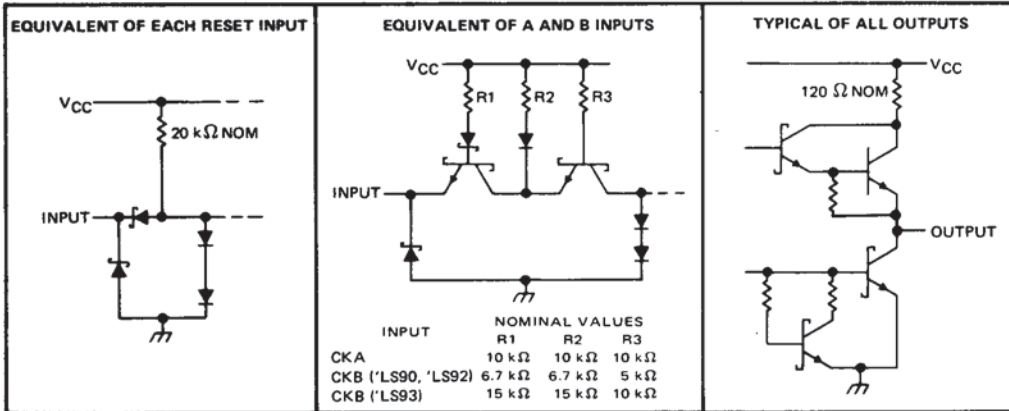

2
TTL Devices

SN5490A, SN5492A, SN5493A, SN7490A, SN7492A, SN7493A DECADE, DIVIDE-BY-TWELVE, AND BINARY COUNTERS

absolute maximum ratings over operating free-air temperature range (unless otherwise noted)

Supply voltage, V_{CC} (see Note 1)	7 V
Input voltage	5.5 V
Interemitter voltage (see Note 2)	5.5 V
Operating free-air temperature range: SN5490A, SN5492A, SN5493A	-55°C to 125°C
SN7490A, SN7492A, SN7493A	0°C to 70°C
Storage temperature range	-65°C to 150°C

NOTES: 1. Voltage values, except interemitter voltage, are with respect to network ground terminal.
2. This is the voltage between two emitters of a multiple emitter transistor. For these circuits, this rating applies between the two R_0 inputs, and for the '90A circuit, it also applies between the two R_0 inputs.

recommended operating conditions

	SN5490A, SN5492A SN5493A			SN7490A, SN7492A SN7493A			UNIT
	MIN	NOM	MAX	MIN	NOM	MAX	
Supply voltage, V_{CC}	4.5	5	5.5	4.75	5	5.25	V
High-level output current, I_{OH}			-800			-800	μ A
Low-level output current, I_{OL}			16			16	mA
Count frequency, f_{COUNT} (see Figure 1)	A input	0	32	0	32		MHz
	B input	0	16	0	16		
Pulse width, t_W	A input	15		15			ns
	B input	30		30			
	Reset inputs	15		15			
Reset inactive-state setup time, t_{SU}		25			25		ns
Operating free-air temperature, T_A		-55	125		0	70	°C

electrical characteristics over recommended operating free-air temperature range (unless otherwise noted)

PARAMETER ^f	TEST CONDITIONS ¹	'90A			'92A			'93A			UNIT
		MIN	TYP ²	MAX	MIN	TYP ²	MAX	MIN	TYP ²	MAX	
V_{IH} High-level input voltage		2			2			2			V
V_{IL} Low-level input voltage				0.8			0.8			0.8	V
V_{IK} Input clamp voltage	$V_{CC} = \text{MIN}, I_I = -12 \text{ mA}$			-1.5			-1.5			-1.5	V
V_{OH} High-level output voltage	$V_{CC} = \text{MIN}, V_{IH} = 2 \text{ V}, V_{IL} = 0.8 \text{ V}, I_{OH} = -800 \mu\text{A}$	2.4	3.4		2.4	3.4		2.4	3.4		V
V_{OL} Low-level output voltage	$V_{CC} = \text{MIN}, V_{IH} = 2 \text{ V}, V_{IL} = 0.8 \text{ V}, I_{OL} = 16 \text{ mA}^{\text{§}}$		0.2	0.4		0.2	0.4		0.2	0.4	V
I_I Input current at maximum input voltage	$V_{CC} = \text{MAX}, V_I = 5.5 \text{ V}$			1			1			1	mA
I_{IH} High-level input current	Any reset			40			40			40	μ A
	CKA	$V_{CC} = \text{MAX}, V_I = 2.4 \text{ V}$		80	$V_{CC} = \text{MAX}, V_I = 2.4 \text{ V}$		80	$V_{CC} = \text{MAX}, V_I = 2.4 \text{ V}$		80	
	CKB	$V_{CC} = \text{MAX}, V_I = 2.4 \text{ V}$		120	$V_{CC} = \text{MAX}, V_I = 2.4 \text{ V}$		120	$V_{CC} = \text{MAX}, V_I = 2.4 \text{ V}$		80	
I_{IL} Low-level input current	Any reset			-1.6			-1.6			-1.6	mA
	CKA	$V_{CC} = \text{MAX}, V_I = 0.4 \text{ V}$		-3.2	$V_{CC} = \text{MAX}, V_I = 0.4 \text{ V}$		-3.2	$V_{CC} = \text{MAX}, V_I = 0.4 \text{ V}$		-3.2	
	CKB	$V_{CC} = \text{MAX}, V_I = 0.4 \text{ V}$		-4.8	$V_{CC} = \text{MAX}, V_I = 0.4 \text{ V}$		-4.8	$V_{CC} = \text{MAX}, V_I = 0.4 \text{ V}$		-3.2	
I_{OS} Short-circuit output current [§]	$V_{CC} = \text{MAX}$	SN54 [¶]	-20	-57	-20	-57	-20	-57	-20	-57	mA
		SN74 [¶]	-18	-57	-18	-57	-18	-57	-18	-57	
I_{CC} Supply current	$V_{CC} = \text{MAX}, \text{ See Note 3}$		29	42		26	39		26	39	mA

¹ For conditions shown as MIN or MAX, use the appropriate value specified under recommended operating conditions.

² All typical values are at $V_{CC} = 5 \text{ V}, T_A = 25 \text{ C}$.

³ Not more than one output should be shorted at a time.

⁴ I_{OH} outputs are tested at $I_{OL} = 16 \text{ mA}$ plus the limit value for I_{IL} for the CKB input. This permits driving the CKB input while maintaining full fan out capability.

NOTE 3: I_{CC} is measured with all outputs open, both R_0 inputs grounded following momentary connection to 4.5 V, and all other inputs grounded.

2

TTL Devices

**SN5490A, SN5492A, SN5493A, SN7490A, SN7492A, SN7493A
DECADE, DIVIDE-BY-TWELVE, AND BINARY COUNTERS**

switching characteristics, $V_{CC} = 5\text{ V}$, $T_A = 25^\circ\text{ C}$

PARAMETER†	FROM (INPUT)	TO (OUTPUT)	TEST CONDITIONS	'90A			'92A			'93A			UNIT
				MIN	TYP	MAX	MIN	TYP	MAX	MIN	TYP	MAX	
f_{max}	CKA	Q_A	$C_L = 15\text{ pF}$, $R_L = 400\ \Omega$, See Figure 1	32	42		32	42		32	42		MHz
	CKB	Q_B		16			16			16			
t_{PLH}	CKA	Q_A		10	16		10	16		10	16		ns
t_{PHL}				12	18		12	18		12	18		
t_{PLH}	CKA	Q_D		32	48		32	48		46	70		ns
t_{PHL}				34	50		34	50		46	70		
t_{PLH}	CKB	Q_B		10	16		10	16		10	16		ns
t_{PHL}				14	21		14	21		14	21		
t_{PLH}	CKB	Q_C		21	32		10	16		21	32		ns
t_{PHL}				23	35		14	21		23	35		
t_{PLH}	CKB	Q_D		21	32		21	32		34	51		ns
t_{PHL}				23	35		23	35		34	51		
t_{PHL}	Set-to-0	Any		26	40		26	40		26	40		ns
t_{PLH}	Set-to-9	Q_A, Q_D		20	30								ns
t_{PHL}		Q_B, Q_C		26	40								

† f_{max} = maximum count frequency
 t_{PLH} = propagation delay time, low-to-high-level output
 t_{PHL} = propagation delay time, high-to-low-level output

2

TTL Devices

**SN54LS90, SN54LS92, SN54LS93,
SN74LS90, SN74LS92, SN74LS93
DECADE, DIVIDE-BY-TWELVE, AND BINARY COUNTERS**

absolute maximum ratings over operating free-air temperature range (unless otherwise noted)

Supply voltage, V_{CC} (see Note 1)	7 V
Input voltage: R inputs	7 V
A and B inputs	5.5 V
Operating free-air temperature range: SN54LS ¹ Circuits	-55°C to 125°C
SN74LS ¹ Circuits	0°C to 70°C
Storage temperature range	-65°C to 150°C

NOTE 1: Voltage values are with respect to network ground terminal.

recommended operating conditions

	SN54LS90 SN54LS92 SN54LS93			SN74LS90 SN74LS92 SN74LS93			UNIT
	MIN	NOM	MAX	MIN	NOM	MAX	
Supply voltage, V_{CC}	4.5	5	5.5	4.75	5	5.25	V
High-level output current, I_{OH}	-400			-400			μ A
Low-level output current, I_{OL}	4			8			mA
Count frequency, f_{count} (see Figure 1)	A input	0	32	0	32		MHz
	B input	0	16	0	16		
Pulse width, t_w	A input	15		15			ns
	B input	30		30			
	Reset inputs	30		30			
Reset inactive-state setup time, t_{su}	25			25			ns
Operating free-air temperature, T_A	-55	125		0	70		°C

electrical characteristics over recommended operating free-air temperature range (unless otherwise noted)

PARAMETER	TEST CONDITIONS [†]	SN54LS90 SN54LS92			SN74LS90 SN74LS92			UNIT	
		MIN	TYP [‡]	MAX	MIN	TYP [‡]	MAX		
V_{IH} High-level input voltage		2			2			V	
V_{IL} Low-level input voltage				0.7			0.8	V	
V_{IK} Input clamp voltage	$V_{CC} = \text{MIN}, I_I = -18 \text{ mA}$			-1.5			-1.5	V	
V_{OH} High-level output voltage	$V_{CC} = \text{MIN}, V_{IH} = 2 \text{ V}, V_{IL} = V_{IL \text{ max}}, I_{OH} = -400 \mu\text{A}$	2.5	3.4		2.7	3.4		V	
V_{OL} Low-level output voltage	$V_{CC} = \text{MIN}, V_{IH} = 2 \text{ V}, V_{IL} = V_{IL \text{ max}}, I_{OL} = 4 \text{ mA}^{\S}, I_{OL} = 8 \text{ mA}^{\parallel}$		0.25	0.4		0.25	0.4	V	
I_I Input current at maximum input voltage	Any reset	$V_{CC} = \text{MAX}, V_I = 7 \text{ V}$			0.1			0.1	mA
	CKA	$V_{CC} = \text{MAX}, V_I = 5.5 \text{ V}$			0.2			0.2	
	CKB	$V_{CC} = \text{MAX}, V_I = 5.5 \text{ V}$			0.4			0.4	
I_{IH} High-level input current	Any reset	$V_{CC} = \text{MAX}, V_I = 2.7 \text{ V}$			20			20	μ A
	CKA	$V_{CC} = \text{MAX}, V_I = 2.7 \text{ V}$			40			40	
	CKB	$V_{CC} = \text{MAX}, V_I = 2.7 \text{ V}$			80			80	
I_{IL} Low-level input current	Any reset	$V_{CC} = \text{MAX}, V_I = 0.4 \text{ V}$			-0.4			-0.4	mA
	CKA	$V_{CC} = \text{MAX}, V_I = 0.4 \text{ V}$			-2.4			-2.4	
	CKB	$V_{CC} = \text{MAX}, V_I = 0.4 \text{ V}$			-3.2			-3.2	
I_{OS} Short-circuit output current [§]	$V_{CC} = \text{MAX}$	-20	-100		-20	-100		mA	
I_{CC} Supply current	$V_{CC} = \text{MAX},$ See Note 3	'LS90		9		15		mA	
		'LS92		9		15			

[†]For conditions shown as MIN or MAX, use the appropriate value specified under recommended operating conditions.

[‡]All typical values are at $V_{CC} = 5 \text{ V}, T_A = 25^\circ\text{C}$.

[§]Not more than one output should be shorted at a time, and duration of the short-circuit should not exceed one second.

[¶] I_{QA} outputs are tested at specified I_{OL} plus the limit value of I_{IL} for the CKB input. This permits driving the CKB input while maintaining full fan-out capability.

NOTE 3: I_{CC} is measured with all outputs open, both R_O inputs grounded following momentary connection to 4.5 V, and all other inputs grounded.

2

TTL Devices

**SN54LS90, SN54LS92, SN54LS93,
SN74LS90, SN74LS92, SN74LS93
DECADE, DIVIDE-BY-TWELVE, AND BINARY COUNTERS**

electrical characteristics over recommended operating free-air temperature range (unless otherwise noted)

PARAMETER	TEST CONDITIONS†	SN54LS93			SN74LS93			UNIT
		MIN	TYP‡	MAX	MIN	TYP‡	MAX	
V _{IH} High-level input voltage		2			2			V
V _{IL} Low-level input voltage				0.7			0.8	V
V _{IK} Input clamp voltage	V _{CC} = MIN, I _I = -18 mA			-1.5			-1.5	V
V _{OH} High-level output voltage	V _{CC} = MIN, V _{IH} = 2 V, V _{IL} = V _{IL} max, I _{OH} = -400 µA	2.5	3.4		2.7	3.4		V
V _{OL} Low-level output voltage	V _{CC} = MIN, V _{IH} = 2 V, V _{IL} = V _{IL} max			I _{OL} = 4 mA¶ I _{OL} = 8 mA¶			0.25 0.4 0.25 0.4 0.35 0.5	V
I _I Input current at maximum input voltage	Any reset	V _{CC} = MAX, V _I = 7 V			0.1			mA
	CKA or CKB	V _{CC} = MAX, V _I = 5.5 V			0.2			
I _{IH} High-level input current	Any reset	V _{CC} = MAX, V _I = 2.7 V			20			µA
	CKA or CKB				40			
I _{IL} Low-level input current	Any reset	V _{CC} = MAX, V _I = 0.4 V			-0.4			mA
	CKA				-2.4			
	CKB				-1.6			
I _{OS} Short-circuit output current‡	V _{CC} = MAX	-20		-100	-20		-100	mA
I _{CC} Supply current	V _{CC} = MAX, See Note 3		9	15		9	15	mA

† For conditions shown as MIN or MAX, use the appropriate value specified under recommended operating conditions.

‡ All typical values are at V_{CC} = 5 V, T_A = 25°C.

§ Not more than one output should be shorted at a time, and duration of the short-circuit should not exceed one second.

¶ Q_A outputs are tested at specified I_{OL} plus the limit value for I_{IL} for the CKB input. This permits driving the CKB input while maintaining full fan-out capability.

NOTE 3: I_{CC} is measured with all outputs open, both R_D inputs grounded following momentary connection to 4.5 V, and all other inputs grounded.

switching characteristics, V_{CC} = 5 V, T_A = 25°C

PARAMETER#	FROM (INPUT)	TO (OUTPUT)	TEST CONDITIONS	'LS90			'LS92			'LS93			UNIT
				MIN	TYP	MAX	MIN	TYP	MAX	MIN	TYP	MAX	
f _{max}	CKA	Q _A	C _L = 15 pF, R _L = 2 kΩ See Figure 1	32	42		32	42		32	42		MHz
	CKB	Q _B		16			16			16			
t _{PLH}	CKA	Q _A		10	16		10	16		10	16		ns
t _{PHL}		Q _B		12	18		12	18		12	18		
t _{PLH}	CKA	Q _D		32	48		32	48		46	70		ns
t _{PHL}		Q _D		34	50		34	50		46	70		
t _{PLH}	CKB	Q _B		10	16		10	16		10	16		ns
t _{PHL}		Q _B		14	21		14	21		14	21		
t _{PLH}	CKB	Q _C		21	32		10	16		21	32		ns
t _{PHL}		Q _C		23	35		14	21		23	35		
t _{PLH}	CKB	Q _D		21	32		21	32		34	51		ns
t _{PHL}		Q _D		23	35		23	35		34	51		
t _{PHL}	Set-to-0	Any		26	40		26	40		26	40		ns
t _{PLH}	Set-to-9	Q _A , Q _D		20	30								ns
t _{PHL}		Q _B , Q _C		26	40								

#f_{max} = maximum count frequency

t_{PLH} = propagation delay time, low-to-high-level output

t_{PHL} = propagation delay time, high-to-low-level output

2
TTL Devices

2 TTL Devices

SN5490A, SN5492A, SN5493A, SN54LS90, SN54LS92, SN54LS93, SN7490A, SN7492A, SN7493A, SN74LS90, SN74LS92, SN74LS93 DECADE, DIVIDE-BY-TWELVE, AND BINARY COUNTERS

PARAMETER MEASUREMENT INFORMATION

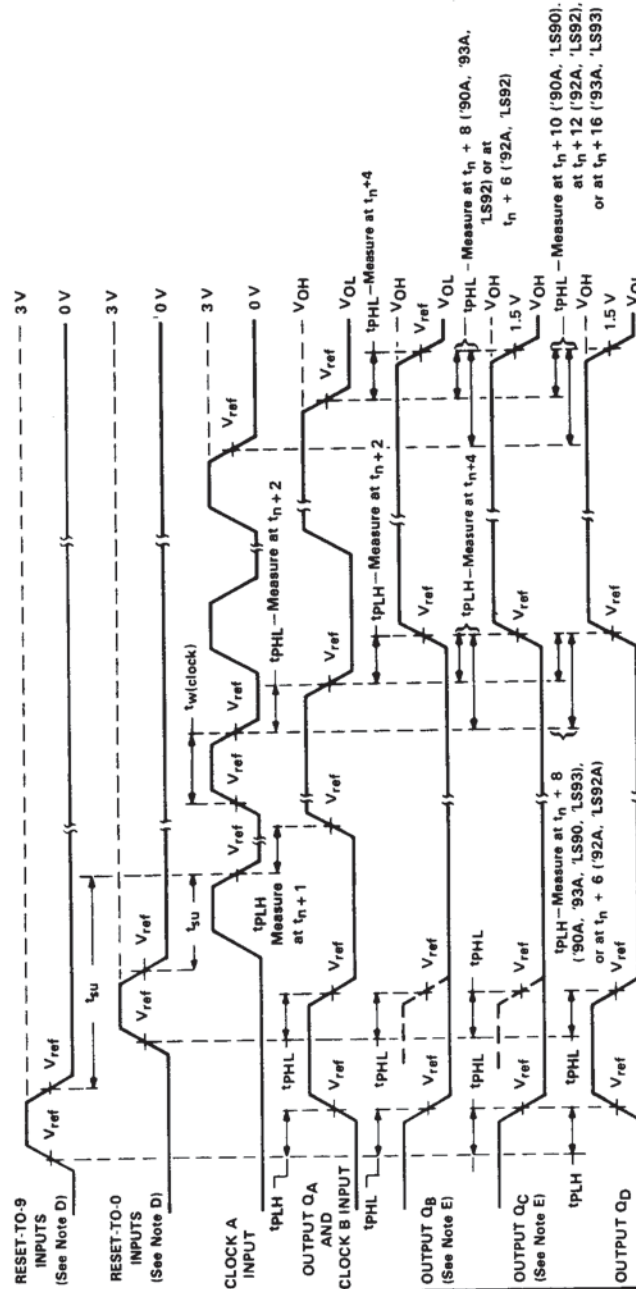

- NOTES: A. Input pulses are supplied by a generator having the following characteristics:
 for '90A, '92A, '93A, $t_r \leq 5$ ns, $t_f \leq 5$ ns, PRR = 1 MHz, duty cycle = 50%, $Z_{out} \approx 50$ ohms;
 for 'LS90, 'LS92, 'LS93, $t_r \leq 15$ ns, $t_f \leq 5$ ns, PRR = 1 MHz, duty cycle = 50%, $Z_{out} \approx 50$ ohms.
- B. C_L includes probe and jig capacitance.
- C. All diodes are 1N3064 or equivalent.
- D. Each reset input is tested separately with the other reset at 4.5 V.
- E. Reference waveforms are shown with dashed lines.
- F. For '90A, '92A, and '93A: $V_{ref} = 1.5$ V. For 'LS90, 'LS92, and 'LS93: $V_{ref} = 1.3$ V.

FIGURE 1A

**SN5490A, SN5492A, SN5493A, SN54LS90, SN54LS92, SN54LS93,
SN7490A, SN7492A, SN7493A, SN74LS90, SN74LS92, SN74LS93
DECADE, DIVIDE-BY-TWELVE, AND BINARY COUNTERS**

PARAMETER MEASUREMENT INFORMATION

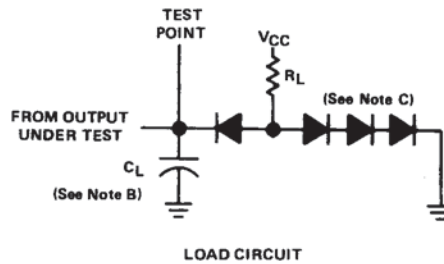

- NOTES: A. Input pulses are supplied by a generator having the following characteristics:
for '90A, '92A, '93A, $t_r \leq 5$ ns, $t_f \leq 5$ ns, PRR = 1 MHz, duty cycle = 50%, $Z_{out} \approx 50$ ohms;
for 'LS90, 'LS92, 'LS93, $t_r \leq 15$ ns, $t_f \leq 5$ ns, PRR = 1 MHz, duty cycle = 50%, $Z_{out} = 50$ ohms.
- B. C_L includes probe and jig capacitance.
- C. All diodes are 1N3064 or equivalent.
- D. Each reset input is tested separately with the other reset at 4.5 V.
- E. Reference waveforms are shown with dashed lines.
- F. For '90A, '92A, and '93A; $V_{ref} = 1.5$ V. For 'LS90, 'LS92, and 'LS93; $V_{ref} = 1.3$ V.

FIGURE 1B