



MOTOROLA

16,384-BIT DYNAMIC RANDOM ACCESS MEMORY

The MCM4116B is a 16,384-bit, high-speed dynamic Random Access Memory designed for high-performance, low-cost applications in mainframe and buffer memories and peripheral storage. Organized as 16,384 one-bit words and fabricated using Motorola's highly reliable N-channel double-polysilicon technology, this device optimizes speed, power, and density tradeoffs.

By multiplexing row and column address inputs, the MCM4116B requires only seven address lines and permits packaging in Motorola's standard 16-pin dual in-line packages. This packaging technique allows high system density and is compatible with widely available automated test and insertion equipment. Complete address decoding is done on chip with address latches incorporated.

All inputs are TTL compatible, and the output is 3-state TTL compatible. The data output of the MCM4116B is controlled by the column address strobe and remains valid from access time until the column address strobe returns to the high state. This output scheme allows higher degrees of system design flexibility such as common input/output operation and two dimensional memory selection by decoding both row address and column address strobes.

The MCM4116B incorporates a one-transistor cell design and dynamic storage techniques, with each of the 128 row addresses requiring a refresh cycle every 2 milliseconds.

- Flexible Timing with Read-Modify-Write, RAS-Only Refresh, and Page-Mode Capability
- Industry Standard 16-Pin Package
- 16,384 X 1 Organization
- ±10% Tolerance on All Power Supplies
- All Inputs are Fully TTL Compatible
- Three-State Fully TTL-Compatible Output
- Common I/O Capability When Using "Early Write" Mode
- On-Chip Latches for Addresses and Data In
- Low Power Dissipation — 426 mW Active, 20 mW Standby (Max)
- Fast Access Time Options: 150 ns — MCM4116BP-15, BC-15
200 ns — MCM4116BP-20, BC-20
250 ns — MCM4116BP-25, BC-25
300 ns — MCM4116BP-30, BC-30
- Easy Upgrade from 16-Pin 4K RAMs

ABSOLUTE MAXIMUM RATINGS (See Note 1)

Rating	Symbol	Value	Unit
Voltage on Any Pin Relative to V _{BB}	V _{in} -V _{out}	-0.5 to +20	Vdc
Operating Temperature Range	T _A	0 to +70	°C
Storage Temperature Range	T _{stg}	-65 to +150	°C
Power Dissipation	P _D	1.0	W
Data Out Current	I _{out}	50	mA

NOTE 1: Permanent device damage may occur if ABSOLUTE MAXIMUM RATINGS are exceeded. Functional operation should be restricted to RECOMMENDED OPERATING CONDITIONS. Exposure to higher than recommended voltages for extended periods of time could affect device reliability.

MCM4116B

MOS

(N-CHANNEL)

**16,384-BIT DYNAMIC
RANDOM ACCESS
MEMORY**

DRAM

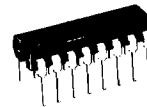

**P SUFFIX
PLASTIC PACKAGE
CASE 648**

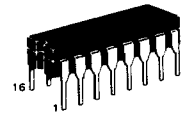

**C SUFFIX
FRIT-SEAL PACKAGE
CASE 620**

PIN ASSIGNMENT

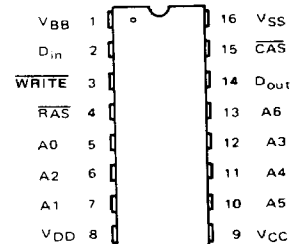

PIN NAMES

- A0-A6 Address Inputs
- CAS Column Address Strobe
- D_{in} Data In
- D_{out} Data Out
- RAS Row Address Strobe
- WRITE Read/Write Input
- V_{BB} Power (-5 V)
- V_{CC} Power (+5 V)
- V_{DD} Power (+12 V)
- V_{SS} Ground

This device contains circuitry to protect the inputs against damage due to high static voltages or electric fields; however, it is advised that normal precautions be taken to avoid application of any voltage higher than maximum rated voltages to this high impedance circuit.

MCM4116B

DRAM

DC OPERATING CONDITIONS AND CHARACTERISTICS (Full operating voltage and temperature range unless otherwise noted.)

RECOMMENDED OPERATING CONDITIONS

Parameter	Symbol	Min	Typ	Max	Unit	Notes
Supply Voltage	V _{DD}	10.8	12.0	13.2	V _{dc}	1
	V _{CC}	4.5	5.0	5.5	V _{dc}	1, 2
	V _{SS}	0	0	0	V _{dc}	1
	V _{BB}	-4.5	-5.0	-5.5	V _{dc}	1
Logic 1 Voltage, RAS, CAS, WRITE	V _{IHC}	2.4	—	7.0	V _{dc}	1
Logic 1 Voltage, all inputs except RAS, CAS, WRITE	V _{IH}	2.4	—	7.0	V _{dc}	1
Logic 0 Voltage, all inputs	V _{IL}	-1.0	—	0.8	V _{dc}	1

DC CHARACTERISTICS (V_{DD} = 12 V ± 10%, V_{CC} = 5.0 V ± 10%, V_{BB} = -5.0 V ± 10%, V_{SS} = 0 V, T_A = 0 to 70°C.)

Characteristic	Symbol	Min	Max	Units	Notes
Average V _{DD} Power Supply Current	I _{DD1}	—	35	mA	4
V _{CC} Power Supply Current	I _{CC}	—	—	mA	5
Average V _{BB} Power Supply Current	I _{BB1,3}	—	200	μA	
Standby V _{BB} Power Supply Current	I _{BB2}	—	100	μA	
Standby V _{DD} Power Supply Current	I _{DD2}	—	1.5	mA	6
Average V _{DD} Power Supply Current during "RAS only" cycles	I _{DD3}	—	27	mA	4
Input Leakage Current (any input)	I _{I(L)}	—	10	μA	
Output Leakage Current	I _{O(L)}	—	10	μA	6, 7
Output Logic 1 Voltage @ I _{out} = -5 mA	V _{OH}	2.4	—	V _{dc}	2
Output Logic 0 Voltage @ I _{out} = 4.2 mA	V _{OL}	—	0.4	V _{dc}	

NOTES:

- All voltages referenced to V_{SS}. V_{BB} must be applied before and removed after other supply voltages.
- Output voltage will swing from V_{SS} to V_{CC} under open circuit conditions. For purposes of maintaining data in power-down mode, V_{CC} may be reduced to V_{SS} without affecting refresh operations. V_{OH(min)} specification is not guaranteed in this mode.
- Several cycles are required after power-up before proper device operation is achieved. Any 8 cycles which perform refresh are adequate.
- Current is proportional to cycle rate; maximum current is measured at the fastest cycle rate.
- I_{CC} depends upon output loading. The V_{CC} supply is connected to the output buffer only.
- Output is disabled (open-circuit) when CAS is at a logic 1.
- 0 V ≤ V_{out} ≤ +5.5 V.
- Capacitance measured with a Bonton Meter or effective capacitance calculated from the equation: $C = \frac{I_{\Delta t}}{\Delta V}$

BLOCK DIAGRAM

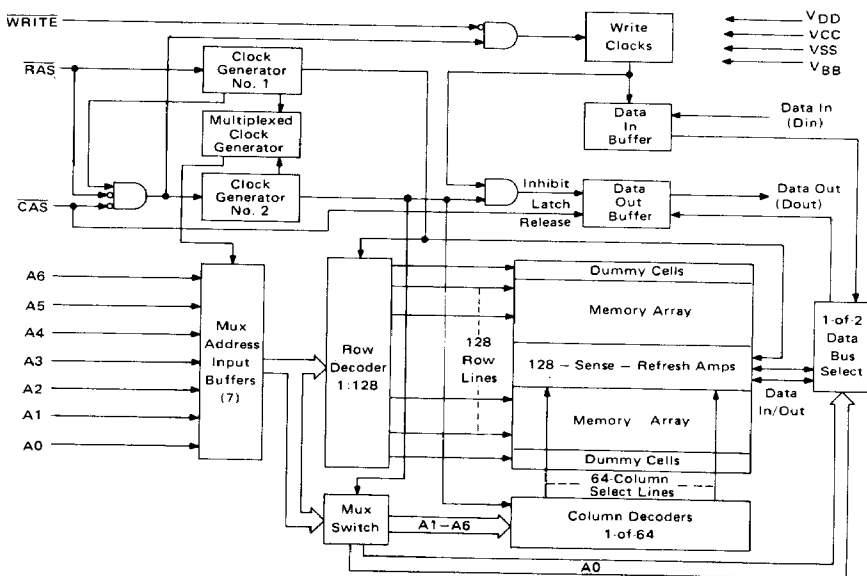

AC OPERATING CONDITIONS AND CHARACTERISTICS (See Notes 3, 9, 14)
(Read, Write, and Read-Modify-Write Cycles)

RECOMMENDED AC OPERATING CONDITIONS

(V_{DD} = 12 V ± 10%, V_{CC} = 5.0 V ± 10%, V_{BB} = -5.0 V ± 10%, V_{SS} = 0 V, T_A = 0 to 70°C.)

Parameter	Symbol	MCM4116B-15		MCM4116B-20		MCM4116B-25		MCM4116B-30		Units	Notes
		Min	Max	Min	Max	Min	Max	Min	Max		
Random Read or Write Cycle Time	t _{RC}	375	—	375	—	410	—	480	—	ns	
Read Write Cycle Time	t _{RWC}	375	—	375	—	515	—	660	—	ns	
Access Time from Row Address Strobe	t _{RAC}	—	150	—	200	—	250	—	300	ns	10, 12
Access Time from Column Address Strobe	t _{CAC}	—	100	—	135	—	165	—	200	ns	11, 12
Output Buffer and Turn-off Delay	t _{OFF}	0	50	0	50	0	60	0	60	ns	17
Row Address Strobe Precharge Time	t _{RP}	100	—	120	—	150	—	180	—	ns	
Row Address Strobe Pulse Width	t _{RAS}	150	10,000	200	10,000	250	10,000	300	10,000	ns	
Column Address Strobe Pulse Width	t _{CAS}	100	10,000	135	10,000	165	10,000	200	10,000	ns	
Row to Column Strobe Lead Time	t _{RCD}	20	50	25	65	35	85	60	100	ns	13
Row Address Setup Time	t _{ASR}	0	—	0	—	0	—	0	—	ns	
Row Address Hold Time	t _{RAH}	20	—	25	—	35	—	60	—	ns	
Column Address Setup Time	t _{ASC}	-10	—	-10	—	-10	—	-10	—	ns	
Column Address Hold Time	t _{CAH}	45	—	55	—	75	—	100	—	ns	
Column Address Hold Time Referenced to RAS	t _{AR}	95	—	120	—	160	—	200	—	ns	
Transition Time (Rise and Fall)	t _T	3.0	35	3.0	50	3.0	50	3.0	50	ns	14
Read Command Setup Time	t _{RCS}	0	—	0	—	0	—	0	—	ns	
Read Command Hold Time	t _{RCH}	0	—	0	—	0	—	0	—	ns	
Write Command Hold Time	t _{WCH}	45	—	55	—	75	—	100	—	ns	
Write Command Hold Time Referenced to RAS	t _{WCR}	95	—	120	—	160	—	200	—	ns	
Write Command Pulse Width	t _{WP}	45	—	55	—	75	—	100	—	ns	
Write Command to Row Strobe Lead Time	t _{RWL}	60	—	80	—	100	—	180	—	ns	
Write Command to Column Strobe Lead Time	t _{CWL}	60	—	80	—	100	—	180	—	ns	
Data in Setup Time	t _{DS}	0	—	0	—	0	—	0	—	ns	15
Data in Hold Time	t _{DH}	45	—	55	—	75	—	100	—	ns	15
Data in Hold Time Referenced to RAS	t _{DHR}	95	—	120	—	160	—	200	—	ns	
Column to Row Strobe Precharge Time	t _{CRP}	-20	—	-20	—	-20	—	-20	—	ns	
RAS Hold Time	t _{RSH}	100	—	135	—	165	—	200	—	ns	
Refresh Period	t _{REFSH}	—	2.0	—	2.0	—	2.0	—	2.0	ms	
WRITE Command Setup Time	t _{WCS}	-20	—	-20	—	-20	—	-20	—	ns	
CAS to WRITE Delay	t _{CWD}	70	—	95	—	125	—	180	—	ns	16
RAS to WRITE Delay	t _{RWD}	120	—	160	—	210	—	280	—	ns	16
CAS Precharge Time (Page mode cycle only)	t _{CP}	60	—	80	—	100	—	100	—	ns	
Page Mode Cycle Time	t _{PC}	170	—	225	—	275	—	325	—	ns	
CAS Hold Time	t _{CSH}	150	—	200	—	250	—	300	—	ns	

NOTES: (continued)

- AC measurements assume t_T = 5.0 ns.
- Assumes that t_{RCD} + t_T ≤ t_{RCD} (max).
- Assumes that t_{RCD} + t_T ≥ t_{RCD} (max).
- Measured with a load circuit equivalent to 2 TTL loads and 100 pF.
- Operation within the t_{RCD} (max) limit ensures that t_{RAC} (max) can be met. t_{RCD} (max) is specified as a reference point only; if t_{RCD} is greater than the specified t_{RCD} (max) limit, then access time is controlled exclusively by t_{CAC}.
- V_{IHC} (min) or V_{IH} (min) and V_{IL} (max) are reference levels for measuring timing of input signals. Also, transition times are measured between V_{IHC} or V_{IH} and V_{IL}.
- These parameters are referenced to CAS leading edge in random write cycles and to WRITE leading edge in delayed write or read-modify-write cycles.
- t_{WCS}, t_{CWD} and t_{RWD} are not restrictive operating parameters. They are included in the data sheet as electrical characteristics only: If t_{WCS} ≥ t_{WCS} (min), the cycle is an early write cycle and the data out pin will remain open circuit (high impedance) throughout the entire cycle; if t_{CWD} ≥ t_{CWD} (min) and t_{RWD} ≥ t_{RWD} (min), the cycle is a read-write cycle and the data out will contain data read from the selected cell; if neither of the above sets of conditions is satisfied the condition of the data out (at access time) is indeterminate.
- Assumes that t_{CRP} > 50 ns.

Parameter	Symbol	Typ	Max	Units	Notes
Input Capacitance (A0-A5), D _{in}	C _{I1}	4.0	5.0	pF	9
Input Capacitance RAS, CAS, WRITE	C _{I2}	8.0	10	pF	9
Output Capacitance (D _{out})	C _O	5.0	7.0	pF	7, 9



MCM4116B

DRAM

READ CYCLE TIMING

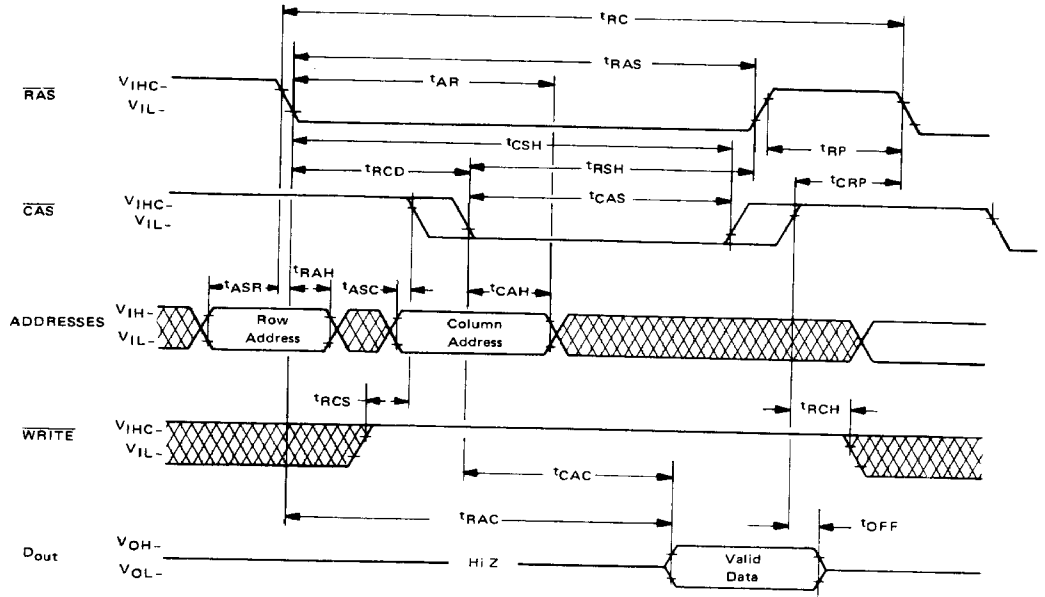

WRITE CYCLE TIMING

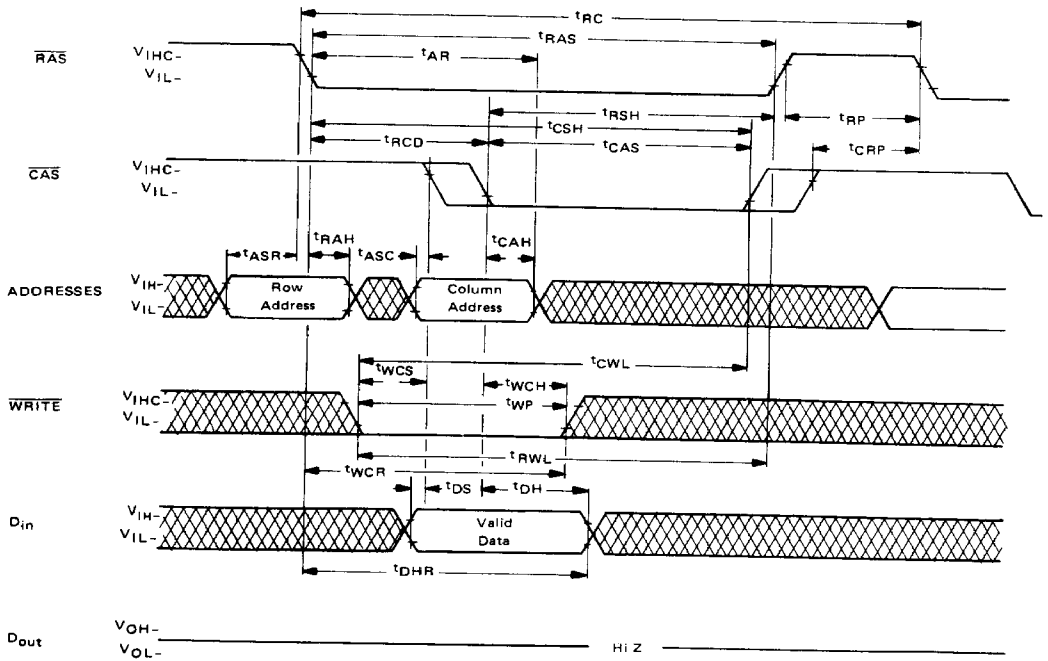

MCM4116B

DRAM

READ-WRITE/READ-MODIFY-WRITE CYCLE

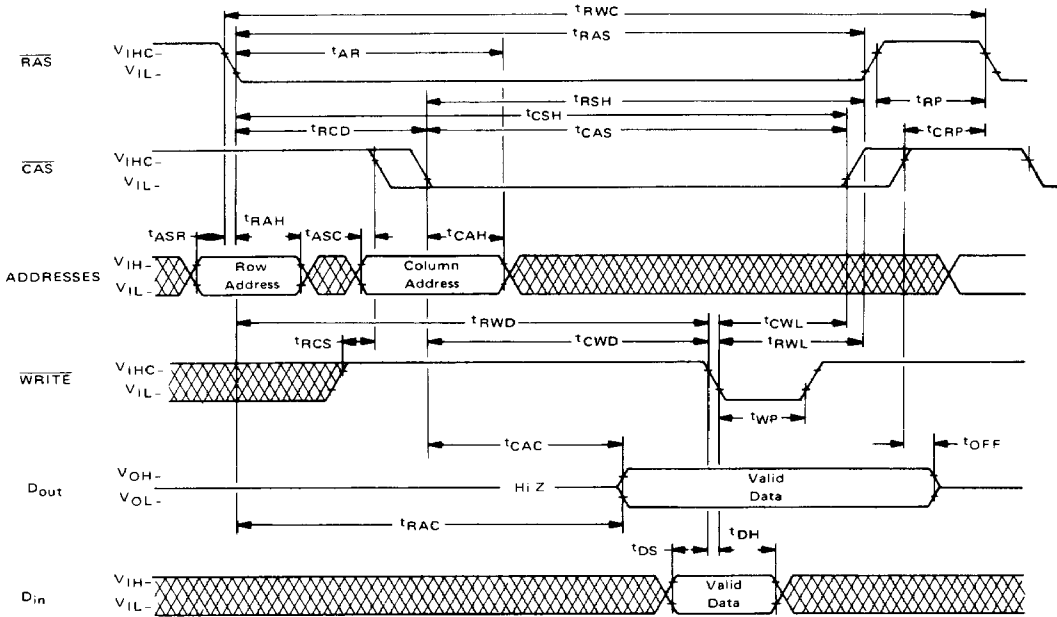

RAS ONLY REFRESH TIMING

Note: $\overline{CAS} = V_{IH}$, WRITE = Don't Care

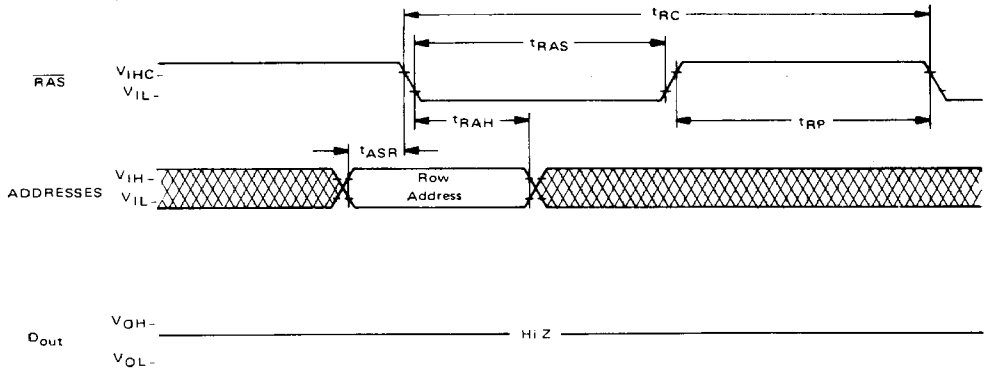

MCM4116B

PAGE MODE READ CYCLE

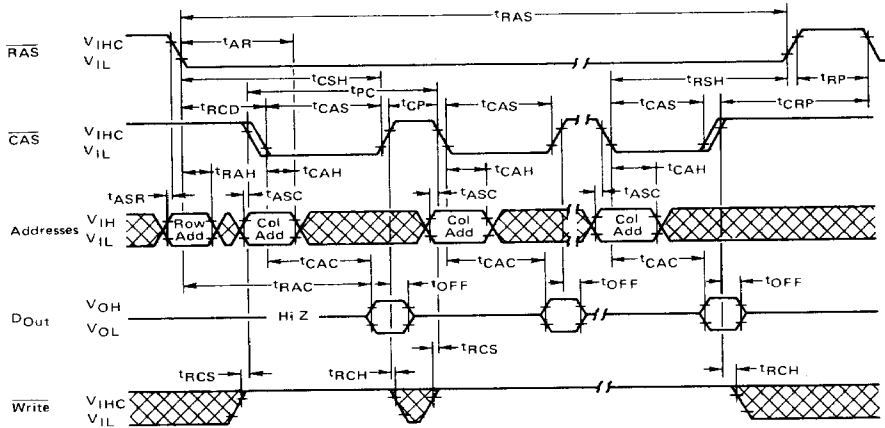

PAGE MODE WRITE CYCLE

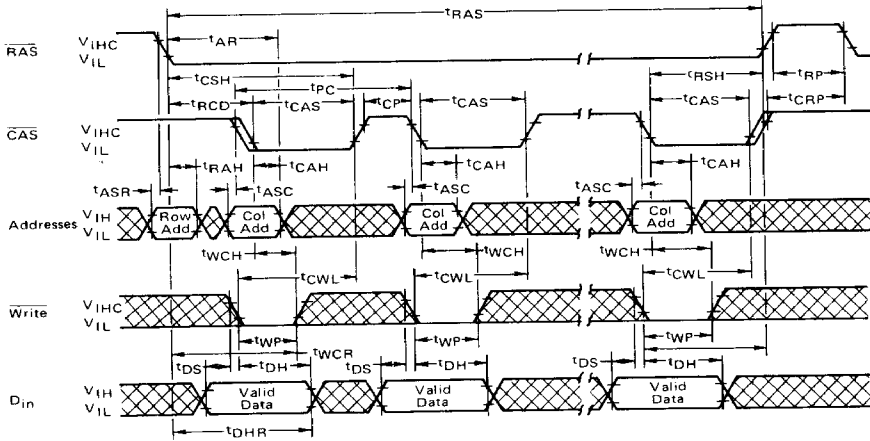

MCM4116B

MCM4116B BIT ADDRESS MAP

Row Address A6 A5 A4 A3 A2 A1 A0
 Column Address A6 A5 A4 A3 A2 A1 A0

Pin 8



Column Addresses

Hex Dec A6 A5 A4 A3 A2 A1 A0

Row Addresses								Column Addresses							
A6	A5	A4	A3	A2	A1	A0	Dec Hex	A6	A5	A4	A3	A2	A1	A0	Dec Hex
0	0	0	0	0	0	0	00	0	0	0	0	0	0	0	00
0	0	0	0	0	0	1	01	0	0	0	0	0	1	01	
0	0	0	0	0	1	0	02	0	0	0	0	1	0	02	
0	0	0	0	1	0	0	03	0	0	0	1	0	0	03	
0	0	0	1	0	0	0	04	0	0	1	0	0	0	04	
0	0	0	1	0	1	0	05	0	0	0	1	0	1	05	
0	0	0	1	1	0	0	06	0	0	0	1	1	0	06	
0	0	0	1	1	1	0	07	0	0	0	1	1	1	07	
0	0	1	0	0	0	0	08	1	0	0	0	0	0	08	
0	1	1	1	1	1	1	63 3F	1	0	0	0	0	0	64 40	
0	1	1	1	1	1	0	09	1	1	1	1	1	1	127 7F	
0	1	1	1	1	0	1	0A	1	1	1	1	0	0	128 80	
0	1	1	1	0	0	0	0B	1	1	1	0	0	0	129 81	
0	1	1	0	0	0	0	0C	1	1	0	0	0	0	130 82	
0	1	0	0	0	0	0	0D	1	1	0	0	1	0	131 83	
0	1	0	0	1	0	0	0E	1	1	0	1	0	0	132 84	
0	1	0	1	0	0	0	0F	1	1	0	1	1	0	133 85	
0	1	0	1	1	0	0	10	1	1	0	1	1	1	134 86	
0	1	0	1	1	1	0	11	1	1	0	1	1	1	135 87	
0	1	0	0	0	1	0	12	1	1	0	0	0	1	136 88	
0	1	0	0	0	1	1	13	1	1	0	0	0	1	137 89	
0	1	0	0	1	0	0	14	1	1	0	0	1	0	138 8A	
0	1	0	0	1	1	0	15	1	1	0	0	1	1	139 8B	
0	1	0	1	0	0	0	16	1	1	0	1	0	0	140 8C	
0	1	0	1	0	0	1	17	1	1	0	1	0	1	141 8D	
0	1	0	1	1	0	0	18	1	1	0	1	0	1	142 8E	
0	1	0	1	1	1	0	19	1	1	0	1	1	0	143 8F	
0	1	0	0	0	0	1	1A	1	1	0	0	0	1	144 90	
0	1	0	0	0	0	1	1B	1	1	0	0	0	1	145 91	
0	1	0	0	1	0	0	1C	1	1	0	0	1	0	146 92	
0	1	0	0	1	1	0	1D	1	1	0	0	1	1	147 93	
0	1	0	1	0	0	0	1E	1	1	0	1	0	0	148 94	
0	1	0	1	0	0	1	1F	1	1	0	1	0	1	149 95	
0	1	0	1	1	0	0	20	1	1	0	1	1	0	150 96	
0	1	0	1	1	1	0	21	1	1	0	1	1	0	151 97	
0	1	0	0	0	1	0	22	1	1	0	0	0	1	152 98	
0	1	0	0	0	1	1	23	1	1	0	0	0	1	153 99	
0	1	0	0	1	0	0	24	1	1	0	0	1	0	154 9A	
0	1	0	0	1	1	0	25	1	1	0	0	1	0	155 9B	
0	1	0	1	0	0	0	26	1	1	0	1	0	0	156 9C	
0	1	0	1	0	0	1	27	1	1	0	1	0	0	157 9D	
0	1	0	1	1	0	0	28	1	1	0	1	0	0	158 9E	
0	1	0	1	1	1	0	29	1	1	0	1	0	0	159 9F	
0	1	0	0	0	0	0	2A	1	1	0	0	0	0	160 A0	
0	1	0	0	0	0	1	2B	1	1	0	0	0	0	161 A1	
0	1	0	0	1	0	0	2C	1	1	0	0	1	0	162 A2	
0	1	0	0	1	1	0	2D	1	1	0	0	1	0	163 A3	
0	1	0	1	0	0	0	2E	1	1	0	1	0	0	164 A4	
0	1	0	1	0	0	1	2F	1	1	0	1	0	0	165 A5	
0	1	0	1	1	0	0	30	1	1	0	1	0	0	166 A6	
0	1	0	1	1	1	0	31	1	1	0	1	0	0	167 A7	
0	1	0	0	0	0	0	32	1	1	0	0	0	0	168 A8	
0	1	0	0	0	0	1	33	1	1	0	0	0	0	169 A9	
0	1	0	0	0	1	0	34	1	1	0	0	0	1	170 AA	
0	1	0	0	0	1	1	35	1	1	0	0	0	1	171 AB	
0	1	0	0	1	0	0	36	1	1	0	0	0	0	172 AC	
0	1	0	0	1	0	1	37	1	1	0	0	0	0	173 AD	
0	1	0	0	1	1	0	38	1	1	0	0	0	0	174 AE	
0	1	0	0	1	1	1	39	1	1	0	0	0	0	175 AF	
0	1	0	1	0	0	0	3A	1	1	0	1	0	0	176 B0	
0	1	0	1	0	0	1	3B	1	1	0	1	0	0	177 B1	
0	1	0	1	0	1	0	3C	1	1	0	1	0	0	178 B2	
0	1	0	1	0	1	1	3D	1	1	0	1	0	0	179 B3	
0	1	0	1	1	0	0	3E	1	1	0	1	0	0	180 B4	
0	1	0	1	1	0	1	3F	1	1	0	1	0	0	181 B5	
0	1	0	1	1	1	0	40	1	1	0	1	0	0	182 B6	
0	1	0	1	1	1	1	41	1	1	0	1	0	0	183 B7	
0	1	1	0	0	0	0	42	1	1	1	0	0	0	184 B8	
0	1	1	0	0	0	1	43	1	1	1	0	0	0	185 B9	
0	1	1	0	0	1	0	44	1	1	1	0	0	0	186 BA	
0	1	1	0	0	1	1	45	1	1	1	0	0	0	187 BB	
0	1	1	0	1	0	0	46	1	1	1	0	0	0	188 BC	
0	1	1	0	1	0	1	47	1	1	1	0	0	0	189 BD	
0	1	1	0	1	1	0	48	1	1	1	0	0	0	190 BE	
0	1	1	0	1	1	1	49	1	1	1	0	0	0	191 BF	
0	1	1	1	0	0	0	4A	1	1	1	0	0	0	192 C0	
0	1	1	1	0	0	1	4B	1	1	1	0	0	0	193 C1	
0	1	1	1	0	1	0	4C	1	1	1	0	0	0	194 C2	
0	1	1	1	0	1	1	4D	1	1	1	0	0	0	195 C3	
0	1	1	1	1	0	0	4E	1	1	1	0	0	0	196 C4	
0	1	1	1	1	0	1	4F	1	1	1	0	0	0	197 C5	
0	1	1	1	1	1	0	50	1	1	1	0	0	0	198 C6	
0	1	1	1	1	1	1	51	1	1	1	0	0	0	199 C7	
0	1	1	0	0	0	0	52	1	1	1	0	0	0	200 C8	
0	1	1	0	0	0	1	53	1	1	1	0	0	0	201 C9	
0	1	1	0	0	1	0	54	1	1	1	0	0	0	202 CA	
0	1	1	0	0	1	1	55	1	1	1	0	0	0	203 CB	
0	1	1	0	1	0	0	56	1	1	1	0	0	0	204 CC	
0	1	1	0	1	0	1	57	1	1	1	0	0	0	205 CD	
0	1	1	0	1	1	0	58	1	1	1	0	0	0	206 CE	
0	1	1	0	1	1	1	59	1	1	1	0	0	0	207 CF	
0	1	1	1	0	0	0	5A	1	1	1	0	0	0	208 D0	
0	1	1	1	0	0	1	5B	1	1	1	0	0	0	209 D1	
0	1	1	1	0	1	0	5C	1	1	1	0	0	0	210 D2	
0	1	1	1	0	1	1	5D	1	1	1	0	0	0	211 D3	
0	1	1	1	1	0	0	5E	1	1	1	0	0	0	212 D4	
0	1	1	1	1	0	1	5F	1	1	1	0	0	0	213 D5	
0	1	1	1	1	1	0	60	1	1	1	0	0	0	214 D6	
0	1	1	1	1	1	1	63 3F	1	1	1	0	0	0	215 D7	
0	1	1	0	0	0	0	64 40	1	1	1	0	0	0	216 D8	
0	1	1	0	0	0	1	65 41	1	1	1	0	0	0	217 D9	
0	1	1	0	0	1	0	66 42	1	1	1	0	0	0	218 DA	
0	1	1	0	0	1	1	67 43	1	1	1	0	0	0	219 DB	
0	1	1	0	1	0	0	68 44	1	1	1	0	0	0	220 DC	
0	1	1	0	1	0	1	69 45	1	1	1	0	0	0	221 DD	
0	1	1	0	1	1	0	6A 46	1	1	1	0	0	0	222 DE	
0	1	1	0	1	1	1	6B 47	1	1	1	0	0	0	223 DF	
0	1	1	1	0	0	0	6C 48	1	1	1	0	0	0	224 E0	
0	1	1	1	0	0	1	6D 49	1	1	1	0	0	0	225 E1	
0	1	1	1	0	1	0	6E 4A	1	1	1	0	0	0	226 E2	
0	1	1	1	0	1	1	6F 4B	1	1	1	0	0	0	227 E3	
0	1	1	1	1	0	0	70 4C	1	1	1	0	0	0	228 E4	
0	1	1	1	1	0	1	71 4D	1	1	1	0	0	0	229 E5	
0	1	1	1	1	1	0	72 4E								