

HS-C²MOS™ INTEGRATED CIRCUITS

040637

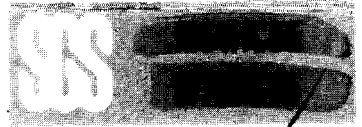

PRELIMINARY DATA

4-BIT MAGNITUDE COMPARATOR

DESCRIPTION

The M54/74HC85 is a high speed CMOS 4-BIT MAGNITUDE COMPARETOR fabricated in silicon gate C²MOS technology. It has the same high speed performance of LSTTL combined with true CMOS low power consumption. This comparator compares two 4-bit words and provides a high voltage level on one of the A > Bout, A = Bout and A < Bout outputs. The comparing bit number is easily expanded by cascading several devices as shown in the typical application. All inputs are equipped with protection circuits against static discharge or transient excess voltage.

B1 Plastic Package **F1** Ceramic Package **C1** Chip Carrier

ORDERING NUMBERS: M54HC85 F1
M74HC85 B1
M74HC85 F1
M74HC85 C1

FEATURES

- High Speed
 $t_{PD} = 28 \text{ ns (Typ.) at } V_{CC} = 5 \text{ V}$
- Low Power Dissipation
 $I_{CC} = 4 \mu\text{A (Max.) at } T_A = 25^\circ\text{C}$
- High Noise Immunity
 $V_{NIH} = V_{NIL} = 28\% V_{CC} \text{ (Min.)}$
- Output Drive Capability
10 LSTTL Loads
- Symmetrical Output Impedance
 $|I_{OH}| = I_{OL} = 4 \text{ mA (Min.)}$
- Balanced Propagation Delays
 $t_{PLH} = t_{PHL}$
- Wide Operating Voltage Range
 $V_{CC} \text{ (opr)} = 2 \text{ V to } 6 \text{ V}$
- Pin and Function compatible with 54/74LS85

PIN CONNECTIONS (top view)

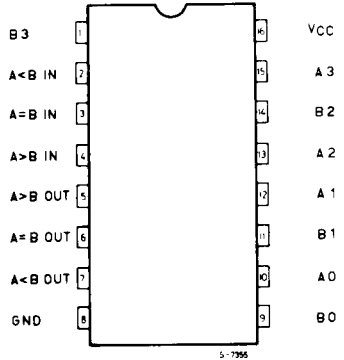

Dual in line CHIP CARRIER

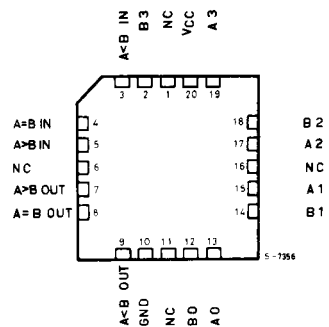

NC = No Internal Connection

INPUT AND OUTPUT EQUIVALENT CIRCUIT

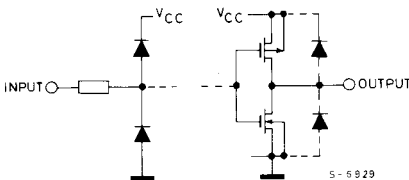



LOGIC DIAGRAM

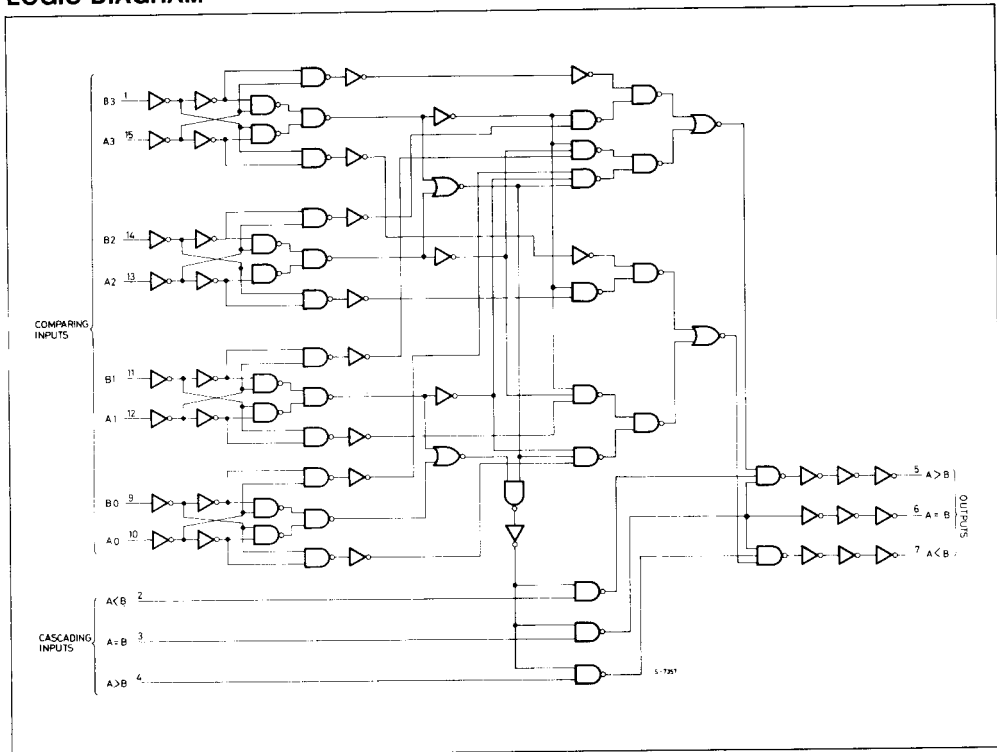

TRUTH TABLE

COMPARING INPUTS				CASCADING INPUTS			OUTPUTS		
				A > B	A < B	A = B	A > B	A < B	A = B
A3 > B3	X	X	X	X	X	X	H	L	L
A3 = B3	A2 > B2	X	X	X	X	X	H	L	L
A3 = B3	A2 = B2	A1 > B1	X	X	X	X	H	L	L
A3 = B3	A2 = B2	A1 = B1	A0 > B0	X	X	X	H	L	L
A3 = B3	A2 = B2	A1 = B1	A0 = B0	L	L	L	H	H	L
				X	X	H	L	L	H
				L	H	L	L	H	L
				H	L	L	L	L	L
A3 = B3	A2 = B2	A1 = B1	A0 < B0	X	X	X	L	H	L
				X	X	X	L	H	L
				X	X	X	L	H	L
				X	X	X	L	H	L

X: Don't Care



M54HC85
M74HC85

ABSOLUTE MAXIMUM RATINGS

Symbol	Parameter	Value	Unit
V _{CC}	Supply Voltage	- 0.5 to 7	V
V _I	DC Input Voltage	- 0.5 to V _{CC} + 0.5	V
V _O	DC Output Voltage	- 0.5 to V _{CC} + 0.5	V
I _{IJK}	DC Input Diode Current	± 20	mA
I _{OK}	DC Output Diode Current	± 20	mA
I _O	DC Output Source Sink Current Per Output Pin	± 25	mA
I _{CC} or I _{GND}	DC V _{CC} or Ground Current	± 50	mA
P _D	Power Dissipation	500 (*)	mW
T _{stg}	Storage Temperature	- 65 to 150	°C

Absolute Maximum Ratings are those values beyond which damage to the device may occur. Functional operation under these conditions is not implied.

(*) 500 mW: ≅ 65°C derate to 300 mW by 10 mW/°C: 65°C to 85°C.

RECOMMENDED OPERATING CONDITIONS

Symbol	Parameter	Limit	Unit
V _{CC}	Supply Voltage	2 to 6	V
V _I	Input Voltage	0 to V _{CC}	V
V _O	Output Voltage	0 to V _{CC}	V
T _A	Operating Temperature 74HC Series 54HC Series	- 40 to 85 - 55 to 125	°C
t _r , t _f	Input Rise and Fall Time	V _{CC} { 2 V, 4.5V, 6 V } 0 to 1000 0 to 500 0 to 400	ns

DC SPECIFICATIONS

Symbol	Parameter	V _{CC}	Test Condition	T _A = 25°C 54HC and 74HC			- 40 to 85°C 74HC		- 55 to 125°C 54HC		Unit	
				Min.	Typ.	Max.	Min.	Max.	Min.	Max.		
V _{IH}	High Level Input Voltage	2.0		1.5	—	—	1.5	—	1.5	—	V	
		4.5		3.15	—	—	3.15	—	3.15	—		
		6.0		4.2	—	—	4.2	—	4.2	—		
V _{IL}	Low Level Input Voltage	2.0		—	—	0.5	—	0.5	—	0.5	V	
		4.5		—	—	1.35	—	1.35	—	1.35		
		6.0		—	—	1.8	—	1.8	—	1.8		
V _{OH}	High Level Output Voltage	2.0	V _I	I _O	1.9	2.0	—	1.9	—	1.9	—	V
					4.5	4.4	4.5	—	4.4	—	4.4	
		6.0	V _{IH}	5.9	6.0	—	5.9	—	5.9	—		
				4.5	—	—	4.13	—	4.10	—		
		6.0	V _{IL}	- 4.0 mA	4.18	4.31	—	4.13	—	4.10	—	
				- 5.2 mA	5.68	5.8	—	5.63	—	5.60	—	



M54HC85

M74HC85

DC SPECIFICATIONS (Continued)

Symbol	Parameter	V _{CC}	Test Condition		T _A = 25°C 54HC and 74HC			- 40 to 85°C 74HC		- 55 to 125°C 54HC		Unit
					Min.	Typ.	Max.	Min.	Max.	Min.	Max.	
V _{OL}	Low Level Output Voltage	2.0	V _I	I _O	—	0	0.1	—	0.1	—	0.1	V
		4.5	V _{IH}	20 μA	—	0	0.1	—	0.1	—	0.1	
		6.0	or		—	0	0.1	—	0.1	—	0.1	
		4.5	V _{IL}	4.0 mA	—	0.17	0.26	—	0.33	—	0.40	
		6.0			5.2 mA	—	0.18	0.26	—	0.33	—	
I _I	Input Leakage Current	6.0	V _I = V _{CC} or GND		—	—	±0.1	—	±1		±1	μA
I _{CC}	Quiescent Supply Current	6.0	V _I = V _{CC} or GND		—	—	4	—	40		80	μA

AC ELECTRICAL CHARACTERISTICS (V_{CC} = 5V, T_A = 25°C, C_L = 15pF, Input t_r = t_f = 6ns)

Symbol	Parameter	54HC and 74HC			Unit
		MIN.	TYP.	MAX.	
t _{TLH} t _{THL}	Output Transition Time		4	8	ns
t _{PLH} t _{PHL}	Propagation Delay Time (A, B, - OUT)		26	41	ns
t _{PLH} t _{PHL}	Propagation Delay Time (CASCADE - OUT)		12	20	ns

AC ELECTRICAL CHARACTERISTICS (C_L = 50pF, Input t_r = t_f = 6ns)

Symbol	Parameter	V _{CC}	Test Condition		T _A = 25°C 54HC and 74HC			- 40 to 85°C 74HC		- 55 to 125°C 54HC		Unit
					Min.	Typ.	Max.	Min.	Max.	Min.	Max.	
t _{TLH} t _{THL}	Output Transition Time	2.0 4.5 6.0			— — —	22 8 7	75 15 13	— — —	90 18 16			ns
t _{PLH} t _{PHL}	Propagation Delay Time (A, B, - OUT)	2.0 4.5 6.0			— — —	140 30 26	235 47 40	— — —	285 57 49			ns
t _{PLH} t _{PHL}	Propagation Delay Time (CASCADE - OUT)	2.0 4.5 6.0			— — —	60 15 13	120 24 21	— — —	145 29 25			ns
C _{IN}	Input Capacitance				—	5	10	—	10			pF
C _{PD} (*)	Power Dissipation Capacitance					28						pF

Note (*) C_{PD} is defined as the value the IC's of internal equivalent capacitance which is calculated from the operating current consumption without load.