



M.S.KENNEDY CORP.

DUAL HIGH VOLTAGE/
HIGH CURRENT
OPERATIONAL AMPLIFIER

182/183/
184

4707 Dey Road Liverpool, N.Y. 13088

(315) 701-6751

FEATURES:

- MSK184 Replaces APEX PA21 and PA74
- Available to DSCC SMD 5962-92152
- Space Efficient Dual Amplifiers
- High Voltage Operation:
 - Single Supply: + 8V to + 60V
 - Dual Supply: $\pm 4V$ to $\pm 30V$
- High Output Current: 3 Amp Continuous per amplifier
- High Speed: 10V/ μ S
- Low Quiescent Current: 20 mA per amplifier Typ.
- Adjustable Current Limits
- Thermal Shutdown
- Enable/Status Pin For Output Disable Control
- Contact MSK for MIL-PRF-38534 Qualification Status

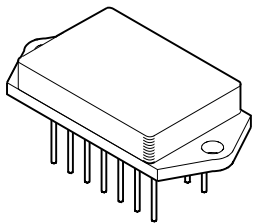

MSK182

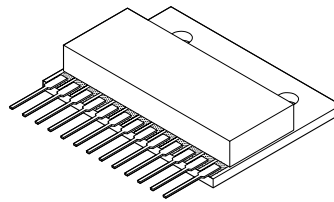

MSK183

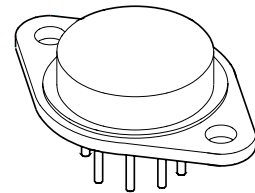

MSK184

DESCRIPTION:

The MSK 182, 183 and 184 are dual high power monolithic operational amplifiers ideal for use with a wide variety of loads. With operation from either single or dual supplies, they offer excellent design flexibility. Power dissipation is kept to a minimum with a quiescent current rating of only 20mA per amplifier, while 3 Amps of continuous available output current makes them a very good low cost choice for motor drive circuits and audio amplification. The design is internally protected against current overloads and overtemperature conditions. On the MSK 182 and MSK 183, current limit can also be user-selected through the use of a resistor/potentiometer or voltage out/current out DAC. The MSK 182 is packaged in a hermetically sealed 14 pin power DIP with bolt down tabs for applications that require heat sinking. The MSK 183 is packaged in a low cost ceramic SIP and the MSK 184 is packaged in a TO-3.

TYPICAL APPLICATIONS

- Servo Driver
- Actuator Driver
- Audio Amplifier
- Power Supplies
- Bridge Amps
- Stereo Amps

EQUIVALENT SCHEMATIC

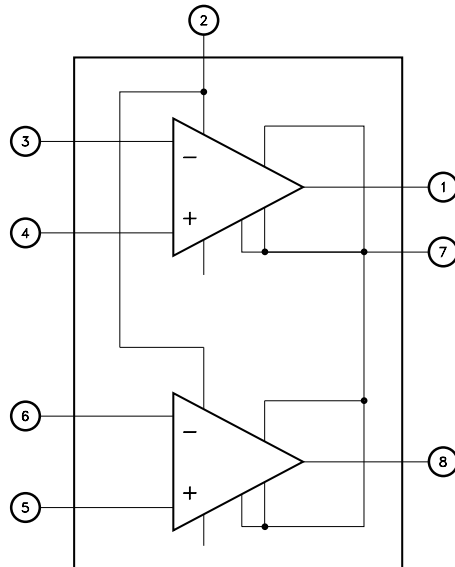
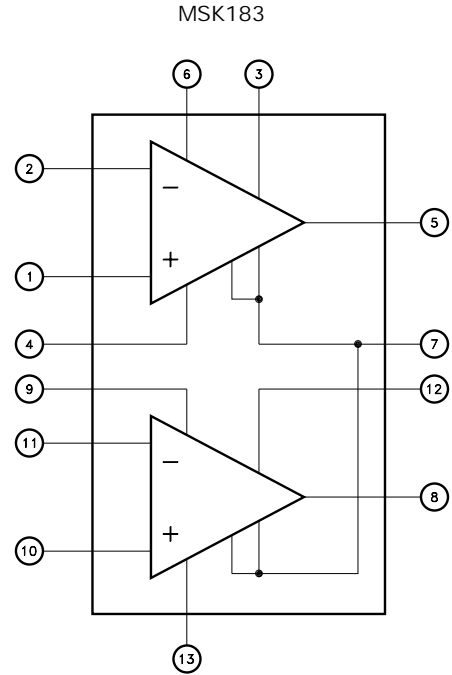
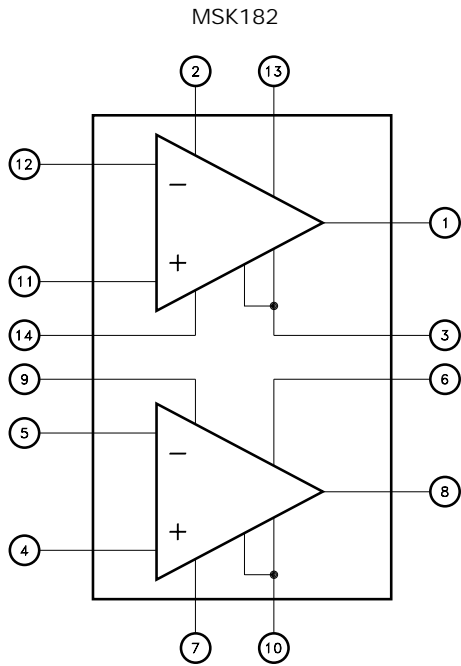

PIN-OUT INFORMATION

1 OUTPUT 1	14 E/S 1
2 +Vcc 1	13 ILIM 1
3 -Vcc 1	12 -VIN 1
4 +VIN 2	11 +VIN 1
5 -VIN 2	10 -Vcc 2
6 ILIM 2	9 +Vcc 2
7 E/S 2	8 OUTPUT 2

MSK 182 PINOUT

1 +VIN 1	13 E/S 2
2 -VIN 1	12 ILIM 2
3 ILIM 1	11 -VIN 2
4 E/S 1	10 +VIN 2
5 OUTPUT 1	9 +VCC 2
6 +VCC 1	8 OUTPUT 2
7 -VCC 1/2	

MSK 183 PINOUT

1 OUTPUT(1)
2 +VCC(1/2)
3 -VIN(1)
4 +VIN(1)
5 +VIN(2)
6 -VIN(2)
7 -VCC(1/2)
8 OUTPUT(2)

MSK 184 PINOUT

ABSOLUTE MAXIMUM RATINGS ^⑩

V _{CC}	Total Supply Voltage	60V
± I _{OUT}	Output Current (within S.O.A.)	5A
V _{IND}	Input Voltage (Differential)	± 29.5V
V _{IN}	Input Voltage (Common Mode)	+ 27V/-29V
T _J	Junction Temperature . . . Internal Protection (See Application Note)	

T _{ST}	Storage Temperature Range	-65°C to + 150°C
T _{LD}	Lead Temperature Range (10 seconds)	300°C
T _C	Case Operating Temperature (MSK182G/E/184G/E) See Note 9	-40°C to + 125°C
	(MSK182/183/184)	-25°C to + 85°C
R _{TH}	Thermal Resistance (Per Amplifier)	
	MSK182 - Junction to Case @ 125°C	1.8°C/W
	MSK183 - Junction to Case @ 85°C	3.8°C/W
	MSK184 - Junction to Case @ 125°C	3.5°C/W

ELECTRICAL SPECIFICATIONS

Parameter	Test Conditions ^① ^②	Group A Subgroup	MSK182G/E 184G/E			MSK182/MSK183/ MSK184			Units
			Min.	Typ.	Max.	Min.	Typ.	Max.	
STATIC									
Supply Voltage Range ^③		-	± 4	-	± 30	± 4	-	± 30	V
Quiescent Current (Per Amp)	V _{IN} = 0V	1	-	± 17	± 20	-	± 17	± 23	mA
		2,3	-	± 17	± 20	-	-	-	mA
Quiescent Current (Per Amp) ^⑦	Shutdown Mode V _{IN} = 0V	-	-	± 6	-	-	± 6	-	mA
INPUT									
Input Offset Voltage	V _{IN} = 0V	1	-	± 2	± 10	-	± 2	± 15	mV
Input Offset Voltage Drift	V _{IN} = 0V	-	-	± 30	-	-	± 30	-	µV/°C
Input Bias Current ^③	V _{IN} = 0V	1	-	± 100	± 500	-	± 100	± 750	nA
Input Offset Current ^③	V _{IN} = 0V	1	-	± 5	± 50	-	± 5	± 75	nA
Input Impedance	f = DC	-	-	10 ⁷	-	-	10 ⁷	-	Ω
Input Capacitance	f = DC	-	-	6	-	-	6	-	pF
Common Mode Rejection Ratio ^③ (-V _{CC})-0.1 ≤ V _{IN} ≤ (+ V _{CC})-3V		1	80	95	-	75	95	-	dB
Input Voltage Noise Density	f = 1KHz	-	-	90	-	-	90	-	nV/√Hz
OUTPUT									
Output Voltage Swing	I _{OUT} = 0.6A ^③	4	± 27	± 28	-	± 27	± 28	-	V
	I _{OUT} = 3.0A	4	± 25.5	± 26	-	± 25	± 26	-	V
Output Current	DC = Continuous	4	± 3	-	-	± 3	-	-	A
Shutdown Input ^③ ^⑦	V _{E/S} High- Output Enabled E/S Open or High	4	-27.5	-	-	-27.5	-	-	V
	V _{E/S} Low- Output Disabled E/S Forced Low	4	-	-	-29	-	-	-29	V
	I _{E/S} High- Output Enabled E/S Open or High	-	-	-65	-	-	-65	-	µA
	I _{E/S} Low- Output Disabled E/S Forced Low	-	-	-70	-	-	-70	-	µA
Output Disable Time ^⑦		-	-	1	-	-	1	-	µS
Output Enable Time ^⑦		-	-	3	-	-	3	-	µS
TRANSFER CHARACTERISTICS									
Slew Rate	A _V = 1 V _{OUT} = 50Vp-p R _L = 8Ω	-	-	10	-	-	8	-	V/µS
Open Loop Voltage Gain ^③	V _{OUT} = ± 25V R _L = 1KΩ	4	90	98	-	88	98	-	dB
Settling Time ± 0.1% ^③	A _V = 10 50V Step	-	-	15	-	-	18	-	µS

NOTES:

- ① Unless otherwise specified ± V_{CC} = ± 30VDC and E/S pin is open for MSK 182 and MSK 183.
- ② All electrical specifications apply to each amplifier.
- ③ Devices shall be capable of meeting the parameter, but need not to be tested. Typical parameters are for reference only.
- ④ Industrial grade and 'E' suffix devices shall be tested to subgroups 1 and 4 unless otherwise specified.
- ⑤ Military grade devices ('G' suffix) shall be 100% tested to subgroups 1,2,3 and 4.
- ⑥ Subgroup 1,4 T_A = T_C = + 25°C
Subgroup 2 T_A = T_C = + 125°C
Subgroup 3 T_A = T_C = -40°C
- ⑦ Does not apply to MSK 184.
- ⑧ Refer to SMD 5962-92152 for electrical parameters for devices purchased as such.
- ⑨ The operating temperature range is -55°C to + 125°C if the device is powered. The minimum cold start temperature is -40°C.
- ⑩ Continuous operation at or above absolute maximum rating may adversely effect the device performance and/or life cycle.

APPLICATION NOTES

POWER SUPPLIES:

For the MSK 182/183/184 maximum total supply voltage is specified as 60V. However, dual and unbalanced power supply operation is permissible as long as total supply voltage does not exceed 60V.

POWER SUPPLY BYPASSING:

Power supply terminals must be effectively decoupled with a high and low frequency bypass circuit to avoid power supply induced oscillation. An effective decoupling scheme consists of a 0.1µF ceramic capacitor in parallel with a 10µF tantalum capacitor for each power supply pin to ground. In addition, it is recommended that a 0.01µF capacitor be placed between ±Vcc as close to the amplifiers as possible.

CURRENT LIMIT:

The MSK 182 and MSK 183 offer accurate, user-selectable current limit. Unlike typical designs that use a power resistor in series with the output to sense load, the MSK 182 and MSK 183 sense the load indirectly and therefore do not require a resistor to handle the full output current. Current limit is selected by controlling the input to the I_{LIM} pin.

The easiest method is to use a resistor or potentiometer connected between -Vcc and the I_{LIM} pin. Use the following equation to select proper resistor value:

$$R_{CC} = \frac{71,250}{I_{LIM}} - 13.75K\Omega$$

A low level control signal (0-330µA) can also be used to control the current level digitally. If the pin is left open, the current is programmed to OA, while connecting I_{LIM} directly to -Vcc sets the output current to it's maximum, typically 5A. Such is the case with the MSK 184.

SAFE OPERATING AREA:

The safe operating area curve is a graphical representation of the power handling capability of the amplifier under various conditions. Power dissipation of the device is equal to the product of the voltage across the output transistor times the output current. As can be seen in the curve on page 6, safe operating current decreases with an increase in temperature as well as an increase in the voltage across the output transistor. Therefore, for maximum amplifier performance it is important to keep case temperature as low as possible and to keep ±Vcc as close to the output rail as achievable.

THERMAL PROTECTION:

The amplifiers are equipped with thermal protection circuitry that protects each amplifier from damage caused by excessive junction temperature. The output is disabled when the junction temperature reaches approximately 160°C. After the junction temperature cools to approximately 140°C, the output is again enabled. The thermal protection may cycle on and off depending on the output load and signal conditions; this may have an undesirable effect on the load.

It should be noted that even though this internal protection circuitry does protect against overload conditions, it does not take the place of proper heat sinking. For reliable operation, junction temperature should be limited to 150°C, maximum.

ENABLE/STATUS PIN:

For the MSK 182 and MSK 183 this pin actually has a dual function. First, when the pin is forced low, the output stage is disabled. Second, it can be monitored to determine if the device is in thermal shutdown. These functions can be used on the same device with either single or dual supplies. For normal operation, the E/S pin must be left open or pulled at least 2.4 volts above the negative rail. In noisy applications, a small value capacitor between the E/S pin and -Vcc may be required.

To disable the output, the user must pull the E/S pin low, no greater than 0.8V above -Vcc. To once again enable the device, the E/S pin must be brought at least 2.4 volts above -Vcc or be disconnected. It should be noted that when the E/S pin is high, the internal thermal shutdown is still active.

If the E/S pin is used to monitor thermal shutdown, during normal operation the voltage on the E/S pin is typically 3.5V above -Vcc. Once shutdown has occurred this voltage will drop to approximately 350mV above -Vcc. This function is not available on the MSK 184.

COMPENSATION:

For normal operation output compensation is not typically required. However, if the MSK 182 or MSK 183 is intended to be driven into current limit the user may find that an R/C network is required. A snubber network from the output to ground for each amplifier will provide stability. If driving large capacitive or inductive loads, a snubber network will also enhance stability. Typically 3Ω to 10Ω in series with 0.01µF is acceptable.

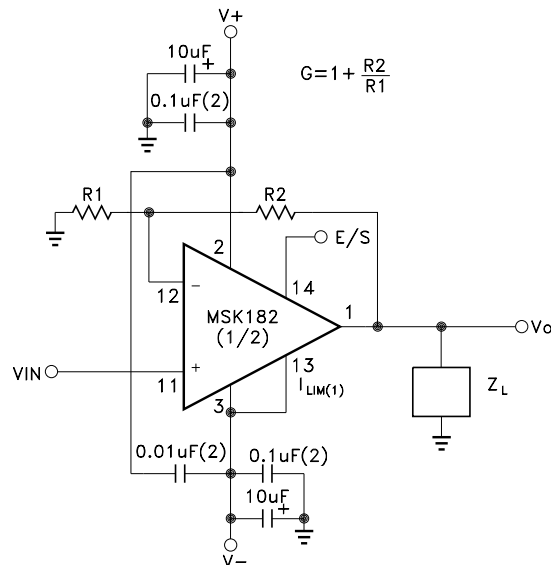

NOTE: (1) I_{LIM} connected to V- achieves the maximum current limit, 5A(peak). (2) Connect capacitors directly to package power supply pins.

TYPICAL CONNECTION DIAGRAM

APPLICATION NOTES cont.

RESISTOR METHOD

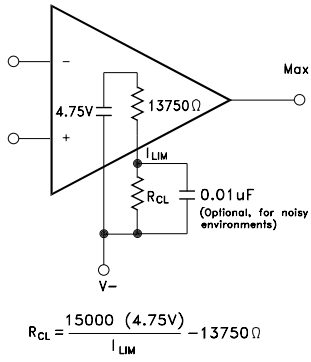

DAC METHOD (Current or voltage)

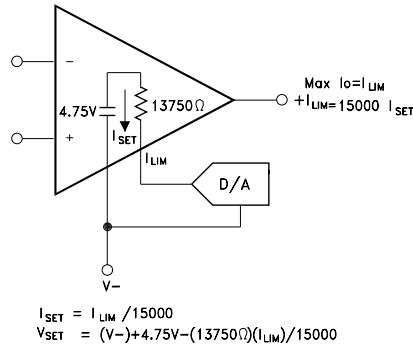

DESIRED CURRENT LIMIT	RESISTOR(1) (RCL)	CURRENT (ISET)	VOLTAGE (VSET)
0A	I_{LIM} Open	0uA	(V-)+4.75V
1A	57.6KΩ	67uA	(V-)+3.8V
2.5A	14.7KΩ	167uA	(V-)+2.5V
3A	10KΩ	200uA	(V-)+2V
4A	4.02KΩ	267uA	(V-)+1.1V
5A	I_{LIM} Connected to V-	333uA	(V-)

NOTE: (1) Resistors are nearest standard 1% values.

Figure 1 Adjustable Current Limit

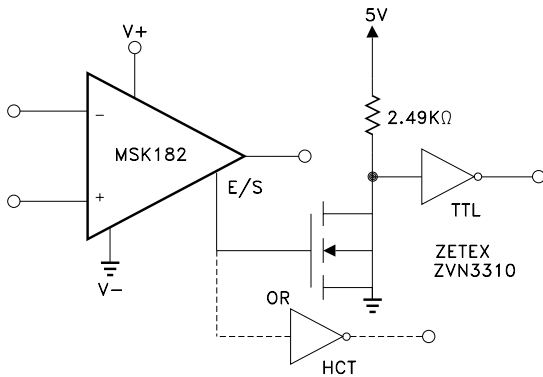
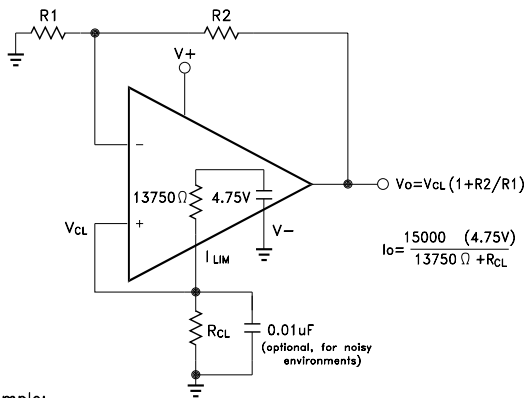

Figure 3

Thermal Shutdown Status With a Single Supply



For Example:

If $I_{LIM} = 3A$, $R_{CL} = 10K\Omega$

$$V_{CL} = \frac{10K\Omega \cdot 4.75V}{(10K\Omega + 13750\Omega)} = 2V$$

Desired $V_o = 20V$, $G = \frac{20}{2} = 10$

$R_1 = 1K\Omega$ and $R_2 = 9K\Omega$

Figure 5 Voltage Source

Uses voltage developed at I_{LIM} pin as a moderately accurate reference voltage.

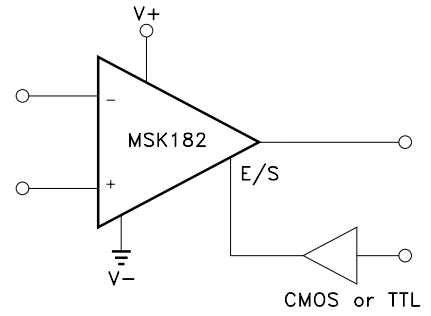

Figure 2 Output Disable with a Single Supply

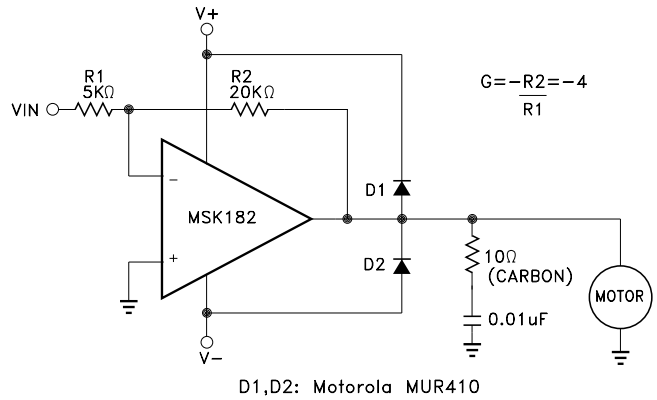

Figure 4 Motor Drive Circuit

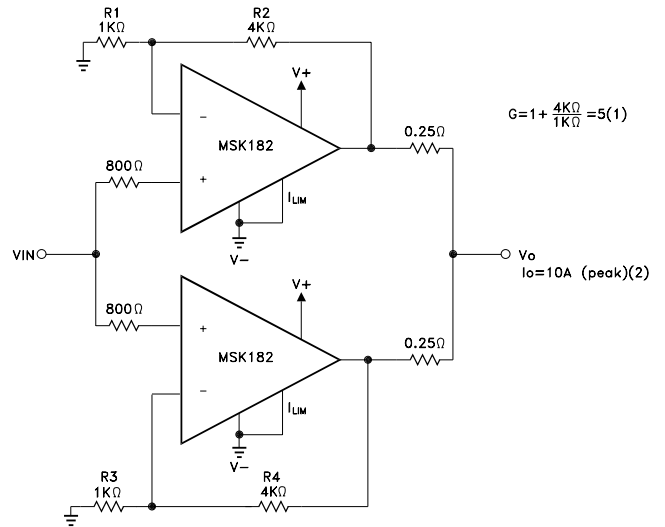
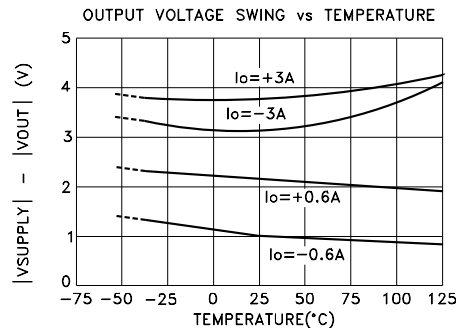
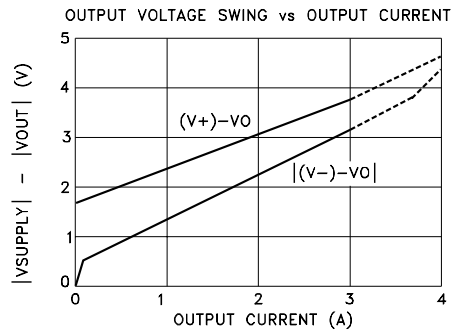
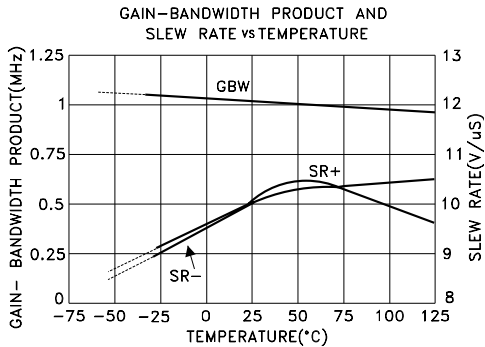
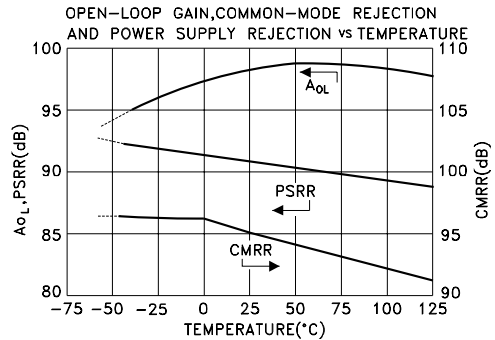
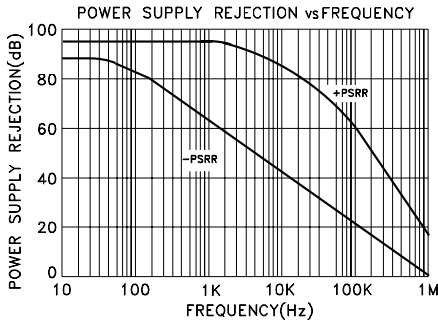
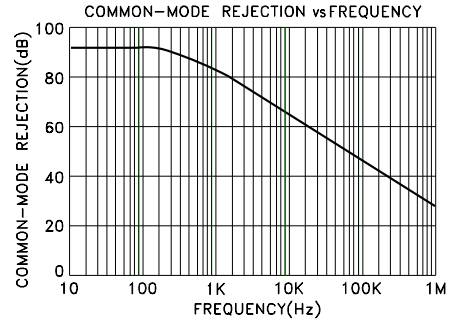
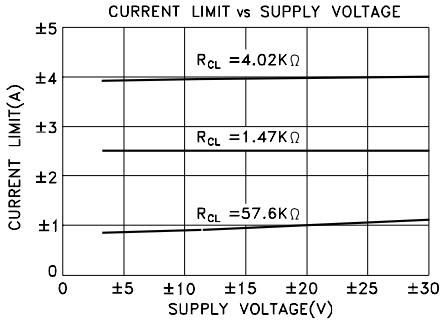
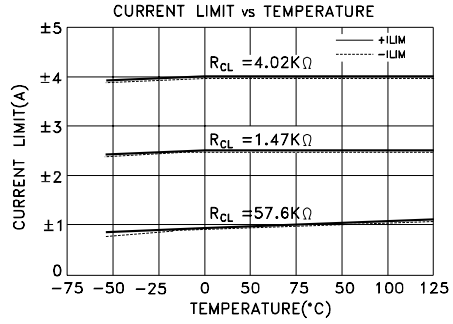
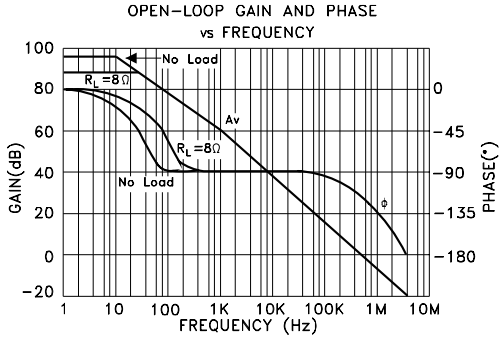
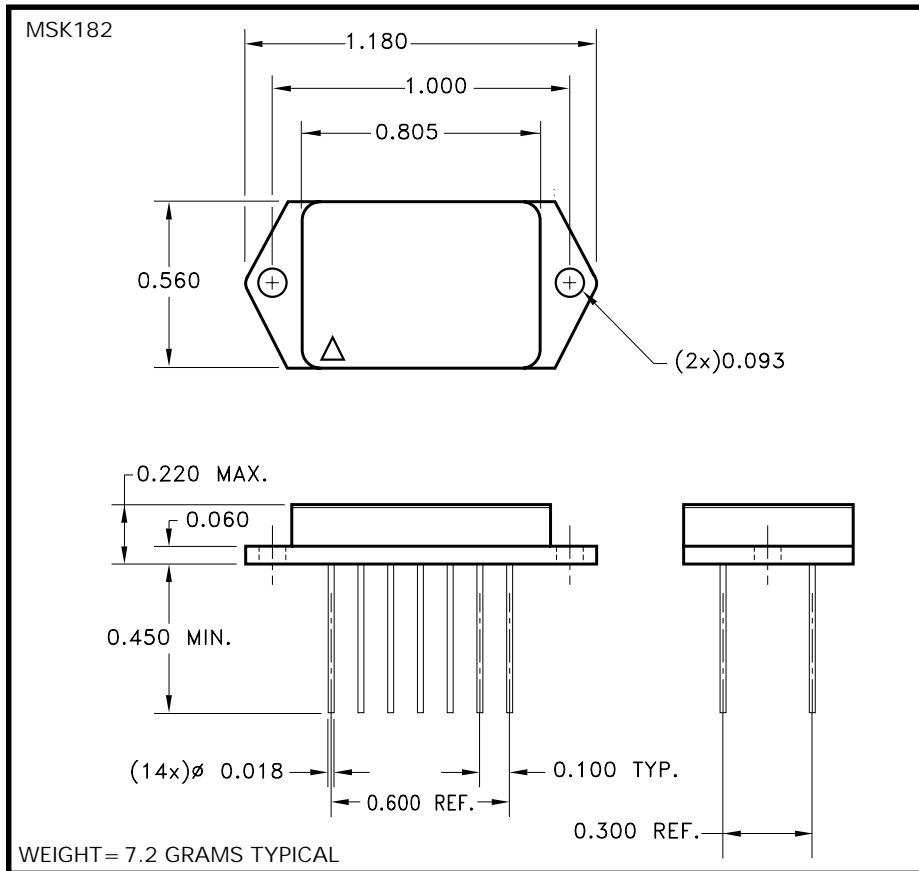

Figure 6 Parallel Output For Increased Output Current

TYPICAL PERFORMANCE CURVES



MECHANICAL SPECIFICATIONS



ESD TRIANGLE INDICATES PIN 1.
 ALL DIMENSIONS ARE ± 0.010 INCHES UNLESS OTHERWISE LABELED.

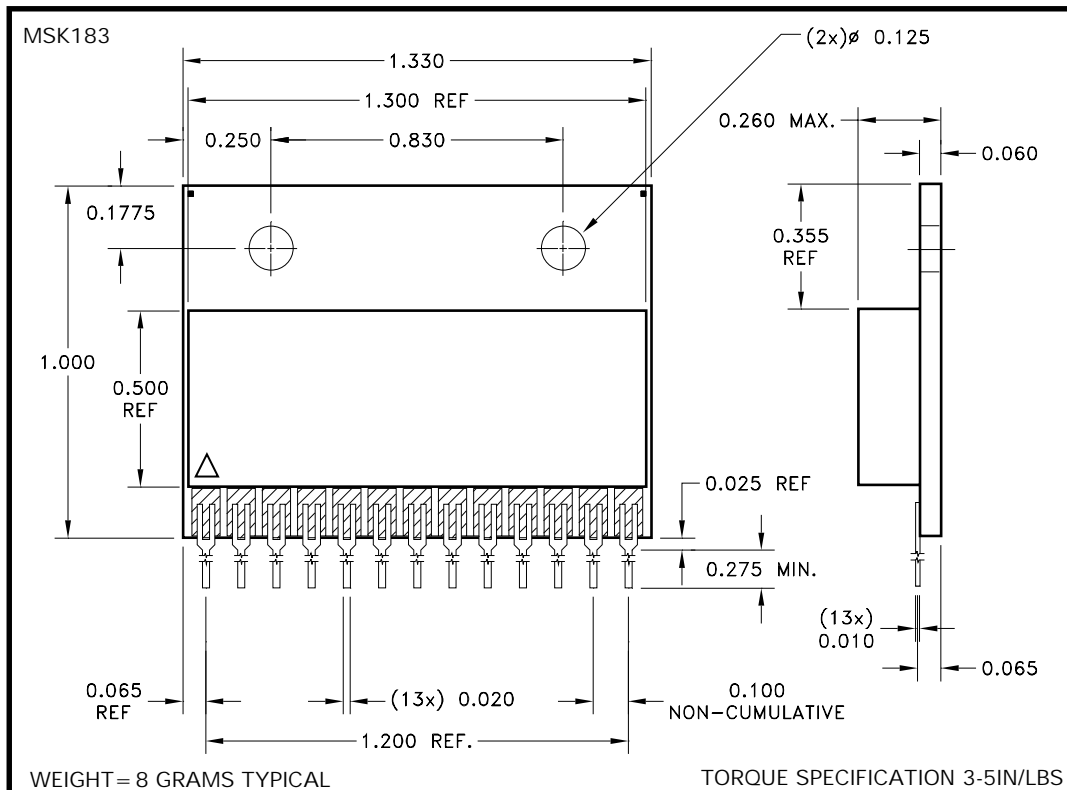

ESD TRIANGLE INDICATES PIN 1.
 ALL DIMENSIONS ARE ± 0.010 INCHES UNLESS OTHERWISE LABELED.

MECHANICAL SPECIFICATIONS CONTINUED

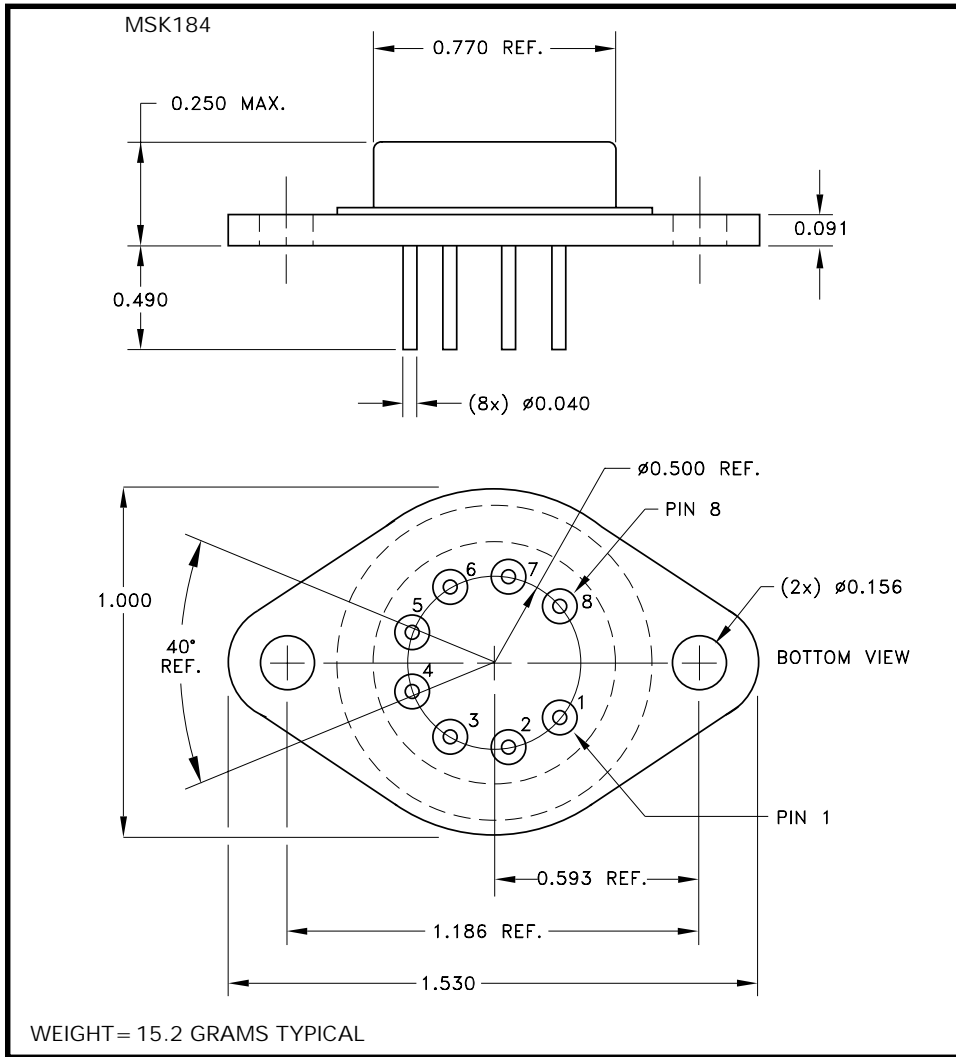

ESD TRIANGLE INDICATES PIN 1.
 ALL DIMENSIONS ARE ± 0.010 INCHES UNLESS OTHERWISE LABELED.

ORDERING INFORMATION

MSK 182 G

SCREENING

BLANK = INDUSTRIAL; E = EXTENDED RELIABILITY

G = MIL-PRF-38534/DSCC SMD 5962-92152 (REDUCED TEMP RANGE)

GENERAL PART NUMBER (MSK182,183 or 184)

NOTE: THE MSK 183 IS NOT AVAILABLE WITH E OR G SUFFIX.

M.S. Kennedy Corp.

4707 Dey Road, Liverpool, New York 13088

Phone (315) 701-6751

FAX (315) 701-6752

www.mskennedy.com

The information contained herein is believed to be accurate at the time of printing. MSK reserves the right to make changes to its products or specifications without notice, however, and assumes no liability for the use of its products. Please visit our website for the most recent revision of this datasheet.

Contact MSK for MIL-PRF-38534 qualification status.