

# Graphic Monitor On-Screen Display - 24 CMOS

This is a high performance HCMOS device designed to interface with a micro controller unit to allow colored symbols or characters to be displayed onto CRT monitor. Because of the large number of fonts, 256 fonts including 240 standard fonts and 16 multi-color fonts, GMOSD-24 is suitable to be adopted for the multi-language monitor application especially. Its on-chip PLL allows both multiscan operation and self generation of system timing. It also minimizes the MCU's burden through its built-in RAM. By storing a full screen of data and control information, this device has a capability to carry out 'screen-refresh' without any MCU supervision.

Since there is no clearance between characters, special graphics oriented characters can be generated by combining two or more character blocks. There are two kinds of resolutions that users can choose. By changing the number of dots per horizontal line to 384 (CGA) or 768 (SVGA), smaller characters with higher resolution can be easily achieved. The full OSD menu is formed of 15 rows x 30 columns which can be freely positioned on anywhere of the monitor screen by changing vertical or horizontal delay.

There are 8 PWM DAC channels for external digital to analog control. Each PWM DAC channel is composed of an 8 bit register which contains a 5 bit PWM in MSB portion and a 3 bit binary rate multiplier (BRM) in LSB portion.

Special functions such as character background color, blinking, bordering or shadowing, four-level windows with programmable shadowing, row double height and double width, programmable vertical height of character and row-to-row spacing, and full-screen erasing and Fade-In/Fade-Out are also incorporated. There are 8 color selections for any individual character display with row intensity attribute and window intensity attribute to expand the color mixture on OSD menu.

- 8 Channels 8-bit Synchronous PWM DAC with Push-Pull Output
- Totally 256 Fonts Including 240 Standard Fonts and 16 Multi-Color Fonts.
- Two Resolutions: 384 (CGA) or 768 (SVGA) Dots/Line
- Wide Operating Frequency Range for High End Monitor: 15KHz ~ 120KHz
- Fully Programmable Character Array of 15 Rows by 30 Columns
- 8-Color Selection for Characters with Color Intensity Attribute on Each Row
- 7-Color Selection for Characters background
- True 16-Color Selection for Windows
- Fancy Fade-In/Fade-Out Effects
- Programmable Height of Character to Meet Multi-Sync Requirement
- Row To Row Spacing Control to Avoid Expansion Distortion
- Four Programmable Windows with Overlapping Capability
- Shadowing on Windows with Programmable Shadow Width/Height
- Character Bordering or Shadowing
- Character/Symbol Blinking Function
- Programmable Vertical and Horizontal Positioning for Display Centre
- Double Character Height and Double Character Width
- Internal PLL Generates a Wide-Ranged System Clock (92.2 MHz)
- M\_BUS (IIC) Interface with Address \$7A (SPI Bus is Mask Option)

## MC141542P2

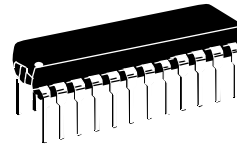

**P SUFFIX**  
 PLASTIC PACKAGE

### ORDERING INFORMATION

MC141542P2 Plastic Dip

### PIN ASSIGNMENT

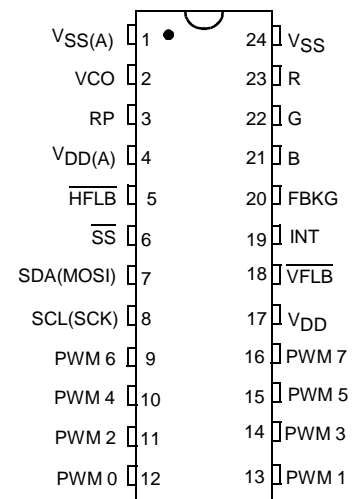

**BLOCK DIAGRAM**

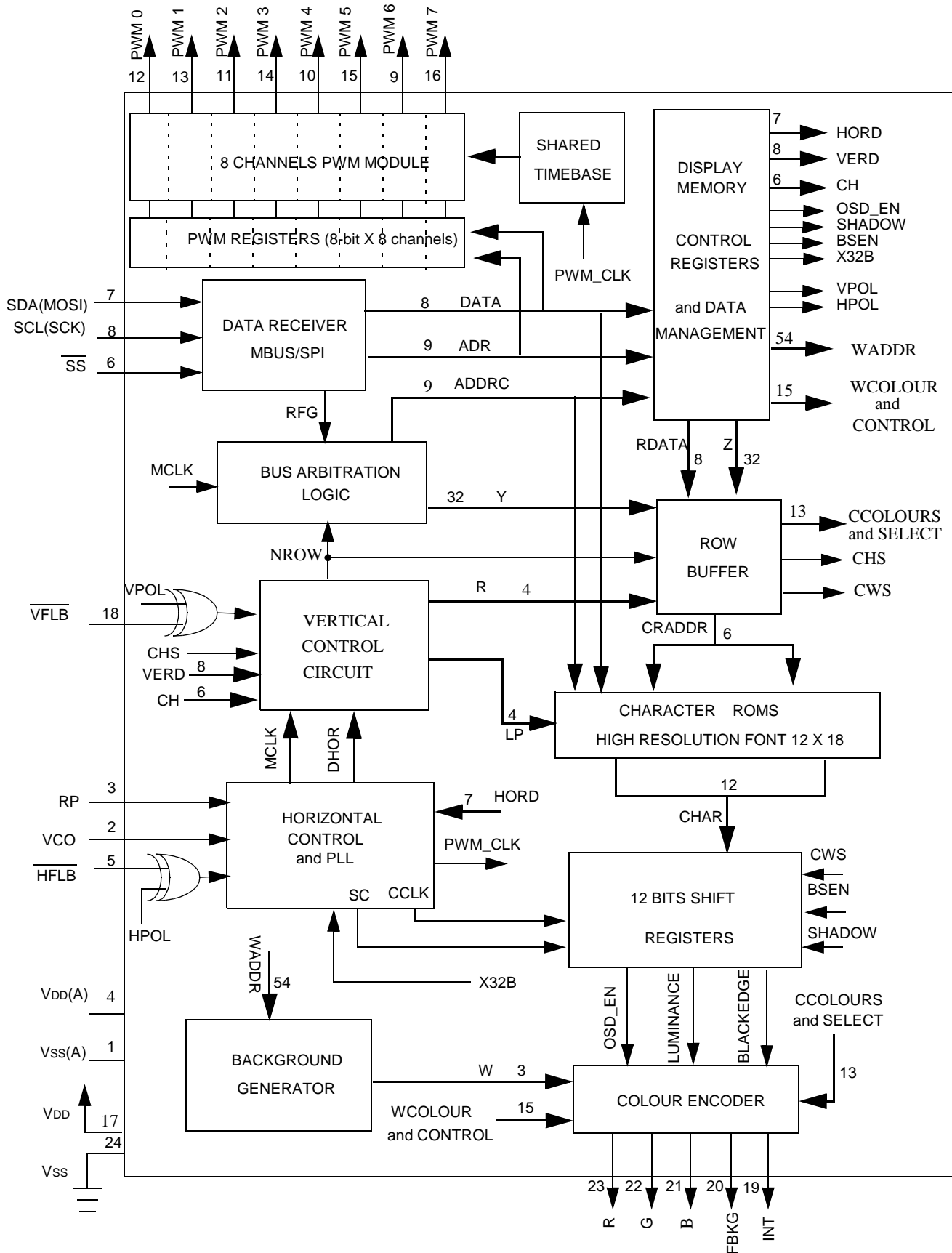

**ABSOLUTE MAXIMUM RATINGS** Voltage Referenced to V<sub>SS</sub>

Symbol	Characteristic	Value	Unit
V <sub>DD</sub>	Supply Voltage	- 0.3 to + 7.0	V
V <sub>in</sub>	Input Voltage	V <sub>SS</sub> - 0.3 to V <sub>DD</sub> + 0.3	V
I <sub>d</sub>	Current Drain per Pin Excluding V <sub>DD</sub> and V <sub>SS</sub>	25	mA
T <sub>a</sub>	Operating Temperature Range	0 to 85	°C
T <sub>stg</sub>	Storage Temperature Range	- 65 to + 150	°C

NOTE: Maximum Ratings are those values beyond which damage to the device may occur. Functional operation should be restricted to the limits in the Electrical Characteristics tables or Pin Description section.

This device contains protection circuitry to guard against damage due to high static voltages or electric fields. However, precautions must be taken to avoid applications of any voltage higher than maximum rated voltages to this high-impedance circuit. For proper operation, V<sub>in</sub> and V<sub>out</sub> should be constrained to the range V<sub>SS</sub> ≤ (V<sub>in</sub> or V<sub>out</sub>) ≤ V<sub>DD</sub>.

Unused inputs must always be tied to an appropriate logic voltage level (e.g., either V<sub>SS</sub> or V<sub>DD</sub>). Unused outputs must be left open.

**AC ELECTRICAL CHARACTERISTICS** (V<sub>DD</sub>/V<sub>DD(A)</sub> = 5.0 V, V<sub>SS</sub>/V<sub>SS(A)</sub> = 0 V, T<sub>A</sub> = 25°C, Voltage Referenced to V<sub>SS</sub>)

Symbol	Characteristic	Min	Typ	Max	Unit
t <sub>r</sub> t <sub>f</sub>	Output Signal (R, G, B, FBKG and INT) C <sub>load</sub> = 30 pF	—	—	6	ns
	Rise Time Fall Time				
t <sub>r</sub> t <sub>f</sub>	Output Signal (PWM0 - PWM7) C <sub>load</sub> = 30 pF	—	—	20	ns
	Rise Time Fall Time				
F <sub>HFLB</sub>	HFLB Input Frequency	15K	—	120K	Hz

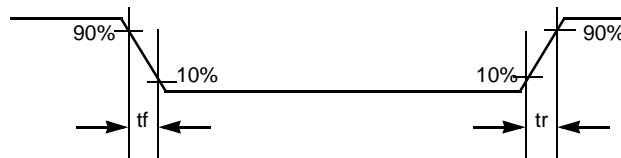

**Figure 1. Switching Characteristics**

**DC CHARACTERISTICS**  $V_{DD}/V_{DD(A)} = 5.0\text{ V} \pm 10\%$ ,  $V_{SS}/V_{SS(A)} = 0\text{ V}$ ,  $T_A = 25^\circ\text{C}$ , Voltage Referenced to  $V_{SS}$

Symbol	Characteristic	Min	Typ	Max	Unit
$V_{OH}$	High Level Output Voltage $I_{out} = -5\text{ mA}$	$V_{DD} - 0.8$	—	—	V
$V_{OL}$	Low Level Output Voltage $I_{out} = 5\text{ mA}$	—	—	$V_{SS} + 0.4$	V
$V_{IL}$ $V_{IH}$	Digital Input Voltage (Not Including SDA and SCL) Logic Low Logic High	— $0.7 V_{DD}$	— —	$0.3 V_{DD}$ —	V V
$V_{IL}$ $V_{IH}$	Input Voltage of Pin SDA and SCL in SPI Mode Logic Low Logic High	— $0.7 V_{DD}$	— —	$0.3 V_{DD}$ —	V V
$V_{IL}$ $V_{IH}$	Input Voltage of Pin SDA and SCL in M_BUS Mode Logic Low Logic High	— $0.7 V_{DD}$	— —	$0.3 V_{DD}$ —	V V
$I_{II}$	High-Z Leakage Current (R, G, B and FBKG)	- 10	—	+ 10	$\mu\text{A}$
$I_{II}$	Input Current (Not Including RP, VCO, R, G, B, FBKG and INT)	- 10	—	+ 10	$\mu\text{A}$
$I_{DD}$	Supply Current (No Load on Any Output) at $V_{DD}=5.0\text{V}$	—	—	+ 26	mA
LVI	Low Voltage Inhibit for PWM DAC output	2.7	3.2	3.6	V

## PIN DESCRIPTION

### VSS(A) (Pin 1)

This pin provides the signal ground to the PLL circuitry. Analog ground for PLL is separated from digital ground for optimal performance.

### VCO (Pin 2)

A dc control voltage input to regulate an internal oscillator frequency. See the Application Diagram for the application values used.

### RP (Pin 3)

An external RC network is used to bias an internal VCO to resonate at the specific dot frequency. The maximum voltage at Pin 3 should not exceed 3.5 V at any condition. See the Application Diagram for the application values used.

### VDD(A) (Pin 4)

A positive 5 V dc supply for PLL circuitry. Analog power for PLL is separated from digital power for optimal performance.

### HFLB (Pin 5)

This pin inputs a negative polarity horizontal synchronize signal pulse to phase lock into an internal system clock generated by the on-chip VCO circuit.

### SS (Pin 6)

This input pin is part of the SPI system. An active low signal generated by the master device enables this slave device to accept data. Pull high to terminate the SPI communication. If M\_BUS is employed as the serial interface, this pin should be tied to either  $V_{DD}$  or  $V_{SS}$ .

### VDD (Pin 17)

### SDA (MOSI) (Pin 7)

Data and control message are being transmitted to this chip from a host MCU, via one of the two serial bus systems. With either protocol, this wire is configured as a uni-directional data line. (Detailed description of these two protocols will be discussed in the M\_BUS and SPI sections).

### SCL (SCK) (Pin 8)

A separate synchronizing clock input from the transmitter is required for either protocol. Data is read at the rising edge of each clock signal.

### PWM 6 (Pin 9)

Channel 6 of the PWM.

### PWM 4 (Pin 10)

Channel 4 of the PWM.

### PWM 2 (Pin 11)

Channel 2 of the PWM.

### PWM 0 (Pin 12)

Channel 0 of the PWM.

### PWM 1 (Pin 13)

Channel 1 of the PWM.

### PWM 3 (Pin 14)

Channel 3 of the PWM.

### PWM 5 (Pin 15)

Channel 5 of the PWM.

### PWM 7 (Pin 16)

Channel 7 of the PWM.

This is the power pin for the digital logic of the chip.

### VFLB (Pin 18)

Similar to Pin 5, this pin inputs a negative polarity of vertical synchronize signal to synchronize the vertical control circuit.

### INT (Pin 19)

This output pin is used to indicate the color intensity. If the intensity control bits are set in the row attribute registers or window control registers, this pin will output a logic high while displaying the specified windows or the characters on the associated rows. Otherwise, it will keep in low state. Please refer to Figure 15 for detail timing chart. Thus, 16-color selection is achievable by combining this intensity pin with R/G/B outputs. On the other hand, this color intensity information could be reflected on the R/G/B pins by asserting tri-state instead of logic high if 3\_S bit is set to 1. Refer to the "REGISTERS" for more information.

### FBKG (Pin 20)

This pin will output a logic high while displaying characters or windows when FBKGC bit in frame control register is 0, and output a logic high only while displaying characters when FBKGC bit is 1. It is defaulted to high impedance state after power on, or when there is no output. An external 10 kΩ resistor pulled low is recommended to avoid level toggling caused by hand effect when there is no output.

### B,G,R (Pin 21, 22, 23)

GMOSD-24 color outputs in TTL level to the host monitor. These three signals are open drain outputs if 3\_STATE bit is set and the color intensity is inactive. Otherwise, they are active high push-pull outputs. See "REGISTERS" for more information. These pins are in high impedance state after power on.

### VSS (Pin 24)

This is the ground pin for the digital logic of the chip.

## SYSTEM DESCRIPTION

MC141542P2 is a full screen memory architecture. Refresh is done by the built-in circuitry after a screenful of display data has been loaded in through the serial bus. Only changes to the display data need to be input afterward.

Serial data, which includes screen mapping address, display information, and control messages, are being transmitted via one of the two serial buses: M\_BUS or SPI (mask option). These two sets of buses are multiplexed onto a single set of wires. Standard parts offer M\_BUS transmission.

Data is first received and saved in the MEMORY MANAGEMENT CIRCUIT in the Block Diagram. Meanwhile, the GMOSD-24 is continuously retrieving the data and putting it into a ROW BUFFER for display and refreshing, row after row. During this storing and retrieving cycle, a BUS ARBITRATION LOGIC will patrol the internal traffic, to make sure that no crashes occur between the slower serial bus receiver and fast 'screen-refresh' circuitry. After the full screen display data is received through one of the serial communication interface, the link can be terminated if change on display is not required.

The bottom half of the Block Diagram constitutes the heart of this entire system. It performs all the GMOSD-24 functions such as programmable vertical length (from 16 lines to 63

lines), display clock generation (which is phase locked to the incoming horizontal sync signal at Pin 5 HFLB), bordering or shadowing, and multiple windowing.

## COMMUNICATION PROTOCOLS

### BUS Operation

The operating clock for M\_Bus or SPI bus derives from system dot clock. Internal PLL is using to generate the dot clock base on the HFLB input frequency where the dot clock is equal to  $384/768 \times \text{HFLB}$  in 384/768 modes respectively. In order to have stable operation of M\_Bus or SPI bus in the OSD and meet below specifications, HFLB(15k-120k) must be presented and the PLL locks to HFLB properly. Refer to Application Diagram for PLL bias circuit.

### M\_BUS Serial Communication

This is a two-wire serial communication link that is fully compatible with the IIC bus system. It consists of SDA bidirectional data line and SCL clock input line. Data is sent from a transmitter (master), to a receiver (slave) via the SDA line, and is synchronized with a transmitter clock on the SCL line at the receiving end. The maximum data rate is limited to 100 kbps. The default chip address is \$7A. Please refer to the IIC-Bus specification for detail timing requirement.

### Operating Procedure

Figure 2 shows the M\_BUS transmission format. The master initiates a transmission routine by generating a START condition, followed by a slave address byte. Once the address is properly identified, the slave will respond with an ACKNOWLEDGE signal by pulling the SDA line LOW during the ninth SCL clock. Each data byte which then follows must be eight bits long, plus the ACKNOWLEDGE bit, to make up nine bits together. Appropriate row and column address information and display data can be downloaded sequentially in one of the three transmission formats described in DATA TRANSMISSION FORMATS SECTION. In the cases of no ACKNOWLEDGE or completion of data transfer, the master will generate a STOP condition to terminate the transmission routine. Note that the OSD\_EN bit must be set after all the display information has been sent in order to activate the GMOSD-24 circuitry of MC141542P2, so that the received information can then be displayed.

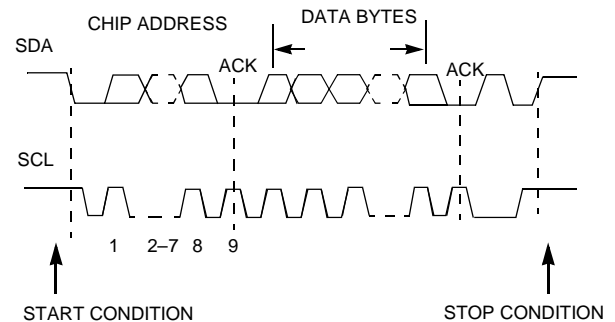

Figure 2. M\_BUS Format

### Serial Peripheral Interface (SPI)

Similar to M\_BUS communication, SPI requires separate clock (SCK) and data (MOSI) lines. In addition, a SS SLAVE



- (a) R -> C -> I -> R -> C -> I -> . . . . .
- (b) R -> C -> I -> C -> I -> C -> I . . . . .
- (c) R -> C -> I -> I -> I -> . . -> I<sub>row attr.</sub> -> I<sub>dummy</sub> -> I -> I . . . . .

NOTE: - R means row byte.

- C means column byte.

- I means data byte.

- In format (c), one dummy data byte(col 31) has to be inserted after the row attribute data byte (col 30) at end of each row, before the first character attribute data byte of the next row.

To differentiate the row address for attribute/control registers from display area when transferring data, the most significant three bits are set to '101' to represent the row address of the attribute/control registers, while '00X' for column address used in format (a) or (b) and '01X' for column address used in format (c). There is some limitation on using mix-formats during a single transmission. It is permissible to change the format from (a) to (b), or from (a) to (c), or from (b) to (a), but not from (c) back to (a) or (b).

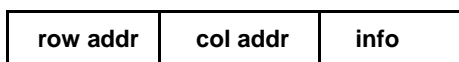
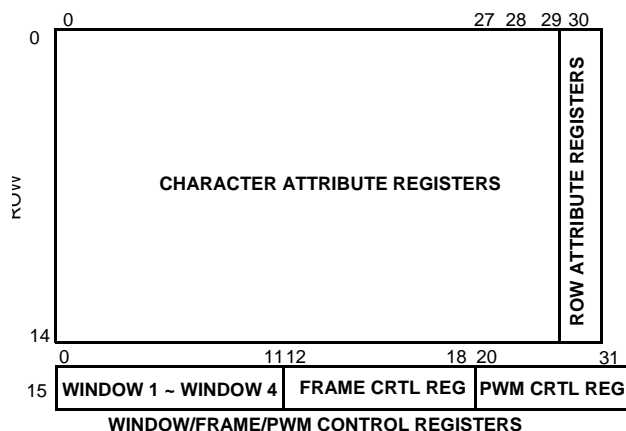

Figure 6. Data Packet for Attribute/Control Data



ADDRESS	BIT								FORMAT
	7	6	5	4	3	2	1	0	
ROW	1	0	1	X	D	D	D	D	a, b, c
COLUMN	0	0	X	D	D	D	D	D	a, b
COLUMN	0	1	X	D	D	D	D	D	c

X: don't care

D: valid data

Figure 7. Address Bit Patterns for Attribute/Control Data

## MEMORY MANAGEMENT

All the internal programmable area can be divided into two parts including (1) Display Registers (2) Attribute/Control Registers. Please refer to the following two figures for the corresponding memory map.

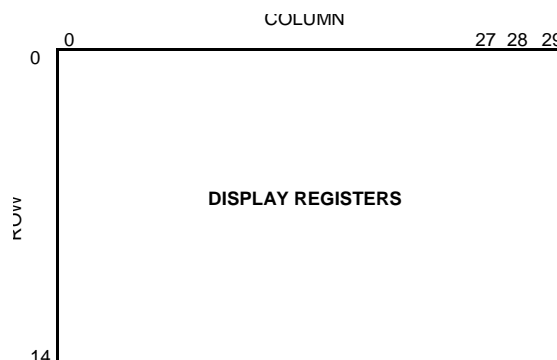

Figure 8. Memory Map of Display Registers

Internal display RAM are addressed with row and column (coln) number in sequence. As the display area is 15 rows by 30 columns, the related display registers are also 15 by 30. The space between row 0 and coln 0 to row 14 and coln 29 are called Display registers, with each contains a character/symbol address corresponding to display location on monitor screen. And each register is 8-bit wide to identify the selected character/symbol out of 256 ROM fonts.

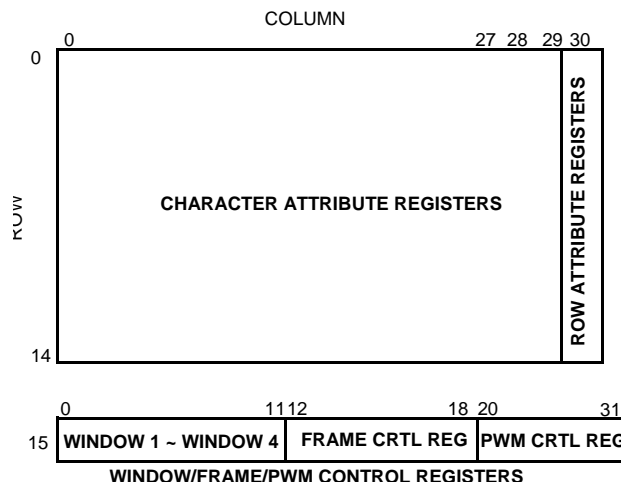

Figure 9. Memory Map of Attribute/Control Registers

Besides the font selection, there is 3-bit attribute associated with each symbol to identify its color and 3-bit to define its background. Because of 3-bit attribute, each character can select any color out of 8 independently on the same row, as well as background. Every data row associate with one attribute register, which locate at coln 30 of their respective rows, to control the characters display format of that row such as the character blinking, color intensity, character double height and character double width function. In addition, other control registers are located at row 15 such as window control, frame function control and PWM registers. Four window control registers for each of four windows together with four frame control registers and twelve PWM registers occupy the first 28 columns of row 15 space. These control registers will be described on the "REGISTERS" section.

User should handle the internal display RAM address location with care especially for those rows with double length alphanumeric symbols. For example, if row n is destined to be double height on the memory map, the data displayed on screen row n and n+1 will be represented by the data contained in the memory address of row n only. The data of next row n+1 on the memory map will appear on the screen of n+2 and n+3 row space and so on. Hence, it is not necessary to throw in a row of blank data to compensate for the double row action. User needs to take care of excessive row of data in memory in order to avoid over running the limited number of row space on the screen.

There is difference for rows with double width alphanumeric symbols. Only the data contained in the even numbered columns of memory map will be shown, the odd numbered columns will be ignored and not disclosed.

## REGISTERS

### (I) Display Register

Display Register (Row 0~14, Coln 0~29)

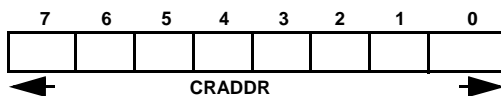

Bit 7-0 CRADDR - This eight bits address one of the 256 characters or symbols resided in the character ROM fonts.

### (II) Attribute/Window/Control/Frame Registers

Character Attribute Register (Row 0~14, Coln 0~29)

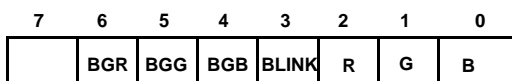

Bit 6-4 These three bits define the color of the background for the correspondent characters. If all three bits are clear, no background will be shown(transparent). Therefore, total seven background colors can be selected.

Bit 3 BLINK - The blinking effect will be active on the corresponding character if this bit is set to 1. The blinking frequency is approximately one time per second (1Hz) with fifty-fifty duty cycle at 80Hz vertical scan frequency.

Bit 2-0 These three bits are the color attribute to define the color of the associated character/symbol.

Table 1. The Character/Window Color Selection

	R	G	B
<b>Black</b>	0	0	0
<b>Blue</b>	0	0	1
<b>Green</b>	0	1	0
<b>Cyan</b>	0	1	1
<b>Red</b>	1	0	0
<b>Magenta</b>	1	0	1
<b>Yellow</b>	1	1	0
<b>White</b>	1	1	1

Row Attribute Register (Row 0~14, Coln 30)

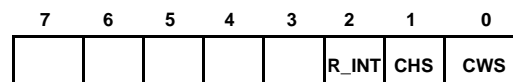

Bit 2 R\_INT - Row intensity bit controls the color intensity of the displayed character/symbol on the corresponding row. Setting this bit to 1 means high intensity color and the INT pin will go high while displaying the characters of this row.

Bit 1 CHS - It determines the height of a display symbol. When this bit is set, the symbol is displayed in double height.

Bit 0 CWS - Similar to bit 1, character is displayed in double width, if this bit is set.

### Window 1 Registers

Row 15 Coln 0

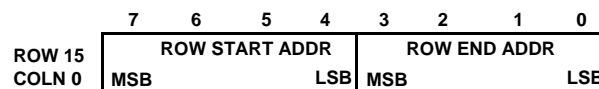

Row 15 Coln 1

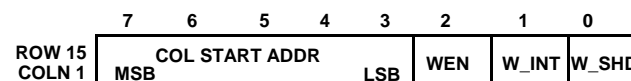

Bit 2 WEN - It enables the window 1 generation if this bit is set.

Bit 1 W\_INT - This additional color related bit provides the color intensity selection for window 1. If this bit is 0, INT pin will go low while displaying window 1. The default value is 1 to indicate high intensity. Video pre-amplifier or external R/G/B switch can make use of INT pin for windows's color intensity control.



Bit 0 W\_SHD - Shadowing on window. Set this bit to activate the window 1 shadowing. When the window is active, the right M pixels and lower N horizontal scan lines will output black shadowing. The width/height of window shadow, number of M/N, is defined in the frame control registers located at row 15 column 16 and 17. See the following figure and the related frame control register for detail.

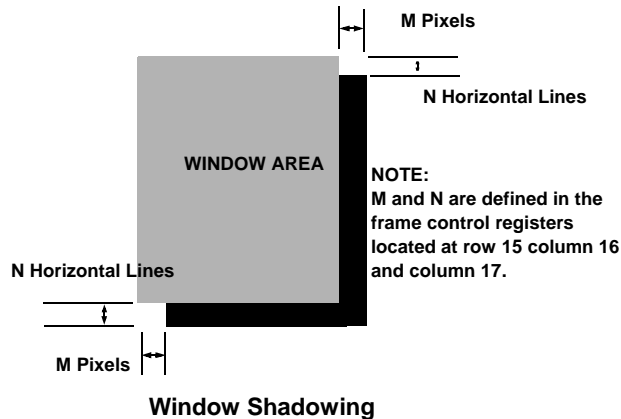

**Row 15 Coln 2**

	7	6	5	4	3	2	1	0
ROW 15 COLN 2	COL END ADDR			LSB		R	G	B
	MSB							

Bit 2-0 R, G and B - Controls the color of window 1. Refer to Table 1 for color selection. Window 1 registers occupy Column 0-2 of Row 15, Window 2 from Column 3-5, Window 3 from 6-8 and Window 4 from 9-11. Window 1 has the highest priority, and Window 4 the least. If window over-lapping occurs, the higher priority window will cover the lower one, and the higher priority color will take over on the overlap window area. If the start address is greater than the end address, this window will not be displayed.

**Window 2 Registers**

**Row 15 Coln 3**

	7	6	5	4	3	2	1	0
ROW 15 COLN 3	ROW START ADDR			ROW END ADDR				
	MSB		LSB	MSB				LSB

**Row 15 Coln 4**

	7	6	5	4	3	2	1	0
ROW 15 COLN 4	COL START ADDR			LSB		WEN	W_INT	W_SHD
	MSB							

Bit 2 WEN - It enables the window 2 generation if this bit is set.

Bit 1 W\_INT - This additional color related bit provides the color intensity selection for window 2. If this bit is 0, INT pin will go low while displaying window 2. The default value is

1 to indicate high intensity. Video pre-amplifier or external R/G/B switch can make use of INT pin for windows's color intensity control.

Bit 0 W\_SHD - Shadowing on window. Set this bit to activate the window 2 shadowing.

**Row 15 Coln 5**

	7	6	5	4	3	2	1	0
ROW 15 COLN 5	COL END ADDR			LSB		R	G	B
	MSB							

Bit 2-0 R, G and B - Controls the color of window 2. Refer to Table 1 for color selection. Window 1 registers occupy Column 0-2 of Row 15, Window 2 from Column 3-5, Window 3 from 6-8 and Window 4 from 9-11. Window 1 has the highest priority, and Window 4 the least. If window over-lapping occurs, the higher priority window will cover the lower one, and the higher priority color will take over on the overlap window area. If the start address is greater than the end address, this window will not be displayed.

**Window 3 Registers**

**Row 15 Coln 6**

	7	6	5	4	3	2	1	0
ROW 15 COLN 6	ROW START ADDR			ROW END ADDR				
	MSB		LSB	MSB				LSB

**Row 15 Coln 7**

	7	6	5	4	3	2	1	0
ROW 15 COLN 7	COL START ADDR			LSB		WEN	W_INT	W_SHD
	MSB							

Bit 2 WEN - It enables the window 3 generation if this bit is set.

Bit 1 W\_INT - This additional color related bit provides the color intensity selection for window 3. If this bit is 0, INT pin will go low while displaying window 3. The default value is 1 to indicate high intensity. Video pre-amplifier or external R/G/B switch can make use of INT pin for windows's color intensity control.

Bit 0 W\_SHD - Shadowing on window. Set this bit to activate the window 3 shadowing.

**Row 15 Coln 8**

	7	6	5	4	3	2	1	0
ROW 15 COLN 8	COL END ADDR			LSB		R	G	B
	MSB							

Bit 2-0 R, G and B - Controls the color of window 3. Refer to Table 1 for color selection. Window 1 registers occupy Column 0-2 of Row 15, Window 2 from Column 3-5, Window 3 from 6-8 and Window 4 from 9-11. Window 1 has the highest priority, and Window 4 the least. If window over-lapping occurs, the higher priority window will cover the lower one, and the higher priority color will take over on the overlap window area. If the start address is greater than the end address, this window will not be displayed.

**Window 4 Registers**

**Row 15 Coln 9**

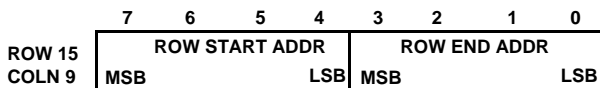

**Row 15 Coln 10**

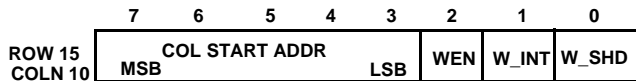

Bit 2 WEN - It enables the window 4 generation if this bit is set.

Bit 1 W\_INT - This additional color related bit provides the color intensity selection for window 4. If this bit is 0, INT pin will go low while displaying window 4. The default value is 1 to indicate high intensity. Video pre-amplifier or external R/G/B switch can make use of INT pin for windows's color intensity control.

Bit 0 W\_SHD - Shadowing on window. Set this bit to activate the window 4 shadowing.

**Row 15 Coln 11**

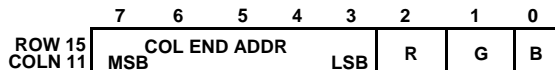

Bit 2-0 R, G and B - Controls the color of window 4. Refer to Table 1 for color selection. Window 1 registers occupy Column 0-2 of Row 15, Window 2 from Column 3-5, Window 3 from 6-8 and Window 4 from 9-11. Window 1 has the highest priority, and Window 4 the least. If window over-lapping occurs, the higher priority window will cover the lower one, and the higher priority color will take over on the overlap window area. If the start address is greater than the end address, this window will not be displayed.

**Vertical Delay Control Register Row 15 Coln 12**

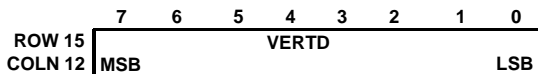

Bit 7-0 VERTD - These 8 bits define the vertical starting position. Total 256 steps, with an increment of four horizontal lines per step for each field. Its value can't be zero anytime. The default value of it is 4.

**Horizontal Delay Control Register Row 15 Coln 13**

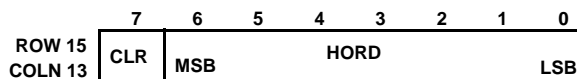

Bit 7 CLR - Setting this bit to 1 clear all display register from Row 0 to Row 14; Control register will not be erased.

Bit 6-0 HORD - Horizontal starting position for character display. 7 bits give a total of 128 steps and each increment represents five dots movement shift to the right on the monitor screen. Its value cannot be zero anytime. The default value of it is 15.

**Character Height Control Register Row 15 Coln 14**

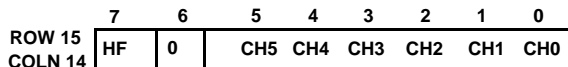

Bit 7 HF - High Frequency Bit. If the incoming H sync signal is higher than 60 KHz, set this bit to 1 for better performance. This bit controls gain of internal VCO so that PLL can work for whole range from 15KHz to 120KHz.

Bit 6 Bit reserved. Set to 0 for normal operation.

Bit 5-0 CH5-CH0 - This six bits will determine the displayed character height. GMOSD adopts 12 by 18 font matrix and the middle 16 lines, line 2 to line 17, are expanded by BRM algorithm. The top line and bottom line will be duplicated dependent on the value of CH. No any line is duplicated for top and bottom if CH is less than 32. One extra duplicated line will be inserted for top and bottom if CH is larger or equal to 32 and less than 48. Two extra duplicated lines will be inserted for top and bottom if CH is larger or equal to 48. Setting a value below 16 will not have a predictable result. Display character line number is equal to C1 x (18 + C2) where C1 = 1, 2 or 3 defined by CH5-CH4 and C2 = 0-15 defined by CH3-CH0 (BRM).

	7	6	5	4	3	2	1	0
ROW 15 COLN 15	OSD_EN	BSEN	SHADOW		X32B	3_S	FAN	FBKGC

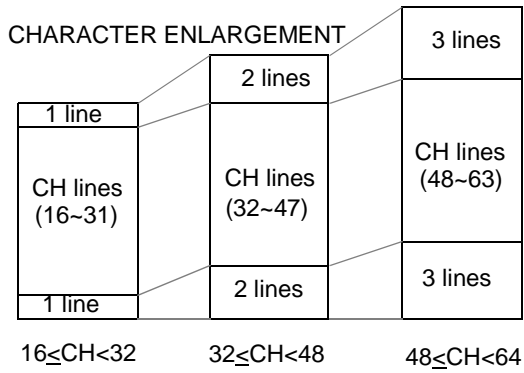

Bit 7 OSD\_EN - OSD circuit is activated when this bit is set.

Bit 6 BSEN - It enables the character bordering or shadowing function when this bit is set.

Bit 5 SHADOW - Character with black-edge shadowing is selected if this bit is set, otherwise bordering prevails.

Bit 3 X32B - It determines the number of dots per horizontal line. There are 384 dots per horizontal line if bit X32B is clear and this is also the default power on state. Otherwise, 768 dots per horizontal sync line when bit X32B is set to 1. Please refer to the Table 2 for details.

Table 2. Resolution Setting

X32B	0	1
Dots / Line	384	768
Resolution	CGA	SVGA

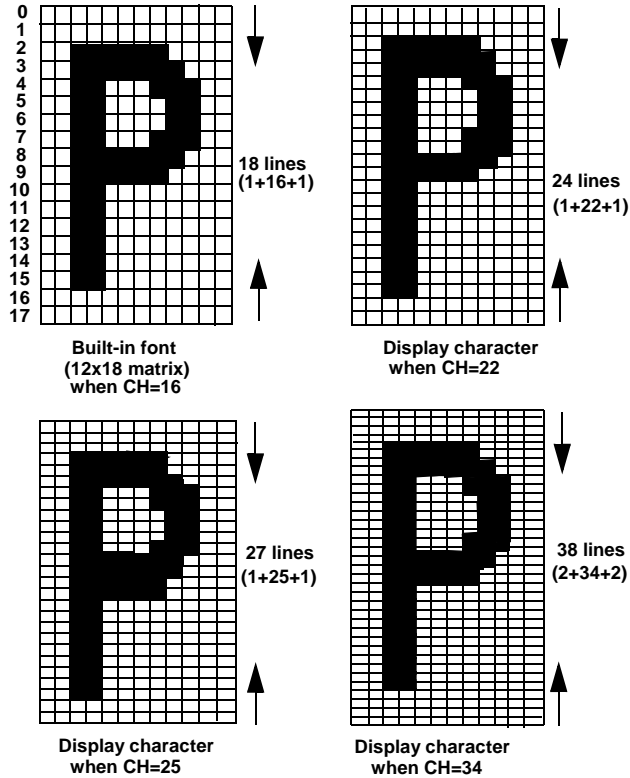

Figure 10. Variable Character Height

Figure 10 illustrates the enlargement algorithm for top and bottom lines and how this chip expand the built-in character font to the desired height.

In this approach, the actual character height in unit of the scan line can be calculated from the following simple equation:

$$H = CH + N$$

Where H is the expanded character height in unit of lines

CH is the number defined by CH5 ~ CH0

N is a variable dependent on the value of CH

N = 2 when  $16 \leq CH < 32$

N = 4 when  $32 \leq CH < 48$

N = 6 when  $48 \leq CH < 64$

Bit 2 3\_S - By setting this bit to 1, R/G/B could output high impedance state if the intensity attribute of characters or windows is set to 0. It means the corresponding R/G/B output will go high impedance instead of driving-high while displaying the low intensity characters or windows. After power on, this bit is reset and the R/G/B are push-pull outputs initially.

Bit 1 FAN - It enables the fan-in/fan-out functions when OSD is turned on from off state or vice versa. If this bit is set, it roughly takes about one second to fully display the whole menu. It also takes 1 second to disappear completely.

Bit 0 FBKGC - It determines the configuration of FBKG output pin. When it is clear, FBKG pin outputs high during displaying characters or windows. Otherwise, FBKG pin outputs high only during displaying characters.

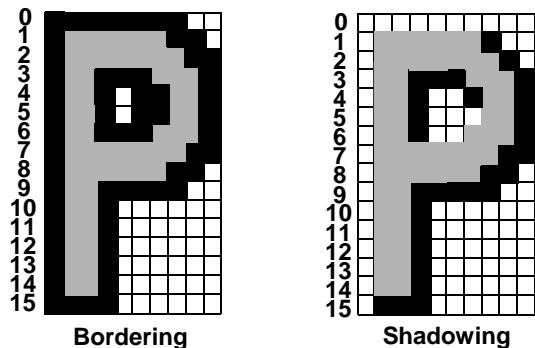
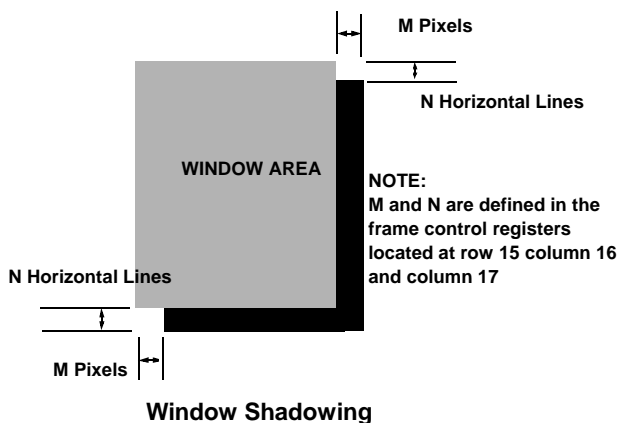

Figure 11. Character Bordering and Shadowing



Frame Control Register Row 15 Coln 16

	7	6	5	4	3	2	1	0
ROW 15 COLN 16	WW41	WW40	WW31	WW30	WW21	WW20	WW11	WW10

Bit 7-6 WW41, WW40 - It determines the shadow width of the window 4 when the window shadowing function is activated. Please refer to the following table for more details where M is the actual pixel number of the shadowing.

Table 3. Shadow Width Setting

(WW41, WW40)	(0, 0)	(0, 1)	(1, 0)	(1, 1)
Shadow Width M (unit in Pixel)	2	4	6	8

Bit 5-4 WW31, WW30 - Similarly as WW41, WW40, these two bits determine the shadow width of the window 3 when the window shadowing function is activated.

Bit 3-2 WW21, WW20 - Similarly as WW41, WW40, these two bits determine the shadow width of the window 2 when the window shadowing function is activated.

Bit 1-0 WW11, WW10 - Similarly as WW41, WW40, these two bits determine the shadow width of the window 1 when the window shadowing function is activated

Frame Control Register Row 15 Coln 17

	7	6	5	4	3	2	1	0
ROW 15 COLN 17	WH41	WH40	WH31	WH30	WH21	WH20	WH11	WH10

Bit 7-6 WH41, WH40 - It determines the shadow height of the window 4 when the window shadowing function is activated. Please refer to the following table for more details where N is the actual line number of the shadowing.

Table 4. Shadow Width Setting

(WH41, WH40)	(0, 0)	(0, 1)	(1, 0)	(1, 1)
Shadow Height N (unit in Line)	2	4	6	8

Bit 5-4 WH31, WH30 - Similarly as WH41, WH40, these two bits determine the shadow height of the window 3 when the window shadowing function is activated.

Bit 3-2 WH21, WH20 - Similarly as WH41, WH40, these two bits determine the shadow height of the window 2 when the window shadowing function is activated.

Bit 1-0 WH11, WH10 - Similarly as WH41, WH40, these two bits determine the shadow height of the window 1 when the window shadowing function is activated.

Frame Control Register Row 15 Coln 18

	7	6	5	4	3	2	1	0
ROW 15 COLN 18	RSPACE					TRIC	HPOL	VPOL
	MSB					LSB		

Bit 7-3 RSPACE - These 5 bits define the row to row spacing in unit of horizontal scan line. It means extra N lines, defined by this 5-bit value, will be appended for each display row. Because of the nonuniform expansion of BRM used by character height control, this register is usually used to maintain the constant OSD menu height for different display modes instead of adjusting the character height. The default value of it is 0. It means there is no any extra line inserted between row and row after power on. It can be used for Portrait monitor too when icon design is rotated 90 degree.

Bit 2 TRIC - Tri-state Control. This bit is used to control the driving state of output pins, R, G, B and FBKG when the OSD is disabled. After power on, this bit is reset and R, G, B and FBKG are in high impedance state while OSD being disabled. If it is set by MCU, these four output pins will drive low while OSD being in disabled state. Basically, the setting is dependent on the requirement of the external application circuit.

Bit 1 HPOL - This bit selects the polarity of the incoming horizontal sync signal (HFLB). If it is negative polarity, clear this bit. Otherwise, set this bit to 1 to represent the positive H sync signal. After power on, this bit is cleared.

Bit 0 VPOL - This bit selects the polarity of the incoming vertical sync signal (VFLB). If it is negative polarity, clear this bit. Otherwise, set this bit to 1 to represent the positive V sync signal. After power on, this bit is cleared.

- **NOTE: The registers located at column 19 of row 15 are reserved for the chip testing. In normal operation, they should not be programmed anytime.**

**PWM Control Registers Row 15 Col 20 to Col 31**

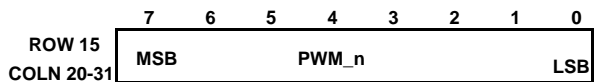

Bit 7-0 PWM\_n - This eight-bit value decides the output duty cycle and waveforms of PWM. There are maximum 12 channels of PWM. And the corresponding registers are located from column 20 to column 31 respectively on row 15.

The higher five bits (MSB) are used for the conventional PWM and the lower 3 bits (LSB) for the BRM. Please refer to the following figures for more information about BRM algorithm and PWM output waveform.

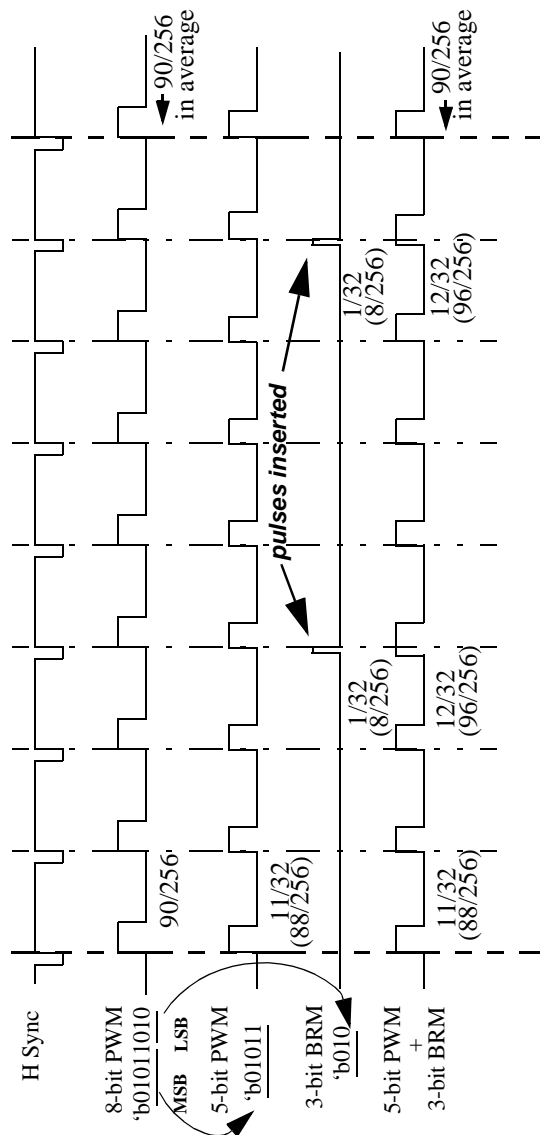

**Figure 12. Pure 8-bit PWM v.s. 5-bit PWM + 3-bit BRM**

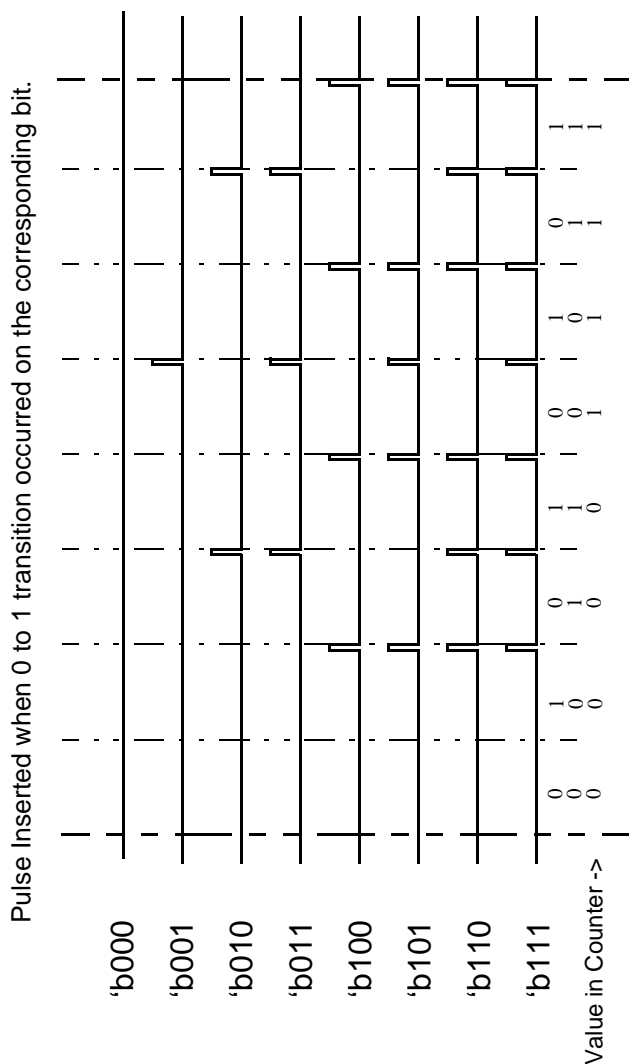

**Figure 13. BRM Pulse Insertion Algorithm**

A software called GMOSD-24 FONT EDITOR in IBM PC environment was written for MC141542P2 editing purposes. It generates a set of S-Record or Binary record for the desired display patterns to be masked onto the character ROM of the MC141542P2.

In order to have better character display within windows, we suggest you to place your designed character font in the centre of the 12x18 matrix, and let its spaces be equally located in the four sides of the matrix. The character \$00 is pre-defined for blank character, the character \$FF is pre-defined for full-filled character.

In order to avoid submersion of displayed symbols or characters into a background of comparable colors, a feature of bordering which encircles all four sides, or shadowing which encircles only the right and bottom sides of an individual display character is provided. Figure 11 shows how a character is being jacketed differently. To make sure that a character is bordered or shadowed correctly, at least one dot blank should be reserved on each side of the character font.

## Frame Format and Timing

Figure 14 illustrates the positions of all display characters on the screen relative to the leading edge of horizontal and vertical flyback signals. The shaded area indicates the area not interfered by the display characters. Notice that there are two components in the equations stated in Figure 14 for horizontal and vertical delays: fixed delays from the leading edge of HFLB and VFLB signals, regardless of the values of HORD and VERTD: (47 dots + phase detection pulse width) and one H scan line for horizontal and vertical delays, respectively; variable delays determined by the values of HORD and VERTD. Refer to Frame Control Registers COLN 9 and 10 for the definitions of VERTD and HORD. Phase detection pulse width is a function of the external charge-up resistor, which is the 1MΩ resistor in a series with 5.6 kΩ to VCO pin in the Application Diagram. Dot frequency is determined by the equation: H Freq. x 384 if the bit X32B is clear and H Freq. x 768 if bit X32B is set to 1. For example, dot frequency is 12.28 MHz if H freq is 32 KHz while bit X32B is 0. If X32B is 1, the dot frequency will be 24.57 MHz (double of the original one).

When double character width is selected for a row, only the even-numbered characters will be displayed, as shown in row 2. Notice that the total number of horizontal scan lines in the display frame is variable, depending on the chosen character height of each row. Care should be taken while configuring each row character height so that the last horizontal scan line in the display frame always comes out before the leading edge of VFLB of next frame to avoid wrapping display characters of the last few rows in the current frame into the next frame. The number of display dots in a horizontal scan line is always fixed at 360, regardless of row character width and the setting of bit X32B.

Although there are 30 character display registers that can be programmed for each row, not every programmed character can be shown on the screen in 384 dots resolution. Usually, only 24 characters can be shown in this resolution at most. This is induced by the retrace time that is required to retrace the H scan line. In other resolution, 768 dots, 30 characters can be displayed on the screen totally if the horizontal delay register is set properly.

Figure 15 illustrates the timing of all output signals as a function of window and fast blanking features. Line 3 of all three characters is used to illustrate the timing signals. The shaded area depicts the window area. Both the left hand side and right hand side characters are embodied in a window with only one difference: FBKGC bit. The middle character does not have a window as its background. Timing of signal FBKG depends on the configuration of FBKGC bit. The configuration of FBKGC bits affects only FBKG signal timing. Waveform 'R, G or B', which is the actual waveform at R, G, or B pin, is the logical OR of waveform 'character R, G or B' and waveform 'window R, G or B'. 'Character R, G, or B' and 'window R, G, or B' are internal signals for illustration purpose only.

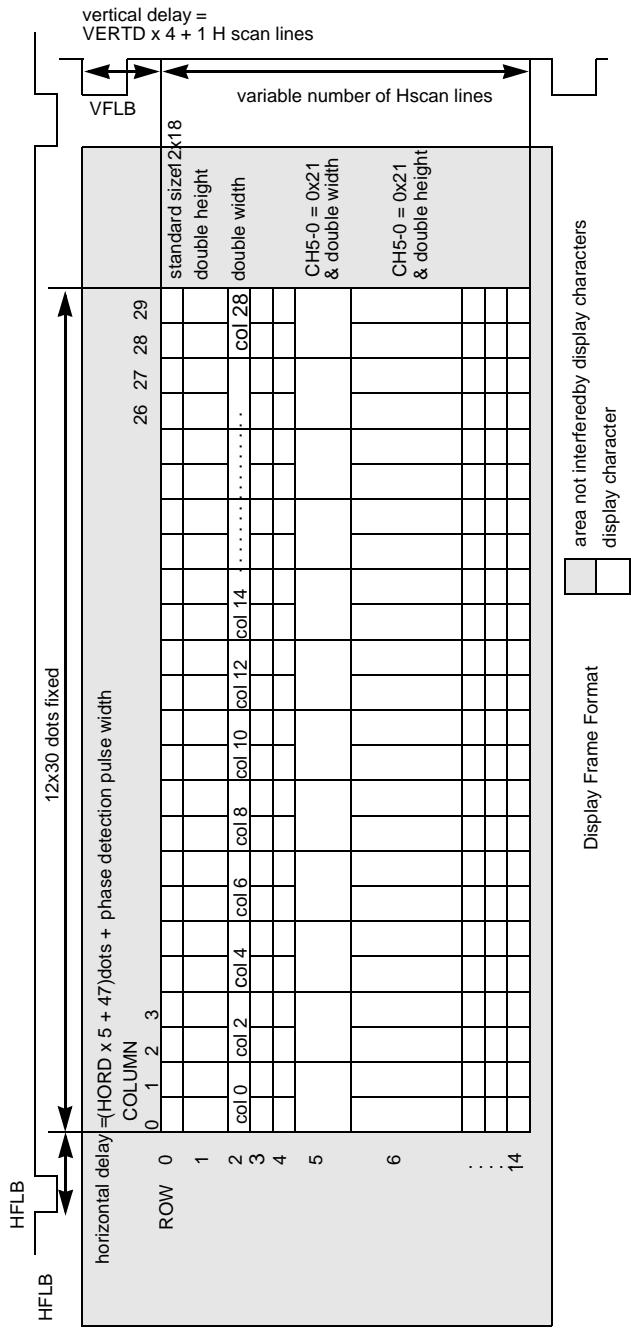

Figure 14. Display Frame Format

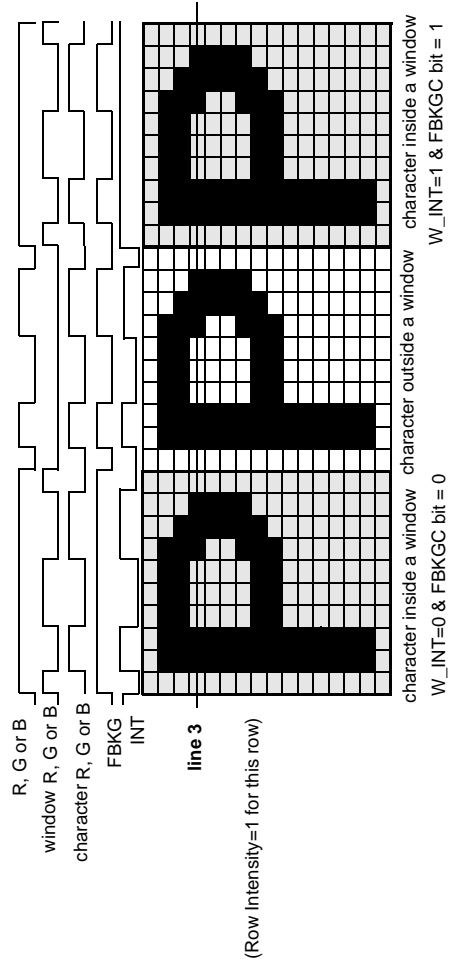

Figure 15. Timing of Output Signals

Timing of Output Signals as a Function of Window, FBKGC bit and Row Intensity Features

## FONT

MC141542P2 contains 256 character/symbol fonts including 240 normal fonts and 16 multi-color fonts. The normal fonts are located from number \$00 to \$EF. The 16 multi-color fonts occupy number \$F0 to \$FF and their patterns can be designed using Font Editor. See the figures on the next page for the details fonts mapping.

### Multi-Color Font

The color fonts comprises three different R, G, and B fonts. When the code of color font is accessed, the separate R/G/B dot pattern is output to the correspondig R/G/B output. See Figure. 16 for the sample displayed color font. No black color can be defined in color font: Black window underline the color font can make the dots(RGB=000) become black in color. It has to be consider during font design stage.

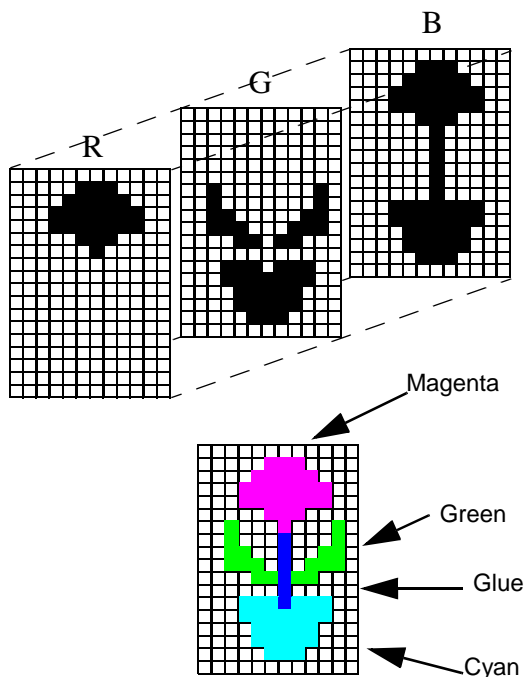

Figure 16. Example of Multi-Color Font

Table 5. The Multi-Color Font Color Selection

	R	G	B
Background Color	0	0	0
Blue	0	0	1
Green	0	1	0
Cyan	0	1	1
Red	1	0	0
Magenta	1	0	1
Yellow	1	1	0
White	1	1	1

### Icon Combination

User can create On-Screen menu based on those characters and icons. Please refer to Table 6 for Icon combination. Address \$00 & \$EF are pre-defined characters for testing.

## ROM CONTENT

Figures 17 – 20 show the ROM content of MC141542P2. Mask ROM is optional for custom parts.

Table 6. Combination Map

ICON	ROM ADDRESS(HEX)
ARABIC NUMERALS	08-11
ALPHABET	12-2D
EUROPEAN	2E-48
JAPANESE	49-81
SYMOBOLS	01-07, 82-C4
GEOMETRY	C5-EE
COLOR	F0-FF



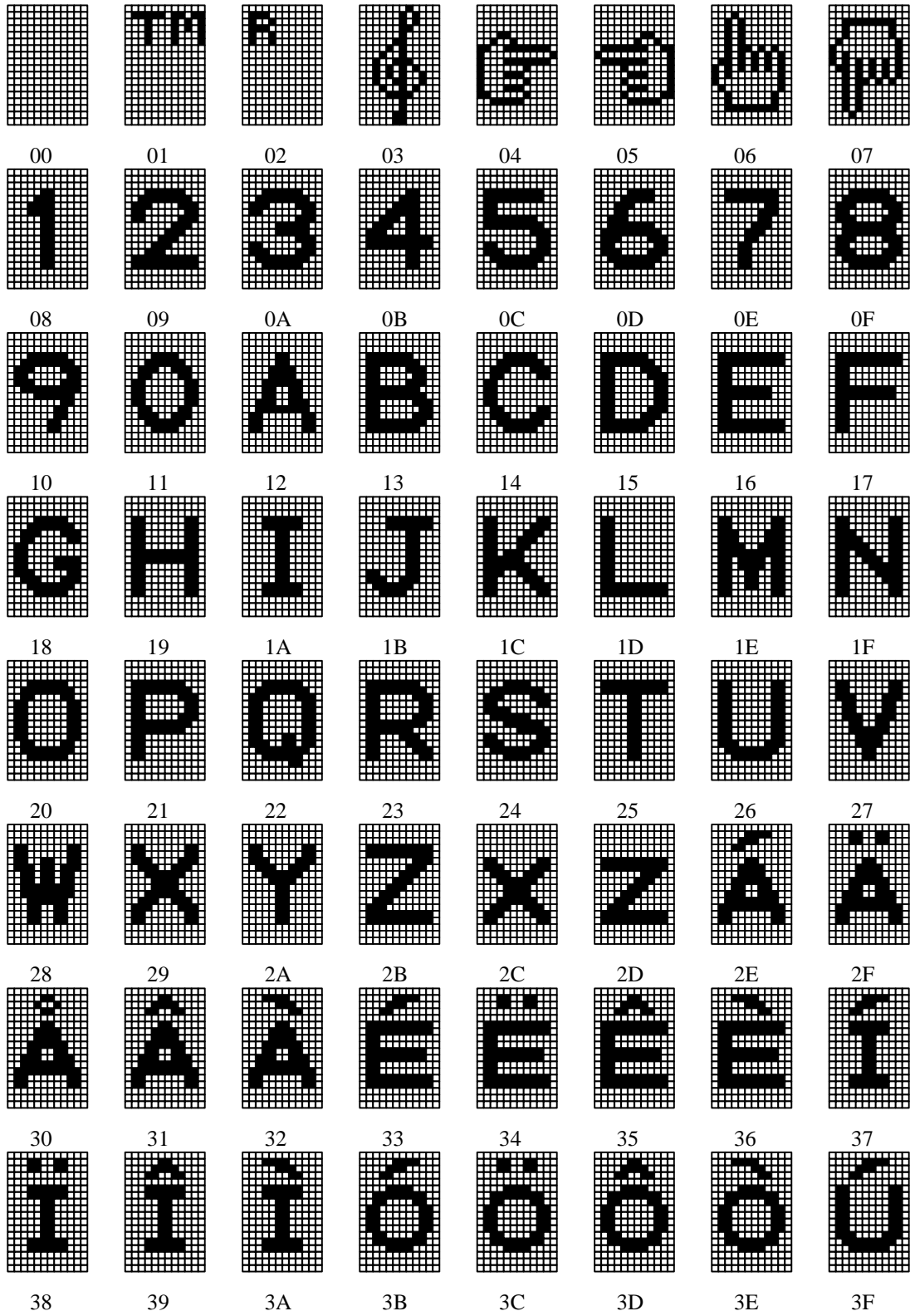

Figure 17. ROM 00 - 3F

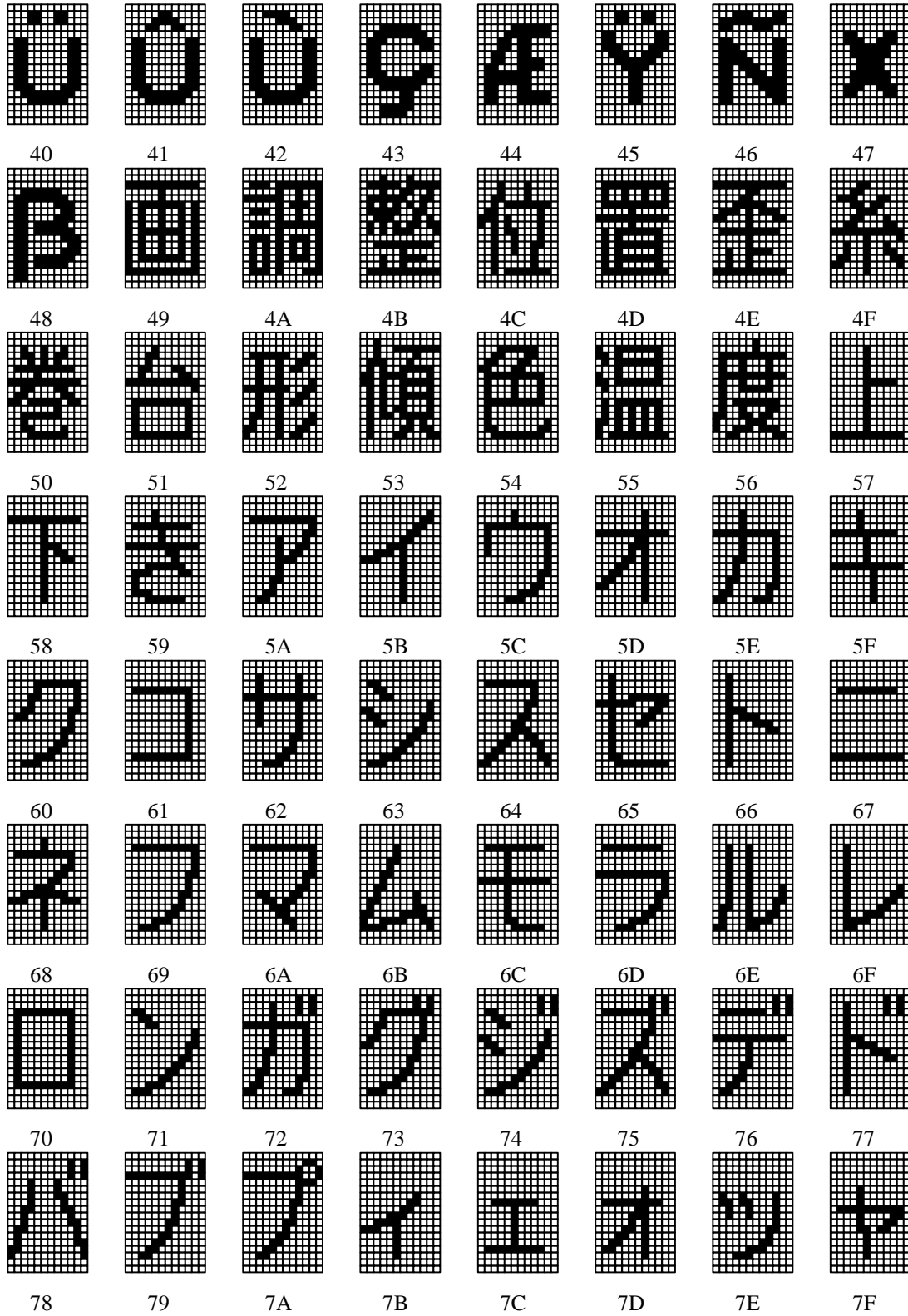

Figure 18. ROM 40 - 7F

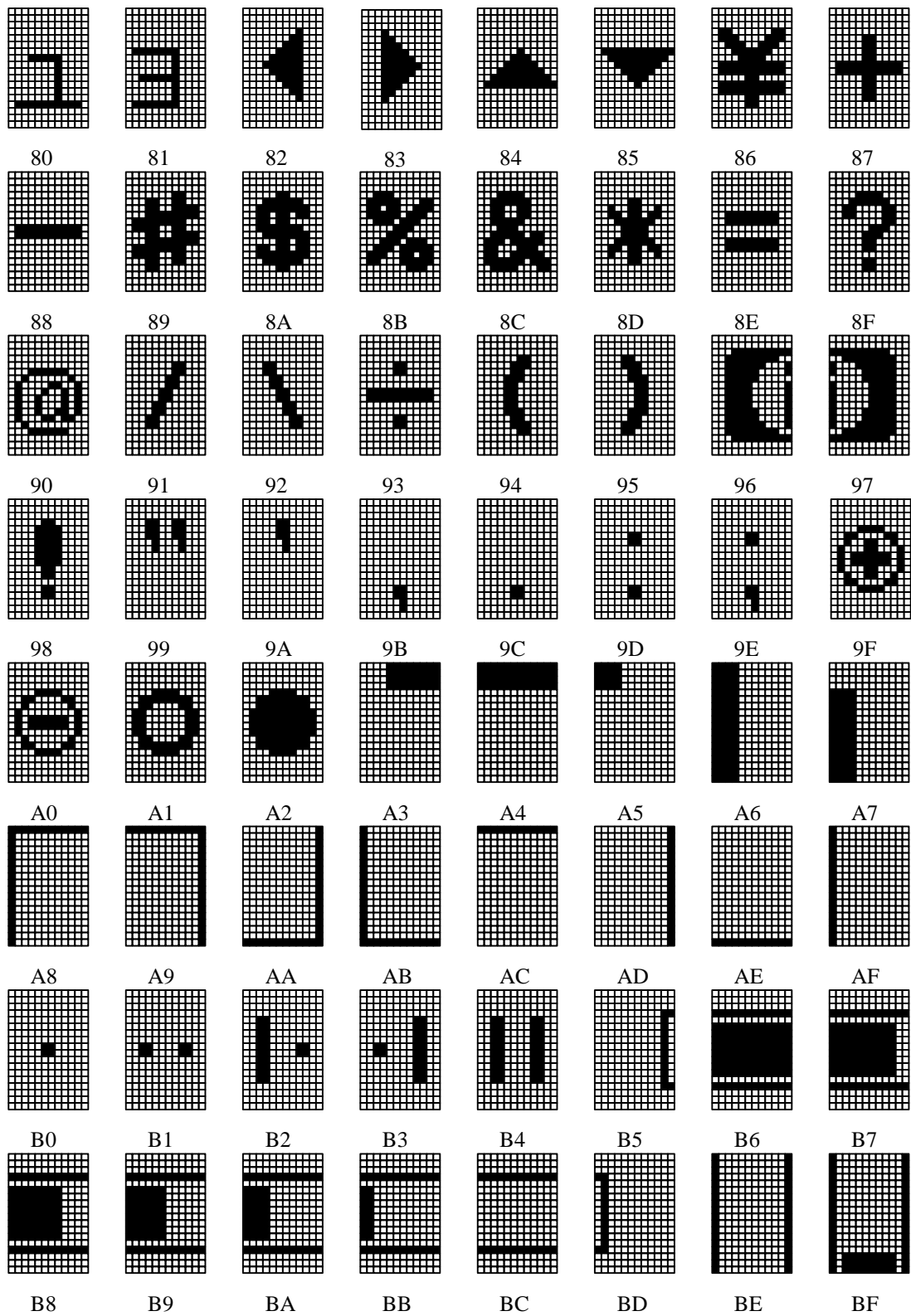

Figure 19. ROM 80 - BF

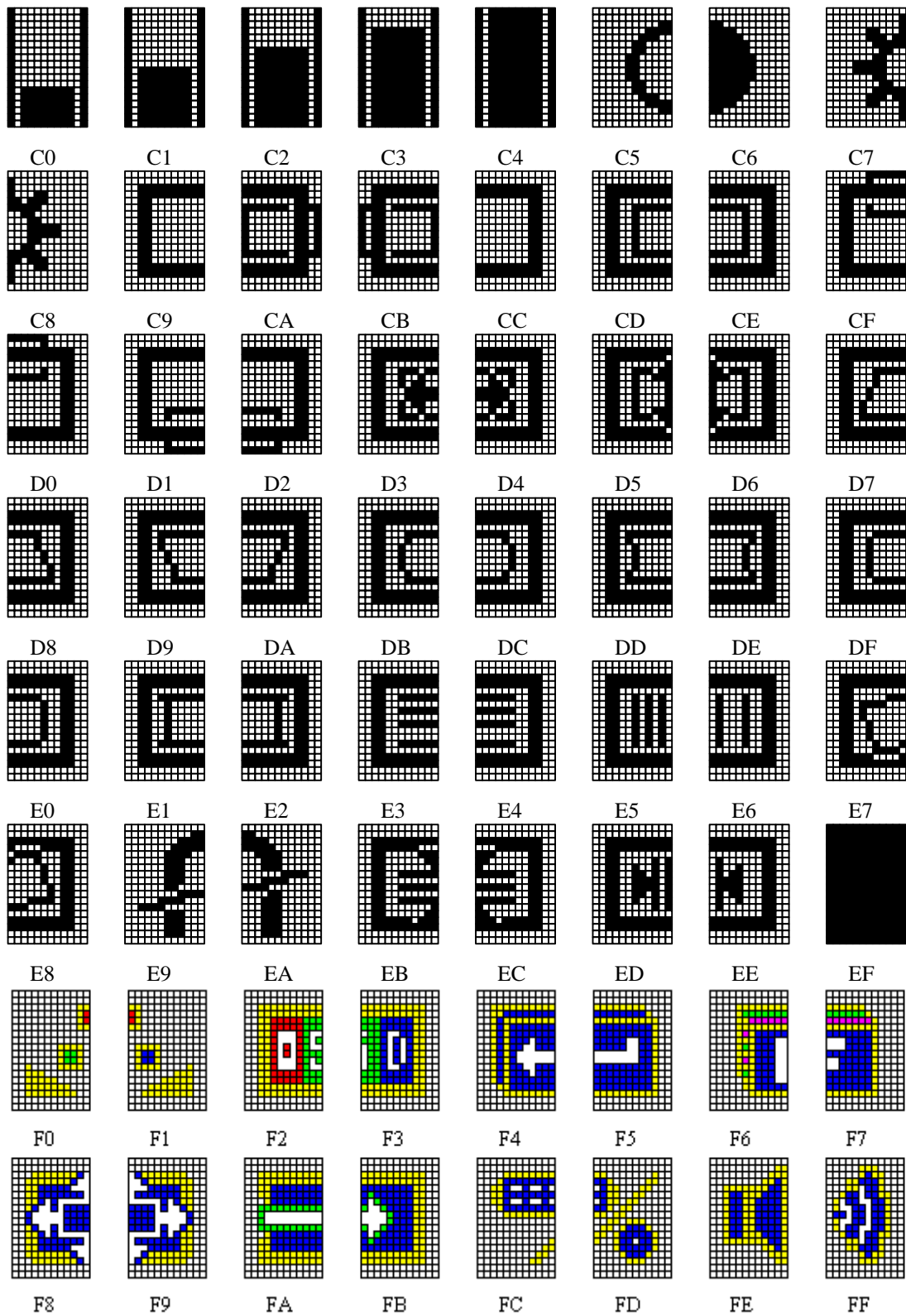

Figure 20. ROM C0 - FF











## DESIGN CONSIDERATIONS

### Distortion

Motorola's MC141542P2 has a built-in PLL for multisystems application. Pin 2 voltage is a dc biasing for the internal VCO in the PLL. When the input frequency (HFLB) in Pin 5 becomes higher, the VCO voltage will increase accordingly. The built-in PLL then has a higher locked frequency output. The frequency should be equal to  $384/768 \times \text{HFLB}$  (depends on resolution). It is the dot-clock in each horizontal line.

Display distortion is caused by noise in Pin 2. Positive noise makes VCO run faster than normal. The corresponding scan line will be shorter accordingly. In contrast, negative noise causes the scan line to be longer. The net result will be distortion on the display, especially on the right hand side with window turn on.

In order to have distortion-free display, the following recommendations should be considered.

- Only analog part grounds (Pin 2 to Pin 4) can be connected to Pin 1 ( $V_{SS(A)}$ ).  $V_{SS}$  and other grounds should connect to PCB common ground. Then the  $V_{SS(A)}$  and  $V_{SS}$  grounds can be connected by a bead core. Please refer to the application diagram (NOTE:  $V_{SS(A)}$  and  $V_{SS}$  are connected internally.)

- DC supply path for Pin 4 ( $V_{DD(A)}$ ) should be separated from other switching devices.
- LC filter should be connected between Pin 17 and Pin 4. Refer to the values used in the Application Diagram.
- Biasing and filter networks should be connected to Pin 2 and Pin 3. Refer to the recommended networks in the Application Diagram.
- Two small capacitors can be added between Pin1-Pin2 and Pin3-Pin4 to filter VCO noise if necessary. Values should be small enough to avoid picture unlocking caused by temperature variation.

### Jittering and Unlocking

Most display jittering and unlocking is caused by HFLB in Pin 5. Care must be taken if the HFLB signal comes from the flyback transformer. A short path and shielded cable are recommended for a clean signal. Buffer is needed for both HFLB and VFLB inputs. Refer to the value used in the Application Diagram.

Note: The bead core added between  $V_{SS(A)}$  and  $V_{SS}$  can also enhance the OSD stability in high frequency HFLB operation.

### Display Dancing

Most display dancing is caused by interference of the serial bus. It can be avoided by adding resistors in the bus in series.

## APPLICATION DIAGRAM

