

Document	853-1451
ECN No.	00210
Date of Issue	August 17, 1990
Status	Product Specification
RF Communications	

NE/SA5750

Audio processor – companding and amplifier section

special components for cellular radio

DESCRIPTION

The NE/SA5750 is a high performance low power audio signal processing system. The NE/SA5750 subsystems include a low noise microphone preamplifier with adjustable gain, a noise cancellation switching amplifier with adjustable threshold, a voice operated transmitter (VOX) switch, VOX control, an audio compressor with buffered input, audio expander, a unity gain power amplifier to drive a speaker, a summing power amplifier for sidetone attenuation and headphone (earpiece) drive, and an internal bandgap voltage regulator with power down capability. When used with Signetics' NE/SA5751, the complete audio processing function of an AMPS or TACS cellular telephone is easily implemented. The NE/SA5750 can also be used without the NE/SA5751 in a wide variety of radio communications applications.

FEATURES

- High performance
- 5V supply
- Adjustable VOX and noise cancellation threshold
- Adjustable gain preamplifier
- Audio companding
- ESD protected
- Open collector VOX output
- Logic inputs CMOS compatible
- Power down mode
- Built-in drivers for speaker and earpiece
- Few external components
- SOL and DIP packages

BENEFITS

- Very compact applications
- Long battery life in portable equipment
- Complete cellular audio function with the SA5751

APPLICATIONS

- Cellular radio
- Mobile communications
- High performance cordless telephones
- 2-way radio

ORDERING INFORMATION

DESCRIPTION	TEMPERATURE RANGE	ORDER CODE
24-Pin Plastic DIP	0 to +70°C	NE5750N
24-Pin Plastic SOL	0 to +70°C	NE5750D
24-Pin Plastic DIP	-40 to +85°C	SA5750N
24-Pin Plastic SOL	-40 to +85°C	SA5750D

PIN CONFIGURATION

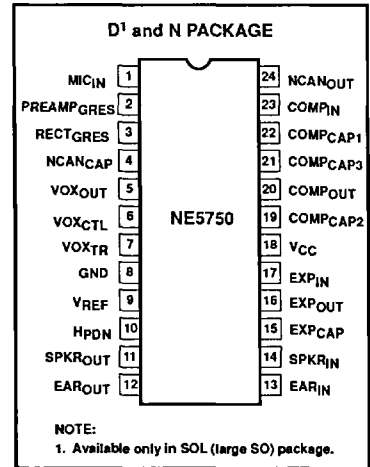

Audio processor – companding and amplifier section

NE/SA5750

PIN DESCRIPTIONS

PIN NO.	SYMBOL	DESCRIPTION
1	MIC _{IN}	Microphone input
2	PREAMP _{GRES}	Preamplifier gain resistor
3	RECT _{GRES}	Rectifier gain resistor
4	NCAN _{CAP}	Noise cancellation timing capacitor
5	VOX _{OUT}	Voice operated transmission output
6	VOX _{CTL}	Voice operated transmission control
7	VOX _{TR}	Voice operated transmission threshold resistor
8	GND	Ground
9	V _{REF}	Reference voltage
10	H _{PDN}	Hardware power down
11	SPKR _{OUT}	Speaker output
12	EAR _{OUT}	Earpiece output
13	EAR _{IN}	Earpiece input, side tone input
14	SPKR _{IN}	Speaker input
15	EXP _{CAP}	Expander timing capacitor
16	EXP _{OUT}	Expander output
17	EXP _{IN}	Expander input
18	V _{CC}	Positive supply
19	COMP _{CAP2}	Compressor timing capacitor 2
20	COMP _{OUT}	Compressor output
21	COMP _{CAP3}	Compressor timing capacitor 3
22	COMP _{CAP1}	Compressor timing capacitor 1
23	COMP _{IN}	Compressor input
24	NCAN _{OUT}	Noise cancellation output

BLOCK DIAGRAM

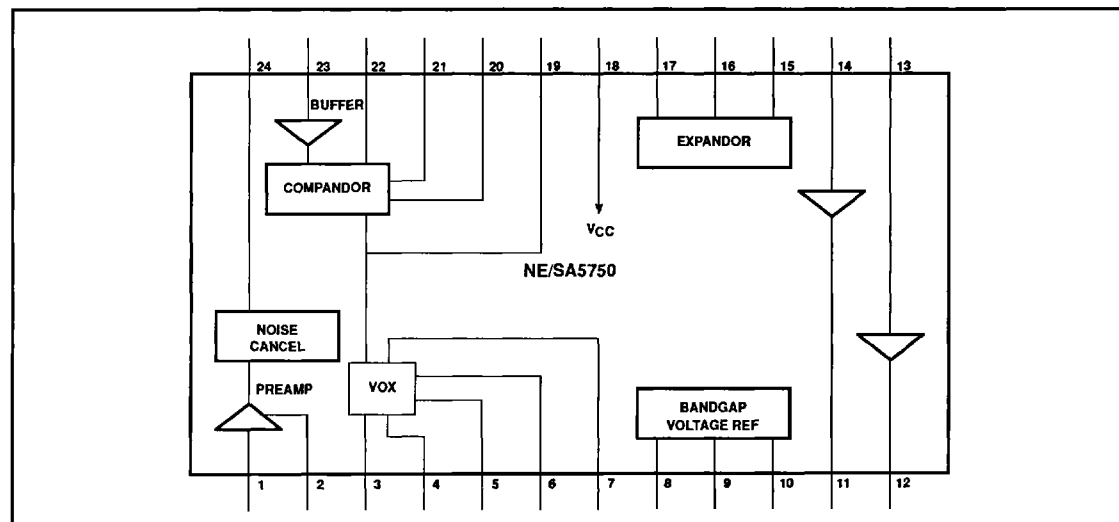

Audio processor – companding and amplifier section

NE/SA5750

ABSOLUTE MAXIMUM RATINGS

SYMBOL	PARAMETER	RATING	UNIT
V_{CC}	Power supply voltage Voltage applied to any pin	6 -0.3 to ($V_{CC} + 0.3$)	V V
T_{STG}	Storage temperature	-65 to +150	°C
T_A	Ambient operating temperature NE5750 SA5750	0 to 70 -40 to +85	°C

DC ELECTRICAL CHARACTERISTICS $T_A = 25^\circ\text{C}$, $V_{CC} = +5.0\text{V}$, $0\text{dB} = 77.5\text{mV}_{\text{RMS}}$. See test circuit, Figure 4.

SYMBOL	PARAMETER	TEST CONDITIONS	LIMITS			UNIT
			MIN	TYP	MAX	
V_{CC}	Supply voltage		4.75	5.0	5.25	V
I_{CC}	Supply current	No signal Power down mode		8.4 1.8	12.0 3.0	mA mA
Z_L	Load impedance pins NCAN _{OUT} , EXP _{OUT}		50			k Ω
	COMP _{OUT} ¹		10			k Ω
Z_{IN}	Input impedance COMP _{IN} , MIC _{IN} , SPKR _{IN}		40	50	60	k Ω
	EXP _{IN} ²		2.0	2.5		k Ω
	Noise cancellation current	Pin 7, grounded	40	50	60	μA
V_{OS}	DC offset NCAN _{OUT} ³		-50		50	mV

NOTES:

- Compressor is tested in production with 50k Ω load.
- Not tested in production.
- Offset values are identical for both gain states of noise reduction circuit.

AC ELECTRICAL CHARACTERISTICS $T_A = 25^\circ\text{C}$, $V_{CC} = +5.0\text{V}$, $0\text{dB level} = 77.5\text{mV}_{\text{RMS}}$. See test circuit, Figure 4.

SYMBOL	PARAMETER	TEST CONDITIONS	LIMITS			UNIT
			MIN	TYP	MAX	
	Preamplifier gain range Preamplifier voltage gain 0dB Preamplifier voltage gain 40dB	Pin 2 open Pin 2 AC ground	0 -1.0 39.0	0 40	40 1.0 41.0	dB dB dB
	Preamplifier noise density	Pin 2 AC grounded RS = 0 – 50k Ω unweighted 20Hz–20kHz		7		nV/ $\sqrt{\text{Hz}}$
		weighted CCIR DIN45405 20–20kHz		8		nV/ $\sqrt{\text{Hz}}$
	Switch amplifier gain		9	10	11	dB
	Sidetone attenuation range				30	dB
Compressor 1kHz, all tests¹						
COMP _{OUT}	Compressor error at -21dB output level	Input level = -42dB		0.38		dB
COMP _{OUT}	Compressor error at -10dB output level	Input level = -20dB	-1.0		1.0	dB
COMP _{OUT}	Compressor error at 0dB output level	Input level = 0dB	-1.5	0.12	1.5	dB
COMP _{OUT}	Compressor error at +5dB output level	Input level = +10dB	-1.0		1.0	dB
COMP _{OUT}	Compressor error at +12.3dB output level	Input level = +24.6dB	-1.0		1.0	dB
EXP _{OUT}	Expander error at -42dB output level	Input level = -21dB		-0.41		dB
EXP _{OUT}	Expander error at -21dB output level	Input level = -10.5dB	-1.0		1.0	dB

Audio processor – companding and amplifier section

NE/SA5750

AC ELECTRICAL CHARACTERISTICS $T_A = 25^\circ\text{C}$, $V_{CC} = +5.0\text{V}$, 0dB level = 77.5mV_{RMS}. See test circuit, Figure 4.

SYMBOL	PARAMETER	TEST CONDITIONS	LIMITS			UNIT
			MIN	TYP	MAX	
EXP _{OUT}	Expander error at -10dB output level	Input level = -5dB	-1.0		1.0	dB
EXP _{OUT}	Expander error at 0dB output level	Input level = 0dB	-1.5	-0.18	1.5	dB
EXP _{OUT}	Expander error at +10dB output level	Input level = +5dB	-1.0		1.0	dB
EXP _{OUT}	Expander error at +24.6dB output level ²	Input level = +12.3dB	-1.5		1.5	dB
EXP _{OUT}	Expander V _{OS}	No signal	-50.0		50.0	mV
EXP _{OUT}	Expander output DC shift	No signal to 0dB	-100		100	mV
	Timing capacitors compandor			2.2		μF
THD	Total harmonic distortion					
	Compressor	1kHz, 0dB		0.09	1	%
	Expander	1kHz, 0dB		0.09	1	%
	NCAN _{OUT}		1kHz, Pin 2 open output level = 0dB		0.18	1
1kHz, Pin 2 open output level = +25dB				0.13	1	%
	Speaker amplifier Drive capability				40	mA _{P-P}
	Output swing (<1% THD)	50Ω load	2	3.2		V _{P-P}
		100Ω load	3	4.1		V _{P-P}
		No load	4	4.9		V _{P-P}
	Ear amplifier Drive capability				10	mA _{P-P}
	Output swing (<1% THD)	300Ω load	3	4.3		V _{P-P}
		2000Ω load	4	4.9		V _{P-P}
		No load	4	4.9		V _{P-P}
VOX _{OUT}	Sink current				0.5	mA
	Low level High level	Open collector I _L = 0.5mA	4	0.07 5	0.4	V V
VOX _{CTL}	Input current	Low	-50	-21	0	μA
		High	-10		+10	μA
	Input level	Low	0		1.5	V
		High	3.5		5	V
HP _{DN}	Input current	Low	-10		+10	μA
		High	-10		+10	μA
	Input level	Low	0		1.5	V
		High	3.5		5	V
	Reference filter capacitor			10		μF

NOTE:

1. Measurements are relative to 0dB output.
2. Measurement is absolute and indicative of the output dynamic range capability.

Audio processor – companding and amplifier section

NE/SA5750

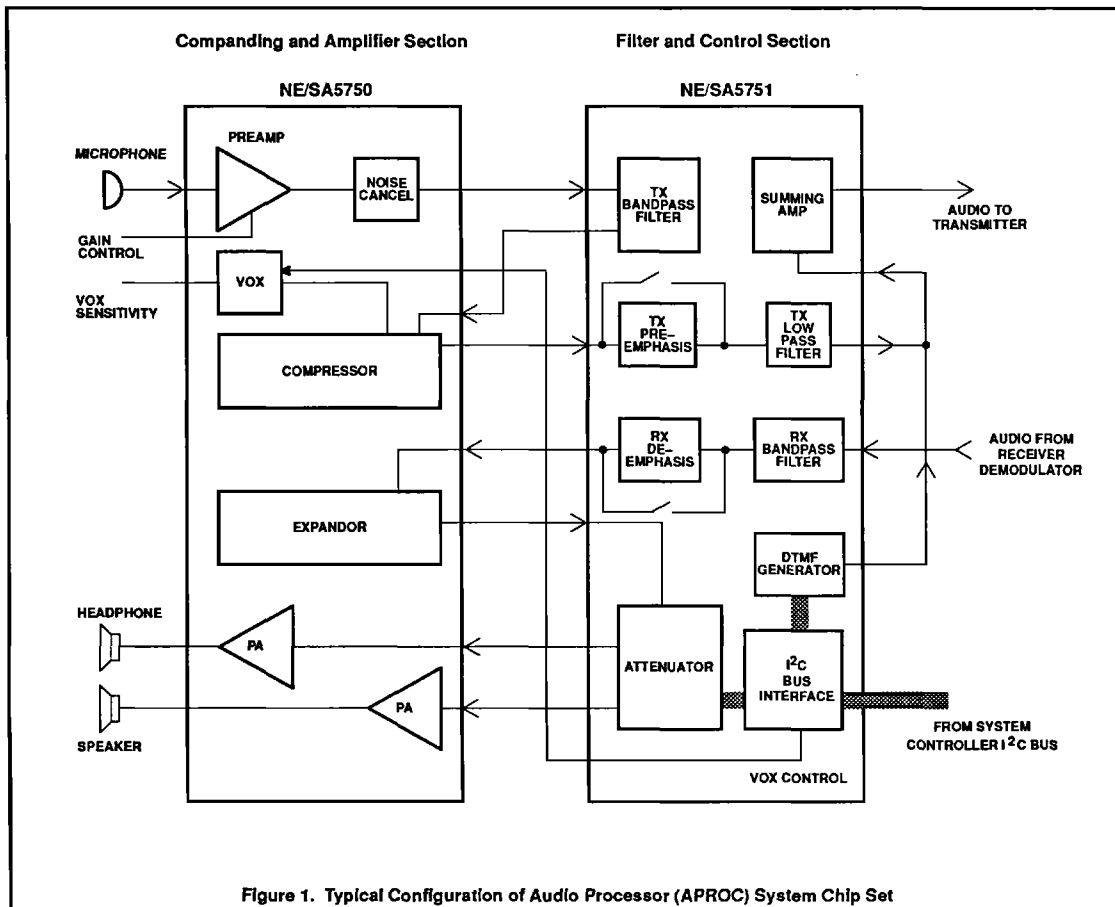

Audio processor – companding and amplifier section

NE/SA5750

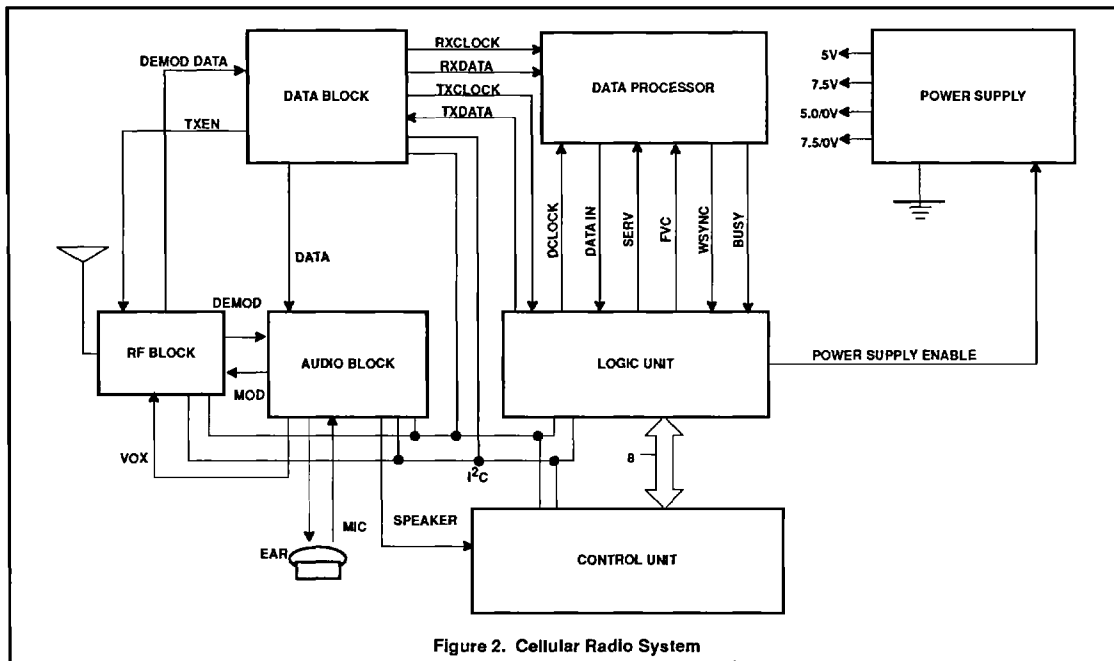

Figure 2. Cellular Radio System

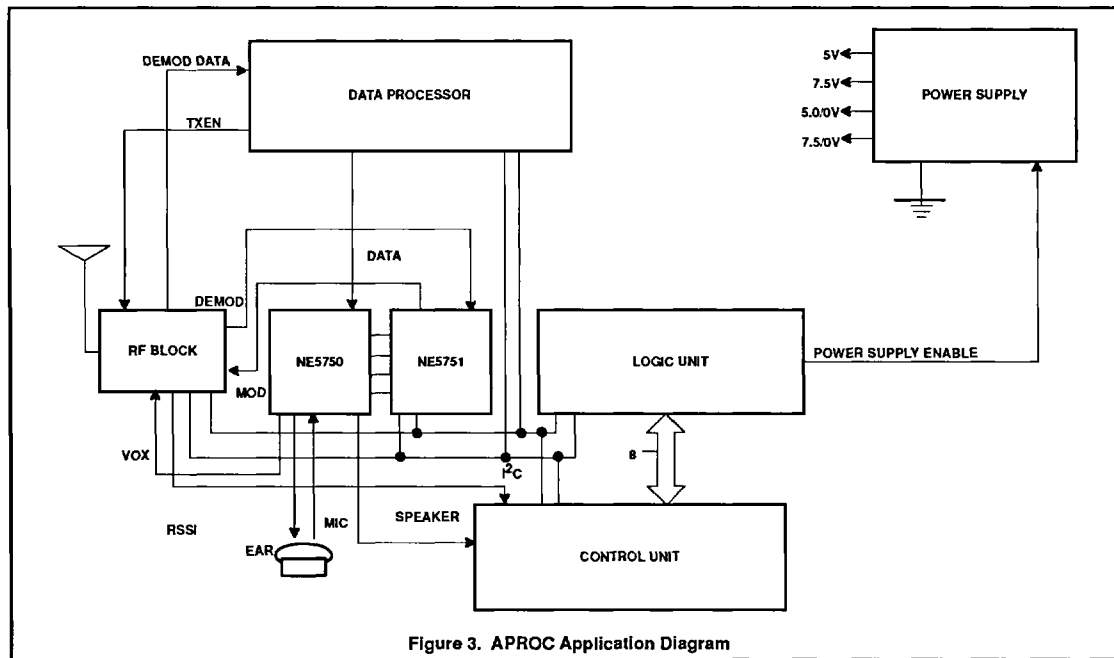

Figure 3. APROC Application Diagram

Audio processor – companding and amplifier section

NE/SA5750

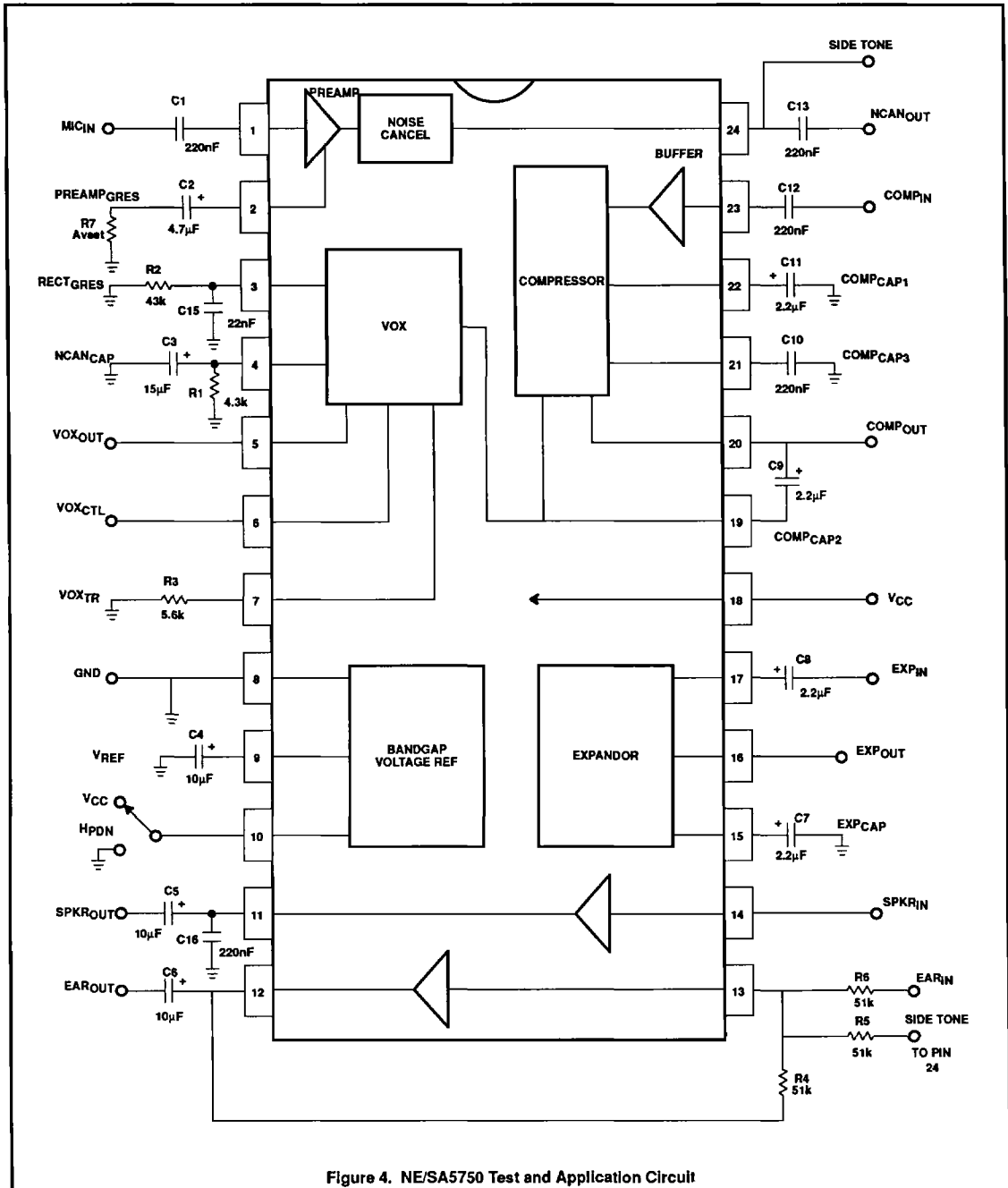

Figure 4. NE/SA5750 Test and Application Circuit