



SGF35 — For C to Ku-Band Local Oscillator and Amplifier

N-Channel GaAs MESFET

Features

- Lower Phase Noise.
- Highly reliable protection film.
- Automatic surface mounting supported.
- MCPH4 package.

Specifications

Absolute Maximum Ratings at Ta=25°C

Parameter	Symbol	Conditions	Ratings	Unit
Drain-to-Source Voltage	V _{DS}		6	V
Gate-to-Source Voltage	V _{GS}		-5	V
Drain Current	I _D		100	mA
Allowable Power Dissipation	P _D	Mounted on copper foil (area : 0.96mm ²) Glass epoxy board (145X80X1.6mm)	400	mW
Junction Temperature	T _J		150	°C
Storage Temperature	T _{stg}		-55 to +150	°C

Electrical Characteristics at Ta=25°C

Parameter	Symbol	Conditions	Ratings			Unit
			min	typ	max	
Gate-to-Source Leakage Current	I _{GSO}	V _{GS} =-5V			-10	μA
Saturated Drain Current	I _{DSS}	V _{DS} =3V, V _{GS} =0	30	50	70	mA
Cutoff Voltage	V _{GS(off)}	V _{DS} =3V, I _D =100μA	-0.5	-1.6	-2.7	V
Forward Transfer Admittance	y _{fs}	V _{DS} =3V, I _D =10mA		34		mS

■ Any and all SANYO products described or contained herein do not have specifications that can handle applications that require extremely high levels of reliability, such as life-support systems, aircraft's control systems, or other applications whose failure can be reasonably expected to result in serious physical and/or material damage. Consult with your SANYO representative nearest you before using any SANYO products described or contained herein in such applications.

■ SANYO assumes no responsibility for equipment failures that result from using products at values that exceed, even momentarily, rated values (such as maximum ratings, operating condition ranges, or other parameters) listed in products specifications of any and all SANYO products described or contained herein.

SGF35

Package Dimensions

unit : mm

1316

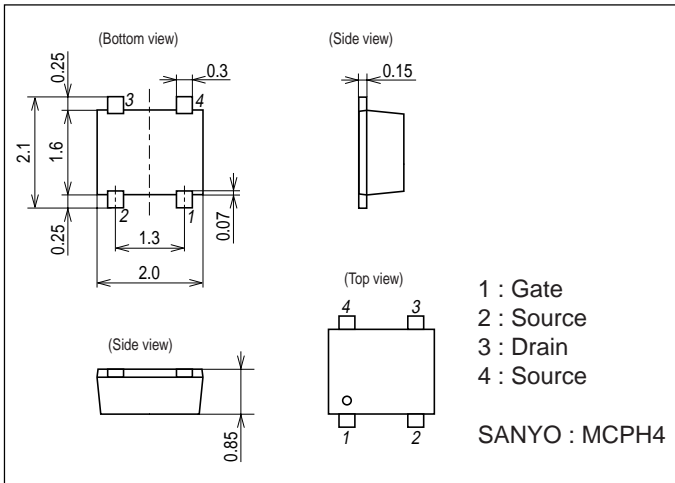

S-Parameter

SGF35

$V_{DS}=3V$ $I_{DS}=30mA$

FREQUENCY MHz	S11		S21		S12		S22	
	MAG	ANG	MAG	ANG	MAG	ANG	MAG	ANG
3000.0000	0.801	-74.0	2.944	111.4	0.048	56.0	0.675	-35.0
4000.0000	0.731	-94.3	2.622	93.6	0.052	53.0	0.659	-43.3
5000.0000	0.678	-110.8	2.363	78.4	0.056	54.3	0.646	-50.0
6000.0000	0.622	-122.9	2.230	65.2	0.063	58.6	0.636	-56.5
7000.0000	0.544	-137.6	2.181	50.8	0.077	60.6	0.630	-66.3
8000.0000	0.459	-162.4	2.120	34.6	0.094	58.2	0.627	-76.9
9000.0000	0.446	168.1	2.007	18.3	0.112	53.3	0.614	-87.1
10000.0000	0.475	147.3	1.904	4.1	0.133	48.1	0.587	-96.7
11000.0000	0.488	129.6	1.857	-11.1	0.156	40.4	0.543	-111.2
12000.0000	0.500	104.0	1.827	-29.0	0.187	27.9	0.550	-133.8
13000.0000	0.575	74.3	1.676	-49.1	0.200	13.0	0.573	-158.2
14000.0000	0.669	58.8	1.467	-65.7	0.206	-0.4	0.546	-178.2
15000.0000	0.716	52.3	1.345	-81.0	0.213	-11.5	0.507	159.5
16000.0000	0.752	40.7	1.257	-99.6	0.226	-27.8	0.516	126.4

SGF35

$V_{DS}=3V$ $I_{DS}=30mA$

FREQUENCY MHz	GUmax dB	GAmix dB	$ S21 ^2$ dB	$ S12 ^2$ dB	K	Delay ns	Mason's U dB	G1 dB	G2 dB
3000.0000	16.47		9.38	-26.35	0.700	0.054	23.536	4.45	2.64
4000.0000	14.17		8.37	-25.60	0.910	0.045	22.112	3.32	2.47
5000.0000	12.49	14.50	7.47	-25.04	1.080	0.040	20.756	2.67	2.34
6000.0000	11.33	13.07	6.96	-24.06	1.100	0.031	19.970	2.12	2.25
7000.0000	10.49	12.53	6.77	-22.29	1.110	0.041	20.335	1.52	2.19
8000.0000	9.72	12.15	6.52	-20.57	1.050	0.044	18.841	1.03	2.17
9000.0000	9.07		6.05	-19.00	0.950	0.047	17.935	0.96	2.06
10000.0000	8.54		5.59	-17.50	0.850	0.037	17.025	1.11	1.84
11000.0000	8.07		5.37	-16.13	0.810	0.044	14.524	1.18	1.52
12000.0000	8.05		5.23	-14.58	0.700	0.057	14.643	1.25	1.57
13000.0000	7.96		4.49	-13.97	0.620	0.057	14.090	1.75	1.73
14000.0000	7.45		3.33	-13.74	0.570	0.033	13.143	2.58	1.54
15000.0000	6.99		2.58	-13.42	0.570	0.046	11.181	3.12	1.29
16000.0000	6.95		1.99	-12.90	0.540	0.055	10.481	3.62	1.35

SGF35

S-Parameter $V_{DS}=3V$ $I_{DS}=30mA$, START 3GHz STOP 16GHz

S11

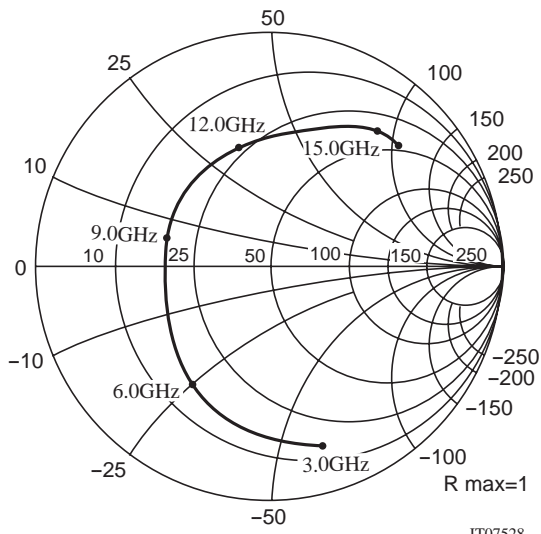

S21

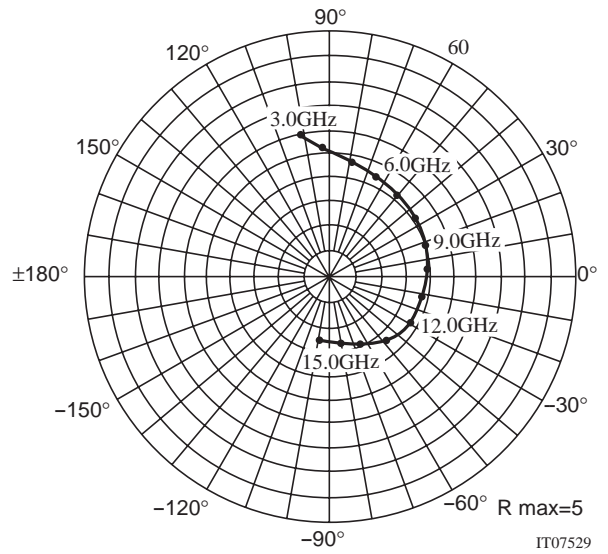

S12

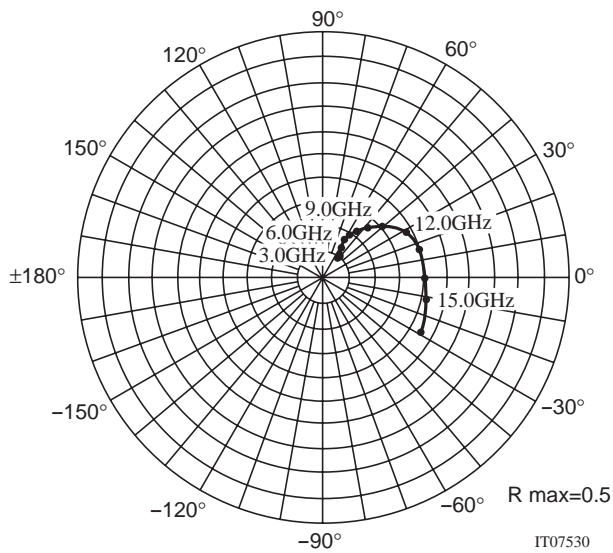

S22

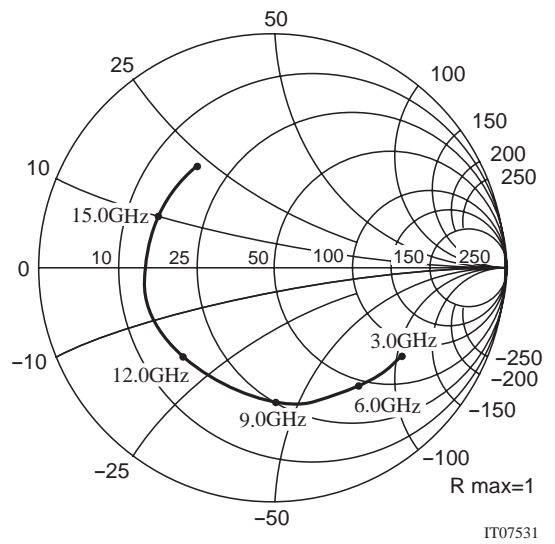

SGF35

Oscillation Characteristics Measured by the Application JIG for SGF35

Equivalent Circuit of the Application JIG

(Recommended bias condition is $V_D=5V$, $I_D=31mA$)

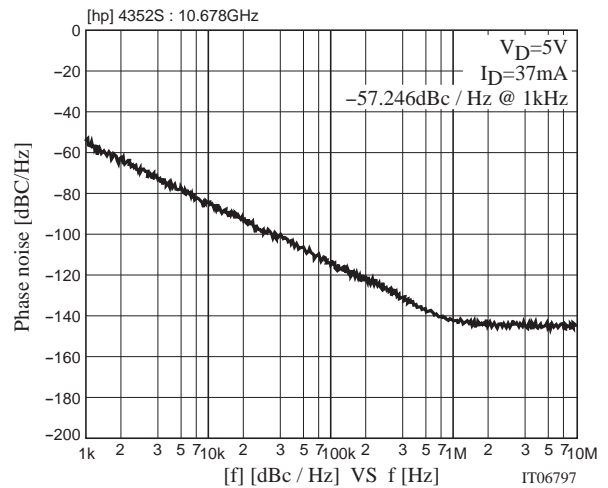
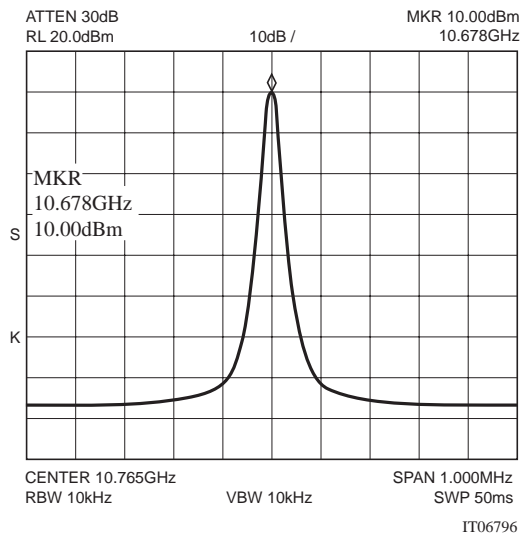
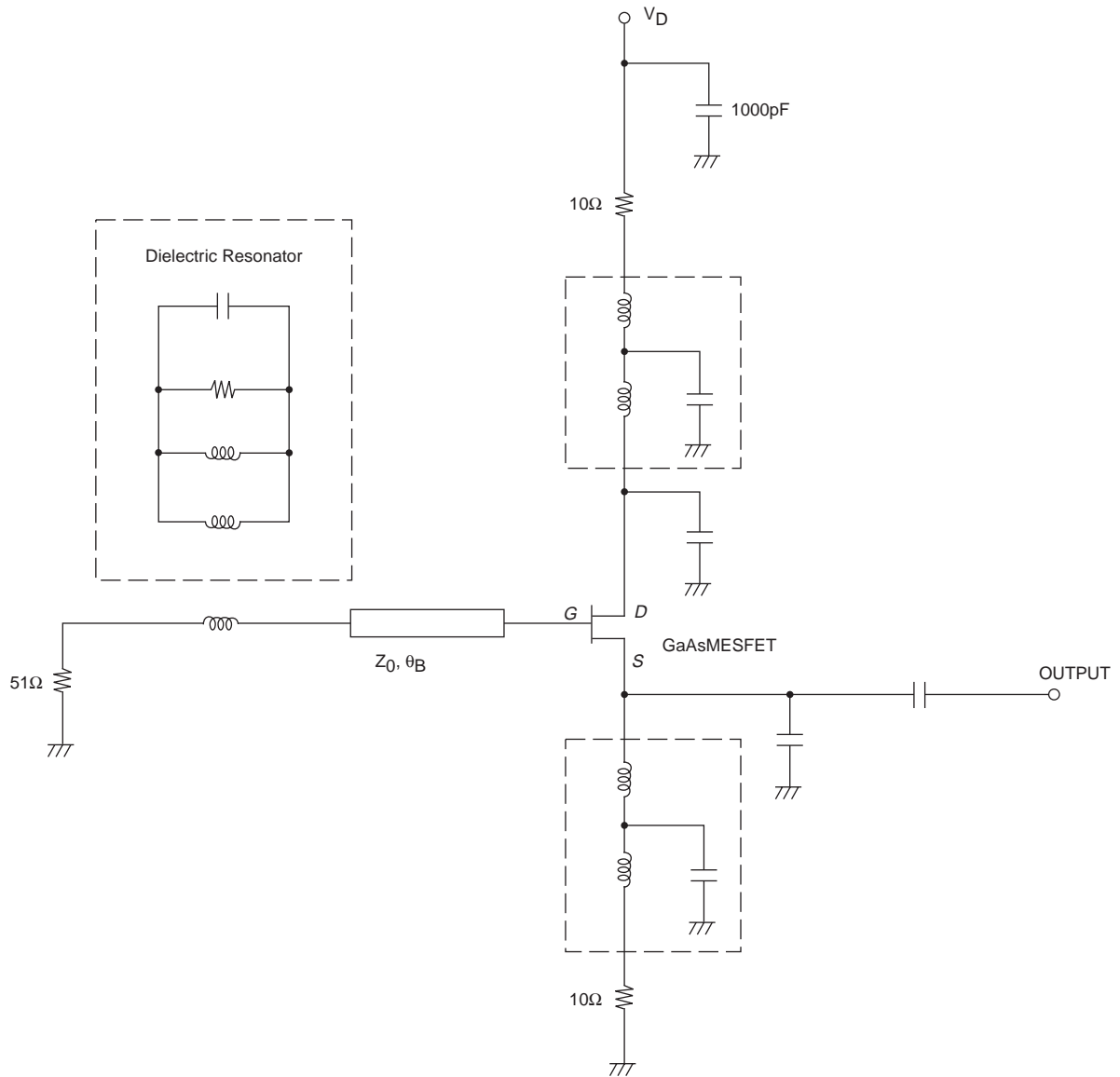

- Specifications of any and all SANYO products described or contained herein stipulate the performance, characteristics, and functions of the described products in the independent state, and are not guarantees of the performance, characteristics, and functions of the described products as mounted in the customer's products or equipment. To verify symptoms and states that cannot be evaluated in an independent device, the customer should always evaluate and test devices mounted in the customer's products or equipment.
- SANYO Electric Co., Ltd. strives to supply high-quality high-reliability products. However, any and all semiconductor products fail with some probability. It is possible that these probabilistic failures could give rise to accidents or events that could endanger human lives, that could give rise to smoke or fire, or that could cause damage to other property. When designing equipment, adopt safety measures so that these kinds of accidents or events cannot occur. Such measures include but are not limited to protective circuits and error prevention circuits for safe design, redundant design, and structural design.
- In the event that any or all SANYO products(including technical data, services) described or contained herein are controlled under any of applicable local export control laws and regulations, such products must not be exported without obtaining the export license from the authorities concerned in accordance with the above law.
- No part of this publication may be reproduced or transmitted in any form or by any means, electronic or mechanical, including photocopying and recording, or any information storage or retrieval system, or otherwise, without the prior written permission of SANYO Electric Co., Ltd.
- Any and all information described or contained herein are subject to change without notice due to product/technology improvement, etc. When designing equipment, refer to the "Delivery Specification" for the SANYO product that you intend to use.
- Information (including circuit diagrams and circuit parameters) herein is for example only ; it is not guaranteed for volume production. SANYO believes information herein is accurate and reliable, but no guarantees are made or implied regarding its use or any infringements of intellectual property rights or other rights of third parties.

This catalog provides information as of March, 2004. Specifications and information herein are subject to change without notice.