

SG400(R,U,W,EX)22

GATE TURN-OFF THYRISTOR

CHOPPER, INVERTER APPLICATION

- Repetitive Peak Off-State Voltage
: $V_{DRM}=1300, 1600, 1800, 2500V$
- R.M.S On-State Current : $I_T(RMS)=150A$
- Peak Turn-Off Current : $I_{TGQM}=400A$
- Critical Rate of Rise of On-State Current
: $di/dt=200A/\mu s$
- Critical Rate of Rise of Off-State Voltage
: $dv/dt=600V/\mu s$

MAXIMUM RATINGS

CHARACTERISTIC		SYMBOL	RATING	UNIT
Repetitive Peak Off-State Voltage	SG400R22	VDRM	1300	V
	SG400U22		1600	
	SG400W22		1800	
	SG400EX22		2500	
Repetitive Peak Reverse Voltage		VRRM	15	V
Peak Turn-off Current (Note 1)		I_{TGQM}	400	A
R.M.S On-State Current (Note 2)		$I_T(RMS)$	150	A
Peak One Cycle Surge On-State Current (Non-Repetitive)		I_{TSM}	2600(50Hz)	A
			2860(60Hz)	
Critical Rate of Rise of On-State Current (Note 3)		di/dt	200	A/ μs
Peak Forward Gate Current (Note 4)		I_{FGM}	20	A
Average Forward Gate Power Dissipation		$P_{G(AV)}$	4	W
R.M.S Reverse Gate Current		$I_{RG(RMS)}$	20	A
Peak Reverse Gate Power Dissipation (Note 5)		P_{RGM}	2	kW
Peak Reverse Gate Voltage		V_{RGM}	15	V
Storage Temperature Range		T_{stg}	-40~125	$^{\circ}C$
Operating Junction Temperature Range		T_j	-40~125	$^{\circ}C$
Mounting Force		-	500 \pm 50	kg

Note 1 : $V_D=1/2$ Rated, $V_{DM}=2/3$ Rated, $C_S=1\mu F$, $P_S=20\Omega$, $diRG/dt=12A/\mu s$

$I_{RG} \leq 0.5A$, $T_j=125^{\circ}C$, ($V_{Dsp} \leq 400V$)

Note 2 : Half Sine Waveform, $T_f=70^{\circ}C$

Note 3 : $V_D=1/2$ Rated, $I_{TM}=400A$, $I_G=7A$, $t_r=1\mu s$, $f=50Hz$, $T_j=125^{\circ}C$

Note 4 : Pulse Width : Max. 20 μs , Duty : Max. 20%

Note 5 : Pulse Width : Max. 20 μs , Duty : Max. 2%

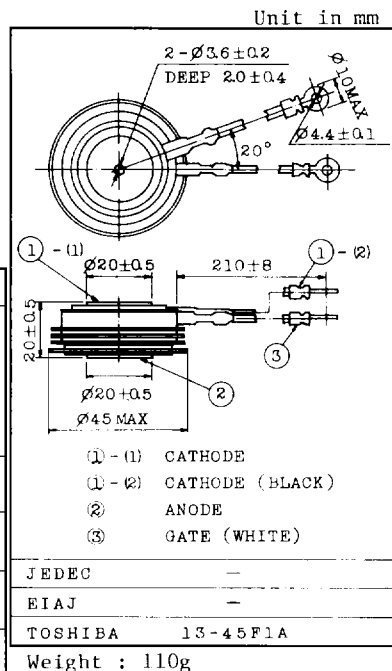

ELECTRICAL CHARACTERISTICS

CHARACTERISTIC		SYMBOL	TEST CONDITION	MIN.	TYP.	MAX.	UNIT	
Repetitive Peak Off-State Current		I_{DRM}	$V_{DRM}=\text{Rated}$, $R_{GK}=20\Omega$ $T_j=125^\circ\text{C}$	-	-	10	mA	
Repetitive Peak Reverse Current		I_{RRM}	$V_{RRM}=\text{Rated}$, $T_j=125^\circ\text{C}$	-	-	10	mA	
Repetitive Peak Reverse Gate Current		I_{RGM}	$V_{RGM}=\text{Rated}$, $T_j=125^\circ\text{C}$	-	-	10	mA	
Peak On-State Voltage		V_{TM}	$I_{TM}=400\text{A}$, $T_c=25^\circ\text{C}$	-	-	2.5	V	
Gate Trigger Voltage		V_{GT}	$V_D=12\text{V}$ $R_L=0.5\Omega$	$T_c=-40^\circ\text{C}$	-	-	1.5	V
				$T_c=25^\circ\text{C}$	-	0.75	1.0	
Gate Trigger Current		I_{GT}		$T_c=-40^\circ\text{C}$	-	-	1500	mA
				$T_c=25^\circ\text{C}$	-	200	500	
Gate Non-Trigger Voltage		V_{GD}	$V_D=1/2 \text{ Rated}$, $T_c=125^\circ\text{C}$	0.3	-	-	V	
Gate Non-Trigger Current		I_{GD}		5	-	-	mA	
Delay Time		t_d	$V_D=1/2 \text{ Rated}$ $di/dt=200\text{A}/\mu\text{s}$ $I_{TM}=400\text{A}$, $I_G=7\text{A}$ $t_r=1\mu\text{s}$, $T_c=25^\circ\text{C}$	-	-	2.0	μs	
Turn-On Time	SG400R22	t_{gt}		-	-	7.6	μs	
	SG400U22			-	-	7.0		
	SG400W22			-	-	6.8		
	SG400EX22			-	-	6.0		
Critical Rate of Rise of Off-State Voltage		dv/dt	$V_{DRM}=2/3 \text{ Rated}$ $T_j=125^\circ\text{C}$, $V_{GK}=-2\text{V}$ Exponential Rise	600	-	-	V/ μs	
Holding Current		I_H	$T_c=25^\circ\text{C}$, $R_L=0.5\Omega$	-	10	-	A	
Storage Time		t_s	$I_T=400\text{A}$ $V_D=1/2 \text{ Rated}$ $V_{DM}=2/3 \text{ Rated}$ $CS=1\mu\text{F}$ $di_{RG}/dt=-12\text{A}/\mu\text{s}$ $T_c=120^\circ\text{C}$	-	-	13	μs	
Gate Turn-Off Time		t_{gq}		-	-	15	μs	
Tail Time	SG400R22	t_{tail}		-	-	62	μs	
	SG400U22		-	-	58			
	SG400W22		-	-	56			
	SG400EX22		-	-	50			
Turn-Off Gate Current		I_{RG}		-	95	125	A	
Thermal Resistance		$R_{th(j-f)}$	Junction to Fine	-	-	0.12	$^\circ\text{C}/\text{W}$	

SG400(R,U,W,EX)22

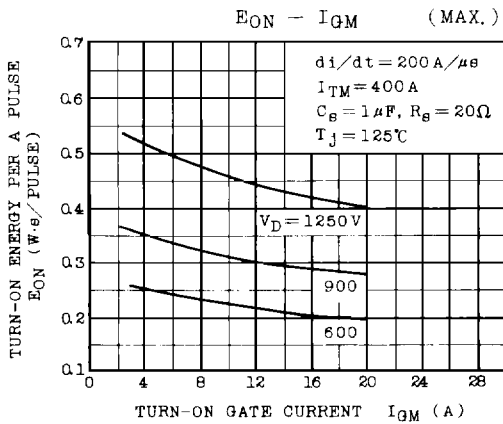
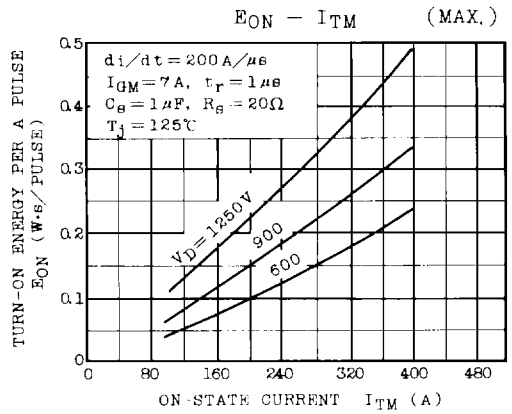
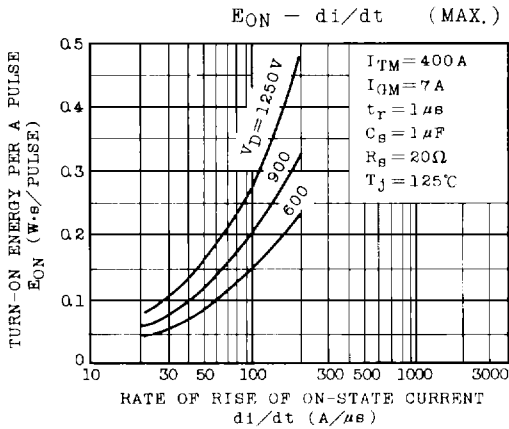
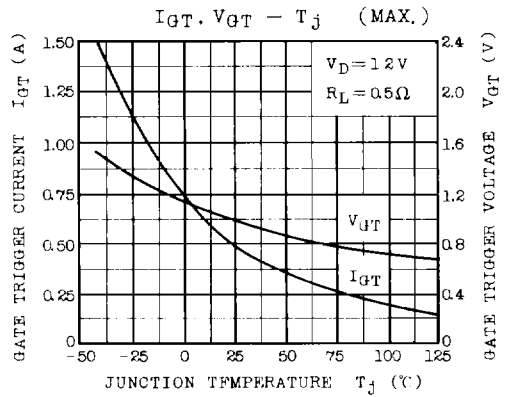
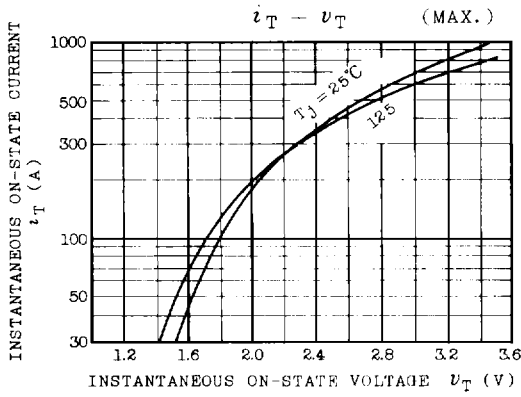

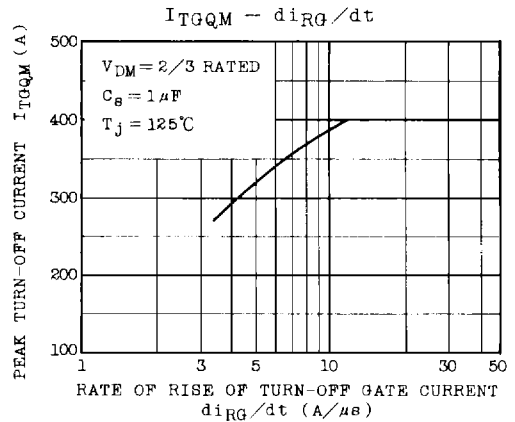
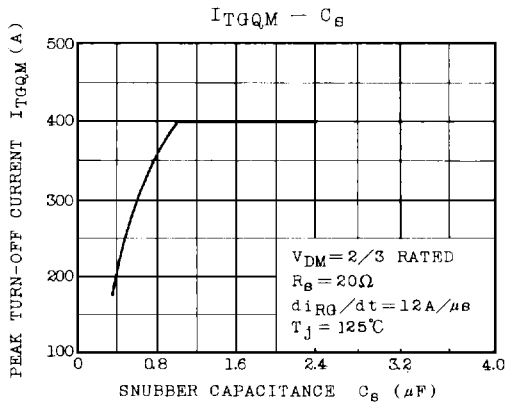
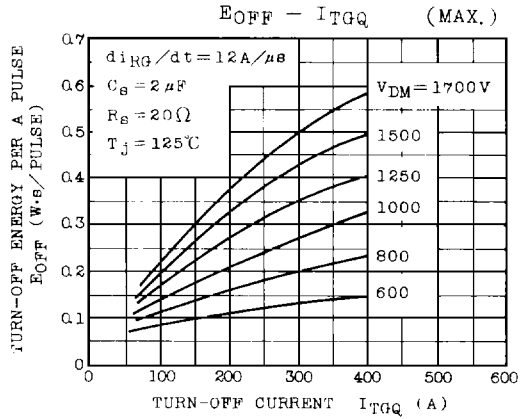
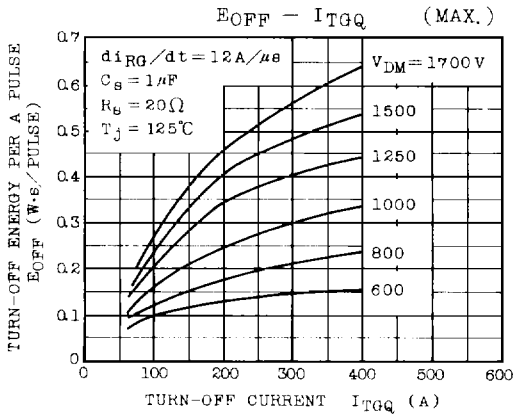
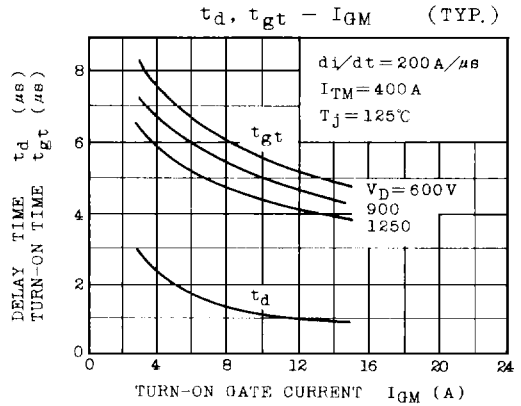
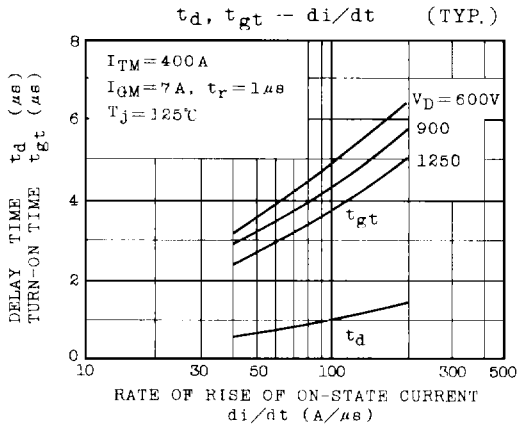

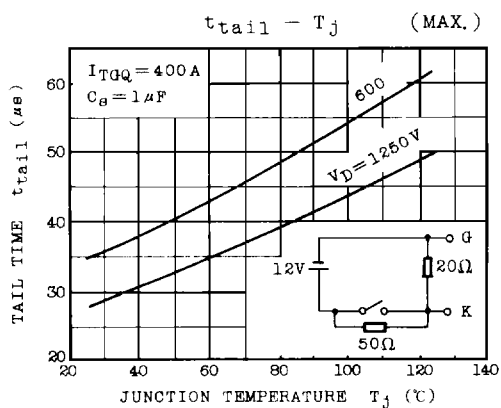
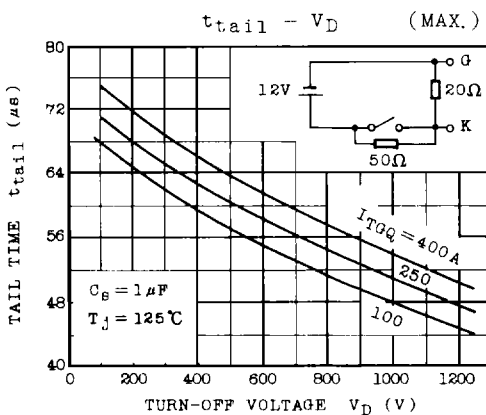
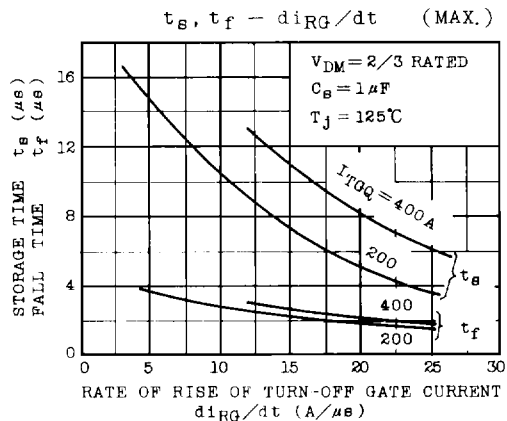
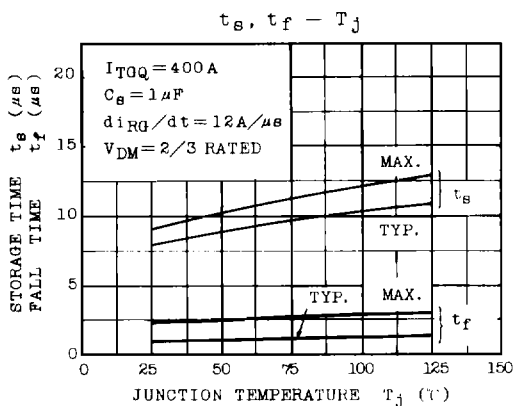
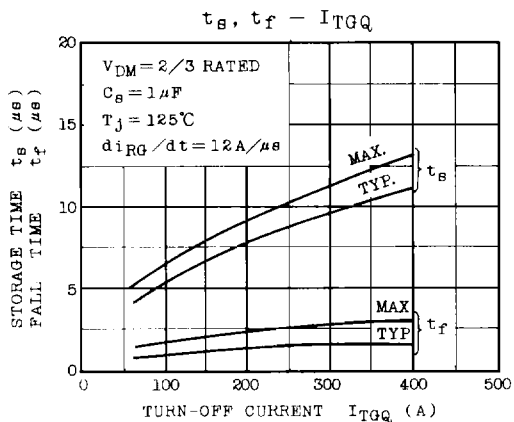
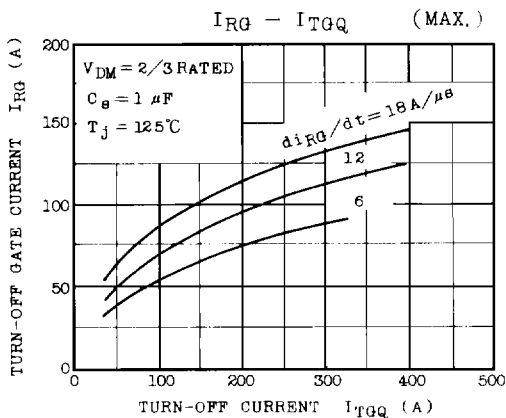

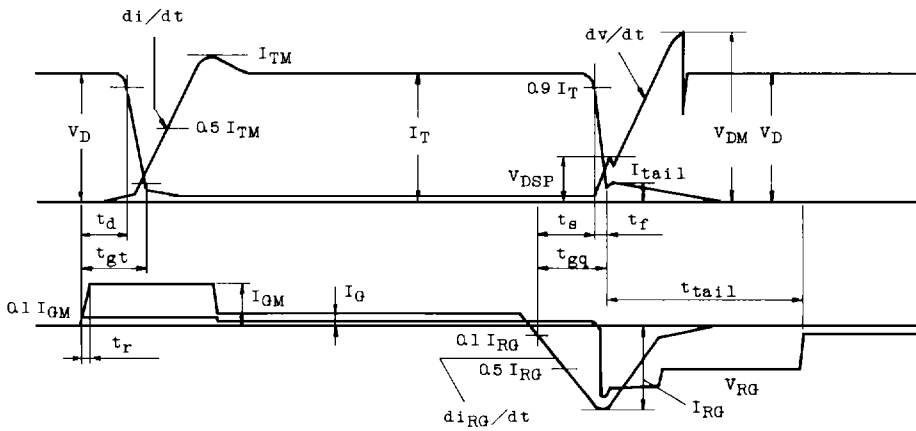
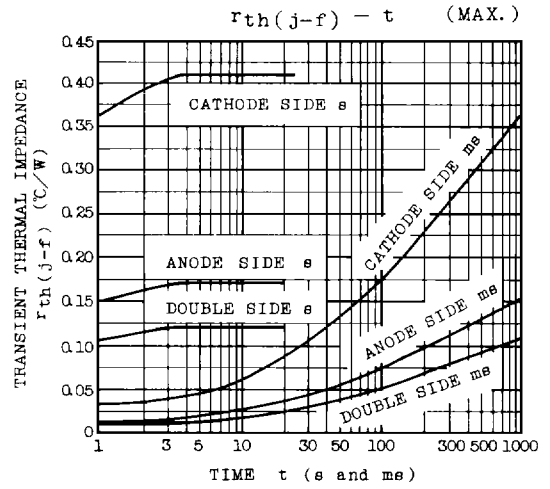
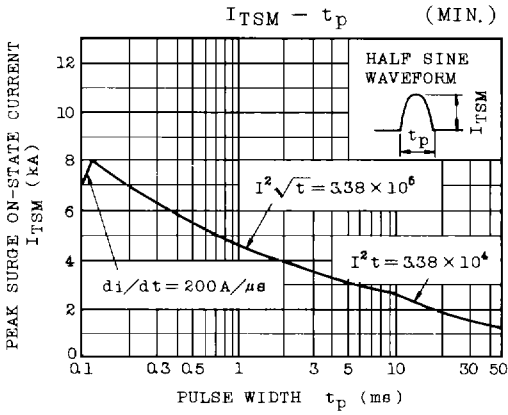

Fig. 1 TURN-ON AND TURN-OFF CHARACTERISTIC OF GTO