



T-51-10-12

TC7109  
TC7109A

2

12-BIT  $\mu$ P-COMPATIBLE ANALOG-TO-DIGITAL CONVERTERS

FEATURES

- Zero-Integrator Cycle for Fast Recovery From Input Overloads
- Eliminates Cross Talk In Multiplexed Systems
- 12-Bit Plus Sign Integrating A/D Converter With Overrange Indication
- Sign Magnitude Coding Format
- True Differential Signal Input and Differential Reference Input
- Low Noise ..... 15  $\mu$ V<sub>p-p</sub> Typ
- High Normal Mode Noise and Line Frequency Rejection
- Input Current ..... 1 pA Typ
- No Zero Adjustment
- TTL-Compatible, Byte-Organized Tri-State Outputs
- UART Handshake Mode for Simple Serial Data Transmission
- Power Dissipation ..... Less Than 20 mW Typ
- Internal Voltage Reference

GENERAL DESCRIPTION

The TC7109A is a 12-bit plus sign, CMOS low-power analog-to-digital converter (ADC). Only eight passive components and a crystal are required to form a complete dual-slope integrating ADC.

The improved  $V_{OH}$  source current TC7109A has features that make it an attractive per-channel alternative to analog multiplexing for many data acquisition applications. These features include typical input bias current of 1 pA, drift of less than 1  $\mu$ V/ $^{\circ}$ C, input noise typically 15  $\mu$ V<sub>p-p</sub>, and auto-zero. True differential input and reference allow measurement of bridge-type transducers such as load cells, strain gauges, and temperature transducers.

The TC7109A provides a versatile digital interface. In the direct mode, chip select and high/low byte enables control parallel bus interface. In the handshake mode, the TC7109A will operate with industry-standard UARTs in controlling serial data transmission — ideal for remote data logging. Control and monitoring of conversion timing is provided by the RUN/HOLD input and STATUS output.

For applications requiring more resolution, see the TC500, 15-bit plus sign ADC data sheet.

The TC7109A has improved overrange recovery performance and higher output drive capability than the original TC7109. All new (or existing) designs should specify the TC7109A wherever possible.

FUNCTIONAL DIAGRAM

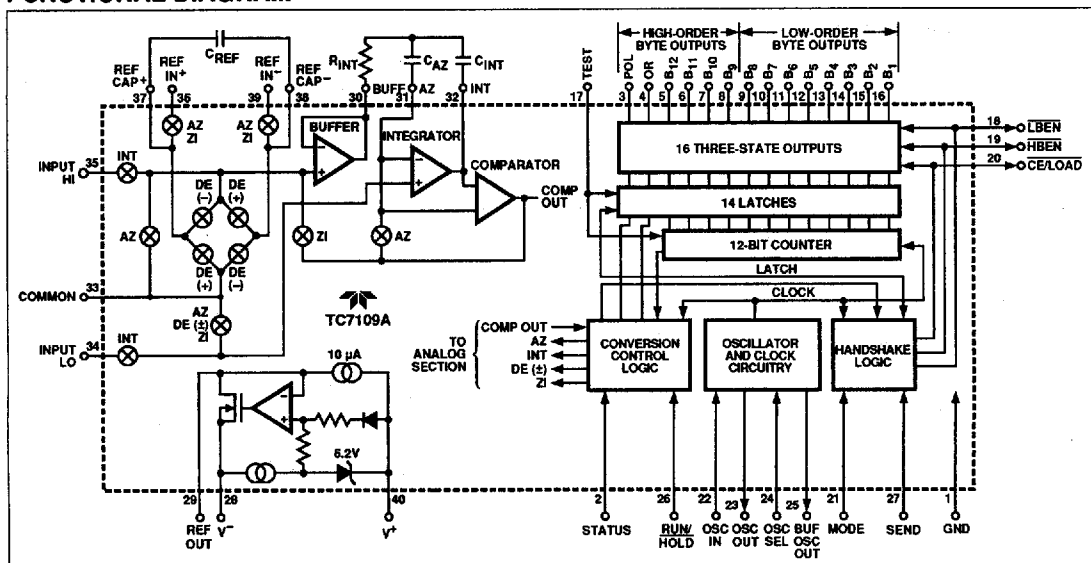

T-51-10-12

12-BIT  $\mu$ P-COMPATIBLE  
ANALOG-TO-DIGITAL CONVERTERS

TC7109  
TC7109A

ORDERING INFORMATION

Part No.	Package	Temperature Range	Part No.	Package	Temperature Range
TC7109ACPL ✓	40-Pin Plastic DIP	0°C to +70°C	TC7109CPL	40-Pin Plastic DIP	0°C to +70°C
TC7109ACKW ~	44-Pin Flat	0°C to +70°C	TC7109CKW	44-Pin Flat	0°C to +70°C
TC7109ACLW ✓	44-Pin PLCC	0°C to +70°C	TC7109CLW	44-Pin PLCC	0°C to +70°C
TC7109AJL	40-Pin CerDIP	-25°C to +85°C	TC7109JL ~	40-Pin CerDIP	-25°C to +85°C
TC7109AMJL	40-Pin CerDIP	-55°C to +125°C	TC7109MJL	40-Pin CerDIP	-55°C to +125°C

PIN CONFIGURATIONS

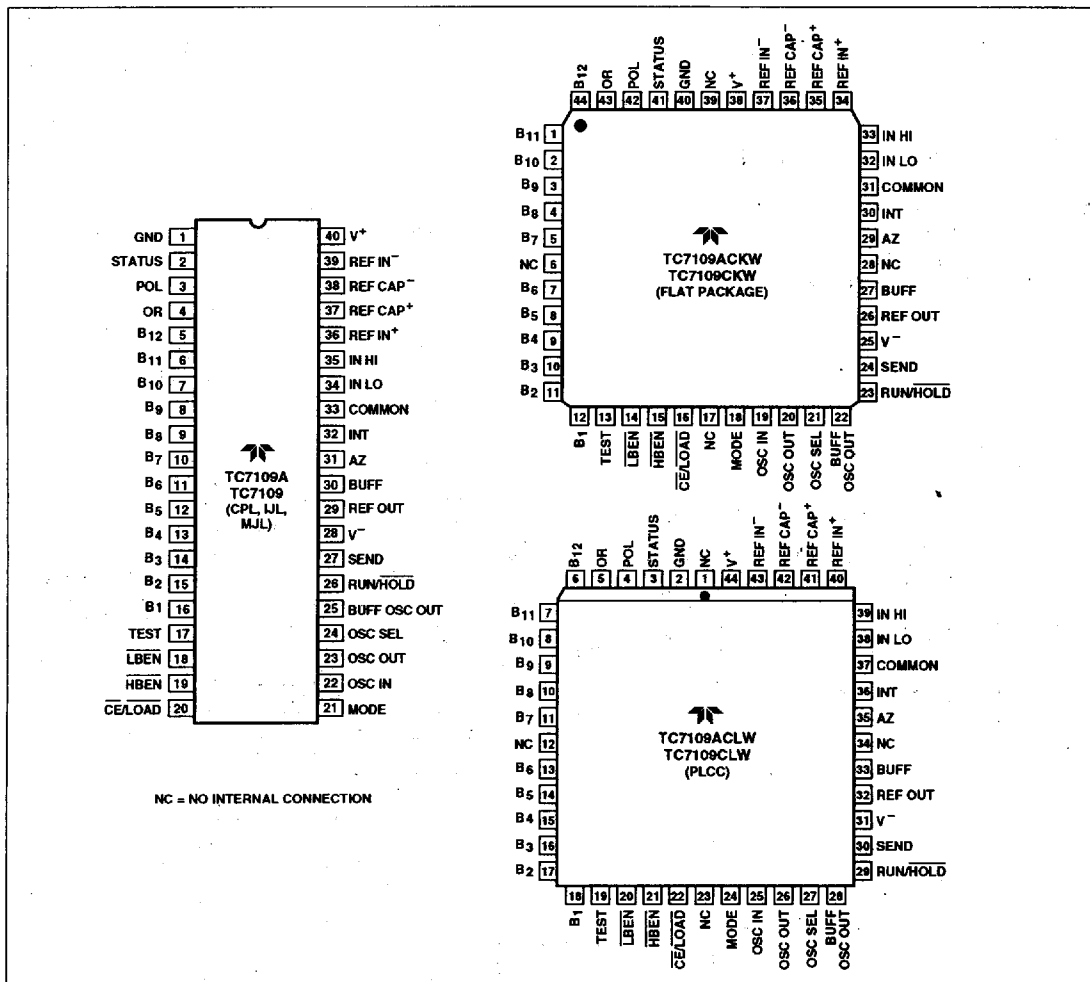

T-51-10-12

## 12-BIT $\mu$ P-COMPATIBLE ANALOG-TO-DIGITAL CONVERTERS

TC7109  
TC7109A

2

### ABSOLUTE MAXIMUM RATINGS

Positive Supply Voltage (GND to $V^+$ )	+6.2V
Negative Supply Voltage (GND to $V^-$ )	-9V
Analog Input Voltage (Low to High) (Note 1)	$V^+$ to $V^-$
Reference Input Voltage (Low to High) (Note 1)	$V^+$ to $V^-$
Digital Input Voltage (Pins 2-27) (Note 2)	GND -0.3V
Power Dissipation (Note 3)	
Ceramic Package	1W at +85°C
Plastic Package	500 mW at +70°C
Operating Temperature Range	
Plastic Package (C)	0°C to +70°C
Ceramic Package (I)	-25°C to +85°C
(M)	-55°C to +125°C
Storage Temperature Range	-65°C to +150°C
Lead Temperature (Soldering, 60 sec)	+300°C

Static-sensitive device. Unused devices must be stored in conductive material. Protect devices from static discharge and static fields. Stresses above those listed under Absolute Maximum Ratings may cause permanent damage to the device. These are stress ratings only and functional operation of the device at these or any other conditions above those indicated in the operational sections of the specifications is not implied. Exposure to Absolute Maximum Rating Conditions for extended periods may affect device reliability.

- NOTES: 1. Input voltages may exceed supply voltages if input current is limited to  $\pm 100 \mu\text{A}$ .
2. Connecting any digital inputs or outputs to voltages greater than  $V^+$  or less than GND may cause destructive device latch-up. Therefore, it is recommended that inputs from sources other than the same power supply should not be applied to the TC7109A before its power supply is established. In multiple supply systems, the supply to the device should be

**ELECTRICAL CHARACTERISTICS:** All parameters with  $V^+ = +5\text{V}$ ,  $V^- = -5\text{V}$ , GND = 0V,  $T_A = +25^\circ\text{C}$ , unless otherwise indicated.

Symbol	Parameter	Test Conditions	Min	Typ	Max	Unit
<b>Analog</b>						
	Overload Recovery Time (TC7109A)			0	1	Measurement Cycle
	Zero Input Reading	$V_{IN} = 0\text{V}$ Full Scale = 409.6 mV	-0000 <sub>8</sub>	$\pm 0000_8$	+0000 <sub>8</sub>	Octal Reading
	Ratiometric Reading	$V_{IN} = V_{REF}$ $V_{REF} = 204.8 \text{ mV}$	3777 <sub>8</sub>	3777 <sub>8</sub> 4000 <sub>8</sub>	4000 <sub>8</sub>	Octal Reading
NL	Nonlinearity (Max Deviation From Best Straight Line Fit)	Full Scale = 409.6 mV to 2.048V Over Full Operating Temperature Range	-1	$\pm 0.2$	+1	Count
	Roll-Over Error (Difference in Reading for Equal Positive and Negative Inputs Near (Full Scale)	Full Scale = 409.6 mV to 2.048V Over Full Operating Temperature Range	-1	$\pm 0.02$	+1	Count
CMRR	Input Common-Mode Rejection Ratio	$V_{CM} \pm 1\text{V}$ , $V_{IN} = 0\text{V}$ Full Scale = 409.6 mV		50		$\mu\text{V/V}$
$V_{CMR}$	Common-Mode Voltage Range	Input High, Input Low, and Common Pins	$V^- + 1.5$		$V^+ - 1$	V
$e_N$	Noise (P-P Value Not Exceeded 95% of Time)	$V_{IN} = 0\text{V}$ Full Scale = 409.6 mV		15		$\mu\text{V}$
$I_{IN}$	Leakage Current at Input	$V_{IN}$ , All Packages: +25°C C Device: 0°C $\nabla$ $T_A$ $\nabla$ +70°C I Device: -25°C $\nabla$ $T_A$ $\nabla$ +85°C M Device: -55°C $\nabla$ $T_A$ $\nabla$ +125°C		1 20 100 2	10 100 250 5	pA pA pA nA
TC <sub>ZS</sub>	Zero Reading Drift	$V_{IN} = 0\text{V}$		0.2	1	$\mu\text{V}/^\circ\text{C}$
TC <sub>FS</sub>	Scale-Factor Temperature Coefficient	$V_{IN} = 408.9 \text{ mV} = > 7770_8$ Reading, Ext Ref = 0 ppm/ $^\circ\text{C}$		1	5	$\mu\text{V}/^\circ\text{C}$
$I^*$	Supply Current ( $V^+$ to GND)	$V_{IN} = 0\text{V}$ , Crystal Oscillator 3.58 MHz Test Circuit		700	1500	$\mu\text{A}$
$I_S$	Supply Current ( $V^+$ to $V^-$ )	Pins 2-21, 25, 26, 27, 29 Open		700	1500	$\mu\text{A}$

T-51-10-12

12-BIT  $\mu$ P-COMPATIBLE  
ANALOG-TO-DIGITAL CONVERTERSTC7109  
TC7109A

## ELECTRICAL CHARACTERISTICS (Cont.)

Symbol	Parameter	Test Conditions	Min	Typ	Max	Unit
$V_{REF}$	Ref Out Voltage	Referenced to $V^+$ , 25 k $\Omega$ Between $V^+$ and Ref Out	-2.4	-2.8	-3.2	V
$TC_{REF}$	Ref Out Temperature Coefficient	25 k $\Omega$ Between $V^+$ and Ref Out 0°C $\pm$ $T_A$ $\pm$ +70°C		80		ppm/°C
<b>Digital</b>						
$V_{OH}$	Output High Voltage	TC7109: $I_{OUT} = 100 \mu A$ TC7109A: $I_{OUT} = 700 \mu A$ Pins 2-16, 18, 19, 20	3.5	4.3		V
$V_{OL}$	Output Low Voltage	$I_{OUT} = 1.6 \text{ mA}$		0.2	0.4	V
	Output Leakage Current	Pins 3-16 High Impedance		$\pm 0.01$	$\pm 1$	$\mu A$
	Control I/O Pull-Up Current	Pins 18, 19, 20 $V_{OUT} = V^+ - 3V$ Mode Input at GND		5		$\mu A$
	Control I/O Loading	HBEN, Pin 19; LBEN, Pin 18			50	pF
$V_{IH}$	Input High Voltage	Pins 18-21, 26, 27 Referenced to GND	2.5			V
$V_{IL}$	Input Low Voltage	Pins 18-21, 26, 27 Referenced to GND			1	V
	Input Pull-Up Current	Pins 26, 27; $V_{OUT} = V^+ - 3V$ Pins 17, 24; $V_{OUT} = V^+ - 3V$		5 25		$\mu A$ $\mu A$
	Input Pull-Down Current	Pin 21; $V_{OUT} = GND = +3V$		1		$\mu A$
	Oscillator Output Current, High	$V_{OUT} = 2.5V$		1		mA
	Oscillator Output Current, Low	$V_{OUT} = 2.5V$		1.5		mA
	Buffered Oscillator Output Current, High	$V_{OUT} = 2.5V$		2		mA
	Buffered Oscillator Output Current, Low	$V_{OUT} = 2.5V$		5		mA
$t_w$	Mode Input Pulse Width		60			ns

**HANDLING PRECAUTIONS:** These devices are CMOS and must be handled correctly to prevent damage. Package and store only in conductive foam, anti-static tubes, or other conducting material. Use proper anti-static handling procedures. Do not connect in circuits under "power-on" conditions, as high transients may cause permanent damage.

## 12-BIT $\mu$ P-COMPATIBLE ANALOG-TO-DIGITAL CONVERTERS

TC7109  
TC7109A

2

### PIN DESCRIPTION

40-Pin DIP Pin Number	Name	Description
1	GND	Digital ground, 0V, ground return for all digital logic.
2	STATUS	Output high during integrate and deintegrate until data is latched. Output low when analog section is in auto-zero or zero-integrator configuration.
3	POL	Polarity — High for positive input.
4	OR	Overrange — High if overranged.
5	B <sub>12</sub>	Bit 12 (Most Significant Bit)
6	B <sub>11</sub>	Bit 11
7	B <sub>10</sub>	Bit 10
8	B <sub>9</sub>	Bit 9
9	B <sub>8</sub>	Bit 8
10	B <sub>7</sub>	Bit 7
11	B <sub>6</sub>	Bit 6
12	B <sub>5</sub>	Bit 5
13	B <sub>4</sub>	Bit 4
14	B <sub>3</sub>	Bit 3
15	B <sub>2</sub>	Bit 2
16	B <sub>1</sub>	Bit 1 (Least Significant Bit)
17	TEST	Input High — Normal operation. Input Low — Forces all bit outputs high. <b>Note:</b> This input is used for test purposes only.
18	LBEN	Low-Byte Enable — With MODE (Pin 21) low, and $\overline{\text{CE/LOAD}}$ (Pin 20) low, taking this pin low activates low-order byte outputs, B1–B8. With MODE (Pin 21) high, this pin serves as low-byte flag output used in handshake mode. See Figures 7, 8, and 9.
19	HBEN	High-Byte Enable — With MODE (Pin 21) low, and $\overline{\text{CE/LOAD}}$ (Pin 20) low, taking this pin low activates high-order byte outputs, B9–B12, POL, OR. With MODE (Pin 21) high, this pin serves as high-byte flag output used in handshake mode. See Figures 7, 8, and 9.
20	$\overline{\text{CE/LOAD}}$	Chip Enable/Load — With MODE (Pin 21) low, $\overline{\text{CE/LOAD}}$ serves as a master output enable. When high, B1–B12, POL, OR outputs are disabled. When MODE (Pin 21) is high, a load strobe is used in handshake mode. See Figure 7, 8, and 9.
21	MODE	Input Low — Direct output mode where $\overline{\text{CE/LOAD}}$ (Pin 20), HBEN (Pin 19), and LBEN (Pin 18) act as inputs directly controlling byte outputs. Input Pulsed High — Causes immediate entry into handshake mode and output of data as in Figure 9. Input High — Enables $\overline{\text{CE/LOAD}}$ (Pin 20), HBEN (Pin 19), and LBEN (Pin 18) as outputs; handshake mode will be entered and data output as in Figures 7 and 8 at conversions completion.
22	OSC IN	Oscillator Input
23	OSC OUT	Oscillator Output
24	OSC SEL	Oscillator Select — Input high configures OSC IN, OSC OUT, BUF OSC OUT as RC oscillator — clock will be same phase and duty cycle as BUF OSC OUT. Input low configures OSC IN, OSC OUT for crystal oscillator — clock frequency will be 1/58 of frequency at BUF OSC OUT.
25	BUF OSC OUT	Buffered Oscillator Output
26	RUN/HOLD	Input High — Conversions continuously performed every 8192 clock pulses. Input Low — Conversion in progress completed; converter will stop in auto-zero seven counts before integrate.
27	SEND	Input — Used in handshake mode to indicate ability of an external device to accept data. Connect to V <sub>+</sub> if not used.
28	V <sup>-</sup>	Analog Negative Supply — Nominally -5V with respect to GND (Pin 1).
29	REF OUT	Reference Voltage Output — Nominally 2.8V down from V <sup>+</sup> (Pin 40).

All Three-State Data Bits

T-51-10-12

12-BIT  $\mu$ P-COMPATIBLE  
ANALOG-TO-DIGITAL CONVERTERSTC7109  
TC7109A

## PIN DESCRIPTION (Cont.)

40-Pin DIP		
Pin Number	Name	Description
30	BUFFER	Buffer Amplifier Output
31	AUTO-ZERO	Auto-Zero Node — Inside foil of C <sub>AZ</sub> .
32	INTEGRATOR	Integrator Output — Outside foil of C <sub>INT</sub> .
33	COMMON	Analog Common — System is auto-zeroed to COMMON.
34	INPUT LOW	Differential Input Low Side
35	INPUT HIGH	Differential Input High Side
36	REF IN +	Differential Reference Input Positive
37	REF CAP +	Reference Capacitor Positive
38	REF CAP -	Reference Capacitor Negative
39	REF IN -	Differential Reference Input Negative
40	V <sup>+</sup>	Positive Supply Voltage — Nominally +5V with respect to GND (Pin 1).

NOTE: All digital levels are positive true.

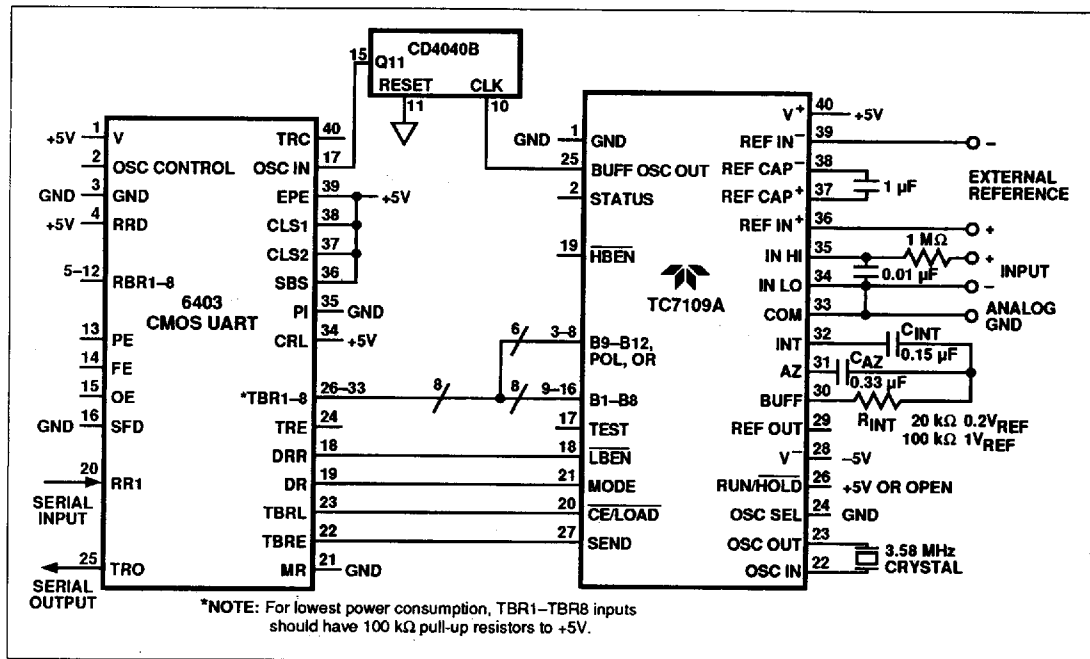

Figure 1 TC7109A UART Interface (Send Any Word to UART to Transmit Latest Result)

T-51-10-12

## 12-BIT $\mu$ P-COMPATIBLE ANALOG-TO-DIGITAL CONVERTERS

TC7109  
TC7109A

2

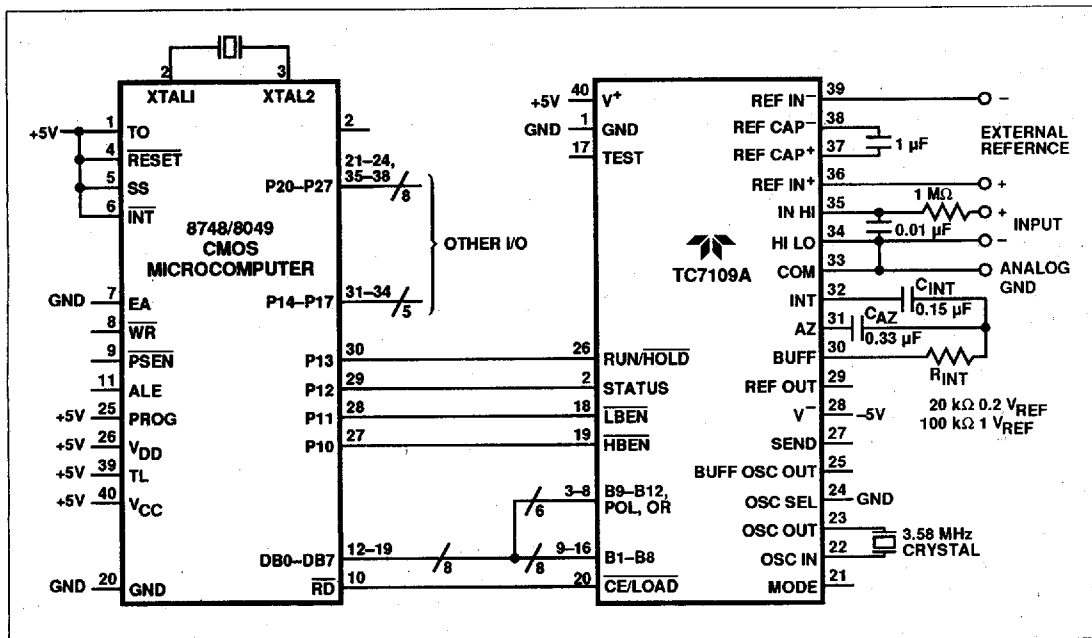

Figure 2 TC7109A Parallel Interface With 8048/8049 Microcomputer

### DETAILED DESCRIPTION

#### Analog Section

The functional diagram shows a block diagram of the analog section of the TC7109A. The circuit will perform conversions at a rate determined by the clock frequency (8192 clock periods per cycle), when the RUN/HOLD input is left open or connected to  $V^+$ . Each measurement cycle is divided into four phases, as shown in Figure 3. They are: (1) Auto-Zero (AZ), (2) Signal Integrate (INT), (3) Reference Deintegrate (DE), and (4) Zero Integrator (ZI).

#### Auto-Zero Phase

The buffer and the integrator inputs are disconnected from input high and input low and connected to analog common. The reference capacitor is charged to the reference voltage. A feedback loop is closed around the system to charge the auto-zero capacitor,  $C_{AZ}$ , to compensate for offset voltage in the buffer amplifier, integrator, and comparator. Since the comparator is included in the loop, the AZ accuracy is limited only by the noise of the system. The offset referred to the input is less than  $10 \mu V$ .

#### Signal-Integrate Phase

The buffer and integrator inputs are removed from common and connected to input high and input low. The auto-zero loop is opened. The auto-zero capacitor is placed in series in the loop to provide an equal and opposite compensating offset voltage. The differential voltage between input high and input low is integrated for a fixed time of 2048 clock periods. At the end of this phase, the polarity of the integrated signal is determined. If the input signal has no return to the converter's power supply, input low can be tied to analog common to establish the correct common-mode voltage.

#### Deintegrate Phase

Input high is connected across the previously-charged reference capacitor and input low is internally connected to analog common. Circuitry within the chip ensures the capacitor will be connected with the correct polarity to cause the integrator output to return to the zero crossing (established by auto-zero) with a fixed slope. The time, represented by the number of clock periods counted for the output to return to zero, is proportional to the input signal.

T-51-10-12

12-BIT  $\mu$ P-COMPATIBLE  
ANALOG-TO-DIGITAL CONVERTERSTC7109  
TC7109A**Zero-Integrator Phase**

The ZI phase only occurs when an input overrange condition exists. The function of the ZI phase is to eliminate residual charge on the integrator capacitor after an overrange measurement. Unless removed, the residual charge will be transferred to the auto-zero capacitor and cause an error in the succeeding conversion.

The ZI phase virtually eliminates hysteresis or "cross talk" in multiplexed systems. An overrange input on one channel will not cause an error on the next channel measured. This feature is especially useful in thermocouple measurements, where unused (or broken thermocouple) inputs are pulled to the positive supply rail.

During ZI, the reference capacitor is charged to the reference voltage. The signal inputs are disconnected from the buffer and integrator. The comparator output is connected to the buffer input, causing the integrator output to be driven rapidly to 0V (Figure 3). The ZI phase only occurs following an overrange and lasts for a maximum of 1024 clock periods.

**Differential Input**

The TC7109A has been optimized for operation with analog common near digital ground. With +5V and -5V power supplies, a full  $\pm 4V$  full-scale integrator swing maximizes the analog section's performance.

A typical CMRR of 86 dB is achieved for input differential voltages anywhere within the typical common-mode range of 1V below the positive supply to 1.5V above the negative supply. However, for optimum performance the IN HI and IN LO inputs should not come within 2V of either supply rail. Since the integrator also swings with the common-mode voltage, care must be exercised to ensure the integrator output does not saturate. A worst-case condition is near a full-scale negative differential input voltage with a large positive common-mode voltage. The negative input signal drives the integrator positive when most of its swing has been used up by the positive common-mode voltage. In such cases, the integrator swing can be reduced to less than the recommended  $\pm 4V$  full-scale value, with some loss of accuracy. The integrator output can swing to within 0.3V of either supply without loss of linearity.

**Differential Reference**

The reference voltage can be generated anywhere within the power supply voltage of the converter. Roll-over voltage is the main source of common-mode error, caused by the reference capacitor losing or gaining charge due to stray capacity on its nodes. With a large common-mode voltage, the reference capacitor can gain charge (increase voltage) when called upon to deintegrate a positive signal and lose charge (decrease voltage) when called upon to deintegrate a negative input signal. This difference in

reference for (+) or (-) input voltage will cause a roll-over error. This error can be held to less than 0.5 count worst case by using a large reference capacitor in comparison to the stray capacitance. To minimize roll-over error from these sources, keep the reference common-mode voltage near or at analog common.

**Digital Section**

The digital section is shown in the block diagram (Figure 4) and includes the clock oscillator and scaling circuit, a 12-bit binary counter with output latches and TTL compatible three-state output drivers, UART handshake logic, polarity, overrange, and control logic. Logic levels are referred to as "low" or "high."

Inputs driven from TTL gates should have 3 k $\Omega$  to 5 k $\Omega$  pull-up resistors added for maximum noise immunity. For minimum power consumption, all inputs should swing from GND (low) to V<sup>+</sup> (high).

**STATUS Output**

During a conversion cycle, the STATUS output goes high at the beginning of signal integrate and goes low one-half clock period after new data from the conversion has been stored in the output latches (see Figure 3). The signal may be used as a "data valid" flag to drive interrupts, or for monitoring the status of the converter. (Data will not change while status is low.)

**MODE Input**

The output mode of the converter is controlled by the MODE input. The converter is in its "direct" output mode, when the MODE input is low or left open. The output data is directly accessible under the control of the chip and byte enable inputs (this input is provided with a pull-down resistor to ensure a low level when the pin is left open). When the MODE input is pulsed high, the converter enters the UART handshake mode and outputs the data in 2 bytes, then returns to "direct" mode. When the MODE input is kept high, the converter will output data in the handshake mode at the end of every conversion cycle. With MODE = 0 (direct bus transfer), the send input should be tied to V<sup>+</sup>. (See "Handshake Mode.")

**RUN/HOLD Input**

With the RUN/HOLD input high, or open, the circuit operates normally as a dual-slope ADC, as shown in Figure 3. Conversion cycles operate continuously with the output latches updated after zero crossing in the deintegrate mode. An internal pull-up resistor is provided to ensure a high level with an open input.

T-51-10-12

12-BIT  $\mu$ P-COMPATIBLE  
ANALOG-TO-DIGITAL CONVERTERS

TC7109  
TC7109A

2

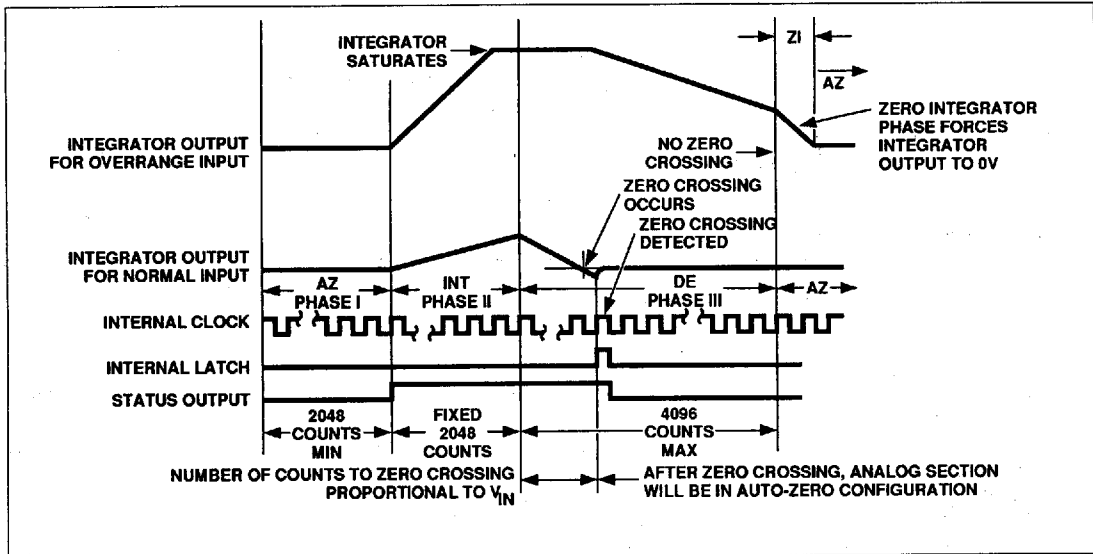

Figure 3 Conversion Timing (RUN/HOLD Pin High)

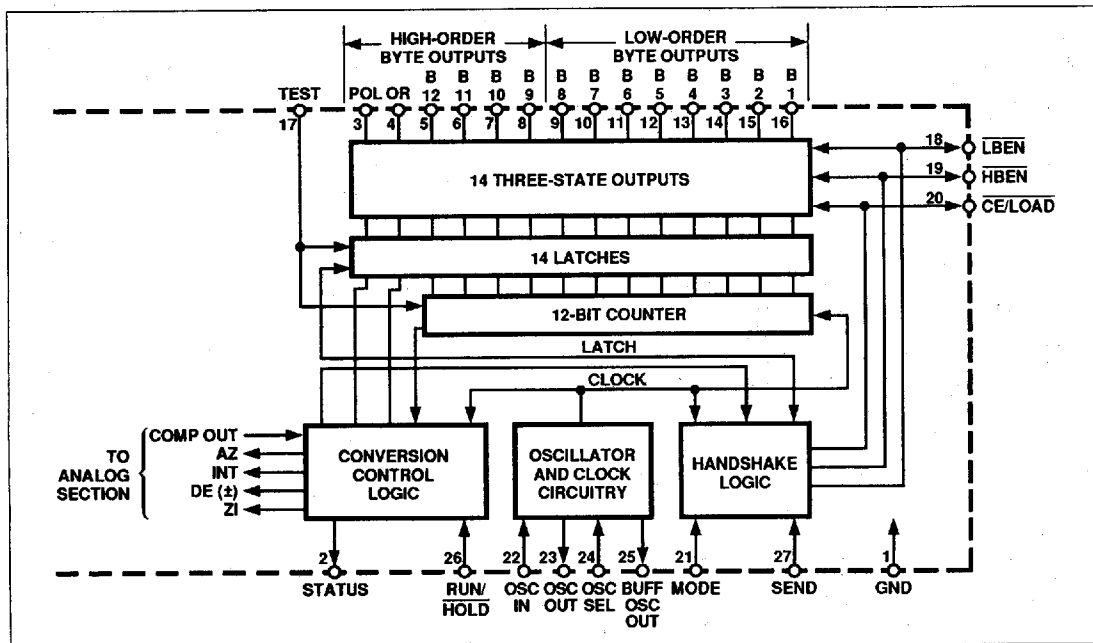

Figure 4 Digital Section

T-51-10-12

12-BIT  $\mu$ P-COMPATIBLE  
ANALOG-TO-DIGITAL CONVERTERSTC7109  
TC7109A

Figure 5 TC7109A RUN/HOLD Operation

The RUN/HOLD input may be used to shorten conversion time. If RUN/HOLD goes low any time after zero crossing in the deintegrate mode, the circuit will jump to auto-zero and eliminate that portion of time normally spent in deintegrate.

If RUN/HOLD stays or goes low, the conversion will complete with minimum time in deintegrate. It will stay in auto-zero for the minimum time and wait in auto-zero for a high at the RUN/HOLD input. As shown in Figure 5, the STATUS output will go high 7 clock periods after RUN/HOLD is changed to high, and the converter will begin the integrate phase of the next conversion.

The RUN/HOLD input allows controlled conversion interface. The converter may be held at idle in auto-zero with RUN/HOLD low. The conversion is started when RUN/HOLD goes high, and the new data is valid when the STATUS output goes low (or is transferred to the UART; see "Handshake Mode"). RUN/HOLD may now go low, terminating deintegrate and ensuring a minimum auto-zero time before stopping to wait for the next conversion. Conversion time can be minimized by ensuring RUN/HOLD goes low during deintegrate, after zero crossing, and goes high after the hold point is reached. The required activity on the RUN/HOLD input can be provided by connecting it to the buffered oscillator output. In this mode, the input value measured determines the conversion time.

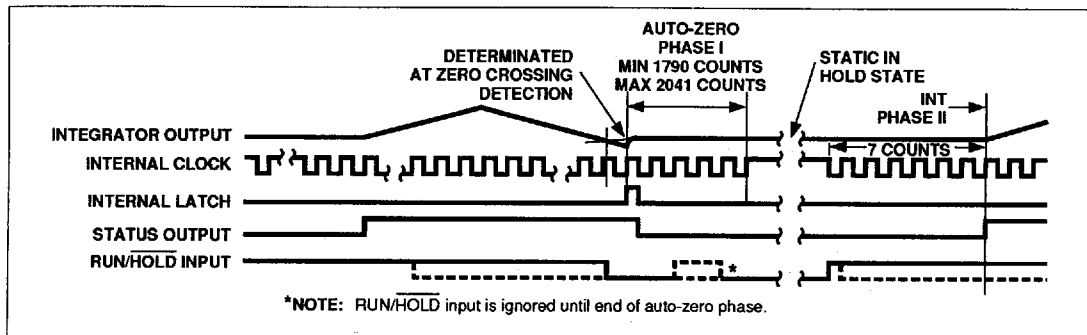
**Direct Mode**

The data outputs (bits 1 through 8, low-order bytes; bits 9 through 12, polarity and overrange high-order bytes) are accessible under control of the byte and chip enable terminals as inputs with the MODE pin at a low level. These three inputs are all active low. Internal pull-up resistors are provided for an inactive high level when left open. When chip enable is low, a byte-enable input low will allow the outputs of the byte to become active. A variety of parallel data

accessing techniques may be used, as shown in the "Interfacing" section. (See Figure 6 and Table I.)

The access of data should be synchronized with the conversion cycle by monitoring the STATUS output. This prevents accessing data while it is being updated and eliminates the acquisition of erroneous data.

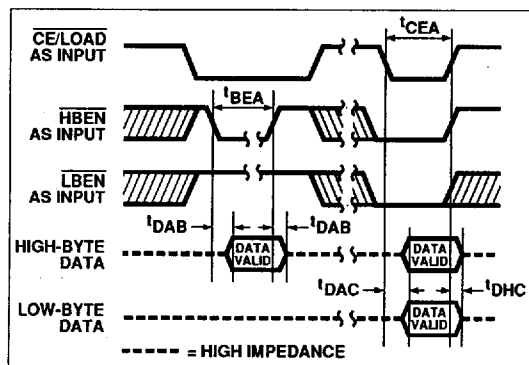

Figure 6 TC7109A Direct Mode Output Timing

Table I TC7109A Direct Mode Timing Requirements

Symbol	Description	Min	Typ	Max	Units
$t_{BEA}$	Byte Enable Width	200	500		ns
$t_{DAB}$	Data Access Time From Byte Enable		150	300	ns
$t_{DHB}$	Data Hold Time From Byte Enable		150	300	ns
$t_{CEA}$	Chip Enable Width	300	500		ns
$t_{DAC}$	Data Access Time From Chip Enable		200	400	ns
$t_{DHC}$	Data Hold Time From Chip Enable		200	400	ns

## 12-BIT $\mu$ P-COMPATIBLE ANALOG-TO-DIGITAL CONVERTERS

T-51-10-12

TC7109  
TC7109A

2

### Handshake Mode

An alternative means of interfacing the TC7109A to digital systems is provided when the handshake output mode of the TC7109A becomes active in controlling the flow of data instead of passively responding to chip and byte enable inputs. This mode allows a direct interface between the TC7109A and industry-standard UARTs with no external logic required. The TC7109A provides all the control and flag signals necessary to sequence the two bytes of data into the UART and initiate their transmission in serial form when triggered into the handshake mode. The cost of designing remote data acquisition stations is reduced using serial data transmission to minimize the number of lines to the central controlling processor.

The MODE input controls the handshake mode. When the MODE input is held high, the TC7109A enters the handshake mode after new data has been stored in the output latches at the end of every conversion performed (see Figures 7 and 8). Entry into the handshake mode may be triggered on demand by the MODE input. At any time during the conversion cycle, the low-to-high transition of a short pulse at the MODE input will cause immediate entry into the handshake mode. If this pulse occurs while new data is being stored, the entry into handshake mode is delayed until the data is stable. The MODE input is ignored in the handshake mode, and until the converter completes the output cycle and clears the handshake mode, data updating will be inhibited (see Figure 9).

When the MODE input is high or when the converter enters the handshake mode, the chip and byte enable inputs become TTL-compatible outputs which provide the output cycle control signals (see Figures 7, 8 and 9).

The SEND input is used by the converter as an indication of the ability of the receiving device (such as a UART) to accept data in the handshake mode. The sequence of the output cycle with SEND held high is shown in Figure 7. The handshake mode (internal MODE high) is entered after the data latch pulse (the  $\overline{\text{CE/LOAD}}$ ,  $\overline{\text{LBEN}}$  and  $\overline{\text{HBEN}}$  terminals are active as outputs since MODE remains high).

The high level at the SEND input is sensed on the same high-to-low internal clock edge. On the next low-to-high internal clock edge, the high-order byte (bits 9 through 12, POL, and OR) outputs are enabled and the  $\overline{\text{CE/LOAD}}$  and the  $\overline{\text{HBEN}}$  outputs assume a low level. The  $\overline{\text{CE/LOAD}}$  output remains low for one full internal clock period only; the data outputs remain active for 1-1/2 internal clock periods; and the high-byte enable remains low for 2 clock periods. The  $\overline{\text{CE/LOAD}}$  output low level or low-to-high edge may be used as a synchronizing signal to ensure valid data, and the byte enable as an output may be used as a byte identification flag. With SEND remaining high the

converter completes the output cycle using  $\overline{\text{CE/LOAD}}$  and  $\overline{\text{LBEN}}$  while the low-order byte outputs (bits 1 through 8) are activated. When both bytes are sent, the handshake mode is terminated. The typical UART interfacing timing is shown in Figure 8. The SEND input is used to delay portions of the sequence, or handshake, to ensure correct data transfer. This timing diagram shows an industry-standard HD6403 or CDP1854 CMOS UART to interface to serial data channels. The SEND input to the TC7109A is driven by the TBRE (Transmitter Buffer Register Empty) output of the UART, and the  $\overline{\text{CE/LOAD}}$  input of the TC7109A drives the TBRL (Transmitter Buffer Register Load) input to the UART. The eight transmitter buffer register inputs accept the parallel data outputs. With the UART transmitter buffer register empty, the SEND input will be high when the handshake mode is entered after new data is stored. The high-order byte outputs become active and the  $\overline{\text{CE/LOAD}}$  and  $\overline{\text{HBEN}}$  inputs will go low after SEND is sensed. When  $\overline{\text{CE/LOAD}}$  goes high at the end of one clock period, the high-order byte data is clocked into the UART transmitter buffer register. The UART TBRE output will go low, which halts the output cycle with the  $\overline{\text{HBEN}}$  output low, and the high-order byte outputs active. When the UART has transferred the data to the transmitter register and cleared the transmitter buffer register, the TBRE returns high. The high-order byte outputs are disabled on the next TC7109A internal clock high-to-low edge, and one-half internal clock later, the  $\overline{\text{HBEN}}$  output returns high. The  $\overline{\text{CE/LOAD}}$  and  $\overline{\text{LBEN}}$  outputs go low at the same time as the low-order byte outputs become active. When the  $\overline{\text{CE/LOAD}}$  returns high at the end of one clock period, the low-order data is clocked into the UART transmitter buffer register, and TBRE again goes low. The next TC7109A internal clock high-to-low edge will sense when TBRE returns to a high, disabling the data inputs. One-half internal clock later, the handshake mode is cleared, and the  $\overline{\text{CE/LOAD}}$ ,  $\overline{\text{HBEN}}$  and  $\overline{\text{LBEN}}$  terminals return high and stay active, if MODE still remains high.

Handshake output sequences may be performed on demand by triggering the converter into handshake mode with a low-to-high edge on the MODE input. A handshake output sequence triggered is shown in Figure 9. The SEND input is low when the converter enters handshake mode. The whole output sequence is controlled by the SEND input, and the sequence for the first (high order) byte is similar to the sequence for the second byte.

Figure 9 also shows that the output sequence can take longer than a conversion cycle. New data will not be latched when the handshake mode is still in progress and is therefore lost.

T-51-10-12

12-BIT  $\mu$ P-COMPATIBLE  
ANALOG-TO-DIGITAL CONVERTERS

TC7109  
TC7109A

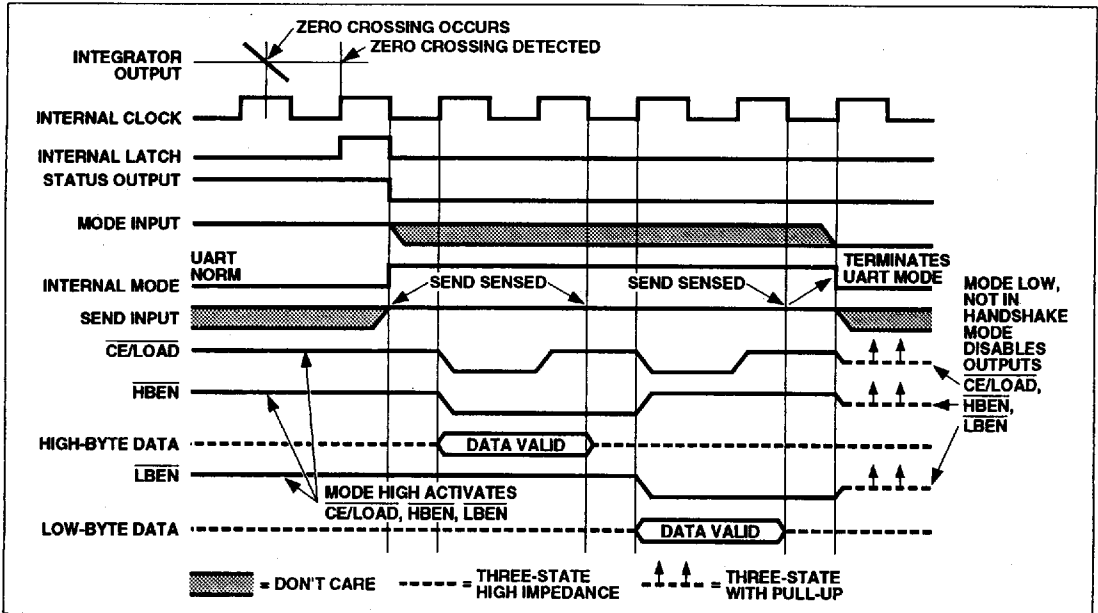

Figure 7 TC7109A Handshake With Send Input Held Positive

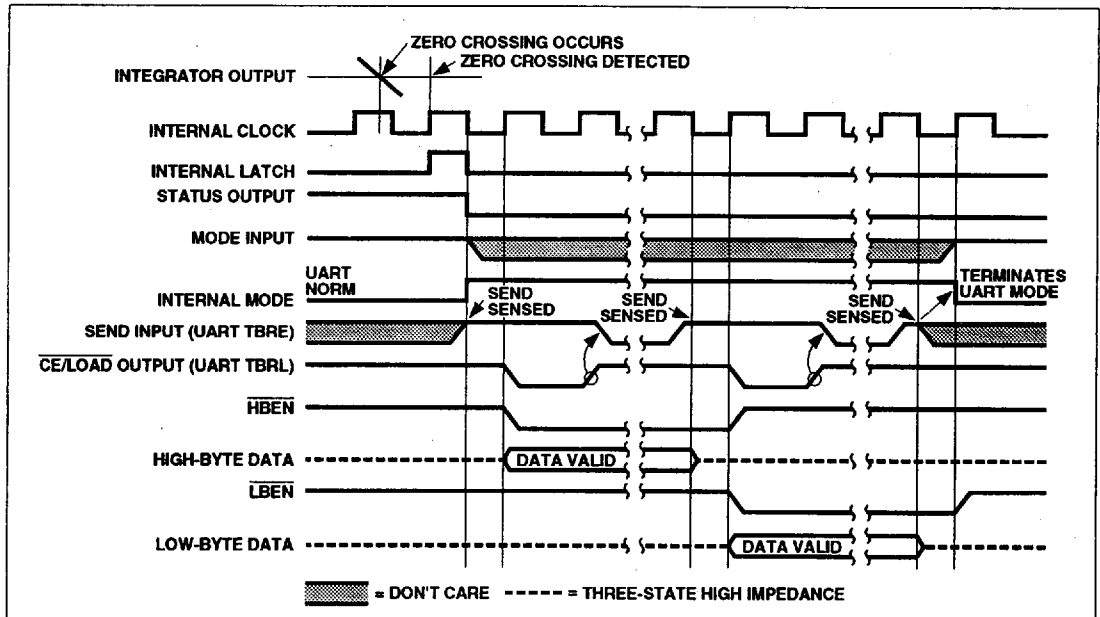

Figure 8 TC7109A Handshake - Typical UART Interface Timing

# 12-BIT $\mu$ P-COMPATIBLE ANALOG-TO-DIGITAL CONVERTERS

T-51-10-12

**TC7109  
TC7109A**

2

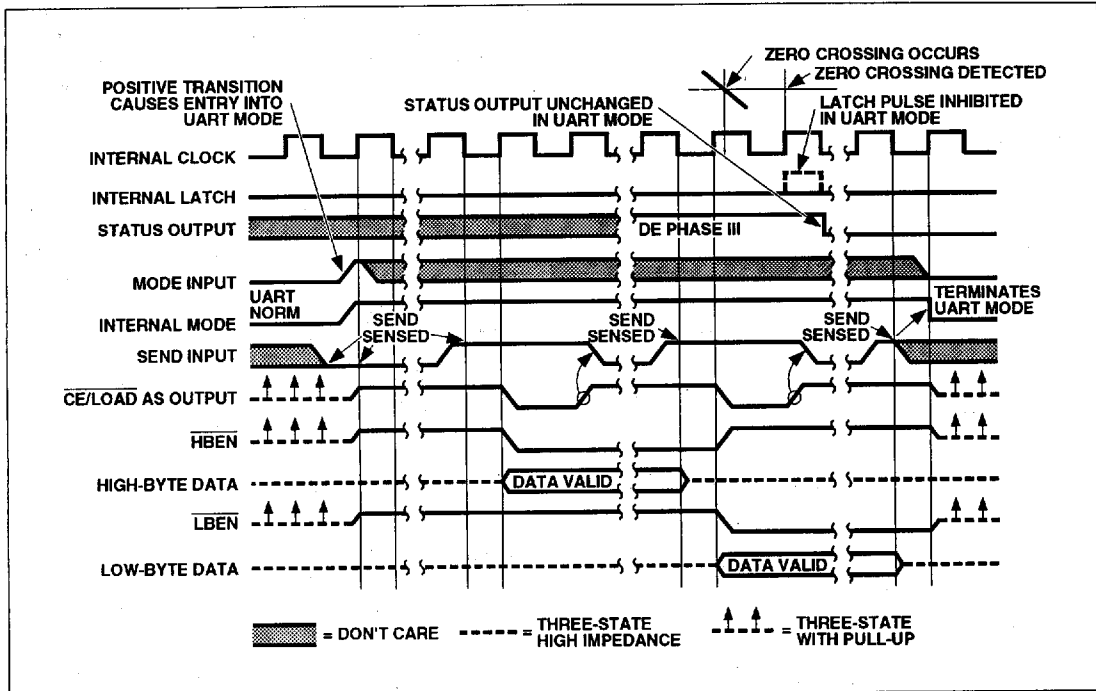

Figure 9 TC7109A Handshake Triggered by MODE Input

## Oscillator

The oscillator may be overdriven, or may be operated as an RC or crystal oscillator. The OSCILLATOR SELECT input optimizes the internal configuration of the oscillator for RC or crystal operation. The OSCILLATOR SELECT input is provided with a pull-up resistor. When the OSCILLATOR SELECT input is high or left open, the oscillator is configured for RC operation. The internal clock will be the same frequency and phase as the signal at the BUFFERED OSCILLATOR OUTPUT. Connect the resistor and capacitor as in Figure 10. The circuit will oscillate at a frequency given by  $f = 0.45/RC$ . A 100 k $\Omega$  resistor is recommended for useful ranges of frequency. The capacitor value should be chosen such that 2048 clock periods are close to an integral multiple of the 60 Hz period for optimum 60 Hz line rejection.

With OSCILLATOR SELECT input low, two on-chip capacitors and a feedback device are added to the oscillator. In this configuration, the oscillator will operate with most crystals in the 1 to 5 MHz range with no external components

(Figure 11). The OSCILLATOR SELECT input low inserts a fixed  $\div 58$  divider circuit between the BUFFERED OSCILLATOR OUTPUT and the internal clock. A 3.58 MHz TV crystal gives a division ratio providing an integration time given by:

$$t = (2048 \text{ clock periods}) \frac{58}{3.58 \text{ MHz}} = 33.18 \text{ ms}$$

The error is less than 1% from two 60 Hz periods, or 33.33 ms, which will give better than 40 dB, 60 Hz rejection. The converter will operate reliably at conversion rates up to 30 per second, corresponding to a clock frequency of 245.8 kHz.

When the oscillator is to be overdriven, the OSCILLATOR OUTPUT should be left open, and the overdriving signal should be applied at the OSCILLATOR INPUT. The internal clock will be of the same duty cycle, frequency and phase as the input signal. When the OSCILLATOR SELECT is at GND, the clock will be 1/58 of the input frequency.

T-51-10-12

## 12-BIT $\mu$ P-COMPATIBLE ANALOG-TO-DIGITAL CONVERTERS

### TC7109 TC7109A

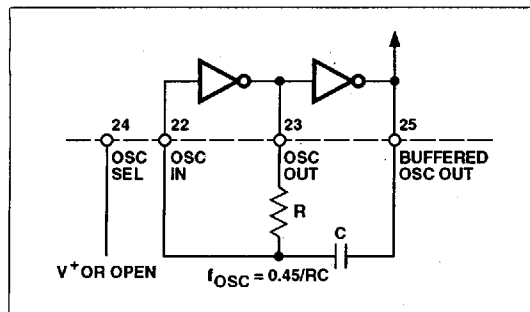

Figure 10 TC7109A RC Oscillator

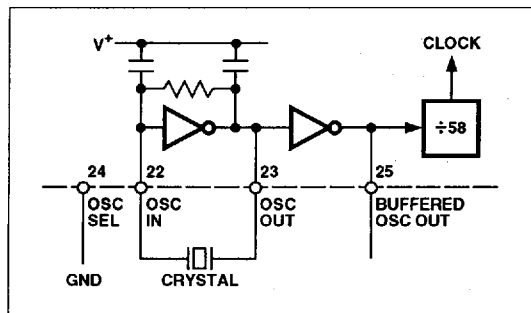

Figure 11 TC7109A Crystal Oscillator

### Test Input

The counter and its outputs may be tested easily. When the TEST input is connected to GND, the internal clock is disabled and the counter outputs are all forced into the high state. When the input returns to the  $1/2 (V^+ - GND)$  voltage or to  $V^+$  and one clock is input, the counter outputs will all be clocked to the low state.

The counter output latches are enabled when the TEST input is taken to a level halfway between  $V^+$  and GND, allowing the counter contents to be examined anytime.

### Component Value Selection

The integrator output swing for full-scale should be as large as possible. For example, with  $\pm 5V$  supplies and COMMON connected to GND, the nominal integrator output swing at full-scale is  $\pm 4V$ . Since the integrator output can go to 0.3V from either supply without significantly effecting linearity, a 4V integrator output swing allows 0.7V for variations in output swing due to component value and oscillator tolerances. With  $\pm 5V$  supplies and a common-mode voltage range of  $\pm 1V$  required, the component values should be selected to provide  $\pm 3V$  integrator output swing. Noise and

roll-over errors will be slightly worse than in the  $\pm 4V$  case. For large common-mode voltage ranges, the integrator output swing must be reduced further. This will increase both noise and roll-over errors. To improve performance,  $\pm 6V$  supplies may be used.

### Integrating Capacitor

The integrating capacitor,  $C_{INT}$ , should be selected to give the maximum integrator output voltage swing that will not saturate the integrator to within 0.3V from either supply. A  $\pm 3.5V$  to  $\pm 4V$  integrator output swing is nominal for the TC7109A, with  $\pm 5V$  supplies and analog common connected to GND. For 7-1/2 conversions per second (61.72 kHz internal clock frequency), nominal values  $C_{INT}$  and  $C_{AZ}$  are  $0.15 \mu F$  and  $0.33 \mu F$ , respectively. These values should be changed if different clock frequencies are used to maintain the integrator output voltage swing. The value of  $C_{INT}$  is given by:

$$C_{INT} = \frac{(2048 \times \text{Clock Period}) (20 \mu A)}{\text{Integrator Output Voltage Swing}}$$

The integrating capacitor must have low dielectric absorption to prevent roll-over errors. Polypropylene capacitors give undetectable errors, at reasonable cost, up to  $+85^\circ C$ . Teflon<sup>®</sup> capacitors are recommended for the military temperature range. While their dielectric absorption characteristics vary somewhat between units, devices may be selected to less than 0.5 count of error due to dielectric absorption.

### Integrating Resistor

The integrator and buffer amplifiers have a class A output stage with  $100 \mu A$  of quiescent current. They supply  $20 \mu A$  of drive current with negligible nonlinearity. The integrating resistor should be large enough to remain in this very linear region over the input voltage range, but small enough that undue leakage requirements are not placed on the PC board. For 2.048V full-scale a  $100 k\Omega$  resistor is recommended and for 409.6 mV full-scale a  $20 k\Omega$  resistor is recommended.  $R_{INT}$  may be selected for other values of full scale by:

$$R_{INT} = \frac{\text{Full-Scale Voltage}}{20 \mu A}$$

### Auto-Zero Capacitor

As the auto-zero capacitor is made large, the system noise is reduced. Since the TC7109A incorporates a zero integrator cycle, the size of the auto-zero capacitor does not affect overload recovery. The optimal value of the auto-zero capacitor is between 2 and 4 times  $C_{INT}$ . A typical value for  $C_{AZ}$  is  $0.33 \mu F$ .

T-51-10-12

## 12-BIT $\mu$ P-COMPATIBLE ANALOG-TO-DIGITAL CONVERTERS

TC7109  
TC7109A

2

The inner foil of  $C_{AZ}$  should be connected to pin 31 and the outer foil to the RC summing junction. The inner foil of  $C_{INT}$  should be connected to the RC summing junction and the outer foil to pin 32 for best rejection of stray pickups. For low leakage at temperatures above +85°C, use Teflon capacitors.

### Reference Capacitor

A 1  $\mu$ F capacitor is recommended for most circuits. However, where a large common-mode voltage exists, a larger value is required to prevent roll-over error (e.g., the reference low is not analog common), and a 409.6 mV scale is used. The roll-over error will be held to 0.5 count with a 10  $\mu$ F capacitor. For temperatures above +80°C use Teflon or equivalent capacitors for their low leakage characteristics.

### Reference Voltage

To generate full-scale output of 4096 counts, the analog input required is  $V_{IN} = 2 V_{REF}$ . For 409.6 mV full scale, use a reference of 204.8 mV. In many applications, where the ADC is connected to a transducer, a scale factor will exist between the input voltage and the digital reading. For instance, in a measuring system, the designer might like to have a full-scale reading when the voltage for the transducer is 700 mV. Instead of dividing the input down to 409.6 mV, the designer should use the input voltage directly and select  $V_{REF} = 350$  mV. Suitable values for integrating resistor and capacitor would be 34 k $\Omega$  and 0.15  $\mu$ F. This makes the system slightly quieter and also avoids a divider network on the input. Another advantage of this system occurs when temperature and weight measurements with an offset or tare are desired for non-zero input. The offset may be introduced by connecting the voltage output of the transducer between common and analog high, and the offset voltage between common and analog low, observing polarities carefully. In processor-based systems using the TC7109A, it may be more desirable to use software and perform this type of scaling or tare subtraction digitally.

### Reference Sources

A major factor in the absolute accuracy of the ADC is the stability of the reference voltage. The 12-bit resolution of the TC7109A is one part in 4096, or 244 ppm. Thus, for the on-board reference temperature coefficient of 70 ppm/°C, a temperature difference of 3°C will introduce a one-bit absolute error. Where the ambient temperature is not controlled, or where high-accuracy absolute measurements are being made, it is recommended an external high-quality reference be used.

A reference output (pin 29) is provided which may be used with a resistive divider to generate a suitable reference voltage (20 mA may be sunk without significant variation in output voltage). A pull-up bias device is provided which sources about 10  $\mu$ A. The output voltage is nominally 2.8V below  $V^+$ . When using the on-board reference, REF OUT (pin 29) should be connected to REF<sup>-</sup> (pin 39), and REF<sup>+</sup> should be connected to the wiper of a precision potentiometer between REF OUT and  $V^+$ . The test circuit shows the circuit for a 204.8 mV reference, generated by a 2 k $\Omega$  precision potentiometer in series with a 24 k $\Omega$  fixed resistor.

## Interfacing

### Direct Mode

Combinations of chip-enable and byte-enable control signals which may be used when interfacing the TC7109A to parallel data lines are shown in Figure 12. The  $\overline{CE/LOAD}$  input may be tied low, allowing either byte to be controlled by its own enable (Figure 12A). Figure 12B shows the  $\overline{HBEN}$  and  $\overline{LBEN}$  as flag inputs, and  $\overline{CE/LOAD}$  as a master enable, which could be the READ strobe available from most microprocessors. Figure 12C shows a configuration where the two byte enables are connected together. The  $\overline{CE/LOAD}$  is a chip enable, and the  $\overline{HBEN}$  and  $\overline{LBEN}$  may be used as a second chip enable, or connected to ground. The 14 data outputs will be enabled at the same time. In the direct MODE, SEND should be tied to  $V^+$ .

Figure 13 shows interfacing several TC7109A's to a bus, ganging the  $\overline{HBEN}$  and  $\overline{LBEN}$  signals to several converters together, and using the  $\overline{CE/LOAD}$  input to select the desired converter.

Figures 14–19 give practical circuits utilizing the parallel three-state output capabilities of the TC7109A. Figure 14 shows parallel interface to the Intel MCS-48, -80 and -85 systems via an 8255 PPI, where the TC7109A data outputs are active at all times. The 8155 I/O ports may be used in an identical manner. This interface can be used in a read-after-update sequence, as shown in Figure 15. The data is accessed by the high-to-low transition of the STATUS driving an interrupt to the microprocessor.

The RUN/HOLD input is also used to initiate conversions under software control. Figure 16 gives an interface to Motorola MC6800 or MOS Technology MCS650X system.

An interrupt is generated through the Control Register B, CB1 line from the high-to-low transition of the STATUS output. The RUN/HOLD pin is controlled by CB2 through Control Register B, allowing software control of conversions.

T-51-10-12

12-BIT  $\mu$ P-COMPATIBLE  
ANALOG-TO-DIGITAL CONVERTERS

TC7109  
TC7109A

Direct interfacing to most microprocessor busses is easily accomplished through the three-state output of the TC7109A.

Figures 1, 17 and 18 are typical connection diagrams. To ensure requirements for setup and hold times, minimum pulse widths, and the drive limitations on long busses are

met, it is necessary to carefully consider the system timing in this type of interface. This type of interface is used when the memory peripheral address density is low, providing simple address decoding. Interrupt handling can be simplified by using an interface to reduce the component count.

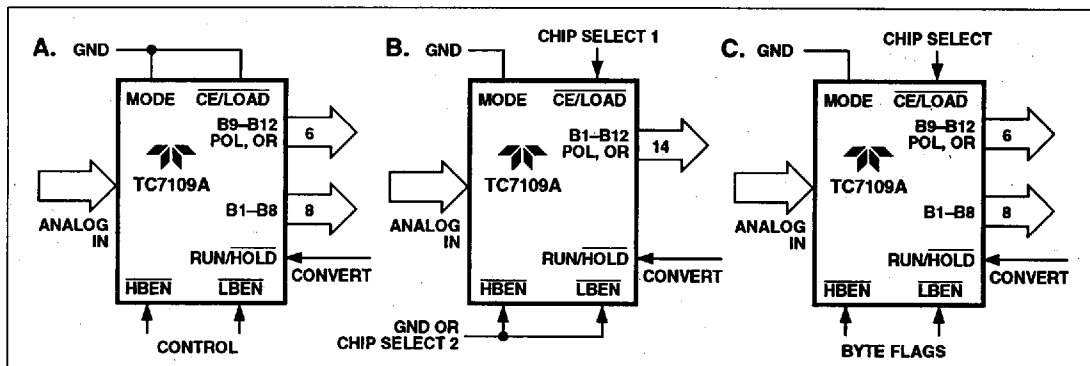

Figure 12 Direct Mode Chip and Byte Enable Combinations

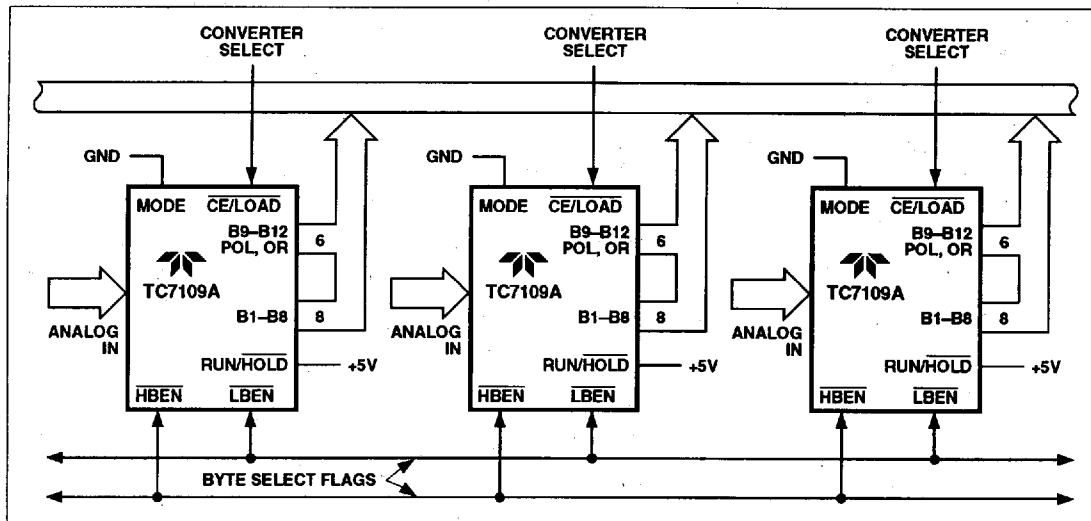

Figure 13 Three-Stating Several TC7109A's to a Small Bus

12-BIT  $\mu$ P-COMPATIBLE  
ANALOG-TO-DIGITAL CONVERTERS

T-51-10-12

TC7109  
TC7109A

2

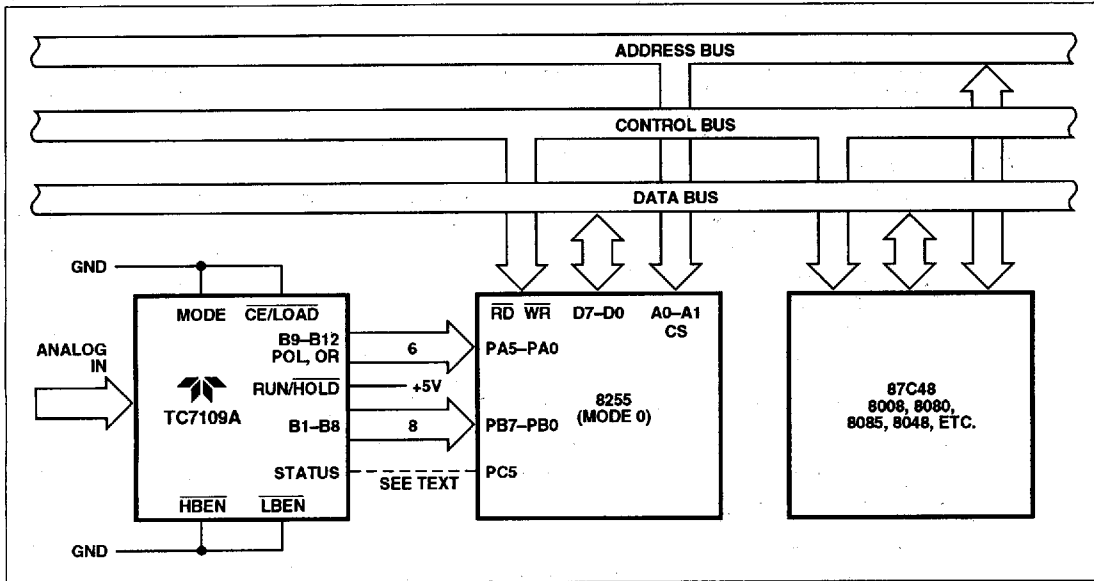

Figure 14 Full-Time Parallel Interface to MCS-48, -80, -85 Microcomputers

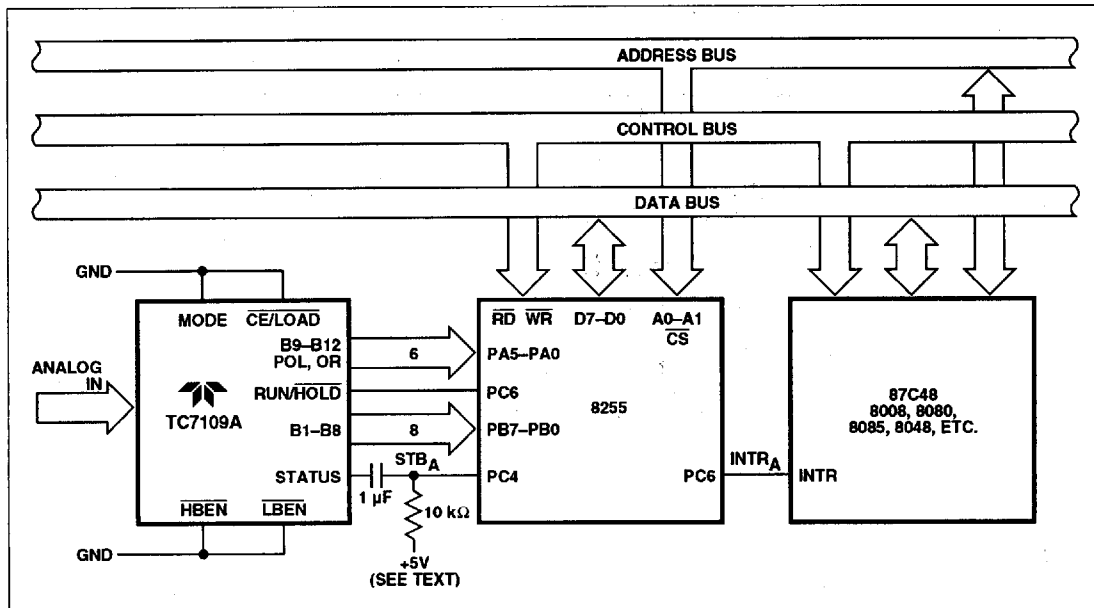

Figure 15 Full-Time Parallel Interface to MCS-48, -80, -85 Microcomputers With Interrupt

T-51-10-12

12-BIT  $\mu$ P-COMPATIBLE  
ANALOG-TO-DIGITAL CONVERTERS

TC7109  
TC7109A

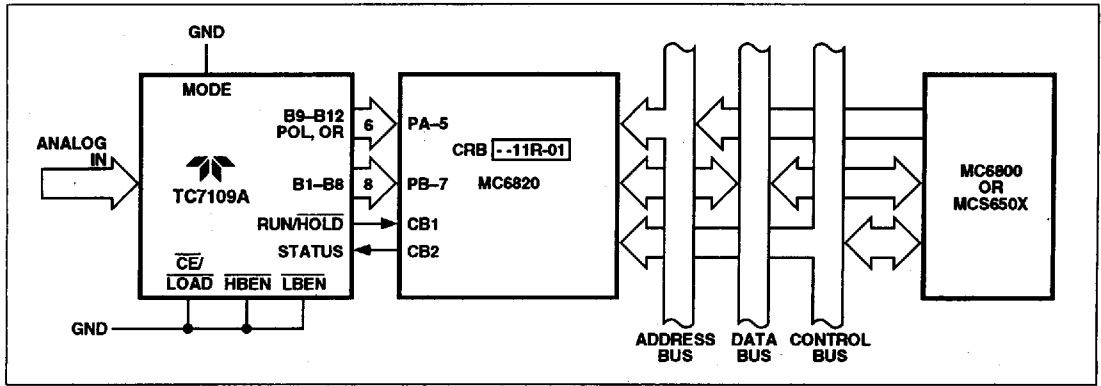

Figure 16 Full-Time Parallel Interface to MC6800 or MCS650X Microprocessor

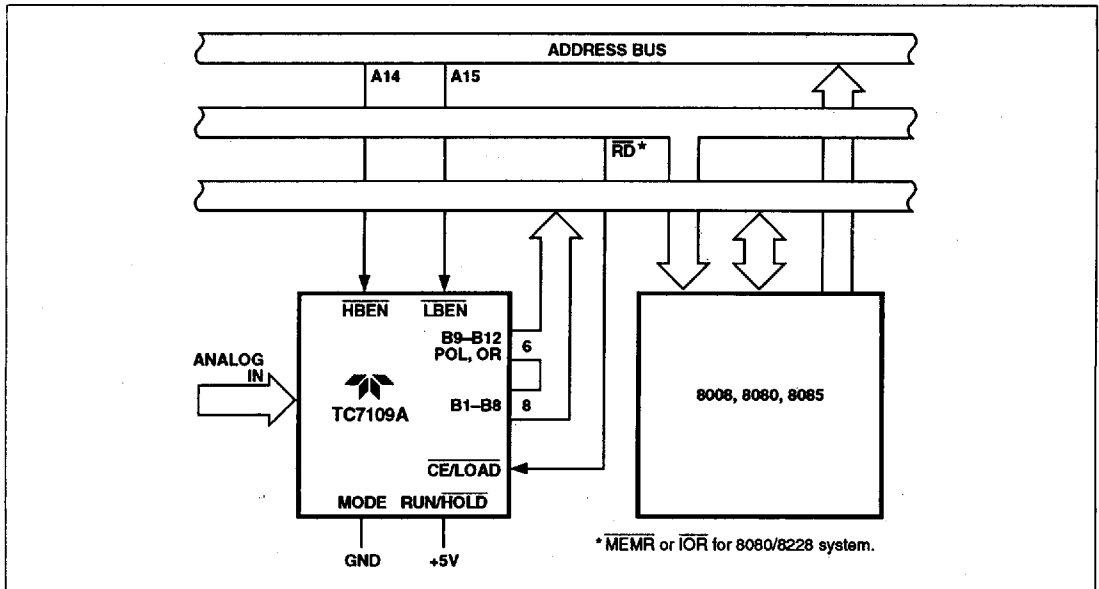

Figure 17 TC7109A Direct Interface to 8080/8085

T-51-10-12

12-BIT  $\mu$ P-COMPATIBLE  
ANALOG-TO-DIGITAL CONVERTERS

TC7109  
TC7109A

2

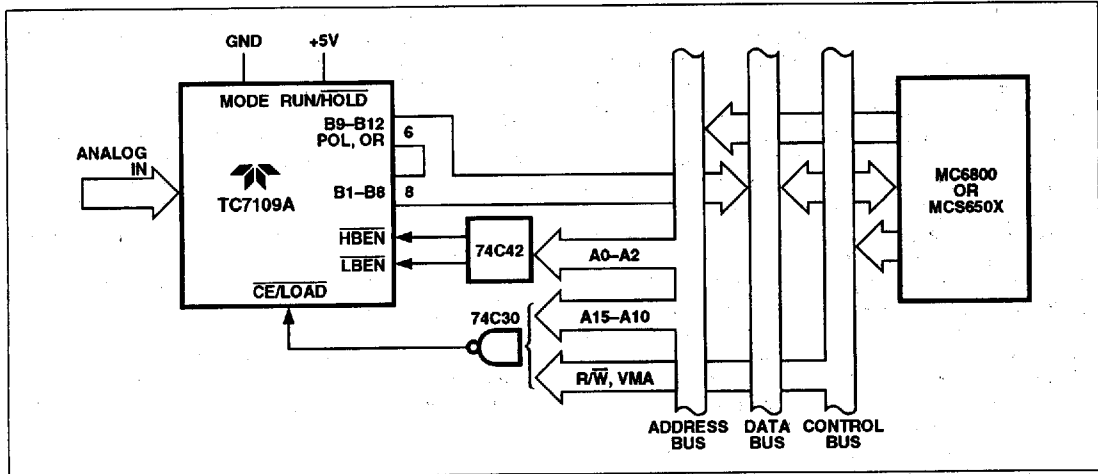

Figure 18 TC7109A Direct Interface to MC6800 Bus

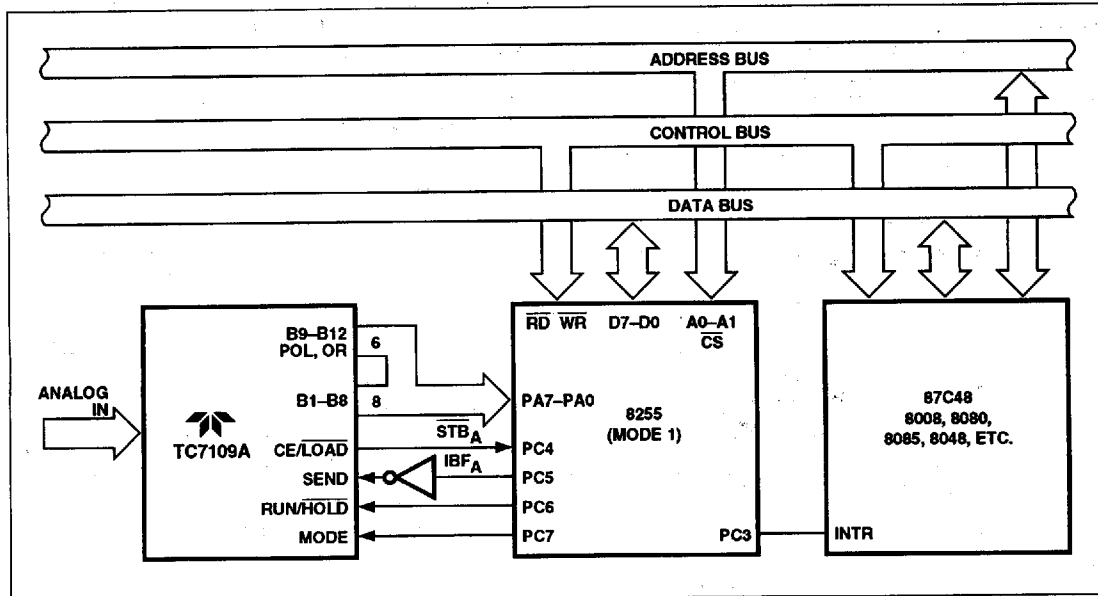

Figure 19 TC7109A Handshake Interface to MCS-48, -80, -85 Microcomputers

## 12-BIT $\mu$ P-COMPATIBLE ANALOG-TO-DIGITAL CONVERTERS

TC7109  
TC7109A

T-51-10-12

### Handshake Mode

The handshake mode provides an interface to a wide variety of external devices. The byte enables may be used as byte identification flags or as load enables and external latches may be clocked by the rising edge of  $\overline{\text{CE/LOAD}}$ . A handshake interface to Intel microprocessors using an 8255 PPI is shown in Figure 19. The handshake operation with the 8255 is controlled by inverting its Input Buffer Full (IBF) flag to drive the SEND input to the TC7109A, and using the  $\overline{\text{CE/LOAD}}$  to drive the 8255 strobe. The internal control register of the PPI should be set in MODE 1 for the port used. If the 8255 IBF flag is low and the TC7109A is in handshake mode, the next word will be strobed into the port. The strobe will cause IBF to go high (SEND goes low), which will keep the enabled byte outputs active. The PPI will generate an interrupt which, when executed, will result in the data being read. The IBF will be reset low when the byte is read, causing the TC7109A to sequence into the next byte. The MODE input to the TC7109A is connected to the control line on the PPI.

The data from every conversion will be sequenced in two bytes in the system, if this output is left high, or tied high separately. (The data access must take less time than a conversion.) The output sequence can be obtained on demand if this output is made to go from low to high, and the interrupt may be used to reset the MODE bit.

Conversions may be obtained on command under software control by driving the RUN/HOLD input to the TC7109A

by a bit of the 8255. Another peripheral device may be serviced by the unused port of the 8255. The 8155 may be used in a similar manner. The MCS650X microprocessors are shown in Figure 20 with MODE and RUN/HOLD tied high to save port outputs.

The handshake mode is particularly useful for directly interfacing to industry-standard UARTs (such as Western Digital TR1602), providing a means of serially transmitting converted data with minimum component count.

A typical UART connection is shown in Figure 1. In this circuit, any word received by the UART causes the UART DR (Data Ready) output to go high. The MODE input to the TC7109A goes high, triggering the TC7109A into handshake mode. The high-order byte is output to the UART and when the UART has transferred the data to the Transmitter register, TBRE (SEND) goes high again,  $\overline{\text{LBEN}}$  will go high, driving the UART DRR (Data Ready Reset) which will signal the end of the transfer of data from the TC7109A to the UART.

An extension of the typical connection to several TC7109A's with one UART is shown in Figure 21. In this circuit, the word received by the UART (available at the RBR outputs when DR is high) is used to select which converter will handshake with the UART. Up to eight TC7109A's may interface with one UART, with no external components. Up to 256 converters may be accessed on one serial line with additional components.

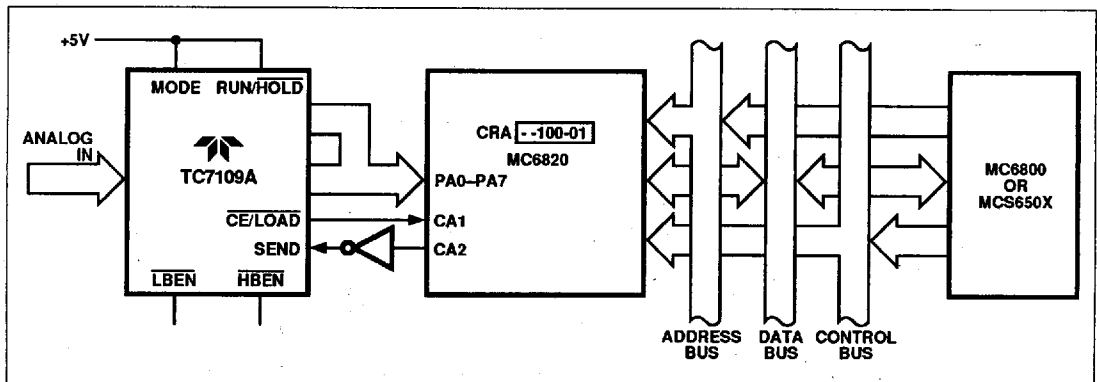

Figure 20 TC7109A Handshake Interface to MCS-6800, MCS650X Microprocessors

T-51-10-12

12-BIT  $\mu$ P-COMPATIBLE  
ANALOG-TO-DIGITAL CONVERTERS

TC7109  
TC7109A

2

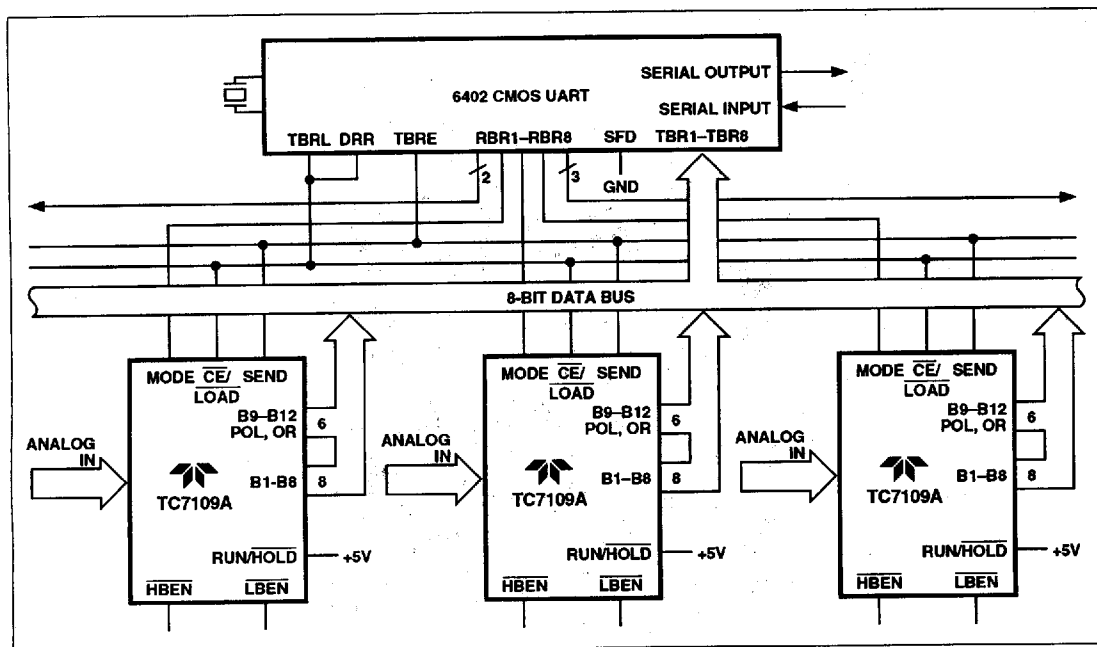

Figure 21 Handshake Interface for Multiplexed Converters

Integrating Converter Features

The output of integrating ADCs represents the integral, or average, of an input voltage over a fixed period of time. Compared with techniques in which the input is sampled and held, the integrating converter averages the effects of noise. A second important characteristic is that time is used to quantize the answer, resulting in extremely small, nonlinearity errors and no missing output codes. The integrating converter also has very good rejection of frequencies whose periods are an integral multiple of the measurement period. This feature can be used to advantage in reducing line frequency noise (Figure 22).

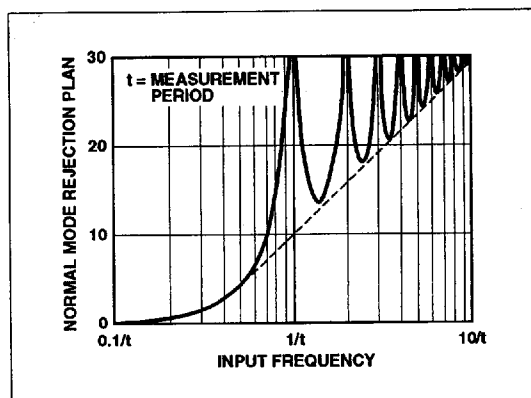

Figure 22 Normal Mode Rejection of Dual-Slope Converter as a Function of Frequency

12-BIT  $\mu$ P-COMPATIBLE  
ANALOG-TO-DIGITAL CONVERTERS

TC7109  
TC7109A

T-51-10-12

BONDING DIAGRAM

