



DM74ALS1002A

Quadruple 2-Input Positive-NOR Buffer

General Description

This device contains four independent 2-input buffers, each of which performs the logic NOR function. The 'ALS1002A is a buffer version of the 'ALS02.

Features

- Switching specifications at 50 pF
- Switching specifications guaranteed over full temperature and V_{CC} range
- Advanced oxide-isolated, ion-implanted Schottky TTL process
- Improved line receiving characteristics

Connection Diagram

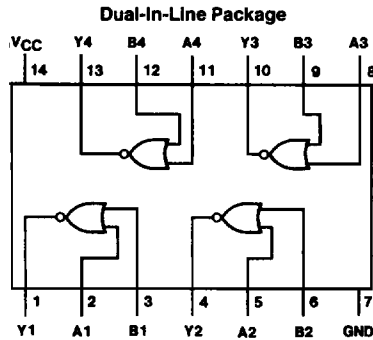

Order Number DM74ALS1002AM or DM74ALS1002AN
See NS Package Number M14A or N14A

Function Table

$$Y = \overline{A + B}$$

Inputs		Output
A	B	Y
L	L	H
L	H	L
H	L	L
H	H	L

H = High Logic Level

L = Low Logic Level

Absolute Maximum Ratings

Supply Voltage	7V
Input Voltage	7V
Operating Free Air Temperature Range DM74ALS	0°C to +70°C
Storage Temperature Range	-65°C to +150°C
Typical θ_{JA}	
N Package	83.0°C/W
M Package	114.0°C/W

Note: The "Absolute Maximum Ratings" are those values beyond which the safety of the device cannot be guaranteed. The device should not be operated at these limits. The parametric values defined in the "Electrical Characteristics" table are not guaranteed at the absolute maximum ratings. The "Recommended Operating Conditions" table will define the conditions for actual device operation.

Recommended Operating Conditions

Symbol	Parameter	DM74ALS1002A			Units
		Min	Nom	Max	
V _{CC}	Supply Voltage	4.5	5	5.5	V
V _{IH}	High Level Input Voltage	2			V
V _{IL}	Low Level Input Voltage			0.8	V
I _{OH}	High Level Output Current			-2.6	mA
I _{OL}	Low Level Output Current			24	mA
T _A	Free Air Operating Temperature	0		70	°C

Electrical Characteristics

over recommended operating free air temperature range. All typical values are measured at V_{CC} = 5V, T_A = 25°C.

Symbol	Parameter	Conditions	Min	Typ	Max	Units
V _{IK}	Input Clamp Voltage	V _{CC} = 4.5V, I _I = -18 mA			-1.5	V
V _{OH}	High Level Output Voltage	V _{CC} = 4.5V V _{IL} = V _{IL} Max	I _{OH} = Max	2.4	3.2	V
		V _{CC} = 4.5V to 5.5V	I _{OH} = -400 μ A	V _{CC} - 2		V
V _{OL}	Low Level Output Voltage	V _{CC} = 4.5V V _{IH} = 2V	I _{OL} = 12 mA		0.25	V
			I _{OL} = 24 mA		0.35	V
I _I	Input Current @ Max Input Voltage	V _{CC} = 5.5V, V _{IH} = 7V			0.1	mA
I _{IH}	High Level Input Current	V _{CC} = 5.5V, V _{IH} = 2.7V			20	μ A
I _{IL}	Low Level Input Current	V _{CC} = 5.5V, V _{IL} = 0.4V			-0.1	mA
I _O	Output Drive Current	V _{CC} = 5.5V, V _O = 2.25V	-30		-112	mA
I _{CC} H	Supply Current with Outputs High	V _{CC} = 5.5V, V _I = 0V		1.7	2.8	mA
I _{CC} L	Supply Current with Outputs Low	V _{CC} = 5.5V, V _I = 4.5V		5.6	9	mA

Switching Characteristics

over recommended operating free air temperature range (Note 1)

Symbol	Parameter	Conditions	DM74ALS1002A		Units
			Min	Max	
t _{PLH}	Propagation Delay Time Low to High Level Output	V _{CC} = 4.5V to 5.5V R _L = 500 Ω C _L = 50 pF	2	8	ns
t _{PHL}	Propagation Delay Time High to Low Level Output		3	7	ns

Note 1: See Section 1 for test waveforms and output load.