

MPX2000 / MPZ2000 series

2 μm band low frequencies to 12 GHz Phase Modulators

MODULATOR



The MPX2000 and MPZ2000 are phase modulators specially designed for phase modulation in the 2.0 μm wavelength band from low frequencies to 10 GHz and above. The MPX/MPZ2000 incorporate 2.0 μm specific waveguides and are pigtailed with 2.0 μm polarization maintaining fibers.

FEATURES

- Low insertion loss
- Low V_{π}
- 2 μm specific design

APPLICATIONS

- LIDAR
- Gas sensing
- Spectral broadening
- Spectroscopy
- Seed source
- Research & development

OPTIONS

- Lower Insertion Loss
- Low Residual Amplitude Modulation

RELATED EQUIPMENTS

- MX2000 Amplitude modulator
- 2 MHz to 500 MHz amplifiers
- Matched RF amplifiers
- Spectral Broadening ModBox

MPX2000-LN-0.1 Performance Highlights

Parameter	Min	Typ	Max	Unit
Operating wavelength	1900	2000	2200	nm
Electro-optical bandwidth	100	150	-	MHz
V_{π} RF @50 kHz	-	5	-	V
Insertion loss	-	3	-	dB

Specifications given at 25 °C, 2050 nm

MPZ2000-LN-10 Performance Highlights

Parameter	Min	Typ	Max	Unit
Operating wavelength	1900	2050	2200	nm
Electro-optical bandwidth	10	12	-	GHz
V_{π} RF @50 kHz	-	6.5	-	V
Insertion loss	-	3	4	dB

Specifications given at 25 °C, 2050 nm

MPX2000 / MPZ2000 series

2 μm band low frequencies to 12 GHz Phase Modulators

MODULATOR

MPX2000-LN-0.1

150 MHz Phase Modulator

Electrical Characteristics

Parameter	Symbol	Condition	Min	Typ	Max	Unit
Electro-optic bandwidth	S_{21}	RF electrodes	100	150	-	MHz
V_{π} RF @ 50 kHz	V_{π} RF _{50 kHz}	RF electrodes	-	3.5	-	V
RF input impedance	Z_{in-RF}	-	-	10	-	k Ω

Optical Characteristics

Parameter	Symbol	Condition	Min	Typ	Max	Unit
Crystal	-	-	Lithium Niobate X-Cut Y-Prop			
Waveguide process	-	-	Ti diffusion			
Operating wavelength	λ	-	1900	2000	2200	nm
Insertion loss	IL	Without connectors	-	3	5	dB
Optical return loss	ORL	-	-40	-45	-	dB

All specifications given at 25 $^{\circ}\text{C}$, 2050 nm, unless differently specified

Absolute Maximum Ratings

Stresses in excess of the absolute maximum ratings can cause permanent damage to the device. These are absolute stress ratings only. Functional operation of the device is not implied at these or any other conditions in excess of those given in the operational sections of the data sheet. Exposure to absolute maximum ratings for extended periods can adversely affect device reliability.

Parameter	Symbol	Min	Max	Unit
Modulation voltage range	EV_{in}	-20	20	V
Optical input power	OP_{in}	-	20	dBm
Operating temperature	OT	0	+70	$^{\circ}\text{C}$
Storage temperature	ST	-40	+85	$^{\circ}\text{C}$

MPX2000 / MPZ2000 series

2 μ m band low frequencies to 12 GHz Phase Modulators

MODULATOR

MPZ2000-LN-10

10 GHz Phase Modulator

Electrical Characteristics

Parameter	Symbol	Condition	Min	Typ	Max	Unit
Electro-optic bandwidth	S_{21}	-	10	12	-	GHz
Ripple S_{21}	ΔS_{21}	-	-	0.5	1	dB
Electrical return loss	S_{11}	-	-	-12	-10	dB
V_{π} RF @ 50 kHz	$V_{\pi RF_{50\text{ kHz}}}$	-	-	6.5	7.5	V
Impedance matching	Z_{in-RF}	-	-	50	-	Ω

50 Ω RF input

Optical Characteristics

Parameter	Symbol	Condition	Min	Typ	Max	Unit
Crystal	-	-	Lithium Niobate X-Cut Y-Prop			
Waveguide process	-	-	Ti diffusion			
Operating wavelength	λ	-	1900	2000	2200	nm
Insertion loss	IL	Without connectors	-	3	4	dB
Optical return loss	ORL	-	-40	-45	-	dB

All specifications given at 25 °C, 2050 nm, unless differently specified

Absolute Maximum Ratings

Stresses in excess of the absolute maximum ratings can cause permanent damage to the device. These are absolute stress ratings only. Functional operation of the device is not implied at these or any other conditions in excess of those given in the operational sections of the data sheet. Exposure to absolute maximum ratings for extended periods can adversely affect device reliability.

Parameter	Symbol	Min	Max	Unit
RF input power	EP_{in}	-	28	dBm
Optical input power	OP_{in}	-	20	dBm
Operating temperature	OT	0	+70	°C
Storage temperature	ST	-40	+85	°C

MPX2000 / MPZ2000 series
2 μm band low frequencies to 12 GHz Phase Modulators

MODULATOR

Mechanical Diagram and Pinout

All measurements in mm

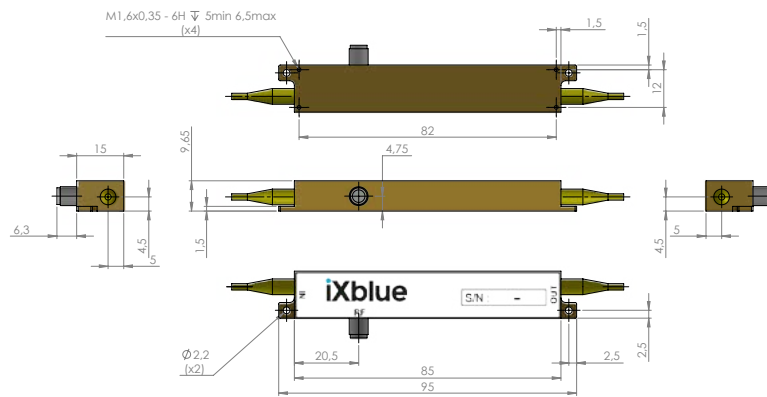

Port	Function	Note
IN	Optical input port	2000 nm Polarization maintaining fiber, Nufern PM1950, length : 1.5 meter
OUT	Optical output port	2000 nm Polarization maintaining fiber, Nufern PM1950, length : 1.5 meter
RF	RF input port	Female K (SMA compatible)

Ordering information

MPX2000-LN-0.1-00-Y-Z-AB-CD / MPZ2000-LN-10-00-Y-Z-AB-CD

Y = Input fiber: P Polarization maintaining S Standard single mode
 Z = Output fiber: P Polarization maintaining S Standard single mode
 AB = Input connector: 00 bare fiber FA FC/APC FC FC/SPC
 CD = Output connector: 00 bare fiber FA FC/APC FC FC/SPC
 Note : optical connectors are Senko with narrow key or equivalent

About us

iXblue Photonics includes iXblue iXBlue brand that produces specialty optical fibers and Bragg gratings based fiber optics components and iXblue Photonics brand that provides optical modulation solutions based on the company lithium niobate (LiNbO₃) modulators and RF electronic modules.

iXblue Photonics serves a wide range of industries: sensing and instruments, defense, telecommunications, space and fiber lasers as well as research laboratories all over the world.

iXblue reserves the right to change, at any time and without notice, the specifications, design, function or form of its products described herein. All statements, specification, technical information related to the products herein are given in good faith and based upon information believed to be reliable and accurate at the moment of printing. However the accuracy and completeness thereof is not guaranteed. No liability is assumed for any inaccuracies and as a result of use of the products. The user must validate all parameters for each application before use and he assumes all risks in connection with the use of the products