

AK27CX161/162

16Kbit CMOS High-Speed UV-Erasable PROM

FEATURES

- 2048 word × 8 bit
- Advanced CMOS EPROM Technology
- High Performance
 - AK27CX161/162-35 ... $t_{AA} = 35$ ns max.
 - AK27CX161/162-40 ... $t_{AA} = 40$ ns max.
 - AK27CX161/162-45 ... $t_{AA} = 45$ ns max.
- Low Power Consumption
 - $I_{CC} = 40$ mA max. — Active
 - $I_{SB} = 500$ μ A typ. — Standby Mode

- TTL-Compatible I/O
- Reprogrammability
 - Adds convenience, reduces costs
 - Windowed package for UV erasure
 - Allows 100% factory testing
- Bipolar PROM replacement
 - Pin-compatible with Bipolar PROMs
 - Higher speed
 - Lower power consumption
 - 300-mil (AK27CX162) and 600-mil (AK27CX161) packages

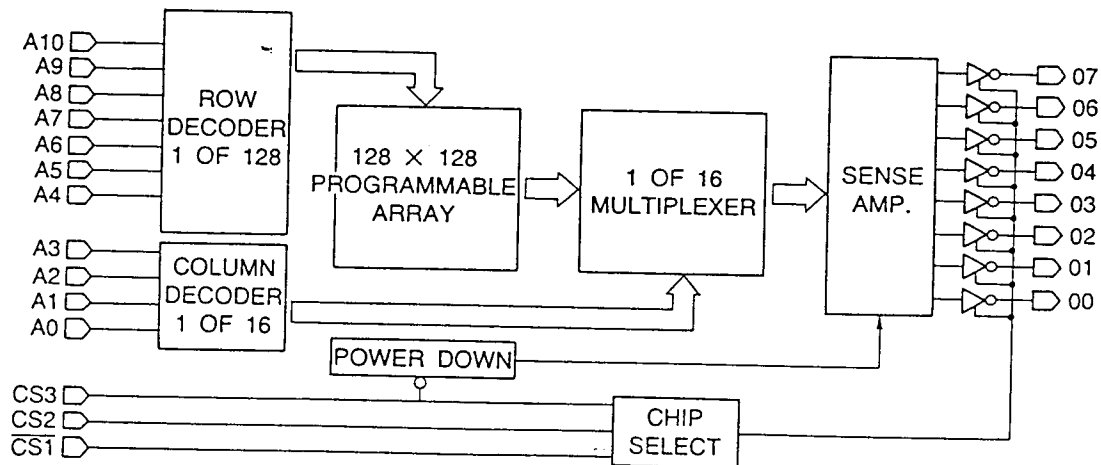

Block Diagrams

GENERAL DESCRIPTION

The AKM AK27CX161 and AK27CX162 are 2048 × 8 bit, CMOS, high-speed, UV-erasable PROMs that provide a low-power, reprogrammable alternative to bipolar fuse-link PROMs. Available in both 600 mil (AK27CX161) and 300 mil (AK27CX162) packages, these devices are pin/socket-compatible with many popular bipolar PROMs. The AK27CX161/162 is designed in an advanced CMOS EPROM technology and utilize differential memory cell techniques to provide access times comparable to high-speed bipolar PROMs

(as fast as 35ns), with a significant improvement in power consumption. A special, user-programmable, low-power standby mode reduces power consumption even further when the device is deselected. The reprogrammability of the AK27CX161/162 not only adds convenience and reduces development and field retrofit costs, but enhances factory testability, allowing for 100% field programmability and function.

Pin Configuration

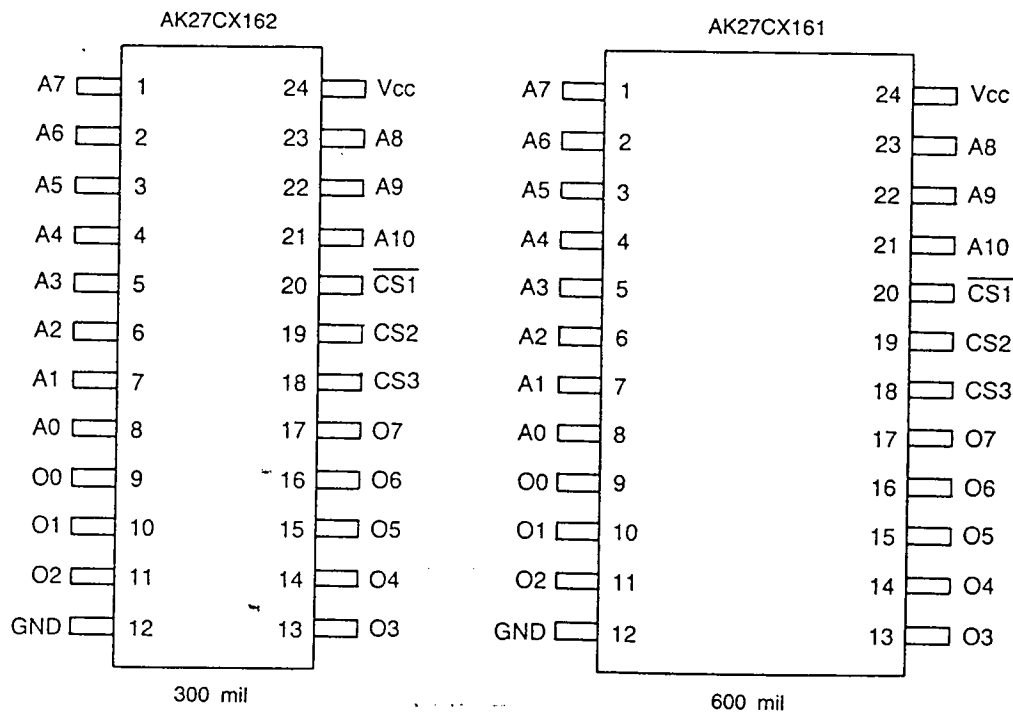

A0-A10= Address Input
 O0-O7= Data Output
 CS1 = Chip Select 1
 CS2 = Chip Select 2
 CS3 = Chip Select 3
 GND = Ground
 Vcc = Power Supply (+5V)

Standby Low-Power Mode

The low-power standby mode is a user-selectable option that can be set using programming equipment that supports the AK27CX161/162. If this mode is set, the AK27CX161/162 will power-down to typically 500µA supply current while CS3 is asserted low. The delay from CS3 low to power-down is approximately 45ns. Note that chip-select-to-data-out timing for CS3 will change if the standby mode is selected (refer to the specification for t_{CS3} under A.C. Electrical Characteristics). For information on selecting the standby option, please contact your programmer manufacturer or AKM.

Erasure Characteristics

The AK27CX161/162 is erased by exposure to ultraviolet light. For complete erasure, the recommended minimum integrated dose (UV intensity x exposure time) is 15 Watt-second/cm² of ultraviolet light with a wavelength of 2537Å. For an ultraviolet lamp with a 12mW/cm² power rating, the exposure time would be approximately 20 minutes. The AK27CX161/162 should be placed within one inch of the lamp during erasure. Exposing the CMOS EPROM to high-intensity UV-light for extended periods may affect device reliability.

Programming the AK27CX161/162

The AK27CX161/162 employs a dual-transistor differential memory cell design. Initially, and after erasure, all bits of the AK27CX161/162 are in an underfined state. Thus, verifying a blank device will yield erroneous results. The desired state of each bit must be programmed into the device to ensure proper operation. Programming support is available from third-party vendors. For more information on programming support and programming specifications, please contact AKM.

ABSOLUTE MAXIMUM RATINGS

Exposure to absolute maximum ratings over extended periods of time may affect device reliability. Exceeding absolute maximum ratings may cause permanent damage.

Symbol	Parameter	Conditions	Rating	UNIT
V_{CC}	Supply Voltage	Relative to GND	-0.6 ~ +7.0	V
V_{IO}	Voltage Applied to Any Pin	Relative to GND	-0.6 ~ $V_{CC}+0.6$	V
T_A	Ambient Temp., Power Applied		-10 ~ +85	°C
T_{ST}	Storage Temperature		-65 ~ +125	°C
T_{LT}	Lead Temperature	Soldering 10 seconds	+260	°C

OPERATING RANGES

Symbol	Parameter	Conditions	MIN.	MAX.	UNIT
V_{CC}	Supply Voltage		4.75	5.25	V
T_A	Ambient Temperature		0	70	°C

D.C. ELECTRICAL CHARACTERISTICS

Over the operating range

Symbol	Parameter	Conditions	MIN.	MAX.	UNIT
V_{IH}	Input HIGH Level		2.0		V
V_{IL}	Input LOW Level			0.8	V
V_{OH}	Output HIGH Voltage ¹	$V_{CC}=\text{min.}, I_{OH}=-4.0\text{mA}$	2.4		V
V_{OL}	Output LOW Voltage	$V_{CC}=\text{min.}, I_{OL}=12\text{mA}$		0.45	V
I_L	Input Leakage Current	$V_{CC}=\text{max.}, \text{GND} \leq V_1 \leq V_{CC}$		10	μA
I_{OS}	Output Short Circuit Current ²	$V_{CC}=\text{max.}, V_O=\text{GND}$ $CS1=V_{IL}$ and $CS2=V_{IH}$	-15	-90	mA
I_{OZ}	Output Leakage Current	$V_O=V_{CC}$ or GND $CS1=V_{IH}, CS2=V_{IL}$ or $CS3=V_{IL}, V_{CC}=\text{max.}$		10	μA
I_{CC}	Power Supply Current	All inputs = (GND or V_{CC}) ± 0.3V		40	mA
I_{SB}	Standby Current ³	$CS3=V_{IL}$, Other Inputs = (GND or V_{CC}) ± 0.3V	0.1	5	mA
V_{IC}	Input Clamp Voltage	$V_{CC}=\text{min.}, I_{IN}=-10\text{mA}$		-1.2	V

Capacitance These measurements are periodically sample tested

Symbol	Parameter	Conditions	MIN.	MAX.	UNIT
C_{IN}	Input Capacitance	$T_A=25^\circ\text{C}$ $V_{CC}=5.0\text{V}$ @ $f=1\text{MHz}$		6	pF
C_{OUT}	Output Capacitance			12	pF
C_{CS1}	CS1 Pin Capacitance			15	pF
C_{CS2}, C_{CS3}	CS2, CS3 Pin Capacitance			6	pF

Notes:

1. The AK27CX161/162 provide true CMOS output interface levels. The specifications shown are for TTL interface.
2. No more than one output should be shorted at a time. Duration of short circuit should not be more than one second.
3. Applicable only if standby mode is programmed.

A.C. ELECTRICAL CHARACTERISTICS

Over the Operating Range⁴

Symbol	Parameter	27CX161-35 27CX162-35		27CX161-40 27CX162-40		27CX161-45 27CX162-45		UNIT
		MIN.	MAX.	MIN.	MAX.	MIN.	MAX.	
t_{AA}	Access Time From Address To Output		35		40		45	ns
t_{CS}	Access Time From Chip Select 1,2 or 3 to Output ⁵		20		25		25	ns
t_{CS3}	Chip Select 3 to Output in Standby Mode ^{3,5}		30		30		35	ns
t_{CD}	Chip Select 1,2 or 3 Disable to High-Z ^{5,6}		25		25		25	ns

Switching Waveforms

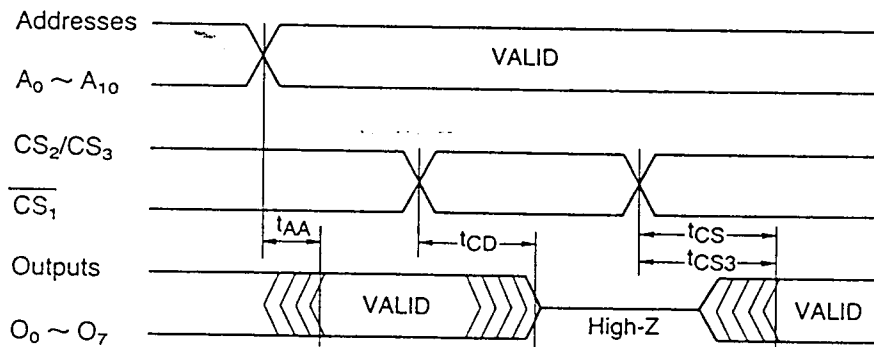

Test Loads

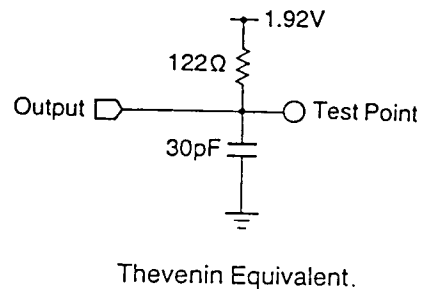
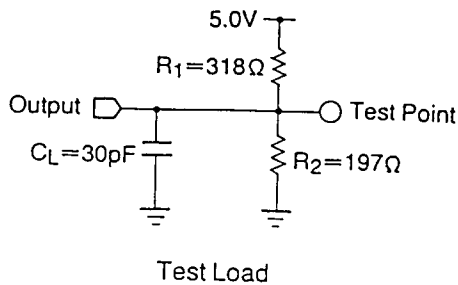

Note:

- Test conditions assume: signal transition times of 5ns or less from the 10% and 90% points; timing reference levels of 1.5V (unless otherwise specified); and test loads shown.
- t_{CS} , t_{CS3} , and t_{CD} are measured at the midpoint between output (O_{0-7}) steady-state high-Z level and V_{OH} or V_{OL} .
- C_L includes scope and jig capacitance. t_{CD} is tested with $C_L = 5pF$.