

# Agilent ABA-31563 3.5 GHz Broadband Silicon RFIC Amplifier Data Sheet

## Description

Agilent's ABA-31563 is an economical, easy-to-use, internally 50Ω matched, silicon monolithic broadband amplifier that offers excellent gain and broadband response from DC to 3.5 GHz. Packaged in an ultra-miniature SOT-363 package, it requires half the board space of a SOT-143 package.

At 2 GHz, the ABA-31563 offers a small-signal gain of 21.5 dB, output P1dB of 2.2 dBm and 13.1 dBm output third order intercept point. It is suitable for use as wideband applications. They are designed for low cost gain blocks in cellular applications, DBS tuners, LNB and other wireless communication systems.

ABA-31563 is fabricated using Agilent's HP25 silicon bipolar process, which employs a double-diffused single polysilicon process with self-aligned submicron emitter geometry. The process is capable of simultaneous high  $f_T$  and high NPN breakdown (25 GHz  $f_T$  at 6V BVCEO). The process utilizes industry standard device oxide isolation technologies and submicron aluminum multilayer interconnect to achieve superior performance, high uniformity, and proven reliability.

## Surface Mount Package SOT-363/SC70

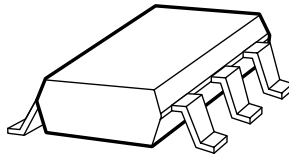

## Pin Connections and Package Marking

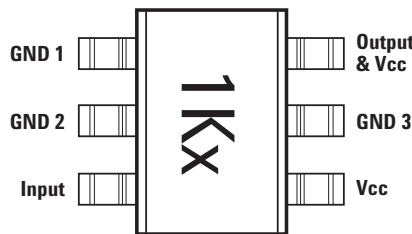

**Note:**  
Top View. Package marking provides orientation and identification. "x" is the date code.

## Simplified Schematic

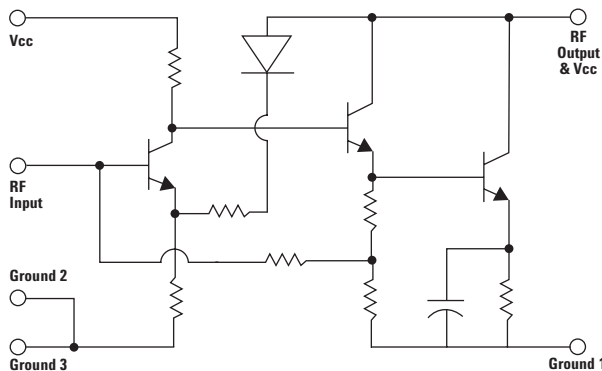

## Features

- Operating Frequency DC ~ 3.5GHz
- 21.5 dB Gain
- VSWR < 2.0 throughout operating frequency
- 2.2 dBm Output P1dB
- 13.1 dBm Output IP3
- 3.8 dB Noise Figure
- Unconditionally Stable
- Single 3V Supply ( $I_d = 14$  mA)

## Applications

- Amplifier for Cellular, Cordless, Special Mobile Radio, PCS, ISM, Wireless LAN, DBS, TVRO, and TV Tuner Applications



## ABA-31563 Absolute Maximum Ratings<sup>[1]</sup>

Symbol	Parameter	Units	Absolute Max.
$V_{cc}$	Device Voltage, RF output to ground (T = 25°C)	V	6
$P_{in}$	CW RF Input Power (V <sub>cc</sub> = 3V)	dBm	15
$P_{diss}$	Total Power Dissipation <sup>[3]</sup>	W	0.3
$T_j$	Junction Temperature	°C	150
$T_{STG}$	Storage Temperature	°C	-65 to 150

**Thermal Resistance<sup>[2]</sup> (V<sub>cc</sub> = 3V)**  
 $\theta_{j-c} = 125^{\circ}\text{C}/\text{W}$

**Notes:**

1. Operation of this device in excess of any of these limits may cause permanent damage.
2. Thermal resistance measured using 150°C Liquid Crystal Measurement Technique.
3. Board (package belly) temperature, T<sub>c</sub>, is 25°C. Derate 2.3 mW/°C for T<sub>c</sub> > 120.8°C.

## Electrical Specifications

T<sub>c</sub> = +25°C, Z<sub>0</sub> = 50 Ω, P<sub>in</sub> = -30 dBm, V<sub>cc</sub> = 3V, Freq = 2 GHz, unless stated otherwise.

Symbol	Parameter and Test Condition	Units	Min.	Typ.	Max.	Std Dev.
Gp <sup>[1]</sup>	Power Gain ( $ S_{21} ^2$ )	dB	20.0	21.5		
ΔGp	Power Gain Flatness, f = 0.1 ~ 2.5 GHz f = 0.1 ~ 3.5 GHz	dB		0.2 1.3		
NF <sup>[1]</sup>	Noise Figure	dB		3.8	4.8	
P1dB <sup>[1]</sup>	Output Power at 1dB Gain Compression	dBm		2.2		
OIP3 <sup>[1]</sup>	Output Third Order Intercept Point	dBm		13.1		
VSWR <sub>in</sub> <sup>[1]</sup>	Input VSWR			<1.5		
VSWR <sub>out</sub> <sup>[1]</sup>	Output VSWR			<1.5		
I <sub>cc</sub> <sup>[1]</sup>	Device Current	mA		14	16	
T <sub>d</sub> <sup>[1]</sup>	Group Delay	ps		140		

**Notes:**

1. Measurements taken on 50Ω test board shown on Figure 1. Excess circuit losses had been de-embedded from actual measurements. Standard deviation and typical data based on at least 500 parts sample size from 2 wafer lots. Future wafers allocated to this product may have nominal values anywhere within the upper and lower spec limits.

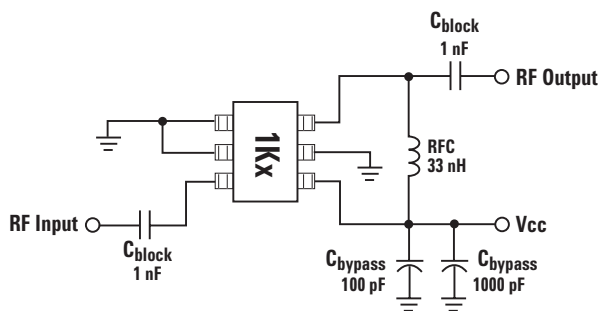

Figure 1. ABA-31563 Production Test Circuit.

### ABA-31563 Typical Performance

$T_c = +25^\circ\text{C}$ ,  $Z_o = 50\Omega$ ,  $V_{cc} = 3\text{V}$  unless stated otherwise.

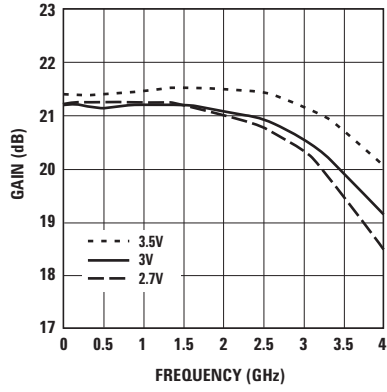

Figure 2. Gain vs. Frequency and Voltage.

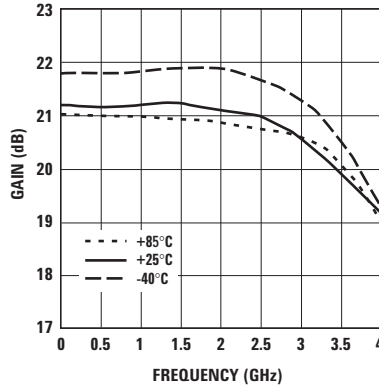

Figure 3. Gain vs. Frequency and Temperature.

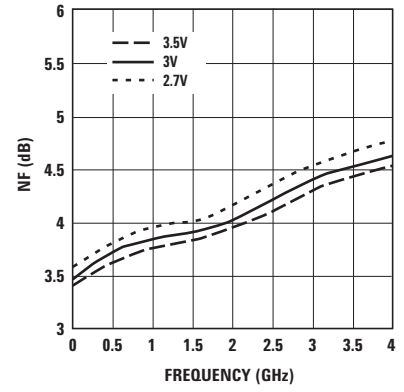

Figure 4. Noise Figure vs. Frequency and Voltage.

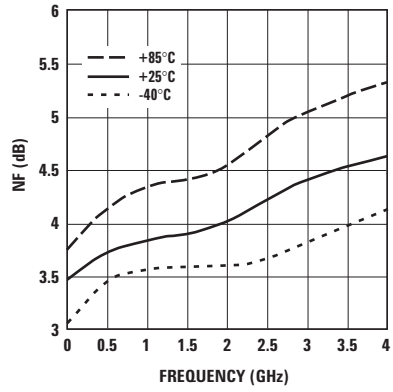

Figure 5. Noise Figure vs. Frequency and Temperature.

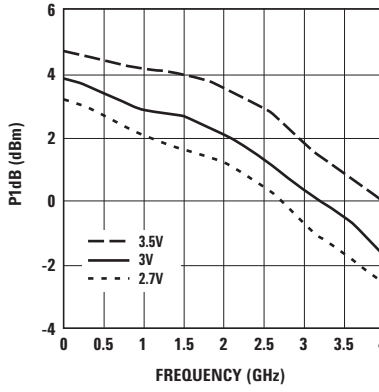

Figure 6. Output Power for 1 dB Gain Compression vs. Frequency and Voltage.

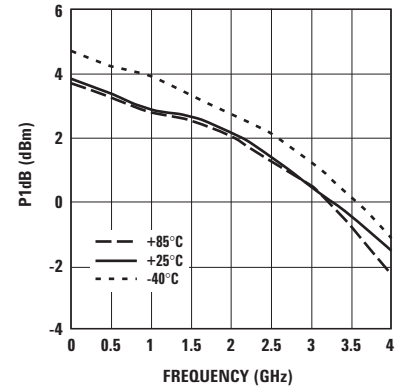
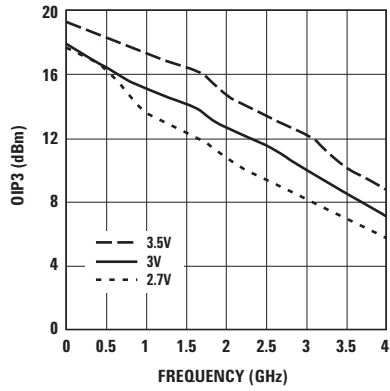

Figure 7. Output Power for 1 dB Gain Compression vs. Frequency and Temperature.

**ABA-31563 Typical Performance, continued**

$T_c = +25^\circ\text{C}$ ,  $Z_o = 50\Omega$ ,  $V_{cc} = 3\text{V}$  unless stated otherwise.



**Figure 8. Output IP3 vs. Frequency and Voltage.**

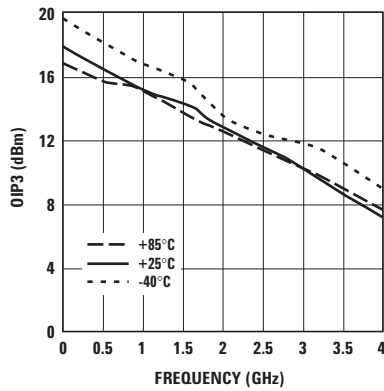

**Figure 9. Output IP3 vs. Frequency and Temperature.**

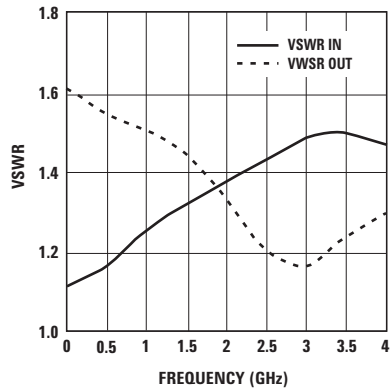

**Figure 10. Input and Output VSWR vs. Frequency.**

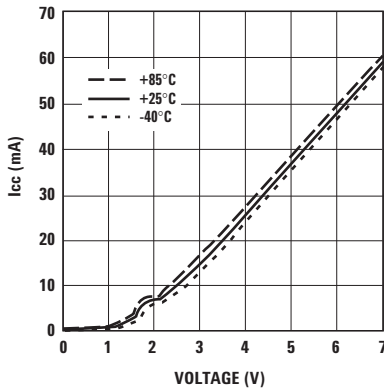

**Figure 11. Supply Current vs. Voltage and Temperature.**

### ABA-31563 Typical Scattering Parameters

$T_C = +25^\circ\text{C}$ ,  $Z_0 = 50\Omega$ ,  $V_{CC} = 3\text{V}$ , unless stated otherwise

Freq (GHz)	S <sub>11</sub> Mag.	S <sub>11</sub> Ang.	S <sub>21</sub> dB	S <sub>21</sub> Mag.	S <sub>21</sub> Ang.	S <sub>12</sub> Mag.	S <sub>12</sub> Ang.	S <sub>22</sub> Mag.	S <sub>22</sub> Ang.	K Factor
0.10	0.05	3.1	21.25	11.54	-4.1	0.03	-0.6	0.23	-4.9	1.800
0.20	0.06	1.6	21.26	11.56	-8.3	0.03	-0.7	0.23	-9.3	1.800
0.30	0.06	1.1	21.28	11.59	-12.5	0.02	-0.6	0.23	-13.6	1.800
0.40	0.06	0.3	21.31	11.62	-16.9	0.02	-0.4	0.23	-18.0	1.800
0.50	0.07	18.4	21.3	11.62	-21.7	0.02	-0.4	0.21	-18.4	1.800
0.60	0.08	21.0	21.3	11.61	-26.3	0.02	0.0	0.21	-20.1	1.900
0.70	0.09	21.0	21.31	11.62	-30.8	0.02	0.8	0.21	-21.9	1.900
0.80	0.10	20.7	21.31	11.62	-35.3	0.02	1.5	0.21	-24.0	1.900
0.90	0.10	18.8	21.32	11.64	-39.8	0.02	2.4	0.20	-26.1	1.900
1.00	0.11	19.2	21.32	11.64	-44.4	0.02	3.2	0.20	-28.1	1.900
1.10	0.12	15.5	21.32	11.65	-48.9	0.02	4.2	0.20	-30.2	1.900
1.20	0.12	14.0	21.32	11.64	-53.4	0.02	5.4	0.20	-32.2	1.900
1.30	0.12	12.4	21.33	11.65	-58.0	0.02	6.5	0.19	-34.6	1.900
1.40	0.13	9.5	21.32	11.64	-62.6	0.02	7.7	0.19	-36.9	1.900
1.50	0.13	7.5	21.35	11.69	-67.2	0.02	8.9	0.18	-39.1	1.900
1.60	0.14	5.0	21.37	11.71	-71.9	0.02	10.2	0.17	-41.2	1.900
1.70	0.14	3.7	21.36	11.70	-76.8	0.02	11.5	0.17	-43.1	1.900
1.80	0.15	0.5	21.36	11.70	-81.4	0.02	12.5	0.16	-44.7	1.900
1.90	0.15	-2.6	21.37	11.71	-86.2	0.02	13.4	0.15	-46.1	1.900
2.00	0.16	-4.2	21.37	11.71	-91.2	0.02	14.8	0.14	-47.8	1.900
2.20	0.17	-9.7	21.33	11.66	-100.7	0.02	16.8	0.12	-48.2	1.800
2.40	0.17	-15.7	21.32	11.64	-110.8	0.03	18.5	0.10	-46.8	1.800
2.60	0.18	-20.1	21.21	11.50	-121.2	0.03	21.0	0.08	-39.7	1.800
2.80	0.19	-27.1	21.1	11.35	-131.2	0.03	21.9	0.07	-23.6	1.700
3.00	0.19	-34.0	20.94	11.15	-141.5	0.03	22.3	0.08	-9.9	1.700
3.20	0.20	-41.7	20.73	10.87	-152.0	0.03	23.2	0.08	0.4	1.700
3.40	0.20	-48.8	20.43	10.51	-162.2	0.03	24.2	0.10	6.3	1.600
3.60	0.20	-57.6	20.12	10.14	-172.3	0.03	24.6	0.11	7.6	1.600
3.80	0.19	-67.0	19.77	9.74	177.7	0.03	25.2	0.12	6.6	1.600
4.00	0.19	-76.0	19.38	9.31	167.9	0.04	25.2	0.13	6.6	1.600
4.20	0.18	-85.5	18.94	8.85	158.6	0.04	25.8	0.14	5.7	1.600
4.40	0.17	-98.2	18.57	8.48	149.1	0.04	24.9	0.14	1.6	1.600
4.60	0.16	-111.5	18.16	8.09	139.4	0.04	24.2	0.14	-2.9	1.600
4.80	0.15	-123.8	17.66	7.64	129.7	0.04	23.2	0.15	-6.5	1.600
5.00	0.14	-136.6	17.08	7.14	120.6	0.05	22.0	0.15	-10.1	1.600
5.20	0.13	-149.9	16.52	6.70	111.9	0.05	20.6	0.15	-15.1	1.600
5.40	0.13	-162.5	15.9	6.24	103.5	0.05	19.2	0.15	-19.7	1.600
5.60	0.14	-175.1	15.37	5.87	95.5	0.06	16.9	0.15	-27.2	1.600
5.80	0.14	170.6	14.81	5.50	87.5	0.06	13.9	0.14	-33.8	1.600
6.00	0.14	164.1	14.22	5.14	80.0	0.06	11.8	0.13	-38.1	1.700

## Device Models

Refer to Agilent's web site  
[www.agilent.com/view/rf](http://www.agilent.com/view/rf)

## Ordering Information

Part Number	Devices per Container	Container
ABA-31563-TR1	3000	7" reel
ABA-31563-TR2	10000	13" reel
ABA-31563-BLK	100	antistatic bag

## Package Dimensions

### Outline 63 (SOT-363/SC-70)

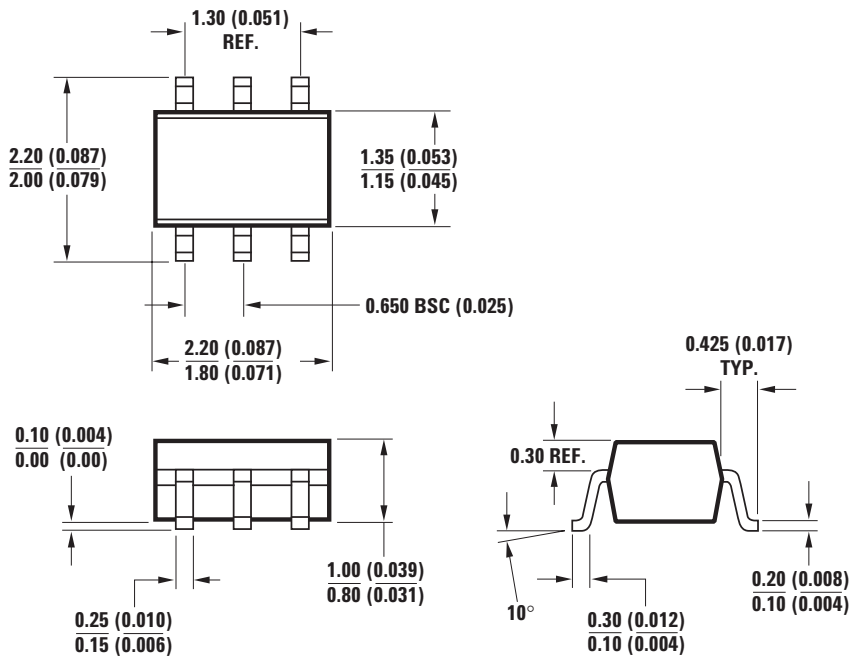

DIMENSIONS ARE IN MILLIMETERS (INCHES)

### Device Orientation

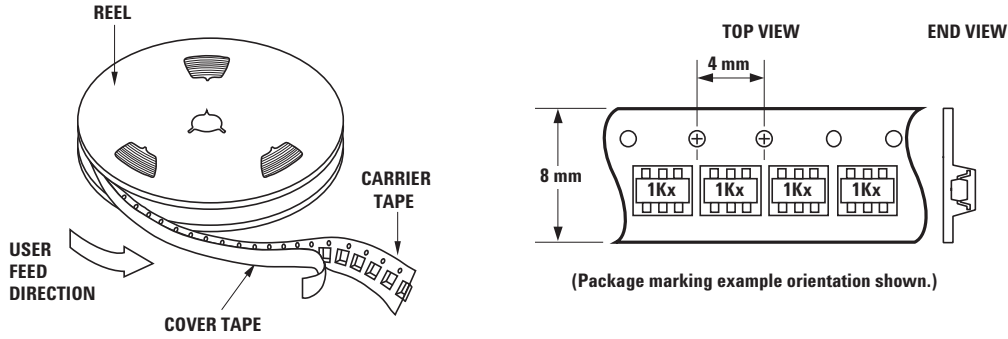

### Tape Dimensions and Product Orientation for Outline 63

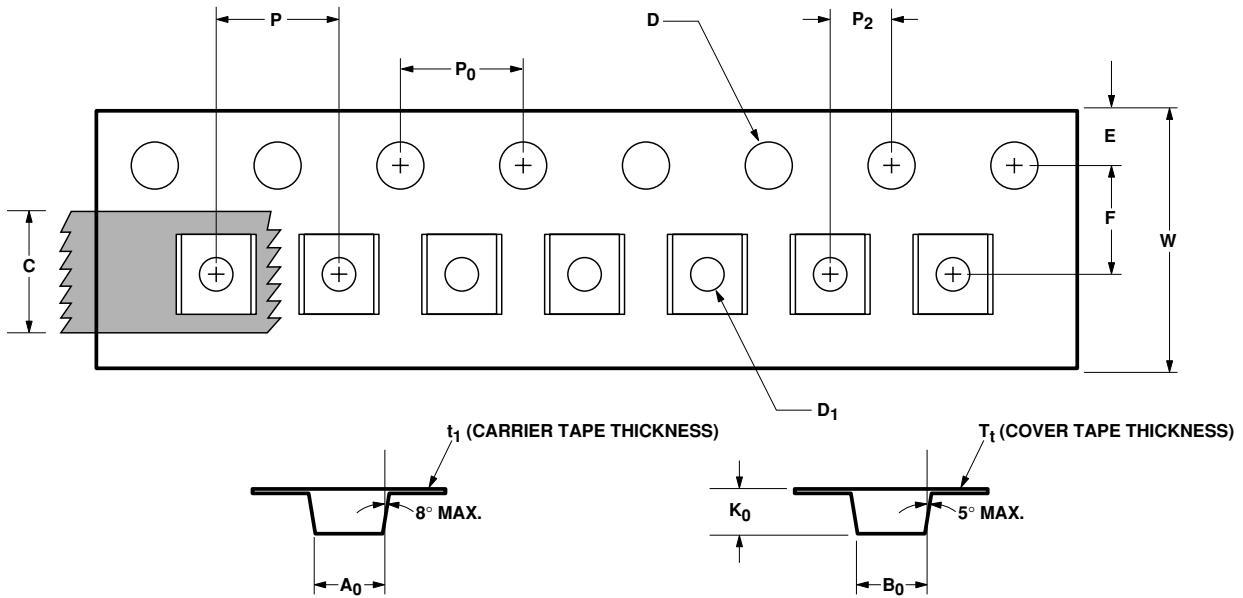

DESCRIPTION		SYMBOL	SIZE (mm)	SIZE (INCHES)
CAVITY	LENGTH	A <sub>0</sub>	2.24 ± 0.10	0.088 ± 0.004
	WIDTH	B <sub>0</sub>	2.34 ± 0.10	0.092 ± 0.004
	DEPTH	K <sub>0</sub>	1.22 ± 0.10	0.048 ± 0.004
	PITCH	P	4.00 ± 0.10	0.157 ± 0.004
	BOTTOM HOLE DIAMETER	D <sub>1</sub>	1.00 ± 0.25	0.039 ± 0.010
PERFORATION	DIAMETER	D	1.55 ± 0.05	0.061 ± 0.002
	PITCH	P <sub>0</sub>	4.00 ± 0.10	0.157 ± 0.004
	POSITION	E	1.75 ± 0.10	0.069 ± 0.004
CARRIER TAPE	WIDTH	W	8.00 ± 0.30	0.315 ± 0.012
	THICKNESS	t <sub>1</sub>	0.255 ± 0.013	0.010 ± 0.0005
COVER TAPE	WIDTH	C	5.4 ± 0.10	0.205 ± 0.004
	TAPE THICKNESS	T <sub>t</sub>	0.062 ± 0.001	0.0025 ± 0.00004
DISTANCE	CAVITY TO PERFORATION (WIDTH DIRECTION)	F	3.50 ± 0.05	0.138 ± 0.002
	CAVITY TO PERFORATION (LENGTH DIRECTION)	P <sub>2</sub>	2.00 ± 0.05	0.079 ± 0.002

**[www.agilent.com/semiconductors](http://www.agilent.com/semiconductors)**

For product information and a complete list of distributors, please go to our web site.

For technical assistance call:

Americas/Canada: +1 (800) 235-0312 or  
(916) 788-6763

Europe: +49 (0) 6441 92460

China: 10800 650 0017

Hong Kong: (65) 6756 2394

India, Australia, New Zealand: (65) 6755 1939

Japan: (+81 3) 3335-8152(Domestic/International), or  
0120-61-1280(Domestic Only)

Korea: (65) 6755 1989

Singapore, Malaysia, Vietnam, Thailand, Philippines,  
Indonesia: (65) 6755 2044

Taiwan: (65) 6755 1843

Data subject to change.

Copyright © 2004 Agilent Technologies, Inc.

April 7, 2004

5989-0755EN



**Agilent Technologies**