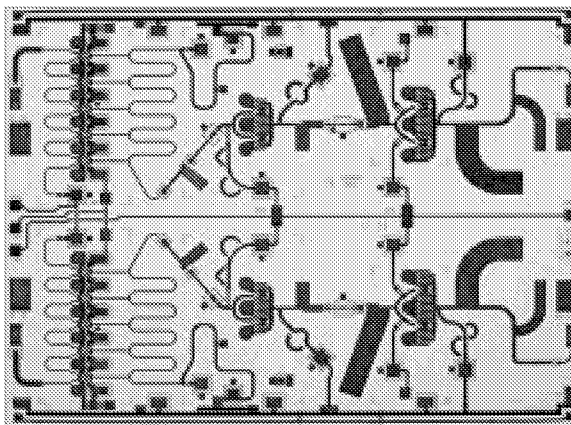

- **6 to 17-GHz Frequency Range**
- **Dual-Channel Power Amplifier**
- **20.5-dB Typical Gain, Single Channel**
- **1.5:1 Typical Input SWR, 2.1:1 Typical Output SWR, Single Channel**
- **29.5-dBm Output Power at 3-dB Gain Compression, (31-dBm combined)**
- **6,5024 x 4,8006 x 0,1016 mm (0.256 x 0.189 x 0.004 in.)**

PHOTO ENLARGEMENT**DESCRIPTION**

The Texas Instruments TGA6316-EEU is a dual channel GaAs monolithic amplifier which operates from 6 to 17-GHz. Each channel features three-stage topology with a 1200- μm dual-gate FET distributed amplifier for the first stage, a 1200- μm single-gate FET second stage, and a 1900- μm single-gate FET third stage. The dual-channel construction is designed for off-chip combining. A single channel of the TGA6316-EEU provides 20.5-dB typical small-signal gain and 29.5-dBm output power at 3-dB gain compression. The TGA6316-EEU amplifier is designed for use in wideband systems such as electronic warfare, expendable decoys and test equipment.

Bond pad and backside metallization is gold plated for compatibility with eutectic alloy attachment methods as well as the thermocompression and thermosonic wire bonding processes. Ground is provided to the circuitry through vias to the backside metallization.

**TYPICAL
OUTPUT POWER FOR
SINGLE CHANNEL**

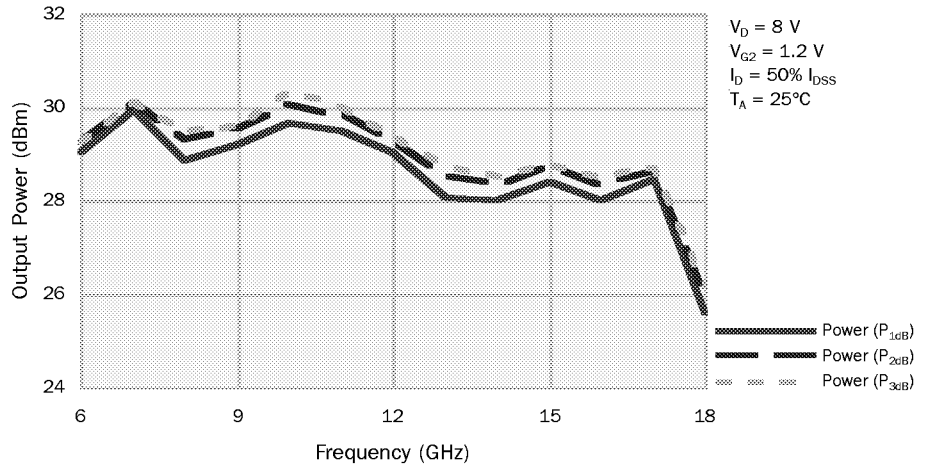

**TYPICAL
SMALL-SIGNAL
POWER GAIN
FOR SINGLE CHANNEL**

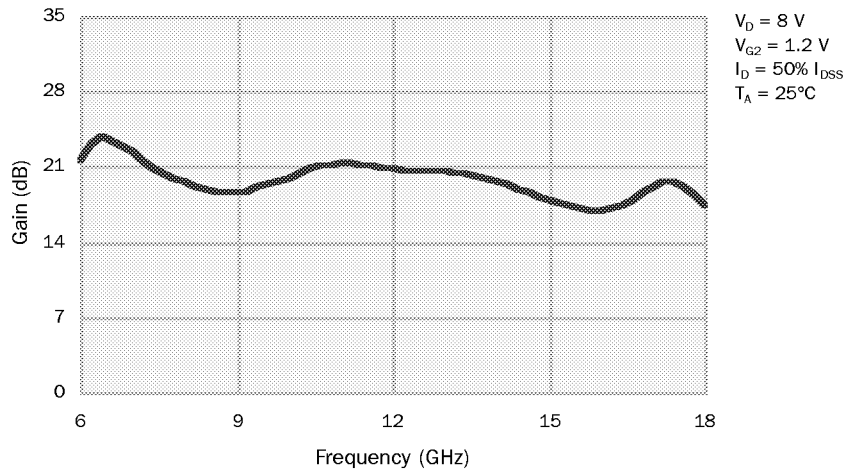

**TYPICAL
RETURN LOSS
FOR SINGLE CHANNEL**

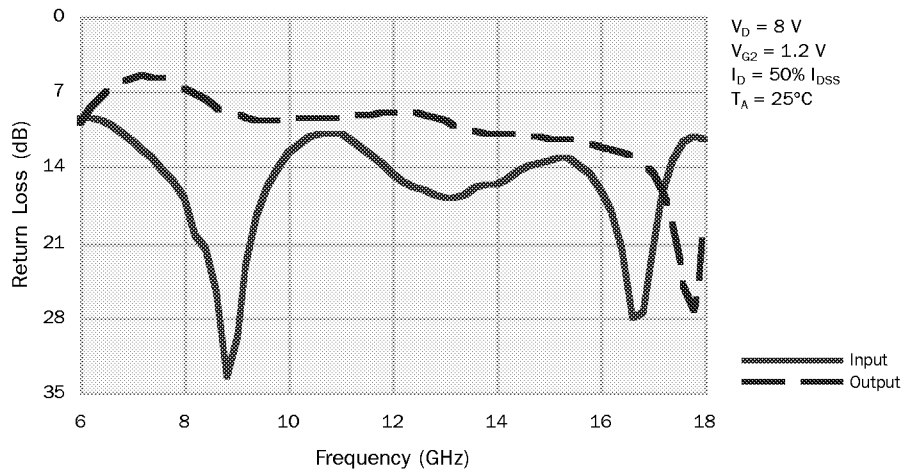

**ABSOLUTE
MAXIMUM RATINGS**

Positive supply voltage, V_D	9 V
Negative supply voltage range, V_{G1}	-5 V to 0 V
Positive supply voltage range (with respect to negative supply voltage, $V_D - V_{G1}$)	0 V to 10 V
Gain control voltage range, V_{G2}	-5 V to 4 V
Gain control voltage range (with respect to positive supply voltage, $V_{G2} - V_D$)	0 V to -10 V
Positive supply current, I_D	I_{DSS}
Power dissipation, at (or below) 25°C base-plate temperature (single channel), P_D^*	10 W
Input continuous wave power, P_{IN} (single channel)	25 dBm
Operating channel temperature, T_{CH}^{**}	150°C
Mounting temperature (30 sec), T_M	320°C
Storage temperature range, T_{STG}	-65 to 150°C

Ratings over operating channel temperature range, T_{CH}

Stresses beyond those listed under “Absolute Maximum Ratings” may cause permanent damage to the device. These are stress ratings only, and functional operation of the device at these or any other conditions beyond those indicated under “RF Characteristics” is not implied. Exposure to absolute maximum rated conditions for extended periods may affect device reliability.

* For operation above 25°C base-plate temperature, derate linearly at the rate of 21.7 mW/°C.

** Operating channel temperature will directly affect the device MTTF. For maximum life, it is recommended that channel temperature be maintained at the lowest possible level.

TYPICAL S-PARAMETERS

Frequency (GHz)	S ₁₁		S ₂₁		S ₁₂		S ₂₂		GAIN (dB)
	MAG	ANG(°)	MAG	ANG(°)	MAG	ANG(°)	MAG	ANG(°)	
6.0	0.34	-162	11.98	25	0.004	13	0.32	-13	21.6
6.4	0.33	179	15.41	-60	0.001	146	0.43	-57	23.8
6.8	0.29	162	13.82	-131	0.001	136	0.50	-92	22.8
7.2	0.24	150	12.11	170	0.001	127	0.53	-122	21.7
7.6	0.19	138	10.41	122	0.001	126	0.51	-147	20.3
8.0	0.14	126	9.49	77	0.001	135	0.47	-171	19.5
8.4	0.08	117	8.74	37	0.001	136	0.41	171	18.8
8.8	0.02	143	8.54	-2	0.001	126	0.36	156	18.6
9.2	0.07	-126	8.64	-38	0.001	139	0.33	143	18.7
9.6	0.16	-140	9.24	-77	0.001	119	0.33	130	19.3
10.0	0.23	-161	9.89	-116	0.002	124	0.33	114	19.9
10.4	0.28	178	10.93	-158	0.002	81	0.34	97	20.8
10.8	0.29	157	11.42	158	0.002	85	0.34	79	21.2
11.2	0.27	136	11.58	114	0.000	30	0.35	61	21.3
11.6	0.23	122	11.23	71	0.001	23	0.35	41	21.0
12.0	0.19	112	11.05	29	0.001	-75	0.36	21	20.9
12.4	0.16	110	10.76	-12	0.001	-142	0.35	1	20.6
12.8	0.15	108	10.82	-54	0.001	-147	0.34	-20	20.7
13.2	0.14	107	10.48	-97	0.000	124	0.31	-37	20.4
13.6	0.16	107	10.21	-141	0.002	147	0.29	-51	20.2
14.0	0.16	99	9.47	177	0.001	157	0.28	-63	19.5
14.4	0.19	94	8.89	133	0.000	-121	0.28	-78	19.0
14.8	0.21	81	8.09	92	0.001	171	0.27	-91	18.2
15.2	0.22	63	7.56	51	0.000	-105	0.27	-104	17.6
15.6	0.20	43	7.09	11	0.001	-120	0.26	-118	17.0
16.0	0.16	24	7.06	-28	0.002	-142	0.25	-131	17.0
16.4	0.08	13	7.41	-69	0.001	-142	0.24	-144	17.4
16.8	0.04	97	8.52	-115	0.001	-115	0.21	-160	18.6
17.2	0.15	109	9.45	-174	0.001	-174	0.15	-177	19.5
17.6	0.26	78	9.15	121	0.000	-30	0.06	-179	19.2
18.0	0.27	43	7.29	58	0.000	-57	0.11	-84	17.3

T_A = 25°C, V_D = 8 V, V_{g2} = 1.2 V, I_D = 50% I_{DSS} (single channel)

RF CHARACTERISTICS

	PARAMETER	TEST CONDITIONS	TYP	UNITS
G _p	Small-signal power gain	f = 6 to 17 GHz	20.5	dB
SWR(in)	Input standing wave ratio	f = 6 to 17 GHz	1.5:1	-
SWR(out)	Output standing wave ratio	f = 6 to 17 GHz	2.1:1	-
P _{1dB}	Output power at 1-dB gain compression	f = 6 to 17 GHz	28.5	dBm
P _{2dB}	Output power at 2-dB gain compression	f = 6 to 17 GHz	29	
P _{3dB}	Output power at 3-dB gain compression	f = 6 to 17 GHz	29.5	

V_D = 8 V, V_{g2} = 1.2 V, I_D = 50% I_{DSS}, T_A = 25°C (single channel)

DC CHARACTERISTICS

PARAMETER	TEST CONDITIONS	MIN	MAX	UNIT
I_{DSS} Total zero-gate-voltage drain current at saturation	$V_{DS} = 0.5 \text{ V to } 3.5 \text{ V}, V_{GS} = 0$	971	1842	mA

$T_A = 25^\circ\text{C}$ (single channel)

V_{DS} for I_{DSS} is the drain voltage between 0.5 V and 3.5 V at which drain current is highest at DC autoprobe.

EQUIVALENT SCHEMATIC

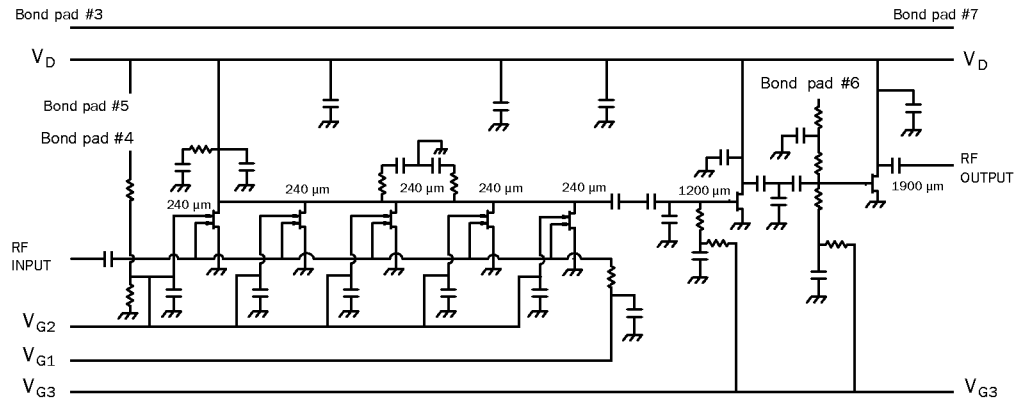

Bond pad #3 and Bond pad #7 are extra transmission lines that can be used for bias routing through a module.

This device offers an optional gate 2 bias for the first stage. Instead of using the V_{G2} pad, bond a wire from Bond pad #4 to Bond pad #5 to apply 1.5 V to gate 2 of the first stage with $V_D = 8 \text{ V}$.

Bond pad #6 is not used.

RECOMMENDED BIAS NETWORK

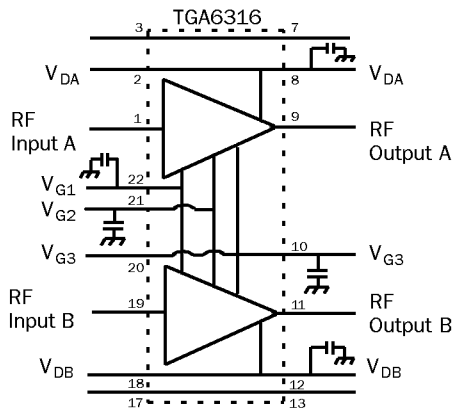

RF connections: Bond using two 1-mil-diameter, 20 to 25-mil-length gold bond wires at both RF Input and RF Output for optimum RF performance.

The capacitors used were 0.01 uF.

Close placement of external components is essential to stability.

Refer to Texas Instruments *Gallium Arsenide Products Designers' Information* on MGP's web site or order literature number GMNA002.

**SINGLE CHANNEL
ASSEMBLY DIAGRAM**

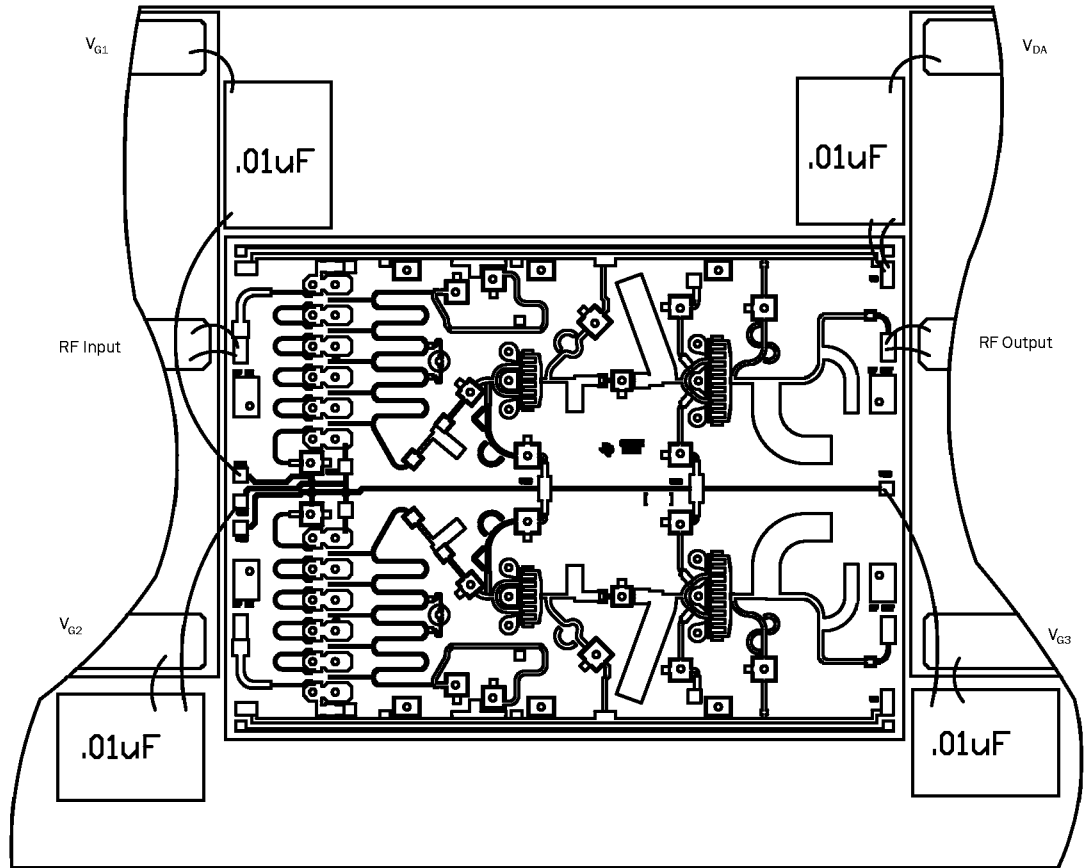

MECHANICAL DRAWING

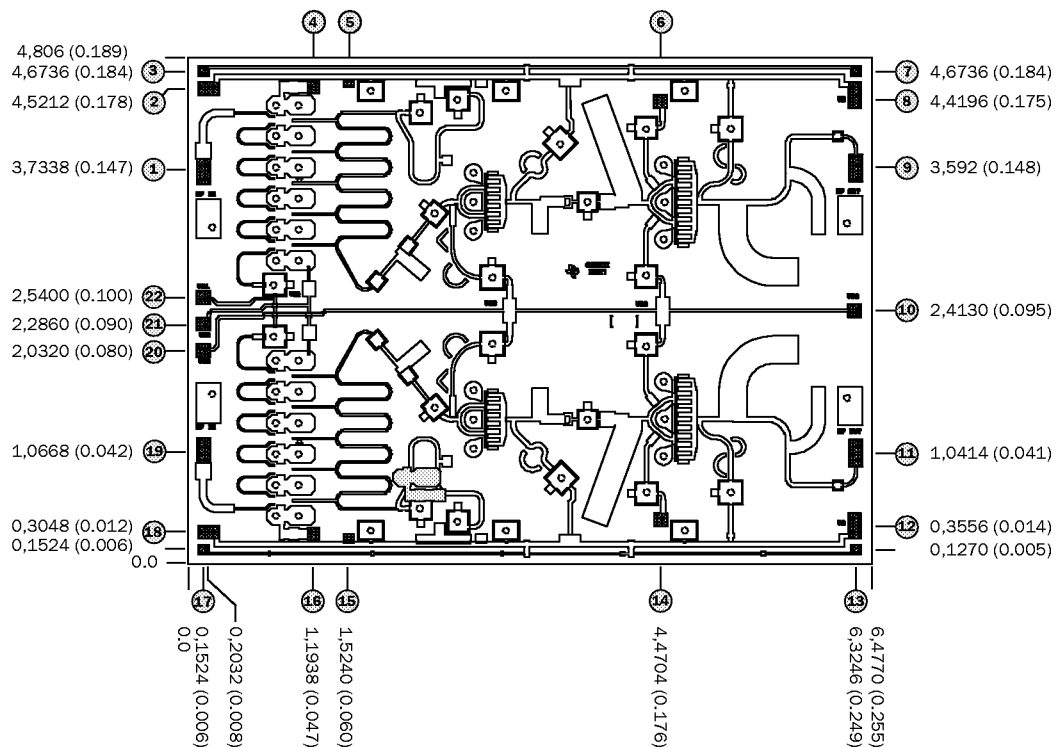

Units: Millimeters (inches)

Thickness: 0,1016 (0.004) (reference only)

Chip edge to bond pad dimensions are shown to center of bond pad.

Chip size $\pm 0,0508$ (0.002)

Bond pad #1, 19 (RF Input):	0,1270 x 0,2311 (0.0050 x 0.0091)
Bond pad #2, 18 (V_D):	0,1981 x 0,1219 (0.0078 x 0.0048)
Bond pad #3, 7, 13, 17:	0,0965 x 0,0965 (0.0039 x 0.0039)
Bond pad #4, 16:	0,1143 x 0,1143 (0.0045 x 0.0045)
Bond pad #5, 15:	0,0991 x 0,0737 (0.0039 x 0.0029)
Bond pad #6, 10, 14, 21, 22, 23:	0,1270 x 0,1270 (0.0050 x 0.0050)
Bond pad #8, 12:	0,1168 x 0,2438 (0.0046 x 0.0096)
Bond pad #9, 11 (RF Output):	0,1321 x 0,2616 (0.0052 x 0.0103)

INTRODUCTION

This section describes the operation of the TGA6316 in a balanced amplifier configuration utilizing Lange Couplers. Bias for V_{G2} is derived from an optional on-chip voltage divider. Bonding pads 4 and 5 together using a 1-mil bond wire provides 1.5 V to V_{G2} with 8 V applied to the drain. The typical output power at 3-dB gain compression for the balanced configuration is 31-dBm at mid-band. A performance comparison between the single-ended and balanced configurations is shown in the Typical Output Power on the next page. The Lange Coupler Layout shown below utilizes 15-mil-thick alumina as the substrate material.

LANGE COUPLER LAYOUT

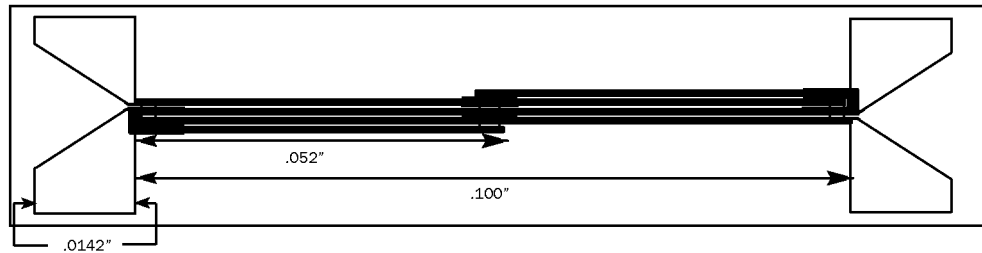

Lange coupled lines: $W = .0011"$, $S = .0009"$.
15-mil Alumina Substrate

TWO LANGE COUPLERS CASCADE ASSEMBLY DIAGRAM

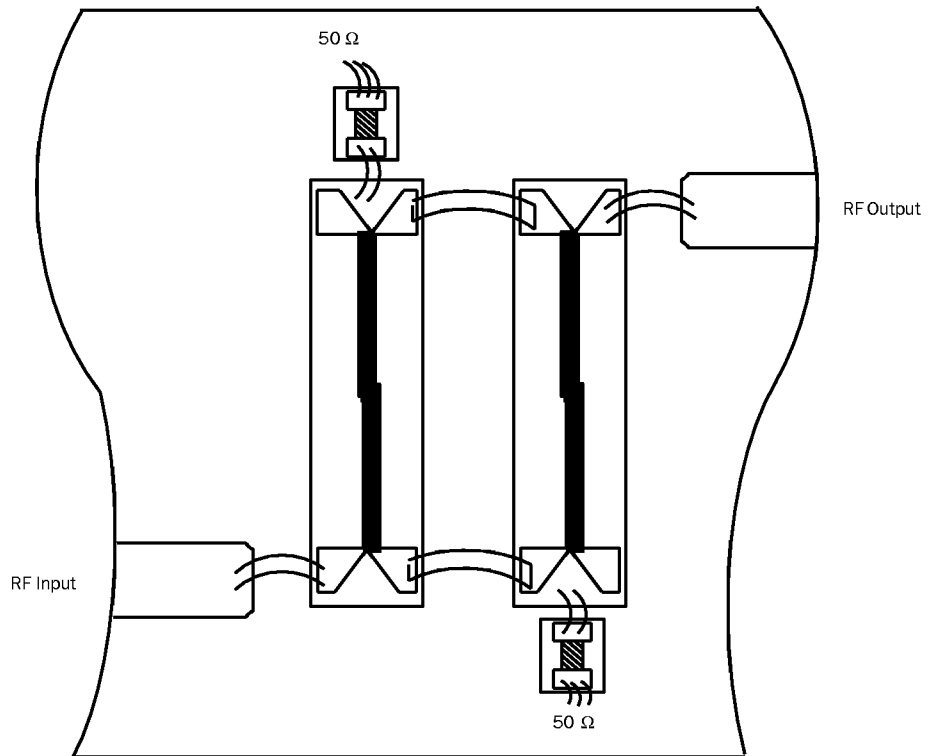

**TYPICAL
OUTPUT POWER**
 P_{3dB}

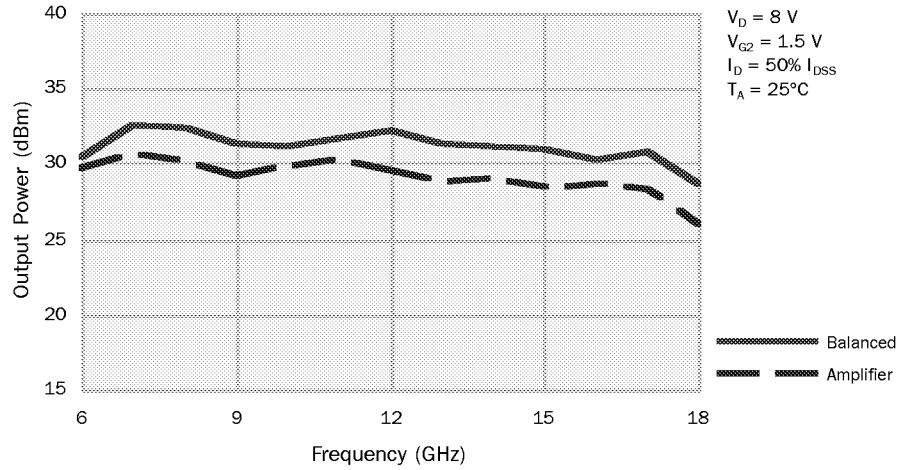

**TYPICAL
INSERTION LOSS
FOR TWO LANGE
COUPLERS**

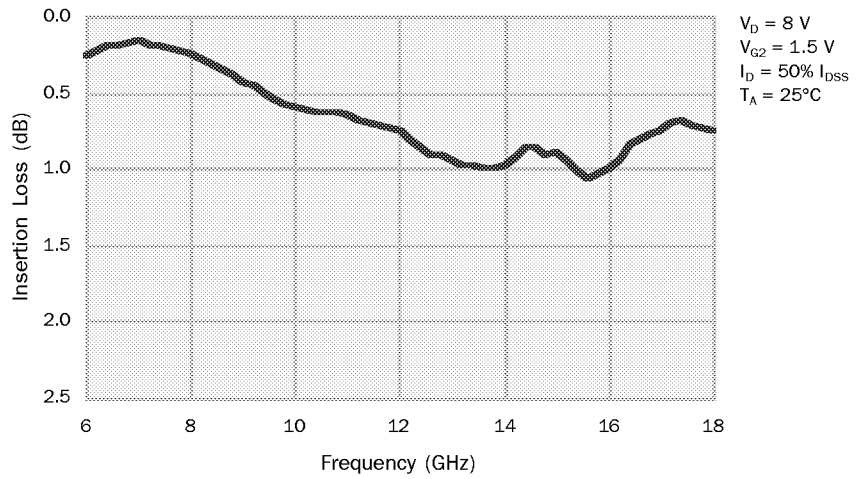

**TYPICAL
RETURN LOSS
FOR LANGE COUPLERS**

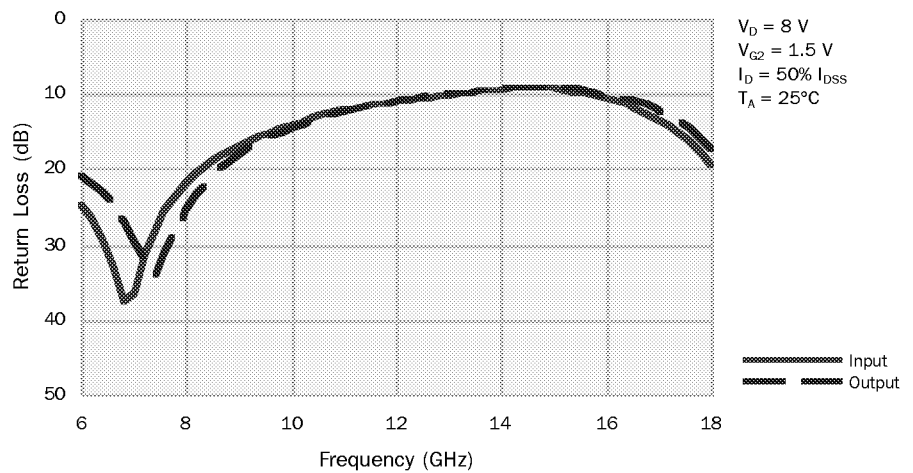

**RECOMMENDED
ASSEMBLY DIAGRAM
FOR BALANCED
CONFIGURATION**

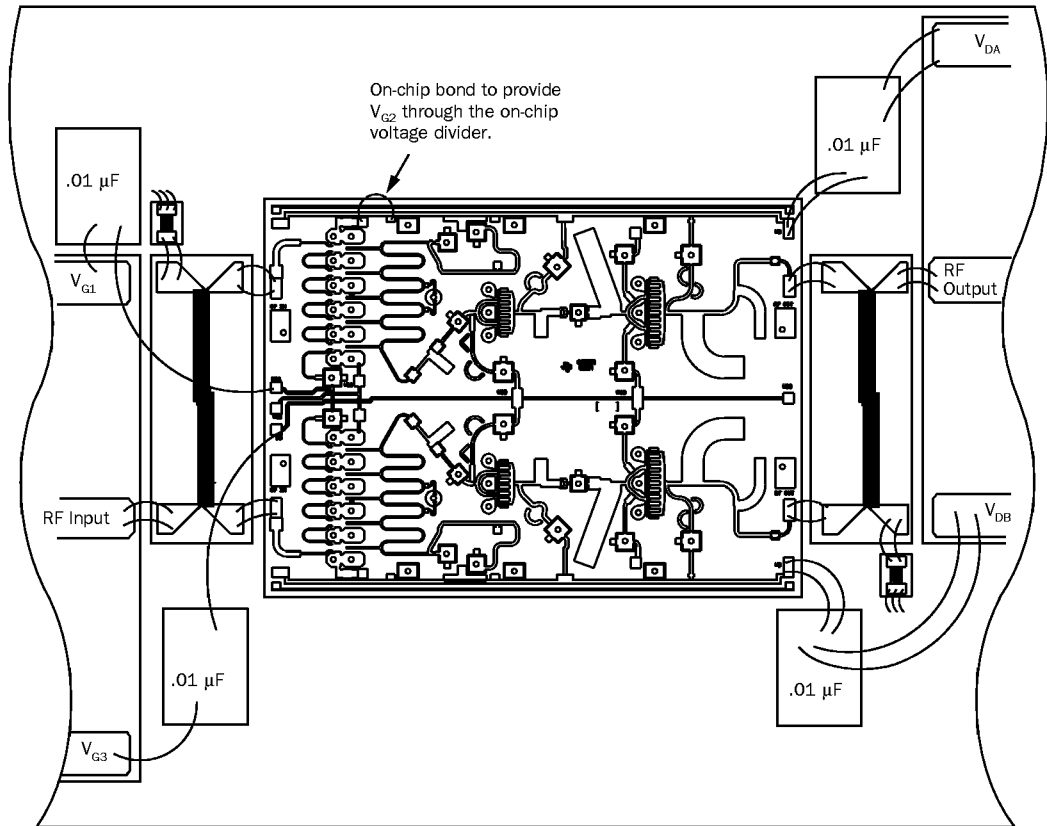

This device is susceptible to damage from electric discharge. Handling and packaging of this device and/or assembly should be accomplished only with adequate provisions to prevent electrostatic discharge damage. **IMPORTANT NOTICE:** Export of this controlled commodity requires appropriate export license authority from the U.S. Government. © Copyright 1996. Texas Instruments Incorporated. All rights reserved.