

CD74HC109, CD74HCT109

Dual J-K̄ Flip-Flop with Set and Reset Positive-Edge Trigger

Features

- Asynchronous Set and Reset
- Schmitt Trigger Clock Inputs
- Typical Propagation Delay = 18ns at $V_{CC} = 5V$, $C_L = 15pF$, $T_A = 25^\circ C$
- Typical $f_{MAX} = 60MHz$ at $V_{CC} = 5V$, $C_L = 15pF$, $T_A = 25^\circ C$
- Fanout (Over Temperature Range)
 - Standard Outputs 10 LSTTL Loads
 - Bus Driver Outputs 15 LSTTL Loads
- Wide Operating Temperature Range . . . $-55^\circ C$ to $125^\circ C$
- Balanced Propagation Delay and Transition Times
- Significant Power Reduction Compared to LSTTL Logic ICs
- HC Types
 - 2V to 6V Operation
 - High Noise Immunity: $N_{IL} = 30\%$, $N_{IH} = 30\%$ of V_{CC}

at $V_{CC} = 5V$

- HCT Types
 - 4.5V to 5.5V Operation
 - Direct LSTTL Input Logic Compatibility, $V_{IL} = 0.8V$ (Max), $V_{IH} = 2V$ (Min)
 - CMOS Input Compatibility, $I_I \leq 1\mu A$ at V_{OL} , V_{OH}

Description

The Harris CD74HC109 and CD74HCT109 are dual J-K̄ flip-flops with set and reset. The flip-flop changes state with the positive transition of Clock (1CP and 2CP).

The flip-flop is set and reset by active-low \bar{S} and \bar{R} , respectively. A low on both the set and reset inputs simultaneously will force both Q and \bar{Q} outputs high. However, both set and reset going high simultaneously results in an unpredictable output condition.

Ordering Information

PART NUMBER	TEMP. RANGE (°C)	PACKAGE	PKG. NO.
-------------	---------------------	---------	-------------

Pinout

CD74HC109, CD74HCT109
(PDIP, SOIC)
TOP VIEW

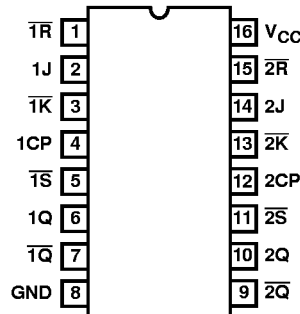

Functional Diagram

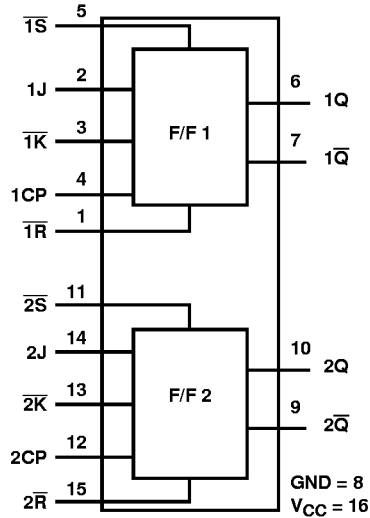

TRUTH TABLE

INPUTS					OUTPUTS	
\bar{S}	\bar{R}	CP	J	\bar{K}	Q	\bar{Q}
L	H	X	X	X	H	L
H	L	X	X	X	L	H
L	L	X	X	X	H (Note 3)	H (Note 3)
H	H	\uparrow	L	L	L	H
H	H	\uparrow	H	L	Toggle	
H	H	\uparrow	L	H	No Change	
H	H	\uparrow	H	H	H	\bar{L}
H	H	L	X	X	No Change	

NOTES:

H= High Level (Steady State)

L= Low Level (Steady State)

X= Don't Care

\uparrow = Low-to-High Transition

3. Unpredictable and unstable condition if both \bar{S} and \bar{R} go high simultaneously.

Logic Diagram

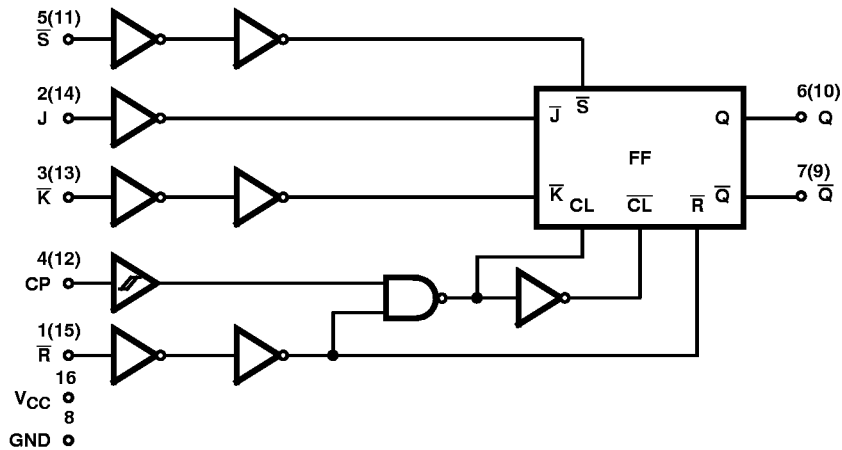

CD74HC109, CD74HCT109

Absolute Maximum Ratings

DC Supply Voltage, V_{CC}	-0.5V to 7V
DC Input Diode Current, I_{IK}	
For $V_I < -0.5V$ or $V_I > V_{CC} + 0.5V$	$\pm 20mA$
DC Drain Current, per Output, I_O	
For $-0.5V < V_O < V_{CC} + 0.5V$	$\pm 25mA$
DC Output Diode Current, I_{OK}	
For $V_O < -0.5V$ or $V_O > V_{CC} + 0.5V$	$\pm 20mA$
DC Output Source or Sink Current per Output Pin, I_{O1}	
For $V_O > -0.5V$ or $V_O < V_{CC} + 0.5V$	$\pm 25mA$
DC V_{CC} or Ground Current, I_{CC}	$\pm 50mA$

Thermal Information

Thermal Resistance (Typical, Note 4)	θ_{JA} ($^{\circ}C/W$)
PDIP Package	90
SOIC Package	160
Maximum Junction Temperature (Hermetic Package or Die) . . .	175 $^{\circ}C$
Maximum Junction Temperature (Plastic Package)	150 $^{\circ}C$
Maximum Storage Temperature Range	-65 $^{\circ}C$ to 150 $^{\circ}C$
Maximum Lead Temperature (Soldering 10s)	300 $^{\circ}C$
(SOIC - Lead Tips Only)	

Operating Conditions

Temperature Range, T_A	-55 $^{\circ}C$ to 125 $^{\circ}C$
Supply Voltage Range, V_{CC}	
HC Types2V to 6V
HCT Types	4.5V to 5.5V
DC Input or Output Voltage, V_I , V_O	0V to V_{CC}
C_p Input Rise and Fall Time, t_r , t_f	
2V	1.0ms (Max)
4.5V	1.0ms (Max)
6V	1.0ms (Max)
Input Rise and Fall Time (All Inputs Except C_p), t_r , t_f	
2V	1000ns (Max)
4.5V	500ns (Max)
6V	400ns (Max)

CAUTION: Stresses above those listed in "Absolute Maximum Ratings" may cause permanent damage to the device. This is a stress only rating and operation of the device at these or any other conditions above those indicated in the operational sections of this specification is not implied.

NOTE:

- θ_{JA} is measured with the component mounted on an evaluation PC board in free air.

DC Electrical Specifications

PARAMETER	SYMBOL	TEST CONDITIONS		V_{CC} (V)	25 $^{\circ}C$			-40 $^{\circ}C$ TO 85 $^{\circ}C$		-55 $^{\circ}C$ TO 125 $^{\circ}C$		UNITS	
		V_I (V)	I_O (mA)		MIN	TYP	MAX	MIN	MAX	MIN	MAX		
HC TYPES													
High Level Input Voltage	V_{IH}	-	-	2	1.5	-	-	1.5	-	1.5	-	V	
				4.5	3.15	-	-	3.15	-	3.15	-	V	
				6	4.2	-	-	4.2	-	4.2	-	V	
Low Level Input Voltage	V_{IL}	-	-	2	-	-	0.5	-	0.5	-	0.5	V	
				4.5	-	-	1.35	-	1.35	-	1.35	V	
				6	-	-	1.8	-	1.8	-	1.8	V	
High Level Output Voltage CMOS Loads	V_{OH}	V_{IH} or V_{IL}	-0.02	2	1.9	-	-	1.9	-	1.9	-	V	
				4.5	4.4	-	-	4.4	-	4.4	-	V	
				6	5.9	-	-	5.9	-	5.9	-	V	
High Level Output Voltage TTL Loads	V_{OH}	V_{IH} or V_{IL}	-	-	-	-	-	-	-	-	-	V	
				-4	4.5	3.96	-	-	3.84	-	3.7	-	V
				-5.2	6	5.48	-	-	5.34	-	5.2	-	V

CD74HC109, CD74HCT109

DC Electrical Specifications (Continued)

PARAMETER	SYMBOL	TEST CONDITIONS		V _{CC} (V)	25°C			-40°C TO 85°C		-55°C TO 125°C		UNITS	
		V _I (V)	I _O (mA)		MIN	TYP	MAX	MIN	MAX	MIN	MAX		
Low Level Output Voltage CMOS Loads	V _{OL}	V _{IH} or V _{IL}	0.02	2	-	-	0.1	-	0.1	-	0.1	V	
				4.5	-	-	0.1	-	0.1	-	0.1	V	
				6	-	-	0.1	-	0.1	-	0.1	V	
Low Level Output Voltage TTL Loads	V _{OL}	V _{IH} or V _{IL}	-	-	-	-	-	-	-	-	-	V	
				4	4.5	-	-	0.26	-	0.33	-	0.4	V
				5.2	6	-	-	0.26	-	0.33	-	0.4	V
Input Leakage Current	I _I	V _{CC} or GND	-	6	-	-	±0.1	-	±1	-	±1	μA	
Quiescent Device Current	I _{CC}	V _{CC} or GND	0	6	-	-	4	-	40	-	80	μA	

HCT TYPES

High Level Input Voltage	V _{IH}	-	-	4.5 to 5.5	2	-	-	2	-	2	-	V
Low Level Input Voltage	V _{IL}	-	-	4.5 to 5.5	-	-	0.8	-	0.8	-	0.8	V
High Level Output Voltage CMOS Loads	V _{OH}	V _{IH} or V _{IL}	-	4.5	4.4	-	-	4.4	-	4.4	-	V
High Level Output Voltage TTL Loads			-0.02	4.5	3.98	-	-	3.84	-	3.7	-	V
Low Level Output Voltage CMOS Loads	V _{OL}	V _{IH} or V _{IL}	-4	4.5	-	-	0.1	-	0.1	-	0.1	V
Low Level Output Voltage TTL Loads			0.02	4.5	-	-	0.26	-	0.33	-	0.4	V
Input Leakage Current	I _I	V _{CC} and GND	4	5.5	-	-	±0.1	-	±1	-	±1	μA
Quiescent Device Current	I _{CC}	V _{CC} or GND	0	5.5	-	-	4	-	40	-	80	μA
Additional Quiescent Device Current Per Input Pin: 1 Unit Load	ΔI _{CC} (Note 5)	V _{CC} - 2.1	-	4.5 to 5.5	-	100	360	-	450	-	490	μA

NOTE:

5. For dual-supply systems theoretical worst case (V_I = 2.4V, V_{CC} = 5.5V) specification is 1.8mA.

HCT Input Loading Table

INPUT	UNIT LOADS
All	0.3

NOTE: Unit Load is ΔI_{CC} limit specified in DC Electrical Specifications table, e.g., 360μA max at 25°C.

CD74HC109, CD74HCT109

Prerequisite For Switching Specifications

PARAMETER	SYMBOL	TEST CONDITIONS	V _{CC} (V)	25°C			-40°C TO 85°C		-55°C TO 125°C		UNITS
				MIN	TYP	MAX	MIN	MAX	MIN	MAX	
HC TYPES											
Setup Time J, \bar{K} , to CP	t _{SU}	-	2	80	-	-	100	-	120	-	ns
			4.5	16	-	-	20	-	24	-	ns
			6	14	-	-	17	-	20	-	ns
Hold Time J, \bar{K} , to CP	t _H	-	2	5	-	-	5	-	5	-	ns
			4.5	5	-	-	5	-	5	-	ns
			6	5	-	-	5	-	5	-	ns
Removal Time \bar{R} , \bar{S} , to CP	t _{REM}	-	2	80	-	-	100	-	120	-	ns
			4.5	16	-	-	20	-	24	-	ns
			6	14	-	-	17	-	20	-	ns
Pulse Width CP, \bar{R} , \bar{S}	t _W	-	2	80	-	-	100	-	120	-	ns
			4.5	16	-	-	20	-	24	-	ns
			6	14	-	-	17	-	20	-	ns
CP Frequency	f _{MAX}	-	2	6	-	-	5	-	4	-	MHz
			4.5	30	-	-	25	-	20	-	MHz
			6	35	-	-	29	-	23	-	MHz
HCT TYPES											
Setup Time J, \bar{K} to CP	t _{SU}	-	4.5	18	-	-	23	-	27	-	ns
Hold Time J, \bar{K} to CP	t _H	-	4.5	3	-	-	3	-	3	-	ns
Removal Time \bar{R} , \bar{S} , to CP	t _{REM}	-	4.5	18	-	-	23	-	27	-	ns
Pulse Width CP, \bar{R} , \bar{S}	t _W	-	4.5	18	-	-	23	-	27	-	ns
CP Frequency	f _{MAX}	-	4.5	27	-	-	22	-	18	-	MHz

Switching Specifications Input t_r, t_f = 6ns

PARAMETER	SYMBOL	TEST CONDITIONS	V _{CC} (V)	25°C			-40°C TO 85°C		-55°C TO 125°C		UNITS
				MIN	TYP	MAX	MIN	MAX	MIN	MAX	
HC TYPES											
Propagation Delay, CP → Q, \bar{Q}	t _{PLH} , t _{PHL}	C _L = 50pF	2	-	-	175	-	220	-	265	ns
		C _L = 50pF	4.5	-	-	35	-	44	-	53	ns
		C _L = 15pF	5	-	14	-	-	-	-	-	ns
		C _L = 50pF	6	-	-	30	-	37	-	45	ns
Propagation Delay, \bar{S} → Q	t _{PLH} , t _{PHL}	C _L = 50pF	2	-	-	120	-	150	-	180	ns
		C _L = 50pF	4.5	-	-	24	-	30	-	36	ns
		C _L = 15pF	5	-	9	-	-	-	-	-	ns
		C _L = 50pF	6	-	-	20	-	26	-	31	ns
Propagation Delay, \bar{S} → \bar{Q}	t _{PLH} , t _{PHL}	C _L = 50pF	2	-	-	155	-	195	-	235	ns
		C _L = 50pF	4.5	-	-	31	-	39	-	47	ns
		C _L = 15pF	5	-	13	-	-	-	-	-	ns
		C _L = 50pF	6	-	-	26	-	33	-	40	ns

CD74HC109, CD74HCT109

Switching Specifications Input $t_r, t_f = 6\text{ns}$ (Continued)

PARAMETER	SYMBOL	TEST CONDITIONS	V _{CC} (V)	25°C			-40°C TO 85°C		-55°C TO 125°C		UNITS
				MIN	TYP	MAX	MIN	MAX	MIN	MAX	
Propagation Delay, $\bar{R} \rightarrow Q$	t_{PLH}, t_{PHL}	$C_L = 50\text{pF}$	2	-	-	185	-	230	-	280	ns
		$C_L = 50\text{pF}$	4.5	-	-	37	-	46	-	56	ns
		$C_L = 15\text{pF}$	5	-	15	-	-	-	-	-	ns
		$C_L = 50\text{pF}$	6	-	-	31	-	39	-	48	ns
Propagation Delay, $\bar{R} \rightarrow \bar{Q}$	t_{PLH}, t_{PHL}	$C_L = 50\text{pF}$	2	-	-	170	-	215	-	255	ns
		$C_L = 50\text{pF}$	4.5	-	-	34	-	43	-	51	ns
		$C_L = 15\text{pF}$	5	-	14	-	-	-	-	-	ns
		$C_L = 50\text{pF}$	6	-	-	29	-	37	-	43	ns
Transition Time	t_{TLH}, t_{THL}	$C_L = 50\text{pF}$	2	-	-	75	-	95	-	110	ns
		$C_L = 50\text{pF}$	4.5	-	-	15	-	19	-	22	ns
		$C_L = 50\text{pF}$	6	-	-	13	-	16	-	19	ns
Input Capacitance	C_I	-	-	-	10	-	10	-	10	pF	
CP Frequency	f_{MAX}	$C_L = 15\text{pF}$	5	-	60	-	-	-	-	MHz	
Power Dissipation Capacitance (Notes 6, 7)	C_{PD}	-	5	-	30	-	-	-	-	pF	
HCT TYPES											
Propagation Delay, $CP \rightarrow Q, \bar{Q}$	t_{PLH}, t_{PHL}	$C_L = 50\text{pF}$	4.5	-	-	40	-	50	-	60	ns
		$C_L = 15\text{pF}$	5	-	17	-	-	-	-	-	ns
Propagation Delay, $\bar{S} \rightarrow Q$	t_{PLH}, t_{PHL}	$C_L = 50\text{pF}$	4.5	-	-	30	-	38	-	45	ns
		$C_L = 15\text{pF}$	5	-	12	-	-	-	-	-	ns
Propagation Delay, $S \rightarrow Q$	t_{PLH}, t_{PHL}	$C_L = 50\text{pF}$	4.5	-	-	45	-	56	-	68	ns
		$C_L = 15\text{pF}$	5	-	19	-	-	-	-	-	ns
Propagation Delay, $\bar{R} \rightarrow Q$	t_{PLH}, t_{PHL}	$C_L = 50\text{pF}$	4.5	-	-	45	-	56	-	68	ns
		$C_L = 15\text{pF}$	5	-	19	-	-	-	-	-	ns
Propagation Delay, $\bar{R} \rightarrow \bar{Q}$	t_{PLH}, t_{PHL}	$C_L = 50\text{pF}$	4.5	-	-	37	-	46	-	56	ns
		$C_L = 15\text{pF}$	5	-	15	-	-	-	-	-	ns
Transition Time (Figure 5)	t_{TLH}, t_{THL}	$C_L = 50\text{pF}$	4.5	-	-	15	-	19	-	22	ns
Input Capacitance	C_I	-	-	-	10	-	10	-	10	pF	
CP Frequency	f_{MAX}	$C_L = 15\text{pF}$	5	-	54	-	-	-	-	MHz	
Power Dissipation Capacitance (Notes 6, 7)	C_{PD}	-	5	-	33	-	-	-	-	pF	

NOTES:

6. C_{PD} is used to determine the dynamic power consumption, per flip-flop.
7. $P_D = C_{PD} V_{CC}^2 f_i + \sum C_L f_o$ where f_i = input frequency, f_o = output frequency, C_L = output load capacitance, V_{CC} = supply voltage.

Test Circuits and Waveforms

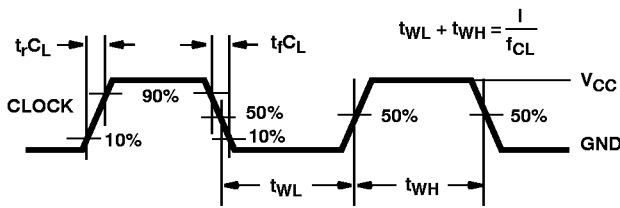

NOTE: Outputs should be switching from 10% V_{CC} to 90% V_{CC} in accordance with device truth table. For f_{MAX} , input duty cycle = 50%.

FIGURE 7. HC CLOCK PULSE RISE AND FALL TIMES AND PULSE WIDTH

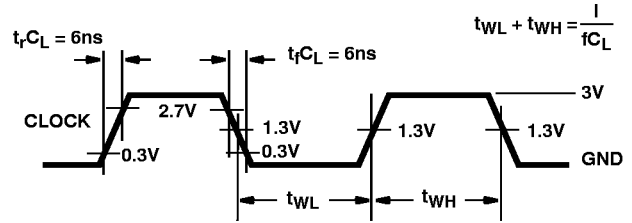

NOTE: Outputs should be switching from 10% V_{CC} to 90% V_{CC} in accordance with device truth table. For f_{MAX} , input duty cycle = 50%.

FIGURE 8. HCT CLOCK PULSE RISE AND FALL TIMES AND PULSE WIDTH

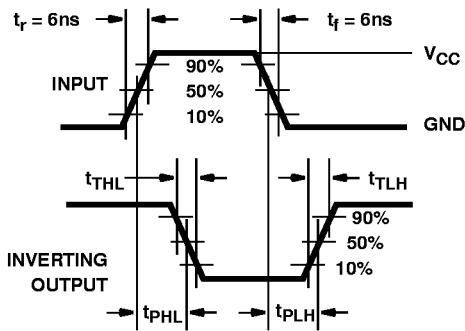

FIGURE 9. HC AND HCU TRANSITION TIMES AND PROPAGATION DELAY TIMES, COMBINATION LOGIC

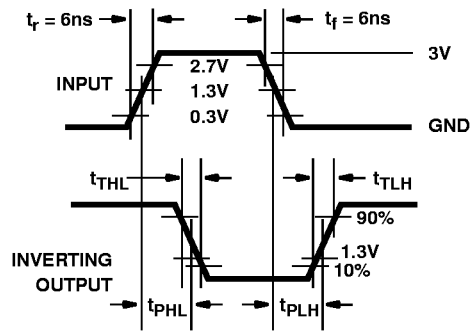

FIGURE 10. HCT TRANSITION TIMES AND PROPAGATION DELAY TIMES, COMBINATION LOGIC

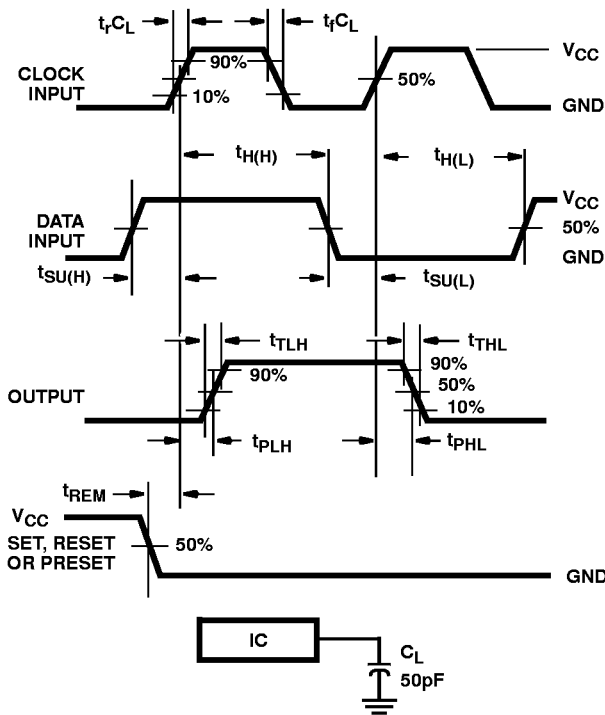

FIGURE 11. HC SETUP TIMES, HOLD TIMES, REMOVAL TIME, AND PROPAGATION DELAY TIMES FOR EDGE TRIGGERED SEQUENTIAL LOGIC CIRCUITS

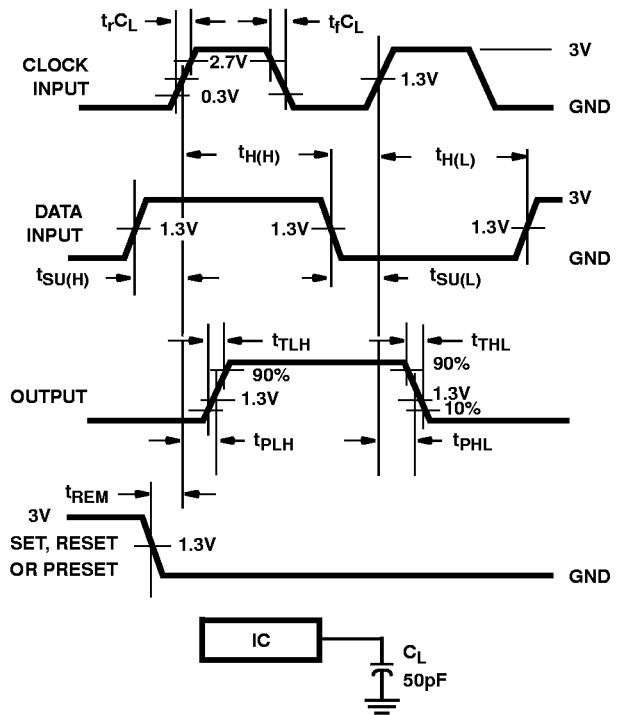

FIGURE 12. HCT SETUP TIMES, HOLD TIMES, REMOVAL TIME, AND PROPAGATION DELAY TIMES FOR EDGE TRIGGERED SEQUENTIAL LOGIC CIRCUITS