

μA716

FIXED-GAIN, LOW DISTORTION AMPLIFIER

FAIRCHILD LINEAR INTEGRATED CIRCUITS

GENERAL DESCRIPTION — The μA716 is a fixed-gain, medium power amplifier intended for use as a telephone system channel amplifier, headset amplifier or a general-purpose audio preamplifier. It provides medium output current capability, low distortion, excellent gain stability, and wide bandwidth. Fixed voltage gains of 10, 20, 100, and 200 are available by selecting external taps.

ABSOLUTE MAXIMUM RATINGS

Supply Voltage	27 V
Internal Power Dissipation (Note 1)	400 mW
Input Voltage	± 5 V
Peak Output Current ($T_A = 25^\circ\text{C}$)	100 mA
Storage Temperature Range	- 65°C to + 150°C
Operating Temperature Range	- 55°C to + 125°C
Lead Temperature (soldering, 60 seconds)	300°C

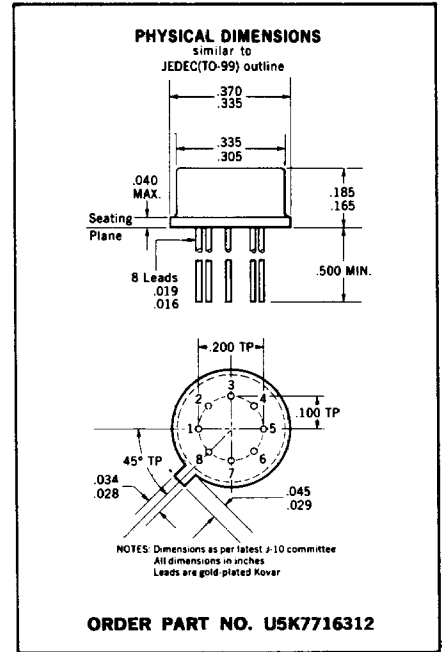

μA716 H.M.

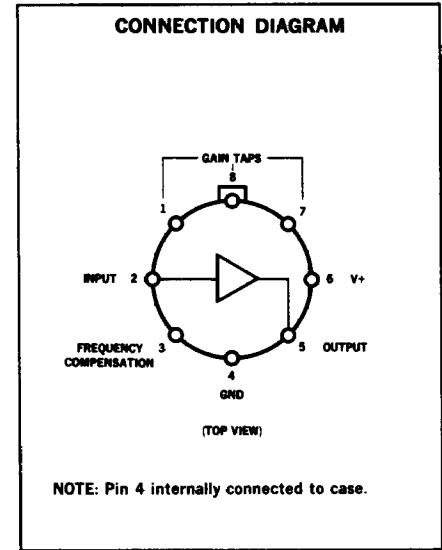
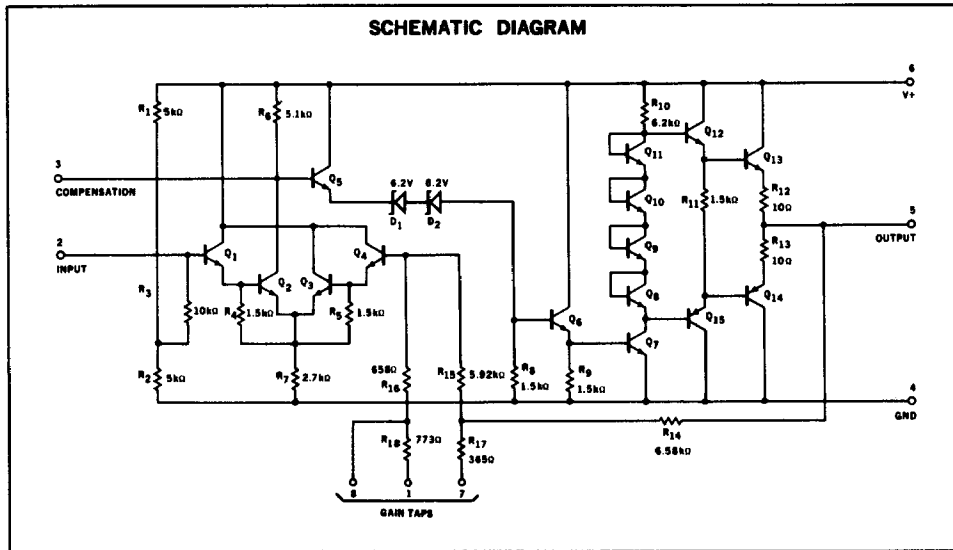

NOTE 1: Rating applies for case temperatures to +125°C; derate linearly at 8.4 mW/°C for ambient temperature above +110°C.

FAIRCHILD LINEAR INTEGRATED CIRCUITS μ A716

ELECTRICAL CHARACTERISTICS ($-55^{\circ}\text{C} \leq T_A \leq +125^{\circ}\text{C}$, $V_+ = 21\text{V}$ unless otherwise specified)

PARAMETER (see definitions)	CONDITIONS	MIN.	TYP.	MAX.	UNITS
Quiescent Power Consumption	$T_A = 25^{\circ}\text{C}$		286	298	mW
	$T_A = 125^{\circ}\text{C}$		244	256	mW
Total Harmonic Distortion	$f = 1\text{ kHz}$, $A_v = 10$, $P_O = 50\text{ mW}$, $R_L = 150\Omega$		0.01	0.05	%
	$f = 1\text{ kHz}$, $A_v = 100$, $P_O = 50\text{ mW}$, $R_L = 150\Omega$		0.10	0.50	%
Input Noise Voltage	$R_s = 600\Omega$, $T_A = 25^{\circ}\text{C}$, $B_n = 16\text{ Hz to } 150\text{ kHz}$		8.0		μV_{rms}
Output Voltage Swing	$R_L = 150\Omega$	10	12		V p-p
	$R_L \geq 5\text{ k}\Omega$	15	17		V p-p
Input Resistance		9.0	11		$\text{k}\Omega$
Output Resistance			1.0		Ω
Voltage Gain					
10x	See Table 1	9.0	10	11	
20x	See Table 1	18	20	22	
100x	See Table 1	95	105	115	
200x	See Table 1	185	205	225	
Bandwidth	$T_A = 25^{\circ}\text{C}$		2.0		MHz
Temperature Stability of Voltage Gain					
	$T_{\text{ref}} = 25^{\circ}\text{C}$				
10x				± 0.50	dB
20x				± 0.50	dB
100x				± 0.50	dB
200x				± 0.65	dB

TYPICAL PERFORMANCE CURVES

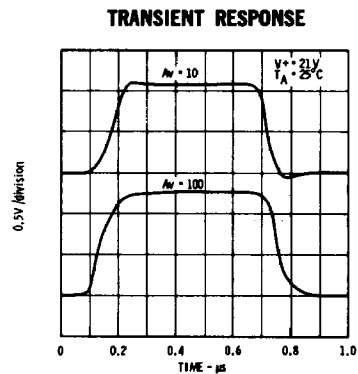
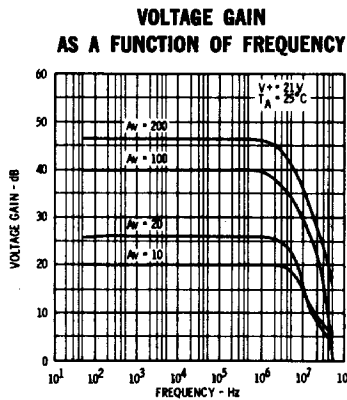

TYPICAL PERFORMANCE CURVES

TOTAL POWER CONSUMPTION AND INTERNAL DEVICE DISSIPATION AS A FUNCTION OF OUTPUT POWER

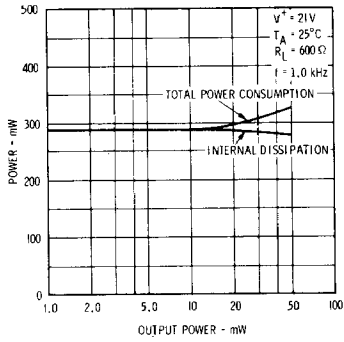

TOTAL HARMONIC DISTORTION AS A FUNCTION OF OUTPUT POWER

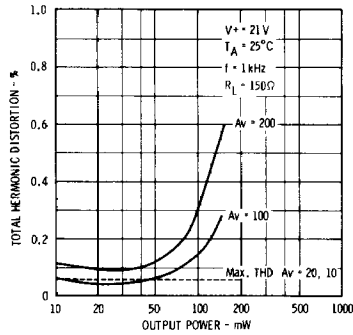

POWER OUTPUT AS A FUNCTION OF FREQUENCY OF FREQUENCY 5% AND 1% TOTAL HARMONIC DISTORTION

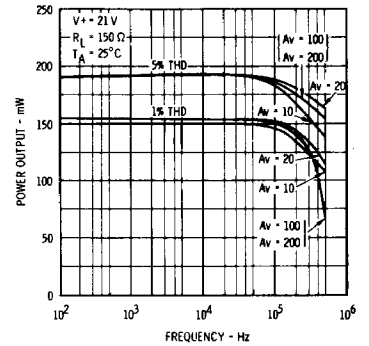

VOLTAGE GAIN AS A FUNCTION OF SUPPLY VOLTAGE

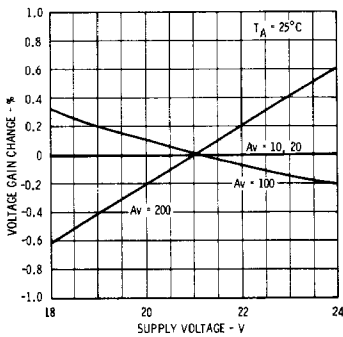

VOLTAGE SWING AS A FUNCTION OF SUPPLY VOLTAGE

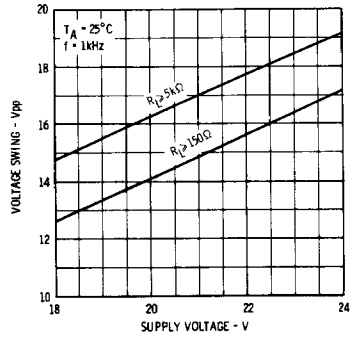

QUIESCENT POWER CONSUMPTION AS A FUNCTION OF SUPPLY VOLTAGE

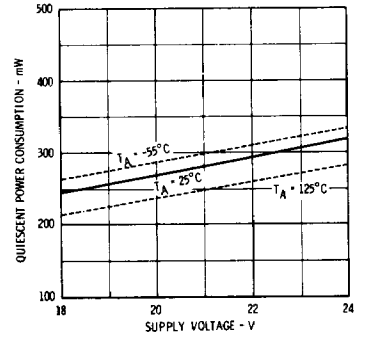

VOLTAGE GAIN AS A FUNCTION OF AMBIENT TEMPERATURE

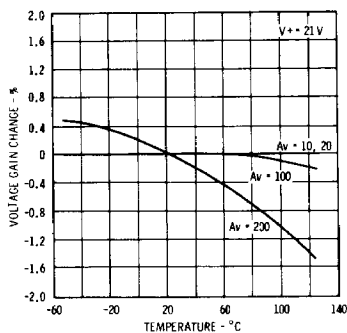

CONNECTION DIAGRAM AND COMPONENT TABLE FOR AVAILABLE GAIN OPTIONS

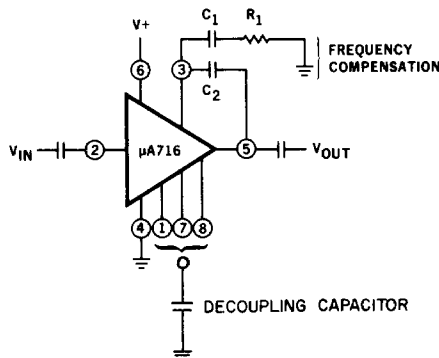

TABLE I

Voltage Gain	C ₁	C ₂	R ₁ Decouple Pins:	
10	68 pF	39 pF	75 Ω	1
20	50 pF	27 pF	75 Ω	8
100	None	3 pF	None	1, 7
200	None	3 pF	None	7, 8

DEFINITION OF TERMS

Quiescent Power Consumption — The DC power required to operate the amplifier with no signal applied at the input and the load current equal to zero.

Total Harmonic Distortion — The ratio of the sum of the amplitudes of all signals harmonically related to the fundamental, and the amplitude of the fundamental signal.

Input Noise Voltage — The noise voltage at the output of the amplifier, divided by the amplifier voltage gain.

Output Voltage Swing — The maximum output voltage that may be obtained at the output of the amplifier before saturation occurs.

Input Resistance — The small-signal resistance seen looking into the input terminal of the amplifier.

Voltage Gain — The ratio of the small-signal output voltage to the input voltage of the amplifier.

Temperature Stability of Voltage Gain — The maximum variation of the voltage gain over the specified temperature range.