

DESCRIPTION

The MH4V7245DATJ is 4194304-word x 72-bit dynamic ram module.

This consist of eighteen industry standard 4M x 4 dynamic RAMs in TSOP and two industry standard 16bits buffers in TSSOP.

The mounting of TSOP on a card edge dual in-line package provides any application where high densities and large of quantities memory are required.

This is a socket-type memory module ,suitable for easy interchange or addition of module.

FEATURES

Type name	/RAS access time (max.ns)	/CAS access time (max.ns)	Address access time (max.ns)	/OE access time (max.ns)	Cycle time (min.ns)	Power dissipation (typ.W)
MH4V7245DATJ-5,5S	50	13	25	13	90	6.94
MH4V7245DATJ-6,6S	60	15	30	15	110	5.86
MH4V7245DATJ-7,7S	70	20	35	20	130	5.05

- Single 3.3V(+/-0.3V) supply operation
 - Low stand-by power dissipation
 - 32.4mW(Max). CMOS input level
12.96mW(Max)*. CMOS input level
 - Low operation power dissipation
 - MH4V7245DATJ-5,5S. 8.20W(Max)
 - MH4V7245DATJ-6,6S. 6.85W(Max)
 - MH4V7245DATJ-7,7S. 5.86W(Max)
 - All input are directly TTL compatible
 - All output are three-state and directly TTL compatible
 - Includes(0.22uF x 20) decoupling capacitors
 - 4096 refresh cycle every 64ms (A0 ~ A11)
 - Hyper page mode(1024-column random address) operation
 - with extended data out
 - JEDEC standard pin configuration & Buffered PD pin.
 - Buffered input except /RAS and DQ.
- *-5S,-6S,-7S

APPLICATION

Main memory unit for computers , Microcomputer memory

PD&ID TABLE

	PD1	PD2	PD3	PD4	PD5	PD6	PD7	PD8	ID0	ID1
-5	1	1	0	1	1	0	0	0	0	0
-5S	1	1	0	1	1	0	0	0	0	1
-6	1	1	0	1	1	1	1	0	0	0
-6S	1	1	0	1	1	1	1	0	0	1
-7	1	1	0	1	1	0	1	0	0	0
-7S	1	1	0	1	1	0	1	0	0	1

1 = NC , 0 = driven to Vss

PD pin . . . buffered. When /PDE is low, PD information can be read

ID pin . . . non-buffered

PIN CONFIGURATION

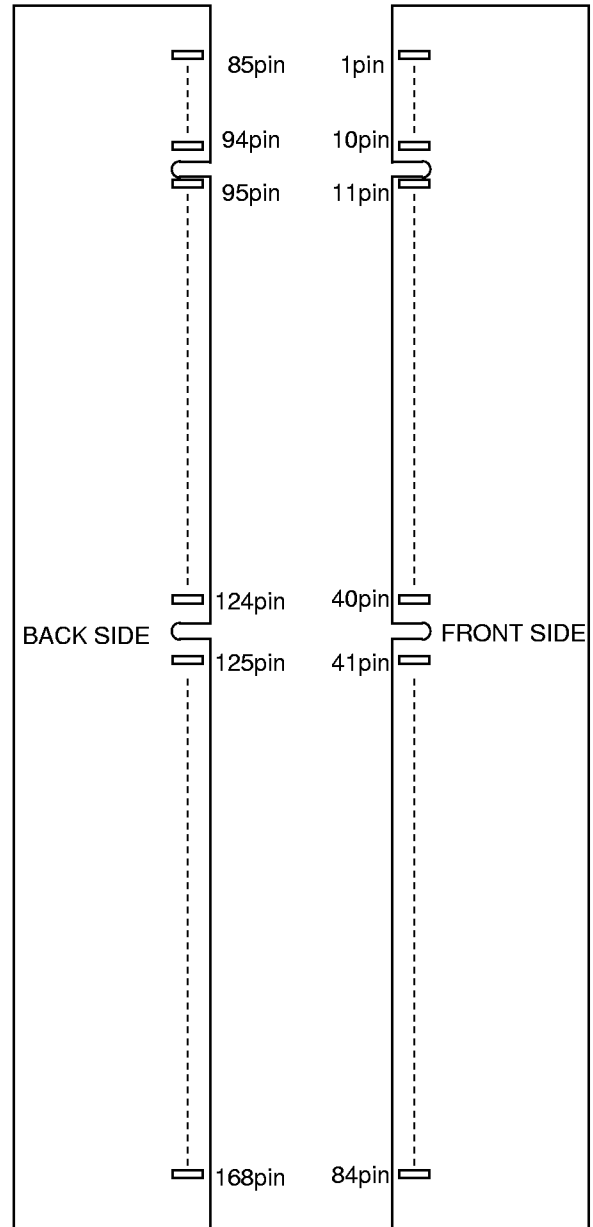

PIN CONFIGURATION

Pin No.	Pin Name	Pin No.	Pin Name	Pin No.	Pin Name	Pin No.	Pin Name
1	Vss	43	Vss	85	Vss	127	Vss
2	DQ0	44	/OE2	86	DQ36	128	RFU
3	DQ1	45	/RAS2	87	DQ37	129	Reserved
4	DQ2	46	/CAS4	88	DQ38	130	Reserved
5	DQ3	47	Reserved	89	DQ39	131	Reserved
6	Vcc	48	/WE2	90	Vcc	132	/PDE
7	DQ4	49	Vcc	91	DQ40	133	Vcc
8	DQ5	50	Reserved	92	DQ41	134	Reserved
9	DQ6	51	Reserved	93	DQ42	135	Reserved
10	DQ7	52	DQ18	94	DQ43	136	DQ54
11	DQ8	53	DQ19	95	DQ44	137	DQ55
12	Vss	54	Vss	96	Vss	138	Vss
13	DQ9	55	DQ20	97	DQ45	139	DQ56
14	DQ10	56	DQ21	98	DQ46	140	DQ57
15	DQ11	57	DQ22	99	DQ47	141	DQ58
16	DQ12	58	DQ23	100	DQ48	142	DQ59
17	DQ13	59	Vcc	101	DQ49	143	Vcc
18	Vcc	60	DQ24	102	Vcc	144	DQ60
19	DQ14	61	RFU	103	DQ50	145	RFU
20	DQ15	62	RFU	104	DQ51	146	RFU
21	DQ16	63	RFU	105	DQ52	147	RFU
22	DQ17	64	RFU	106	DQ53	148	RFU
23	Vss	65	DQ25	107	Vss	149	DQ61
24	Reserved	66	DQ26	108	Reserved	150	DQ62
25	Reserved	67	DQ27	109	Reserved	151	DQ63
26	Vcc	68	Vss	110	Vcc	152	Vss
27	/WE0	69	DQ28	111	RFU	153	DQ64
28	/CAS0	70	DQ29	112	Reserved	154	DQ65
29	Reserved	71	DQ30	113	Reserved	155	DQ66
30	/RAS0	72	DQ31	114	Reserved	156	DQ67
31	/OE0	73	Vcc	115	RFU	157	Vcc
32	Vss	74	DQ32	116	Vss	158	DQ68
33	A0	75	DQ33	117	A1	159	DQ69
34	A2	76	DQ34	118	A3	160	DQ70
35	A4	77	DQ35	119	A5	161	DQ71
36	A6	78	Vss	120	A7	162	Vss
37	A8	79	PD1	121	A9	163	PD2
38	A10	80	PD3	122	A11	164	PD4
39	Reserved	81	PD5	123	Reserved	165	PD6
40	Vcc	82	PD7	124	Vcc	166	PD8
41	RFU	83	ID0	125	RFU	167	ID1
42	RFU	84	Vcc	126	B0	168	Vcc

Reserved: Reserved use

RFU: Reserved for future use

BLOCK DIAGRAM

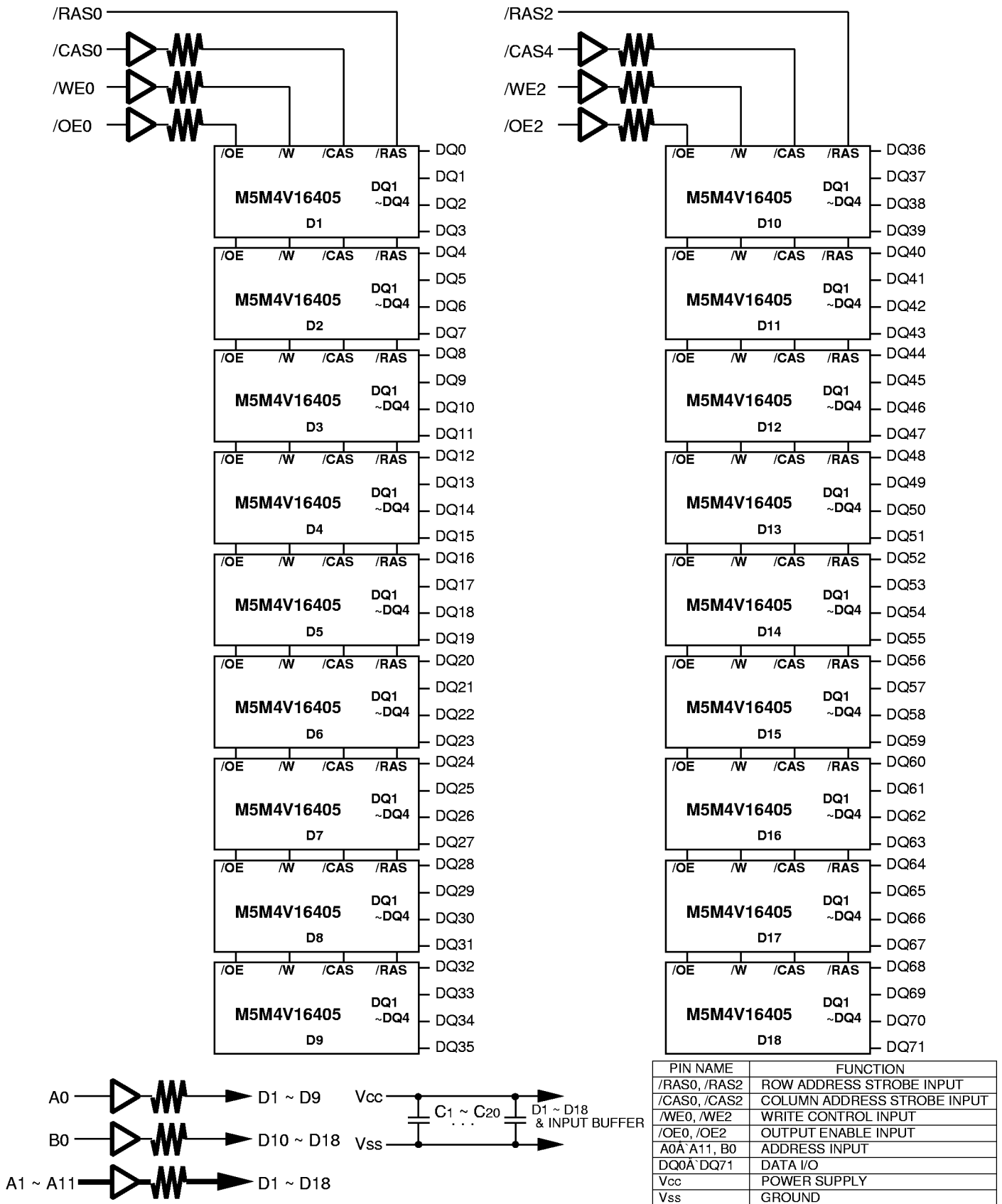

FUNCTION

The MH4V7245DATJ provide, in addition to normal read, write, and read-modify-write operations,

a number of other functions, e.g., Hyper page mode, /RAS-only refresh, and delayed-write. The input conditions for each are shown in Table 1.

Table 1 Input conditions for each mode

Operation	Inputs						Input/Output		Refresh	Remark
	/RAS	/CAS	/W	/OE	Row address	Column address	Input	Output		
Read	ACT	ACT	NAC	ACT	APD	APD	OPN	VLD	YES	Hyper page mode identical
Write (Early write)	ACT	ACT	ACT	DNC	APD	APD	VLD	OPN	YES	
Write (Delayed write)	ACT	ACT	ACT	DNC	APD	APD	VLD	IVD	YES	
Read-modify-write	ACT	ACT	ACT	ACT	APD	APD	VLD	VLD	YES	
/RAS-only refresh	ACT	NAC	DNC	DNC	APD	DNC	DNC	OPN	YES	
Hidden refresh	ACT	ACT	NAC	ACT	APD	DNC	OPN	VLD	YES	
/CAS before /RAS refresh	ACT	ACT	NAC	DNC	DNC	DNC	DNC	OPN	YES	
Standby	NAC	DNC	DNC	DNC	DNC	DNC	DNC	OPN	NO	

Note : ACT : active, NAC : nonactive, DNC : don't care, VLD : valid, IVD : Invalid, APD : applied, OPN : open

ABSOLUTE MAXIMUM RATINGS

Symbol	Parameter	Conditions	Ratings	Unit
Vcc	Supply voltage	With respect to Vss	-0.5~4.6	V
IO	Output current		50	mA
Pd	Power dissipation	Ta=25°C	20	W
Topr	Operating temperature		0 ~70	°C
Tstg	Storage temperature (TSOP)		-40 ~125	°C

RECOMMENDED OPERATING CONDITIONS

(Ta=0~70°C, unless otherwise noted) (Note 1)

Symbol	Parameter	Limits			Unit
		Min	Nom	Max	
Vcc	Supply voltage	3.0	3.3	3.6	V
Vss	Supply voltage	0	0	0	V
VIH	High-level input voltage, all inputs	2.0		Vcc+0.3	V
VIL	Low-level input voltage, all inputs	-0.3**		0.8	V

Note 1 : All voltage values are with respect to Vss

** : VIL(Min) is -2.0V when pulse width is less than 25ns. (Pulse width is with respect to Vss)

ELECTRICAL CHARACTERISTICS (Ta=0~ 70°C, Vcc=3.3V±0.3V, Vss=0V, unless otherwise noted) (Note 2)

Symbol	Parameter	Test conditions	Limits			Unit
			Min	Typ	Max	
VOH	High-level output voltage	IOH=-2.0mA	2.4		Vcc	V
VOL	Low-level output voltage	IOL=2.0mA	0		0.4	V
IOZ	Off-state output current	Q floating 0V ≤ VOUT ≤ 3.6V	-10		10	µA
II	Input current	0V ≤ VIN ≤ 3.6V, Other input pins=0V	-90		90	µA
ICC1 (AV)	Average supply current from Vcc operating (Note 3,4,5)	-5,5S /RAS, /CAS cycling tRC=tWC=min. output open			1987	mA
					1627	
					1357	
ICC2	Supply current from Vcc, stand-by	/RAS=/CAS =VIH, output open			43	mA
		/RAS=/CAS ≥ Vcc -0.2, output open			16	
ICC3 (AV)	Average supply current from Vcc refreshing (Note 3,5)	-5,5S /RAS cycling, /CAS= VIH tRC=min. output open			1987	mA
					1627	
					1357	
ICC4(AV)	Average supply current from Vcc Hyper-Page-Mode (Note 3,4,5)	-5,5S /RAS=VIL,/CAS cycling tPC=min. output open			2527	mA
					2077	
					1627	
ICC6(AV)	Average supply current from Vcc /CAS before /RAS refresh mode (Note 3,5)	-5,5S /CAS before /RAS refresh cycling tRC=min. output open			1987	mA
					1627	
					1357	

Note 2: Current flowing into an IC is positive, out is negative.

3: Icc1 (AV), Icc3 (AV), Icc4 (AV) and Icc6 (AV) are dependent on cycle rate. Maximum current is measured at the fastest cycle rate.

4: Icc1 (AV) and Icc4 (AV) are dependent on output loading. Specified values are obtained with the output open.

5: Under condition of column address being changed once or less while /RAS=VIL and /CAS=VOH

CAPACITANCE (Ta = 0~70°C, Vcc = 3.3V±0.3V, Vss = 0V, unless otherwise noted)

Symbol	Parameter	Test conditions	Limits			Unit
			Min	Typ	Max	
CI (/RAS)	Input capacitance, /RAS input	VI=Vss			60	pF
CI	Input capacitance, except /RAS input	f=1MHZ			19	pF
C(DQ)	Input/Output capacitance, DATA	VI=25mVrms			22	pF

SWITCHING CHARACTERISTICS (Ta=0~ 70°C, Vcc=3.3V+/-0.3V, Vss=0V, unless otherwise noted, see notes 6,14,15)

Symbol	Parameter	Limits						Unit
		-5,5S		-6,6S		-7,7S		
		Min	Max	Min	Max	Min	Max	
tCAC	Access time from /CAS (Note 7,8)		18		20		25	ns
tRAC	Access time from /RAS (Note 7,9)		50		60		70	ns
tAA	Column address access time (Note 7,10)		30		35		40	ns
tCPA	Access time from /CAS precharge (Note 7,11)		35		40		45	ns
tOEA	Access time from /OE (Note 7)		18		20		25	ns
tOHC	Output hold time /CAS high	10		10		10		ns
tOHR	Output hold time /RAS high (Note 13)	5		5		5		ns
tCLZ	Output low impedance time from /CAS low (Note 7)	10		10		10		ns
tOEZ	Output disable time after /OE high (Note 12)		18		20		25	ns
tWEZ	Output disable time after /WE high (Note 12)		18		20		25	ns
tOFF	Output disable time after /CAS high (Note 12,13)		18		20		25	ns
tREZ	Output disable time after /RAS high (Note 12,13)		13		15		20	ns
tDOH	Output hold time from /CAS low	10		10		10		ns

- Note 6: An initial pause of 500µs is required after power-up followed by a minimum of eight initialization cycles (any combination of cycles containing a /RAS clock such as /RAS-Only refresh).
 Note the /RAS may be cycled during the initial pause. And any 8 /RAS or /RAS /CAS cycles are required after prolonged periods (greater than 64 ms) of /RAS inactivity before proper device operation is achieved.
 7: Measured with a load circuit equivalent to 100pF. The reference levels for measuring of output signals are 2.0(VOH)and 0.8(VOL).
 8: Assumes that tRCD ≥ tRCD(max), tASC ≤ tASC(max) and tCP ≥ tCP(max).
 9: Assumes that tRCD ≤ tRCD(max) and tRAD ≤ tRAD(max). If tRCD or tRAD is greater than the maximum recommended value shown in this table, tRAC will increase by amount that tRCD exceeds the value shown.
 10: Assumes that tRAD ≥ tRAD(max) and tASC ≤ tASC(max).
 11: Assumes that tCP ≤ tCP(max) and tASC ≥ tASC(max).
 12: tOEZ (max), tWEZ(max), tOFF(max) and tREZ(max) defines the time at which the output achieves the high impedance state (IOUT ≤ I+/-10 uA) and is not reference to VOH(min) or VOL(max).
 13: Output is disable after both /RAS and /CAS go to high

TIMING REQUIREMENTS (For Read, Write, Read-Modify-Write ,Refresh, and Hyper-Page Mode Cycles)
 (Ta=0~70°C, Vcc=3.3V+/-0.3V, Vss=0V, unless otherwise noted ,see notes 14,15)

Symbol	Parameter	Limits						Unit
		-5,5S		-6,6S		-7,7S		
		Min	Max	Min	Max	Min	Max	
tREF	Refresh cycle time		64		64		64	ms
tRP	/RAS high pulse width	30		40		50		ns
tRCD	Delay time, /RAS low to /CAS low (Note16)	13	32	15	40	15	45	ns
tCRP	Delay time, /CAS high to /RAS low	10		10		10		ns
tRPC	Delay time, /RAS high to /CAS low	-5		-5		-5		ns
tCPN	/CAS high pulse width	8		10		13		ns
tRAD	Column address delay time from /RAS low (Note17)	8	20	10	25	10	30	ns
tASR	Row address setup time before /RAS low	5		5		5		ns
tASC	Column address setup time before /CAS low (Note18)	0	10	0	13	0	13	ns
tRAH	Row address hold time after /RAS low	3		5		5		ns
tCAH	Column address hold time after /CAS low	8		10		10		ns
tDZC	Delay time, data to /CAS low (Note19)	-5		-5		-5		ns
tDZO	Delay time, data to /OE low (Note19)	-5		-5		-5		ns
tRDD	Delay time, /RAS high to data (Note20)	13		15		20		ns
tCDD	Delay time, /CAS high to data (Note20)	18		20		25		ns
tODD	Delay time, /OE high to data (Note20)	18		20		25		ns
tT	Transition time (Note21)	1	50	1	50	1	50	ns

- Note 14: The timing requirements are assumed tT =2ns.
 15: VIH(min) and VIL(max) are reference levels for measuring timing of input signals.
 16: tRCD(max) is specified as a reference point only. If tRCD is less than tRCD(max), access time is tRAC. If tRCD is greater than tRCD(max), access time is controlled exclusively by tCAC or tAA.
 17: tRAD(max) is specified as a reference point only. If tRAD ≥ tRAD(max) and tASC ≤ tASC(max), access time is controlled exclusively by tAA.
 18: tASC(max) is specified as a reference point only. If tRCD ≥ tRCD(max) and tASC ≥ tASC(max), access time is controlled exclusively by tCAC.
 19: Either tDZC or tDZO must be satisfied.
 20: Either tRDD or tCDD or tODD must be satisfied.
 21: tT is measured between VIH(min) and VIL(max).

Read and Refresh Cycles

Symbol	Parameter	Limits						Unit
		-5,5S		-6,6S		-7,7S		
		Min	Max	Min	Max	Min	Max	
tRC	Read cycle time	90		110		130		ns
tRAS	/RAS low pulse width	50	10000	60	10000	70	10000	ns
tCAS	/CAS low pulse width	8	10000	10	10000	13	10000	ns
tCSH	/CAS hold time after /RAS low	35		43		50		ns
tRSH	/RAS hold time after /CAS low	18		20		25		ns
tRCS	Read Setup time before /CAS low	0		0		0		ns
tRCH	Read hold time after /CAS high (Note 22)	0		0		0		ns
tRRH	Read hold time after /RAS high (Note 22)	-5		-5		-5		ns
tRAL	Column address to /RAS hold time	30		35		40		ns
tCAL	column address to /CAS hold time	13		18		23		ns
tORH	/RAS hold time after /OE low	18		20		25		ns
tOCH	/CAS hold time after /OE low	13		15		20		ns

Note 22: Either tRCH or tRRH must be satisfied for a read cycle.

Write Cycle (Early Write and Delayed Write)

Symbol	Parameter	Limits						Unit
		-5,5S		-6,6S		-7,7S		
		Min	Max	Min	Max	Min	Max	
tWC	Write cycle time	90		110		130		ns
tRAS	/RAS low pulse width	50	10000	60	10000	70	10000	ns
tCAS	/CAS low pulse width	8	10000	10	10000	13	10000	ns
tCSH	/CAS hold time after /RAS low	35		43		50		ns
tRSH	/RAS hold time after /CAS low	18		20		25		ns
tWCS	Write setup time before /CAS low (Note 24)	0		0		0		ns
tWCH	Write hold time after /CAS low	8		10		13		ns
tCWL	/CAS hold time after /W low	8		10		13		ns
tRWL	/RAS hold time after W low	13		15		18		ns
tWP	Write pulse width	8		10		13		ns
tDS	Data setup time before /CAS low or W low	-5		-5		-5		ns
tDH	Data hold time after /CAS low or W low	13		15		20		ns

Read-Write and Read-Modify-Write Cycles

Symbol	Parameter	Limits						Unit
		-5,5S		-6,6S		-7,7S		
		Min	Max	Min	Max	Min	Max	
tRWC	Read write/read modify write cycle time (Note23)	109		133		161		ns
tRAS	/RAS low pulse width	75	10000	89	10000	107	10000	ns
tCAS	/CAS low pulse width	38	10000	44	10000	57	10000	ns
tCSH	/CAS hold time after /RAS low	65		77		94		ns
tRSH	/RAS hold time after /CAS low	43		49		62		ns
tRCS	Read setup time before /CAS low	0		0		0		ns
tCWD	Delay time, /CAS low to /W low (Note24)	28		32		42		ns
tRWD	Delay time, /RAS low to /W low (Note24)	60		72		87		ns
tAWD	Delay time, address to /W low (Note24)	40		47		57		ns
tOEH	/OE hold time after /W low	13		15		20		ns

Note 23: tRWC is specified as tRWC(min)=tRAC(max)+tODD(min)+tRWL(min)+tRP(min)+4t.

24:tWCS, tCWD, tRWD, tAWD and tCPWD are specified as reference points only. If tWCS > tWCS(min) the cycle is an early write cycle and the DQ pins will remain high impedance throughout the entire cycle. If tCWD > tCWD(min), tRWD > tRWD (min), tAWD > tAWD(min) and tCPWD > tCPWD(min) (for Hyper page mode cycle only), the cycle is a read-modify-write cycle and the DQ will contain the data read from the selected address. If neither of the above condition (delayed write) of the DQ (at access time and until /CAS or /OE goes back to VIH) is indeterminate.

HYPER PAGE MODE 301989888-BIT (4194304-BIT BY 72-BIT) DYNAMIC RAM

**Hyper Page Mode Cycle (Read, Early Write, Read -Write, Read-Modify-Write Cycle,
Read Write Mix Cycle, Hi-Z control by /OE or /WE) (Note 25)**

Symbol	Parameter	Limits						Unit
		-5,5S		-6,6S		-7,7S		
		Min	Max	Min	Max	Min	Max	
tHPC	Hyper page mode read/write cycle time	20		25		30		ns
tHPRWC	Hyper page mode read write/read modify write cycle time	57		66		79		ns
tRAS	/RAS low pulse width for read write cycle (Note26)	65	100000	77	100000	92	100000	ns
tCP	/CAS high pulse width (Note27)	8	13	10	16	13	16	ns
tCPRH	/RAS hold time after /CAS precharge	33		38		43		ns
tCPWD	Delay time, /CAS precharge to W low (Note24)	43		50		60		ns
tCHOL	Hold time to maintain the data Hi-Z until /CAS access	7		7		7		ns
tOEPE	/OE Pulse Width (Hi-Z control)	7		7		7		ns
tWPE	/W Pulse Width (Hi-Z control)	7		7		7		ns
tHCWD	Delay time, /CAS low to /W low after read	28		32		42		ns
tHAWD	Delay time, Address to /W low after read	40		47		57		ns
tHPWD	Delay time, /CAS precharge to /W low after read	43		50		60		ns
tHCOD	Delay time, /CAS low to /OE high after read	13		15		20		ns
tHAOD	Delay time, Address to /OE high after read	25		30		35		ns
tHPOD	Delay time, /CAS precharge to /OE high after read	28		33		38		ns

Note 25: All previously specified timing requirements and switching characteristics are applicable to their respective fast page mode cycle.

26: tRAS(min) is specified as two cycles of /CAS input are performed.
27: tCP(max) is specified as a reference point only.

/CAS before /RAS Refresh Cycle (Note 28)

Symbol	Parameter	Limits						Unit
		-5,5S		-6,6S		-7,7S		
		Min	Max	Min	Max	Min	Max	
tCSR	/CAS setup time before /RAS low	10		10		10		ns
tCHR	/CAS hold time after /RAS low	5		5		10		ns
tCAS	/CAS low pulse width	17		17		22		ns
tRSR	Read setup time before /RAS low	10		10		10		ns
tRHR	Read hold time after /RAS low	5		5		10		ns

Note 28: Eight or more /CAS before /RAS cycles instead of eight /RAS cycles are necessary for proper operation of /CAS before /RAS refresh mode.

Hidden Refresh Cycle (Note 29)

Symbol	Parameter	Limits						Unit
		-5,5S		-6,6S		-7,7S		
		Min	Max	Min	Max	Min	Max	
tRSR	Read setup time before RAS low	10		10		10		ns
tRHR	Read hold time after RAS low	5		5		10		ns

Note 29: early write, delayed write, read write or read-modify-write cycle is applicable to hidden refresh cycle. In all cases tRSR and tRHR should be satisfied.

SELF REFRESH SPECIFICATIONS

Self refresh devices are denoted by "S" after speed item, like -5S / -6S / -7S. The other characteristics and requirements than the below are same as normal devices.

ELECTRICAL CHARACTERISTICS (Ta=0~70°C, Vcc=3.3V±0.3V, Vss=0V, unless otherwise noted)

Symbol	Parameter	Test conditions	Limits			Unit
			Min	Typ	Max	
Icc8 (AV)	Average supply current from Vcc Slow - Refresh cycle (note 6)	MH4V7245DATJ(S) CAS before RAS refresh cycling ,or, RAS cycling & CAS ≤ 0.2V OE&WE ≤ 0.2V ,or, OE&WE ≥ Vcc-0.2V A0 ~ A10 ≤ 0.2V ,or, A0 ~ A10 ≥ Vcc-0.2V tREF=128mS output = OPEN tRAS=tRASmin. ~ 1 uS			9	mA
Icc9 (AV)	Average supply current from Vcc Self - Refresh cycle (note 6)	MH4V7245DATJ(S) RAS = CAS ≤ 0.2V output = OPEN			3.6	mA

TIMING REQUIREMENTS (Ta=0~70°C, Vcc=3.3V±0.3V, Vss=0V, unless otherwise noted, See note 14,15)

Symbol	Parameter	Limits						Unit
		-5S		-5S		-5S		
		Min	Max	Min	Max	Min	Max	
tRASS	Self Refresh RAS low pulse width	100		100		100		us
tRPS	Self Refresh RAS high precharge time	90		110		130		ns
tCHS	Self Refresh RAS hold time	-45		-45		-45		ns
tRSR	Read setup time before RAS low	15		15		15		ns
tRHR	Read hold time after RAS low	5		5		10		ns

SELF REFRESH ENTRY & EXIT CONDITIONS

(1) In case of distributed refresh

The last / first full refresh cycles (4K) must be made within tNS / tSN before / after self refresh, on the condition of tNS ≤ 64 ms and tSN ≤ 64 ms.

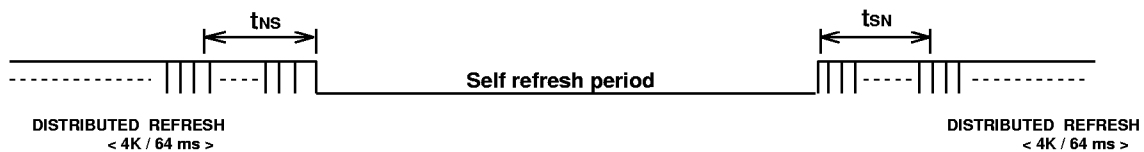

(2) In case of burst refresh

The last / first full refresh cycles (4K) must be made within tNS / tSN before / after self refresh, on the condition of tNS + tSN ≤ 64 ms.

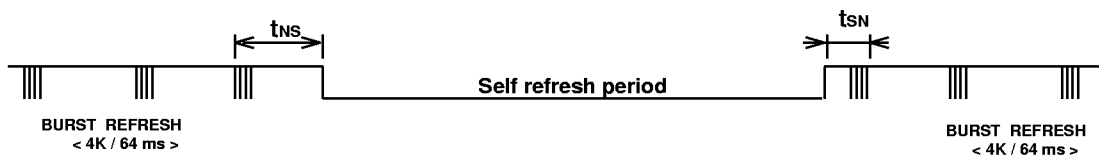

Early Write Cycle

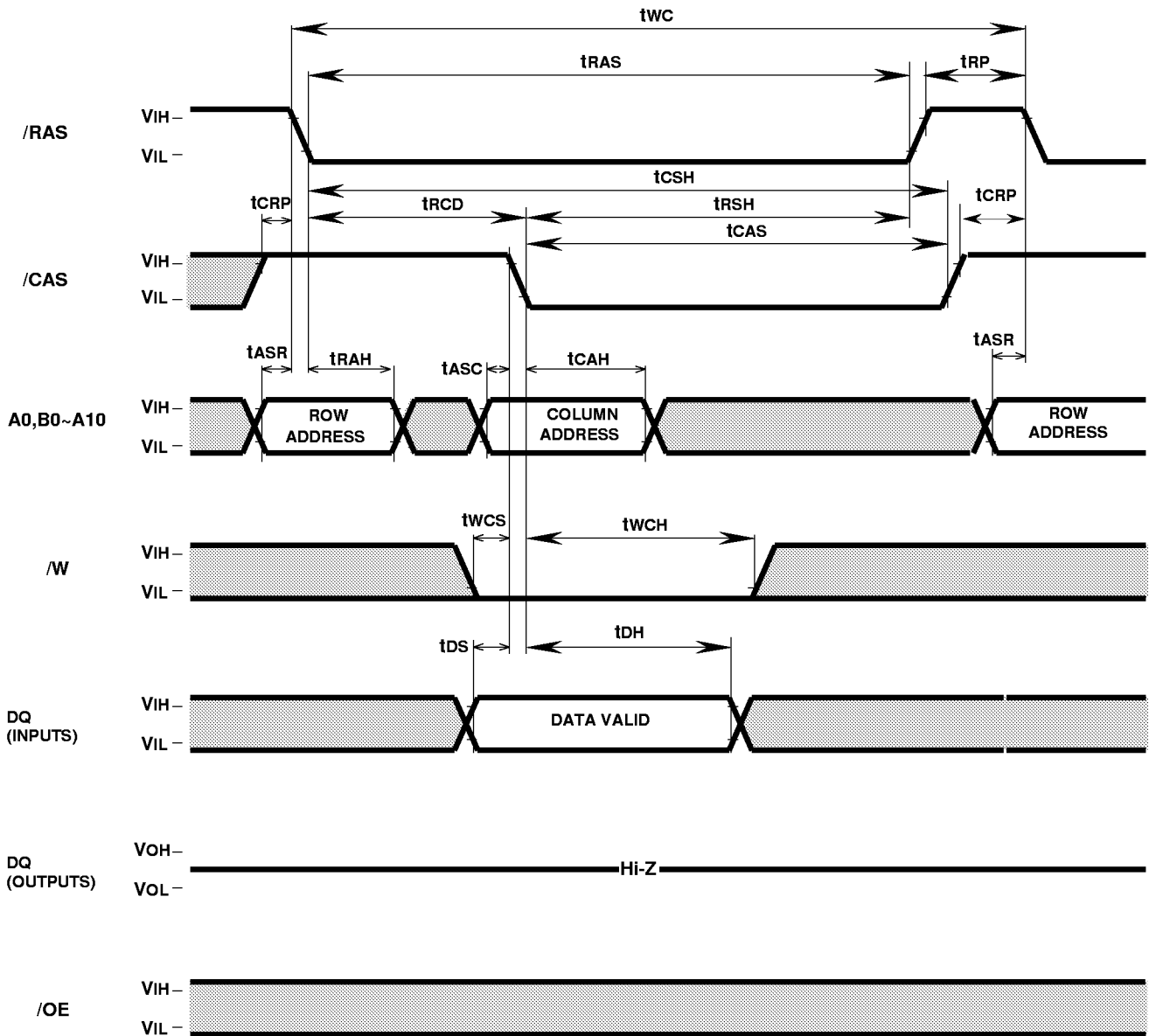

Read-Write, Read-Modify-Write Cycle

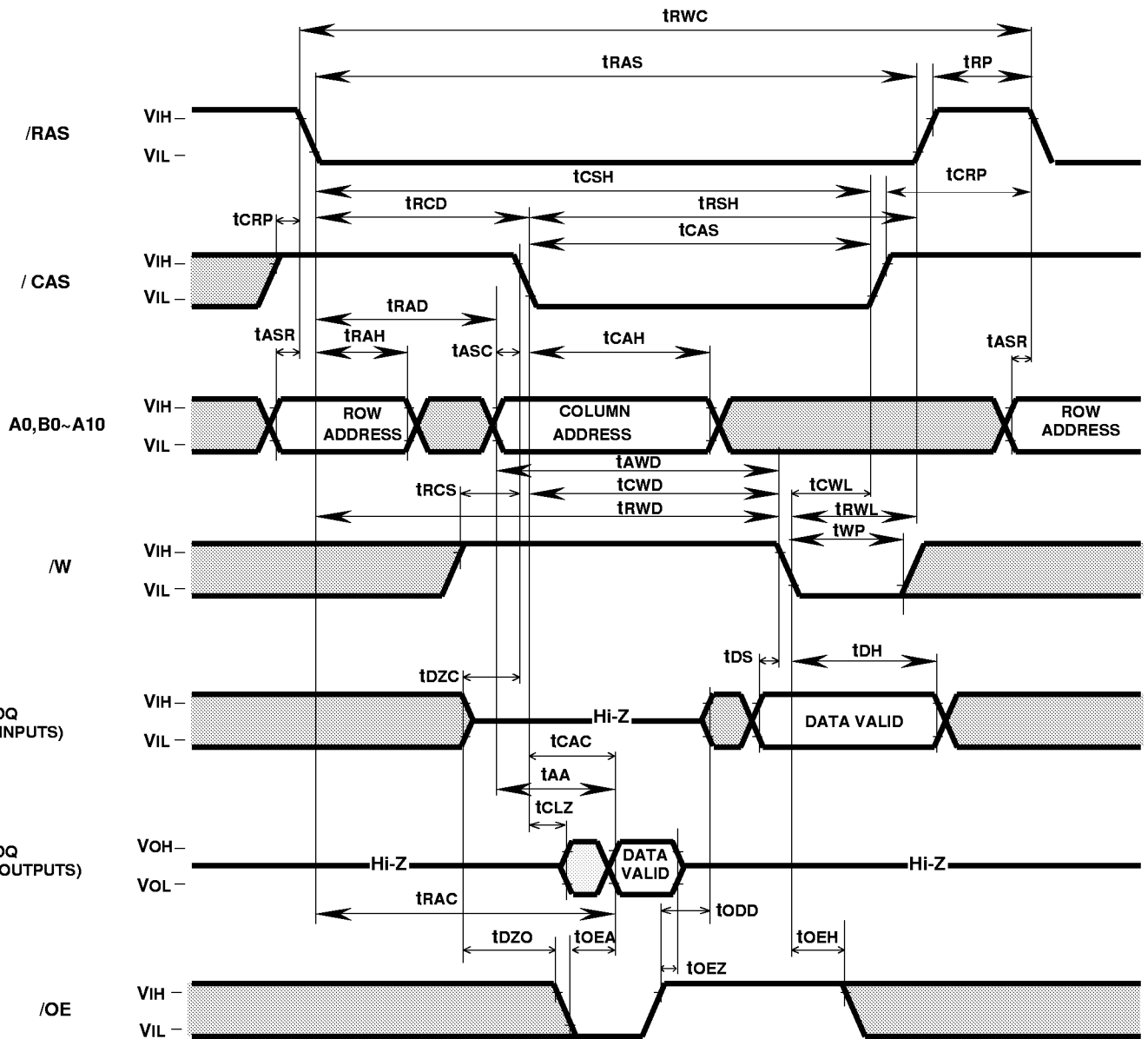

Hyper Page Mode Read Cycle

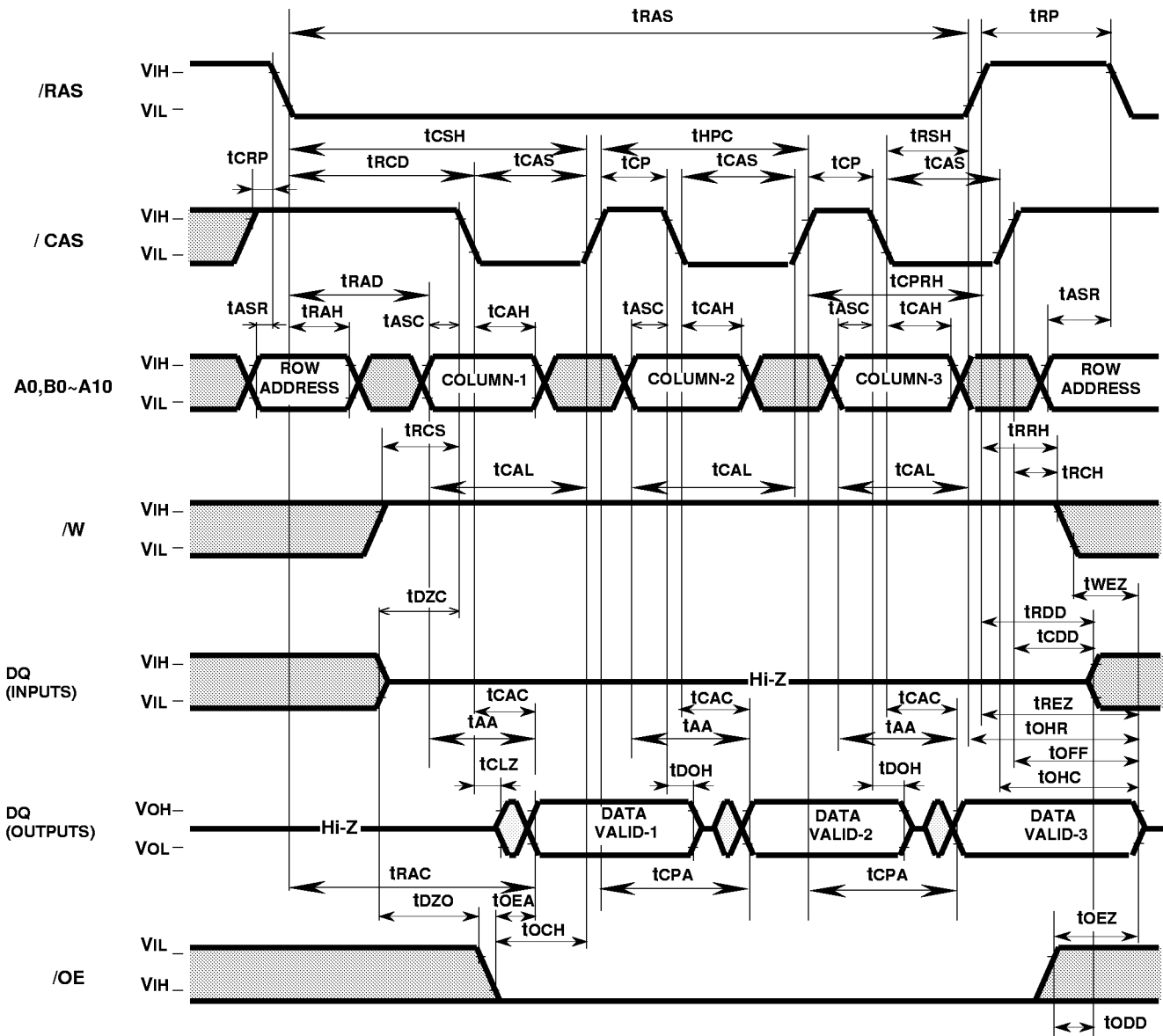

Hyper Page Mode Early Write Cycle

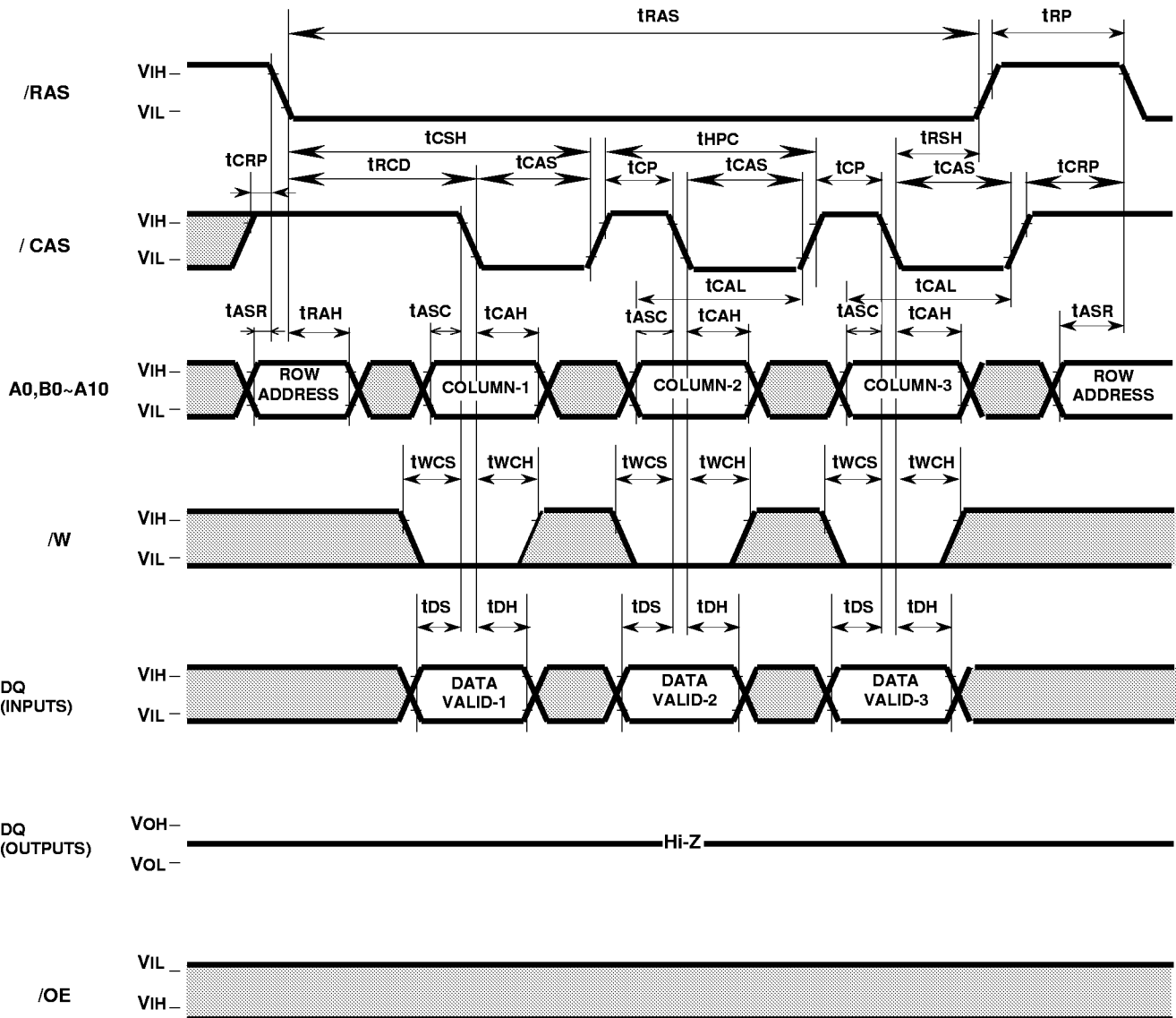

Hyper Page Mode Mix Cycle (1)

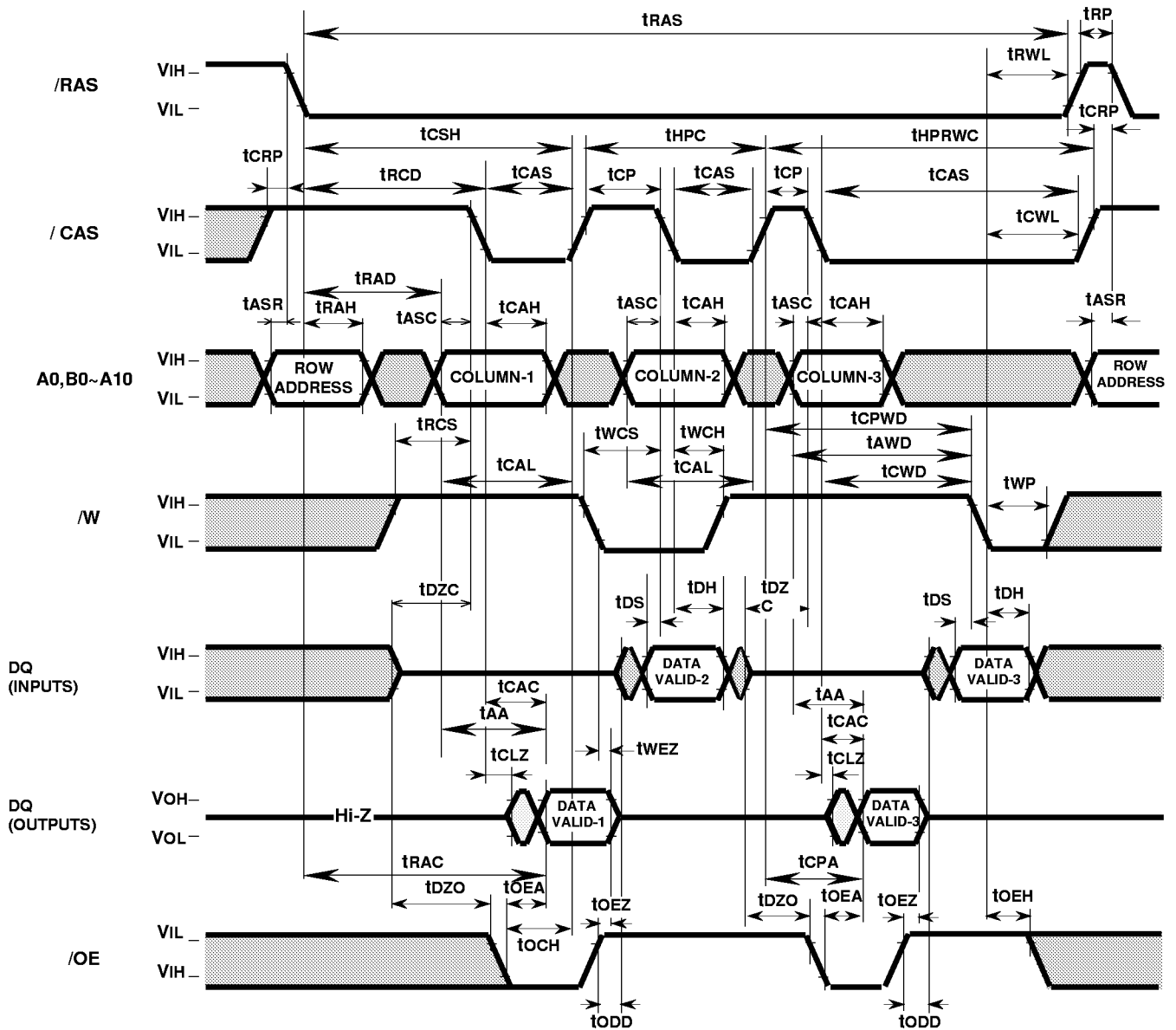

Hyper Page Mode Mix Cycle (2)

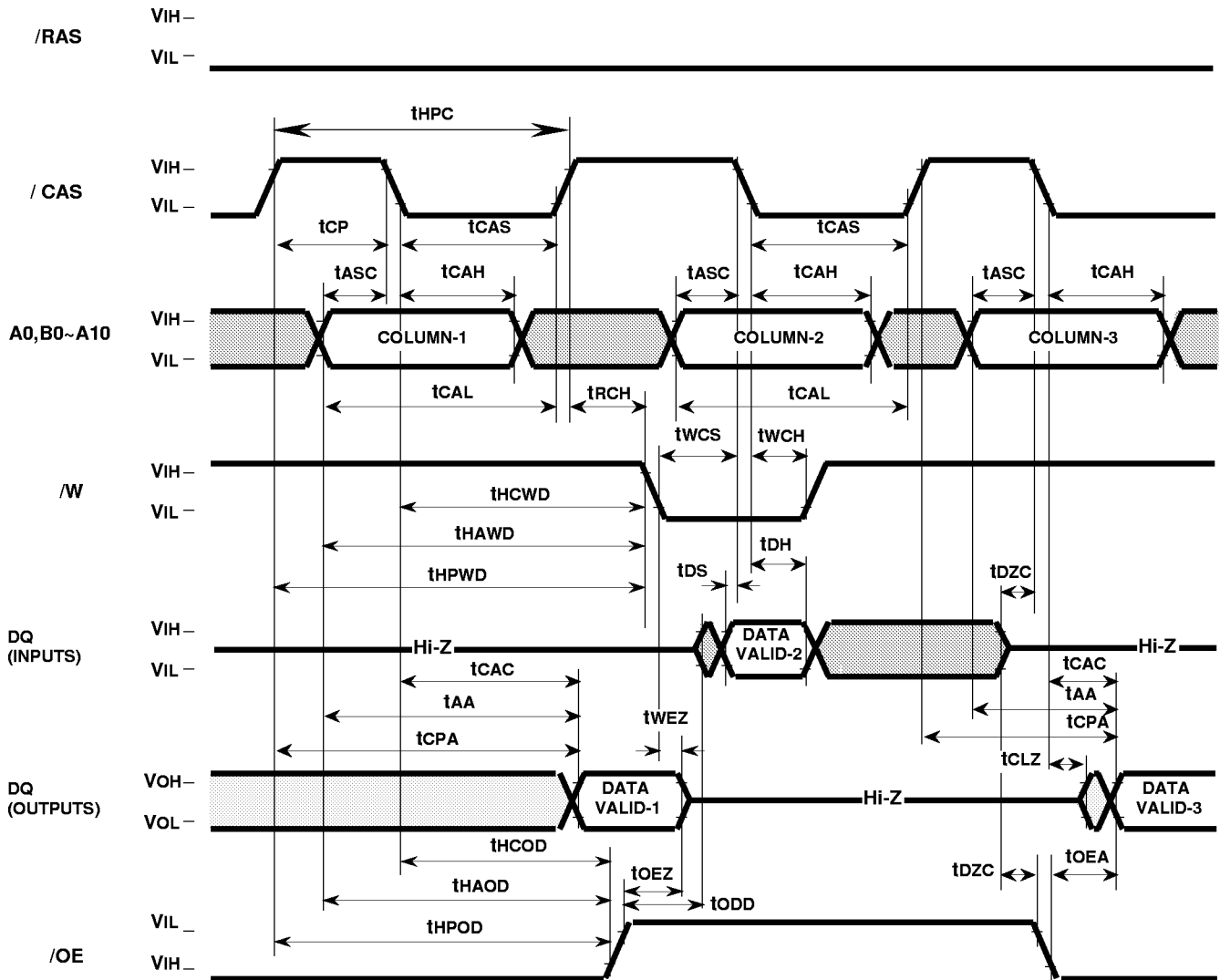

Hyper Page Mode Read Cycle (Hi-Z control by \overline{OE})

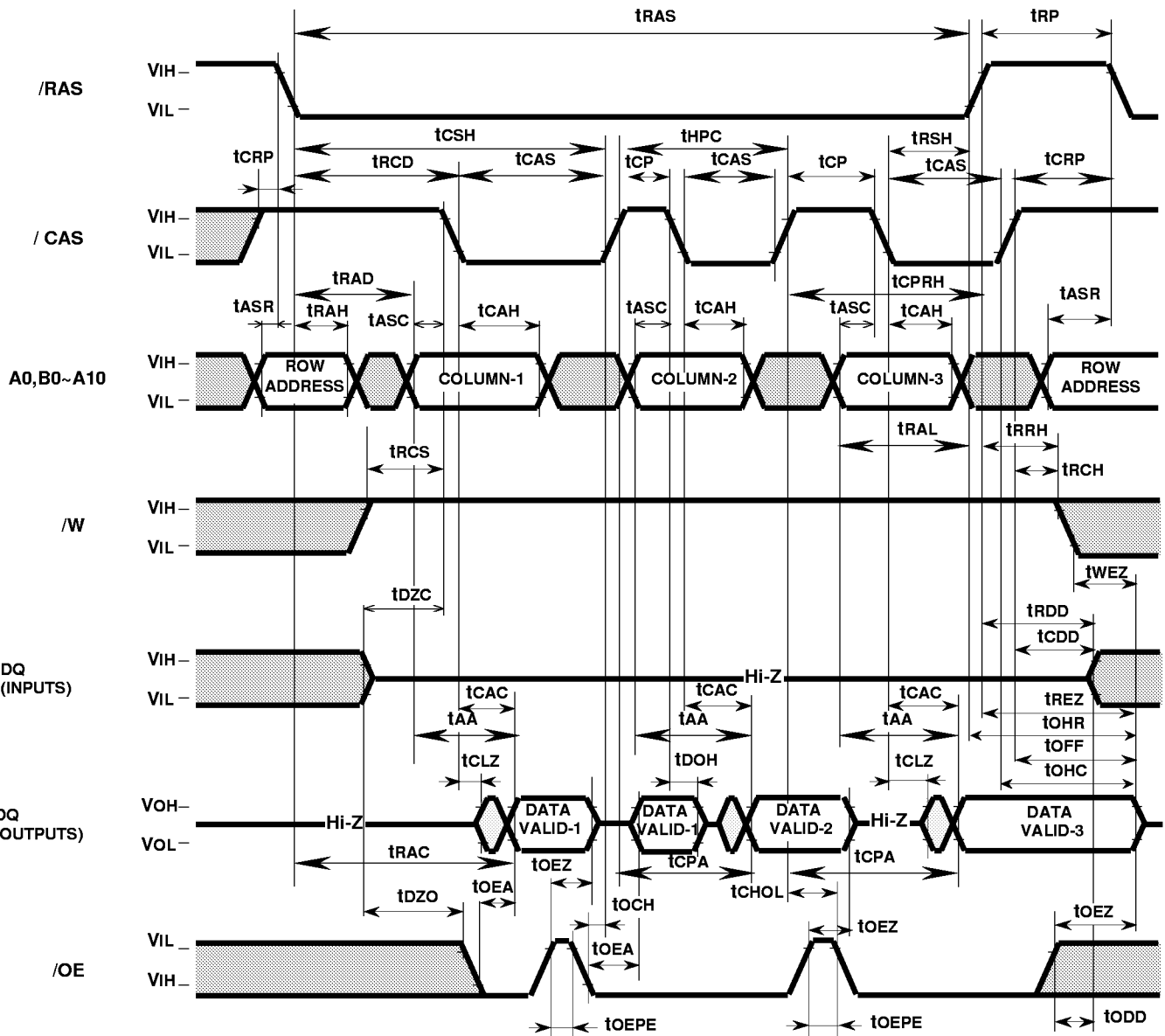

Hyper Page Mode Read Cycle (Hi-Z control by \overline{W})

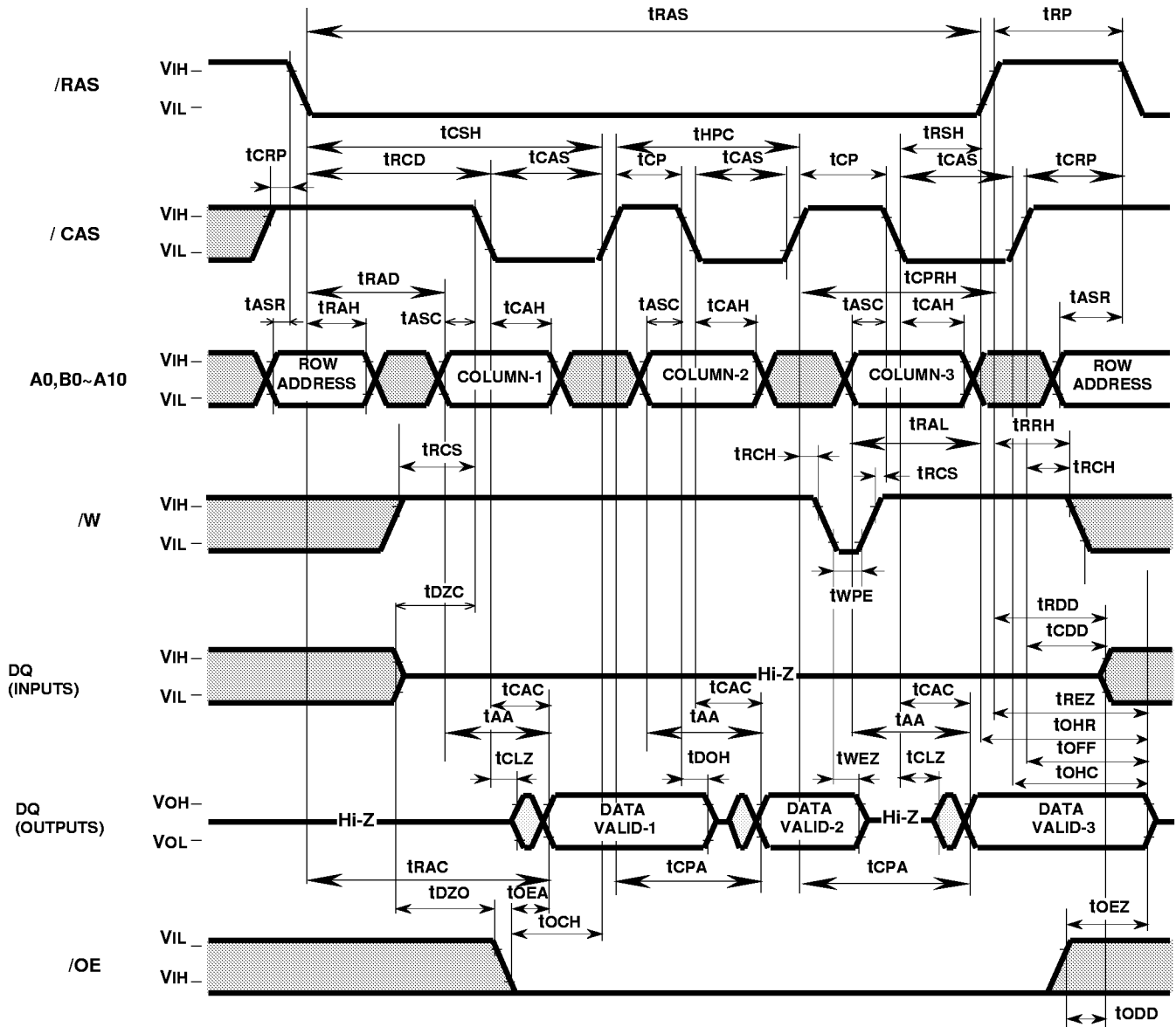

RAS-only Refresh Cycle

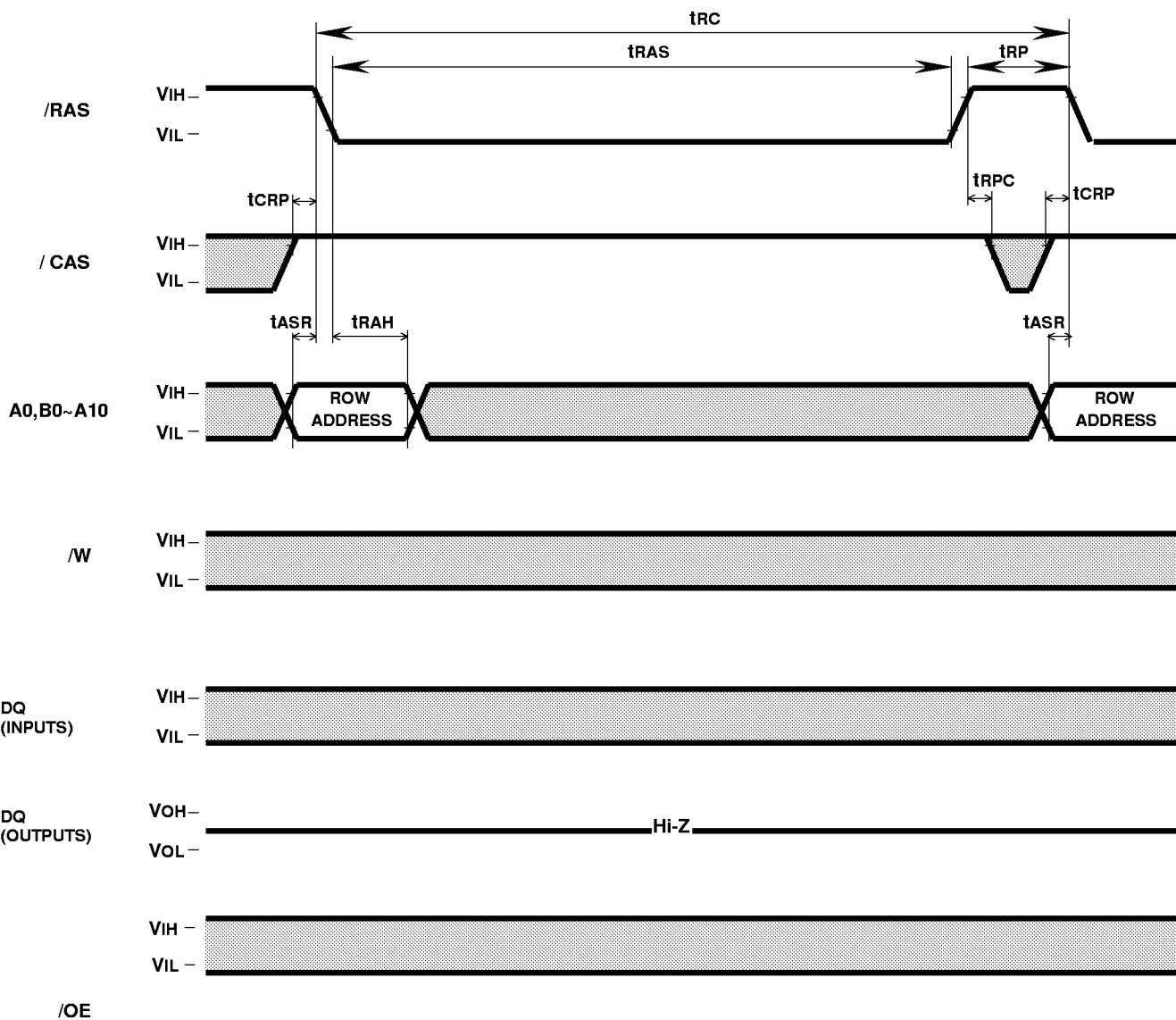

Hidden Refresh Cycle (Read) (Note 31)

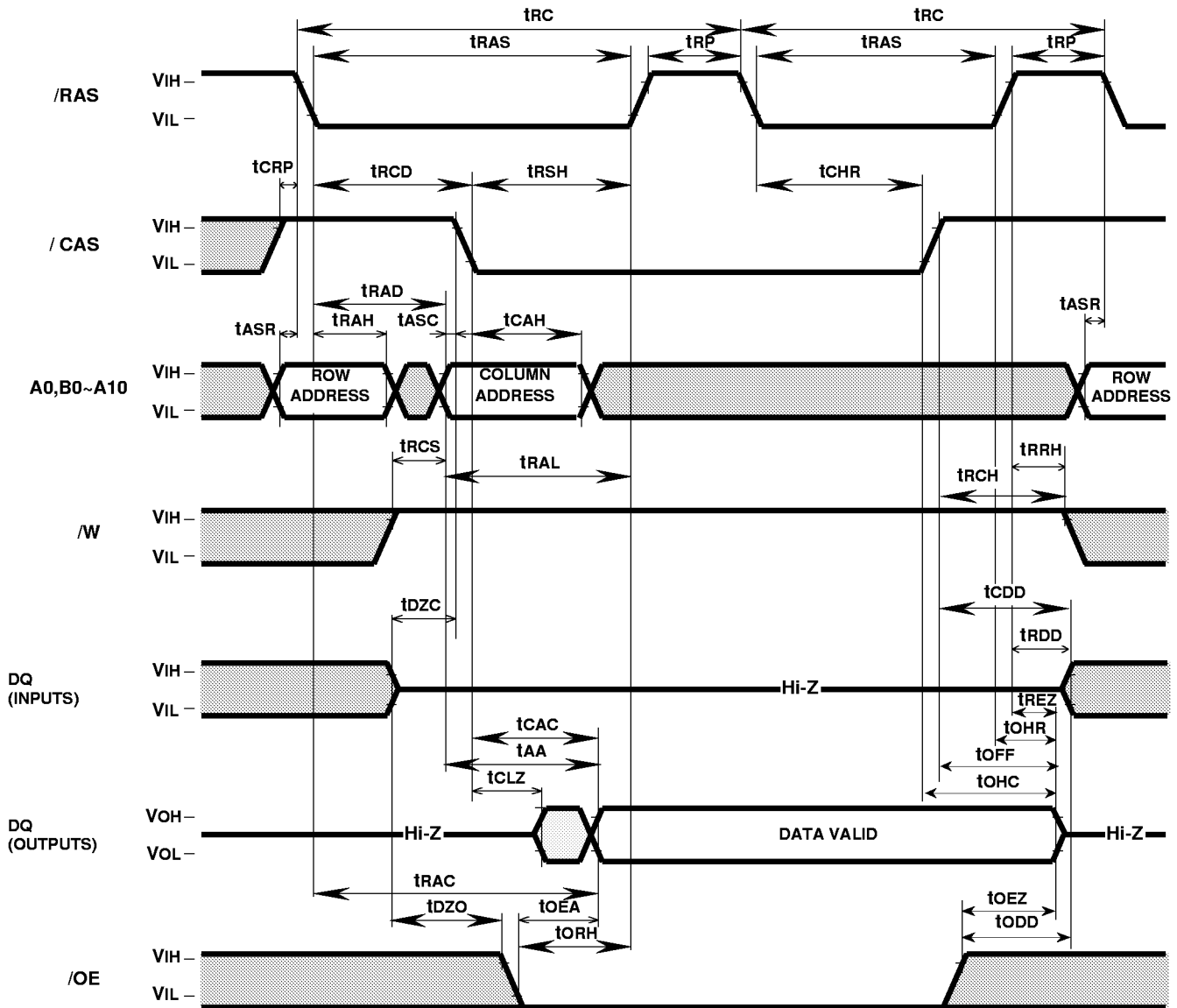

Note 31: Early write, delayed write, read write or read modify write cycle is applicable instead of read cycle. Timing requirements and output state are the same as that of each cycle shown above.

Self Refresh Cycle*

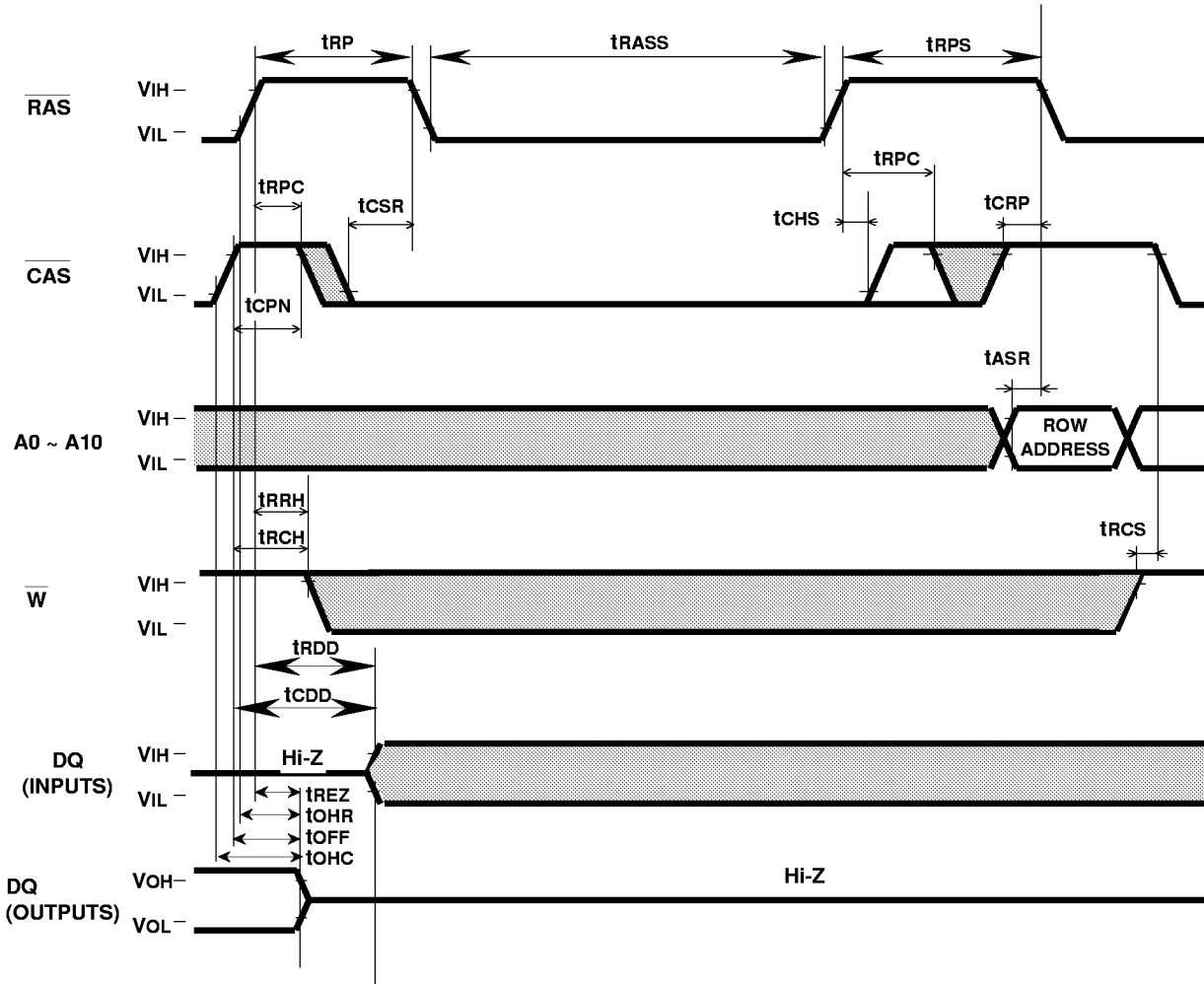

Unit:mm

Package outline

