

# TLP523, -2, -4

(TLP523)  
 PROGRAMMABLE CONTROLLERS  
 DC-OUTPUT MODULE  
 SOLID STATE RELAY

The TOSHIBA TLP523, -2 and -4 consists of a gallium arsenide infrared emitting diode coupled with a silicon, darlington connected, phototransistor which has an integral base-emitter resistor to optimize switching speed and elevated temperature characteristics. The TLP523-2 offers two isolated channels in a eight lead plastic DIP package, while the TLP523-4 provide four isolated channels per package.

- Current Transfer Ratio : 500% (Min.) ( $I_F = 1\text{mA}$ )
- Isolation Voltage : 2500Vrms (Min.)
- Collector-Emitter Voltage : 55V (Min.)
- Leakage Current :  $10\mu\text{A}$  (Max.) ( $T_a = 85^\circ\text{C}$ )
- UL Recognized : UL1577, File No. E67349

PIN CONFIGURATIONS (TOP VIEW)

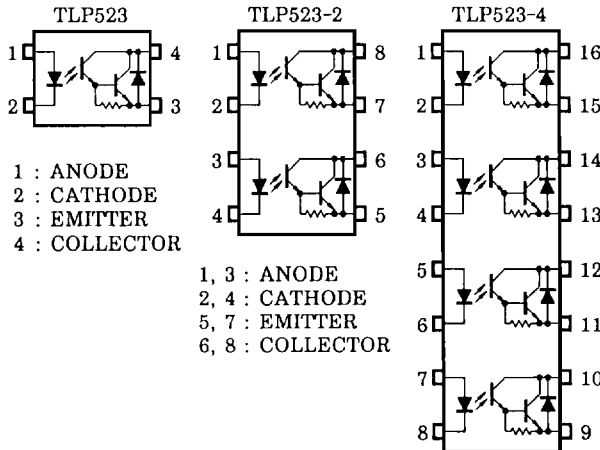

1 : ANODE  
 2 : CATHODE  
 3 : EMITTER  
 4 : COLLECTOR

1, 3 : ANODE  
 2, 4 : CATHODE  
 5, 7 : EMITTER  
 6, 8 : COLLECTOR

1, 3, 5, 7 : ANODE  
 2, 4, 6, 8 : CATHODE  
 9, 11, 13, 15 : EMITTER  
 10, 12, 14, 16 : COLLECTOR

Unit in mm

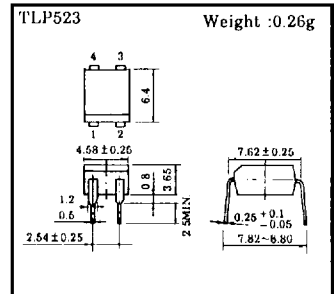

JEDEC —

EIAJ —

TOSHIBA 11-5B1

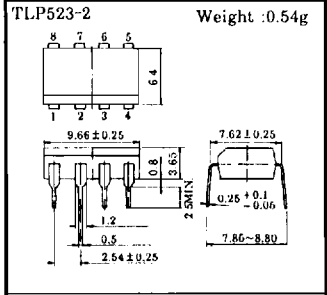

JEDEC —

EIAJ —

TOSHIBA 11-10C1

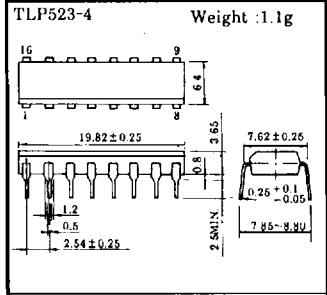

JEDEC —

EIAJ —

TOSHIBA 11-20A1

# TLP523, -2, -4

(TLP523)

MAXIMUM RATINGS (Ta = 25°C)

CHARACTERISTIC		SYMBOL	RATING		UNIT
			TLP523	TLP523-2 TLP523-4	
LED	Forward Current	I <sub>F</sub>	60	50	mA
	Forward Current Derating	ΔI <sub>F</sub> /°C	-0.7 (Ta ≥ 39°C)	-0.5 (Ta ≥ 25°C)	mA / °C
	Pulse Forward Current	I <sub>FP</sub>	1 (100μs pulse, 100pps)		A
	Reverse Voltage	V <sub>R</sub>	5		V
DETECTOR	Collector-Emitter Voltage	V <sub>CEO</sub>	55		V
	Emitter-Collector Voltage	V <sub>ECO</sub>	0.3		V
	Collector Current	I <sub>C</sub>	150		mA
	Collector Power Dissipation (1 Circuit)	P <sub>C</sub>	150	100	mW
	Collector Power Dissipation Derating (1 Circuit (Ta ≥ 25°C))	ΔP <sub>C</sub> /°C	-1.5	-1.0	mW / °C
	Operating Temperature Range	T <sub>opr</sub>	-55~100		°C
	Storage Temperature Range	T <sub>stg</sub>	-55~150		°C
Lead Solder Temperature (10 s)	T <sub>sol</sub>	260		°C	
Total Power Dissipation	P <sub>T</sub>	250	150	mW	
Total Power Dissipation Derating (Ta ≥ 25°C)	ΔP <sub>T</sub> /°C	-2.5	-1.5	mW / °C	
Isolation Voltage (Note 1)	BV <sub>S</sub>	2500 (AC, 1 min., RH ≤ 60%)		V <sub>rms</sub>	

Note 1 : Device considered a two terminal device : LED side pins shorted together and DETECTOR side pins shorted together.

## RECOMMENDED OPERATING CONDITIONS

CHARACTERISTIC	SYMBOL	MIN.	TYP.	MAX.	UNIT
Supply Voltage	V <sub>CC</sub>	—	5	24	V
Forward Current	I <sub>F</sub>	—	16	20	mA
Operating Temperature Range	T <sub>opr</sub>	-25	—	85	°C

(TLP523)

ELECTRICAL CHARACTERISTICS (Ta = 25°C)

CHARACTERISTIC		SYMBOL	TEST CONDITION	MIN.	TYP.	MAX.	UNIT
LED	Forward Voltage	$V_F$	$I_F = 10\text{mA}$	1.0	1.15	1.3	V
	Reverse Current	$I_R$	$V_R = 5\text{V}$	—	—	10	$\mu\text{A}$
	Capacitance	$C_T$	$V = 0, f = 1\text{MHz}$	—	30	—	pF
DETECTOR	Collector-Emitter Breakdown Voltage	$V_{(BR)CEO}$	$I_C = 1\text{mA}$	55	—	—	V
	Collector Dark Current	$I_{CEO}$	$V_{CE} = 24\text{V}$	—	10	200	nA
			$V_{CE} = 24\text{V}, T_a = 85^\circ\text{C}$	—	0.5	10	$\mu\text{A}$
Capacitance Collector to Emitter	$C_{CE}$	$V = 0, f = 1\text{MHz}$	—	10	—	pF	
COUPLED	Current Transfer Ratio	$I_C / I_F$	$I_F = 1\text{mA}, V_{CE} = 1\text{V}$	500	2000	—	%
	Collector-Emitter Saturation Voltage	$V_{CE(sat)}$	$I_C = 50\text{mA}, I_F = 10\text{mA}$	—	—	1	V
	Capacitance Input to Output	$C_S$	$V_S = 0, f = 1\text{MHz}$	—	0.8	—	pF
	Isolation Resistance	$R_S$	$V_S = 500\text{V}$	$5 \times 10^{10}$	$10^{14}$	—	$\Omega$

SWITCHING CHARACTERISTICS (Ta = 25°C)

CHARACTERISTIC	SYMBOL	TEST CONDITION	MIN.	TYP.	MAX.	UNIT
Turn-on Time	$t_{ON}$	$V_{CC} = 10\text{V}, R_L = 180\Omega$ $I_F = 16\text{mA}$	—	3	—	$\mu\text{s}$
Turn-off Time	$t_{OFF}$		—	80	—	$\mu\text{s}$

SWITCHING TIME TEST CIRCUIT

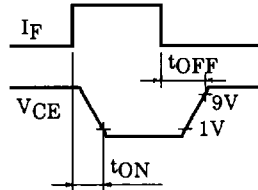
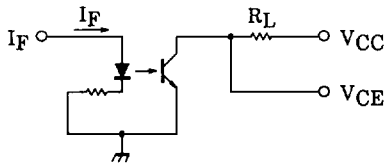

# TLP523, -2, -4

(TLP523)

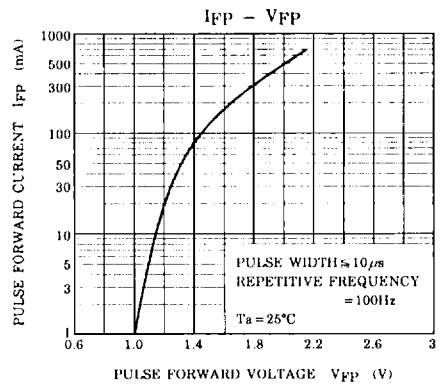
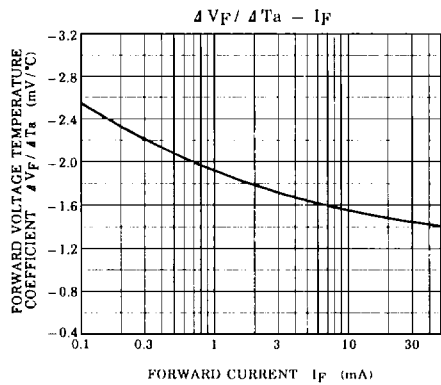
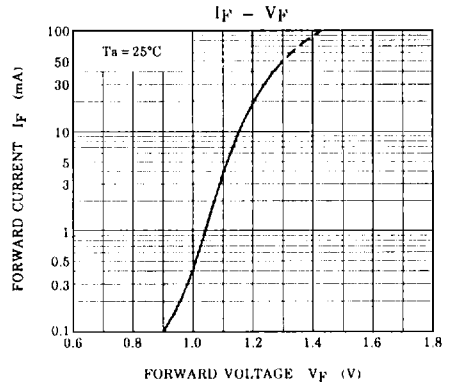
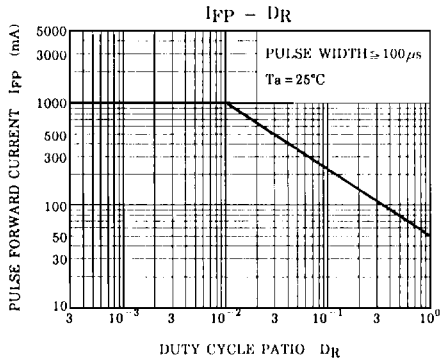
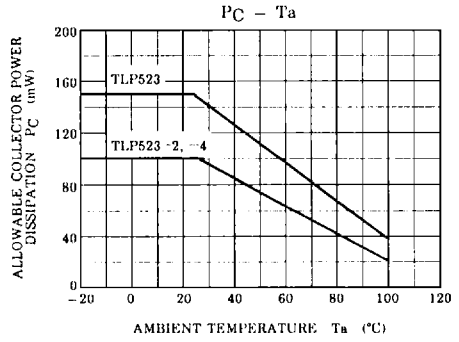
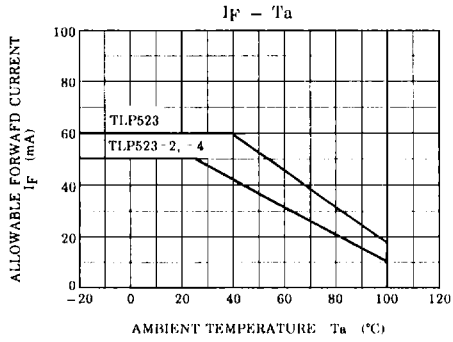

(TLP523)

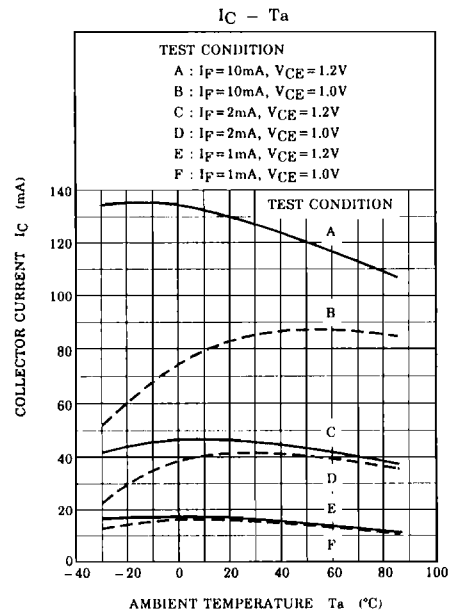
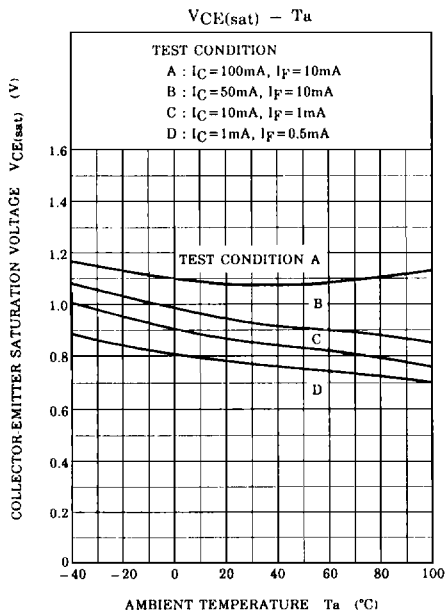
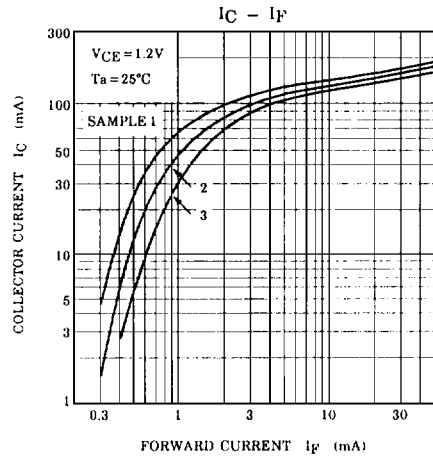
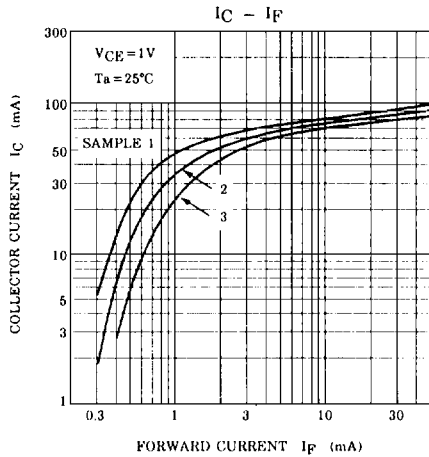

# TLP523, -2, -4

(TLP523)

