

300APTR-CR

TNC Male Right Angle for CNT-300 braided cable

OBSOLETE

Replaced By:

300BPTR-C

TNC Male Right Angle for CNT-300 braided cable

Product Classification

Product Type	Braided cable connector
Product Brand	CNT®

General Specifications

Body Style	Right angle
Inner Contact Attachment Method	Solder
Inner Contact Plating	Silver
Interface	TNC Male
Outer Contact Attachment Method	Crimp
Outer Contact Plating	Trimetal
Pressurizable	No

Dimensions

Height	27.31 mm 1.075 in
Width	16.5 mm 0.65 in
Length	33.12 mm 1.304 in
Nominal Size	0.300 in

Outline Drawing

300APTR-CR

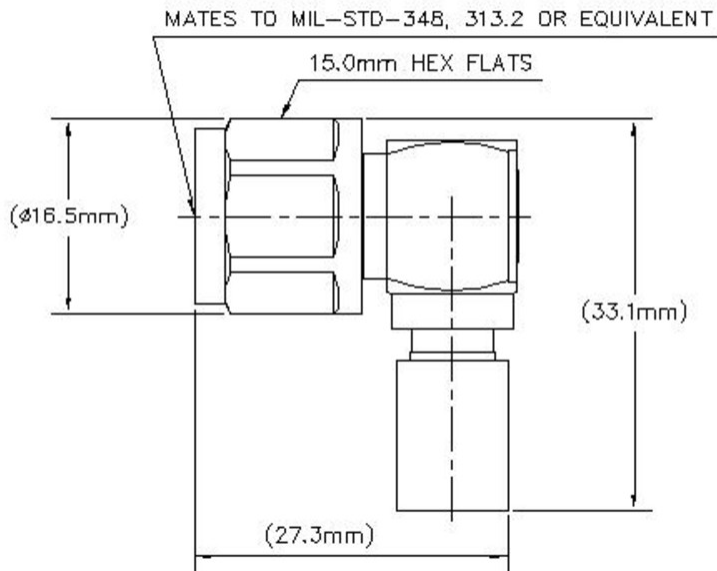

Electrical Specifications

Insertion Loss, typical	0.05 dB
Average Power at Frequency	360.0 W @ 900 MHz
Cable Impedance	50 ohm
Connector Impedance	50 ohm
dc Test Voltage	1500 V
Inner Contact Resistance, maximum	1.5 mOhm
Insulation Resistance, minimum	5000 MOhm
Operating Frequency Band	0 – 6000 MHz
Outer Contact Resistance, maximum	0.4 mOhm
Peak Power, maximum	5 kW
RF Operating Voltage, maximum (vrms)	500 V

VSWR/Return Loss

Frequency Band	VSWR	Return Loss (dB)
0–3000 MHz	1.124	24.68

Mechanical Specifications

Connector Retention Tensile Force	220 N 49.458 lbf
Connector Retention Torque	0.45 N-m 3.983 in lb

300APTR-CR

Coupling Nut Proof Torque	1.7 N-m 15.046 in lb
Coupling Nut Proof Torque Method	IEC 61169-17:9.3.6
Coupling Nut Retention Force	445 N 100.04 lbf
Coupling Nut Retention Force Method	IEC 61169-17:9.3.11
Insertion Force	15 N 3.372 lbf
Insertion Force Method	IEC 61169-17:9.3.5
Interface Durability	500 cycles
Interface Durability Method	IEC 61169-17:17
Mechanical Shock Test Method	IEC 60068-2-27

Environmental Specifications

Operating Temperature	-40 °C to +85 °C (-40 °F to +185 °F)
Storage Temperature	-65 °C to +125 °C (-85 °F to +257 °F)
Attenuation, Ambient Temperature	20 °C 68 °F
Average Power, Ambient Temperature	40 °C 104 °F
Average Power, Inner Conductor Temperature	100 °C 212 °F
Climatic Sequence Test Method	IEC 60068-1
Corrosion Test Method	IEC 60068-2-11
Damp Heat Steady State Test Method	IEC 60068-2-3
Thermal Shock Test Method	IEC 60068-2-14
Vibration Test Method	IEC 60068-2-6
Water Jetting Test Mating	Mated
Water Jetting Test Method	IEC 60529:2001, IP65

Packaging and Weights

Weight, net	31.23 g 0.069 lb
--------------------	--------------------

Regulatory Compliance/Certifications

Agency	Classification
CHINA-ROHS	Below maximum concentration value
ISO 9001:2015	Designed, manufactured and/or distributed under this quality management system
REACH-SVHC	Compliant as per SVHC revision on www.commscope.com/ProductCompliance
ROHS	Compliant

300APTR-CR



* Footnotes

Insertion Loss, typical 0.05v~freq (GHz) (not applicable for elliptical waveguide)